

Angular Air Gripper

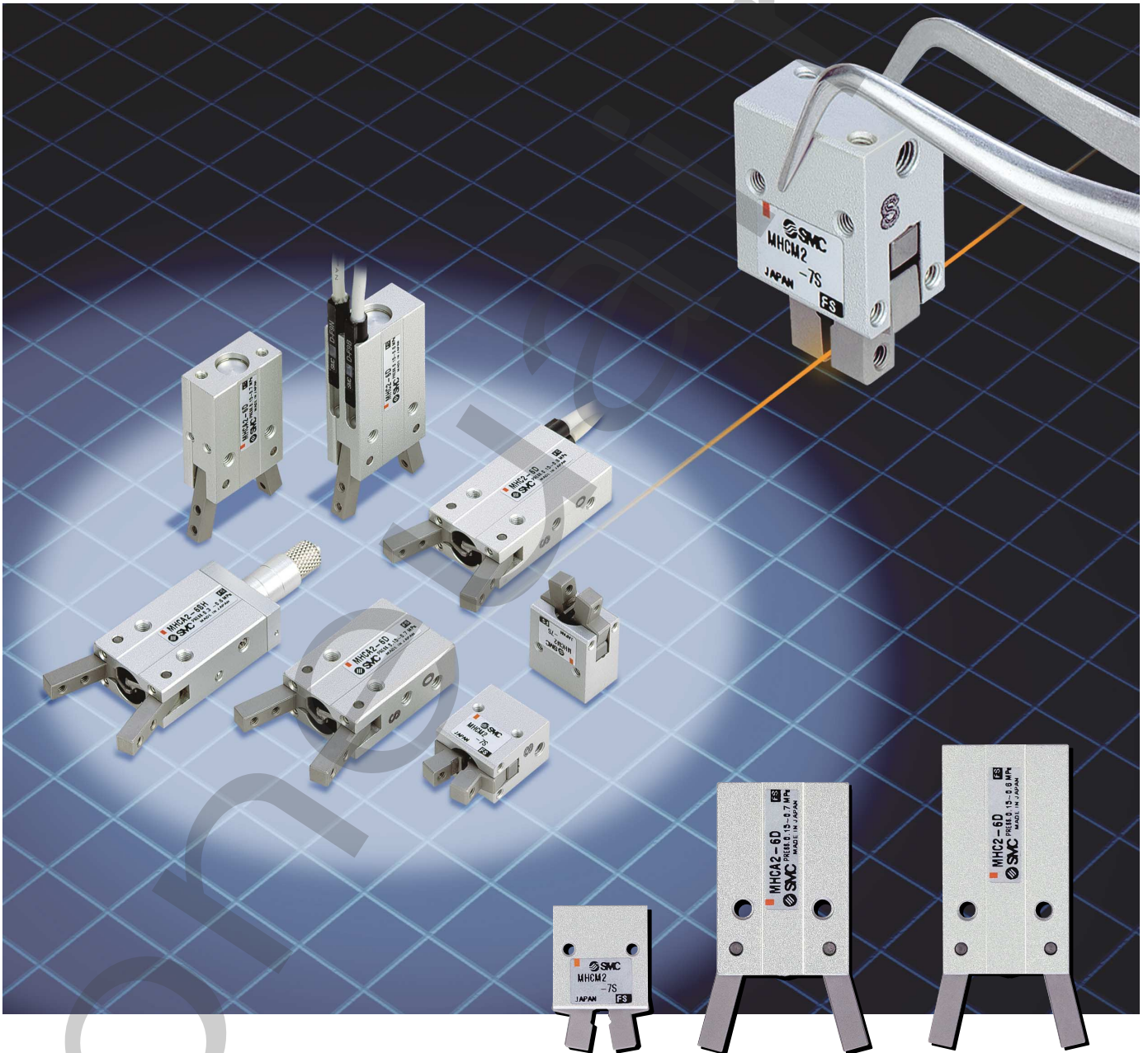

- Angular style air gripper **Series MHC** now also available in $\phi 6$ size.
- **Series MHCM2** now available for further miniaturisation.

Series **MHC2/MHCA2/MHCM2**

Angular air gripper

Series MHC2/MHCA2/MHCM2

MHC2-6

Auto switch is attachable.

48mm x 20mm x 10mm 22g

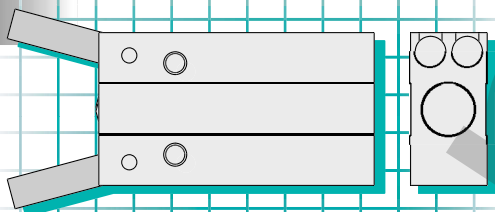

(Full size)

MHCA2-6

Short body.

41mm x 20mm x 10mm 19g

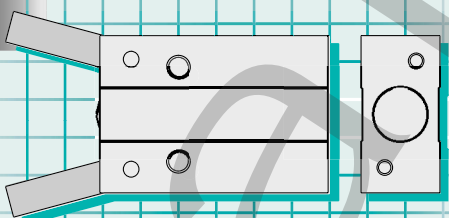

(Full size)

MHCM2-7S

Smallest size and lightest weight in MHC series.

23mm x 15mm x 10mm 9.5g

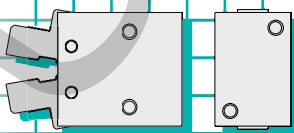

(Full size)

Body option (Only for MHCA2-6)

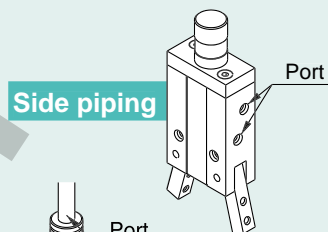

Side piping

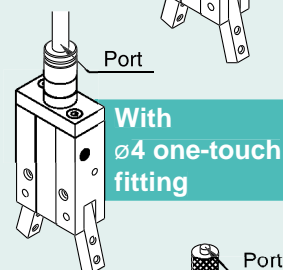

With
ø4 one-touch
fitting

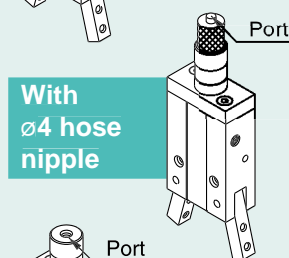

With
ø4 hose
nipple

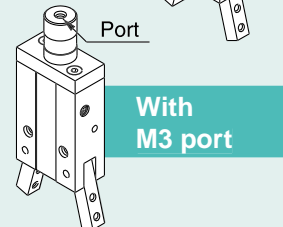

With
M3 port

Variations



P5



P5



P13

Model	MHC2-6	MHCA2-6	MHCM2-7S
Cylinder bore	ø6	ø6	ø7
Action	Double acting Single acting (normally open)		Single acting (normally open)
Opening / Closing angle (both sides)	30° to -10°		20 to -7
Holding moment (at 0.5 MPa)	0.038N·m (double acting) 0.024N·m (single acting)		0.017N·m
Repeat ability	±0.02mm		
Maximum operating frequency	180c.p.m		
Weight	22g (Note)	19g	9.5g
Auto switch	Solid state switch (2-wire, 3-wire)	—	—
Body option	—	End boss type	—

Note) Not including auto switch weight.

Series MHC2/MHCA2/MHCM2 Model Selection

Model Selection

Selection procedure

Step 1 Confirm gripping force

Step 2 Confirmation of inertial moment of attachment

Step 1 Confirmation of gripping force

Confirmation of conditions

Calculation of required gripping force

Model selection from gripping force graph

Example Work piece weight: **0.01kg**

Gripping method: External gripping

Model selection criteria with respect to work piece weight

- Although differences will exist depending on factors such as shape and the coefficient of friction between the attachments and work pieces, select a model which will provide a gripping force 10 to 20 times (Note 1) the weight of the work piece.
- (Note 1) Refer to the model selection illustration for more information.
- Furthermore, in cases with high acceleration or impact, etc., it is necessary to allow an even greater margin of safety.

Example: When it is desired to set the gripping force at 10 times or more the work piece weight.
 Required gripping force = $0.01 \text{ kg} \times 10 \times 9.8 \text{ m/s}^2$
 = Approx. 0.98N or more

MHC2-6D/MHCA2-6D

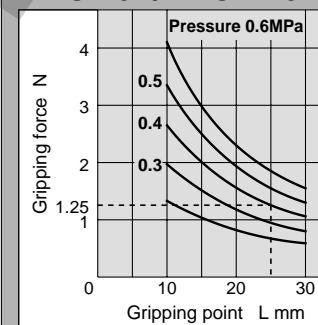

Length of gripping point: **25mm**

Operating pressure: **0.4MPa**

- Selecting the MHC2-6D. The gripping force of 1.25N is obtained from the intersection point of gripping point distance L = 25mm and pressure of 0.4MPa.
- The gripping force is 12.7 times greater than the work piece weight, and therefore satisfies a gripping force setting value of 10 times or more.

Model selection illustration

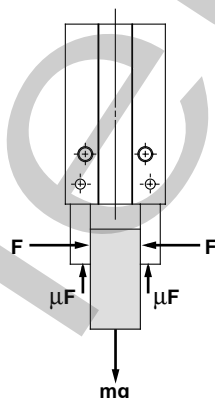

Gripping force at least 10 to 20 times the work piece weight

The "10 to 20 times or more of the work piece weight" recommended by P/A is calculated with the safety margin of $a = 4$, which allows for impacts that occur during normal transportation, etc.

When $\mu = 0.2$	When $\mu = 0.1$
$F = \frac{mg}{2 \times 0.2} \times 4$	$F = \frac{mg}{2 \times 0.1} \times 4$
$= 10 \times mg$	$= 20 \times mg$

10 x work piece weight

20 x work piece weight

(Note) · Even in cases where the coefficient of friction is greater than $\mu = 0.2$, for safety reasons, P/A recommends selecting a gripping force which is at least 10 to 20 times the work piece weight.
 · It is necessary to allow a greater safety margin for high accelerations and strong impacts, etc.

When gripping a work piece as in the figure to the left and with the following definitions,

- F:** Gripping force (N)
- μ : Coefficient of friction between attachments and work piece
- m:** Work piece mass (kg)
- g:** Gravitational acceleration (= 9.8 m/s^2)
- mg:** Work piece weight (N)

the conditions under which the work piece will not drop are

$$2 \times \mu F > mg$$

↑
Number of fingers

and therefore,

$$F > \frac{mg}{2 \times \mu}$$

With "a" as the safety margin, F is determined as follows:

$$F = \frac{mg}{2 \times \mu} \times a$$

Step 1 Effective gripping force: Series MHC□2 External gripping force

●Expressing the effective gripping force

The effective gripping force shown in the graphs to the right is expressed as F, which is the thrust of one finger when both fingers and attachments are in full contact with the work piece as shown in the figure below.

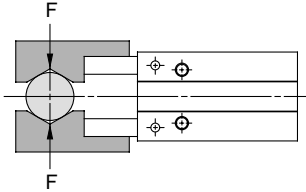

External gripping

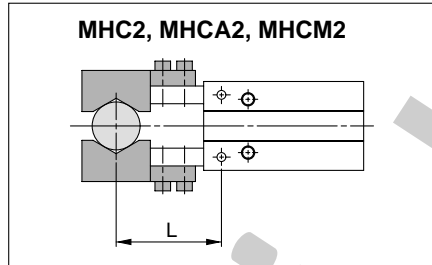

MHC2-6D/MHCA2-6D

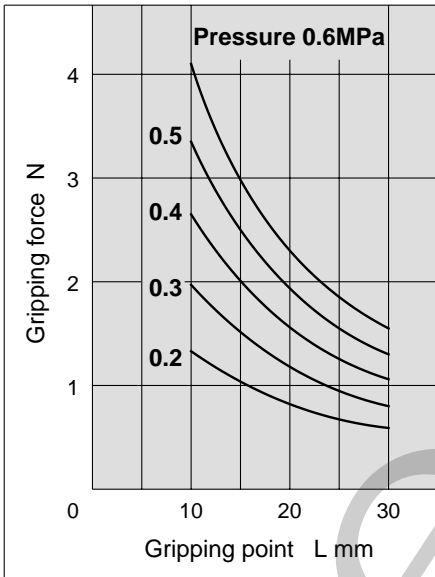

MHC2-6S/MHCA2-6S

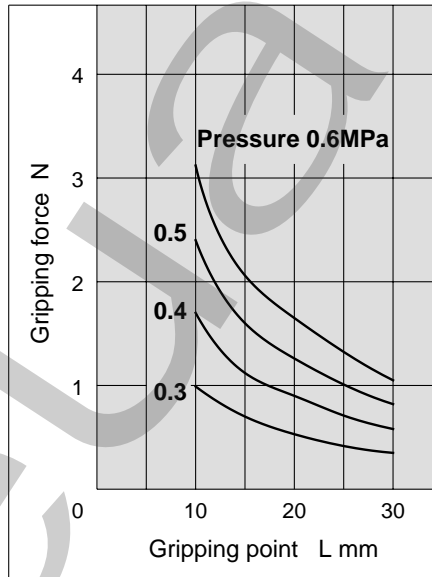

MHCM2-7S

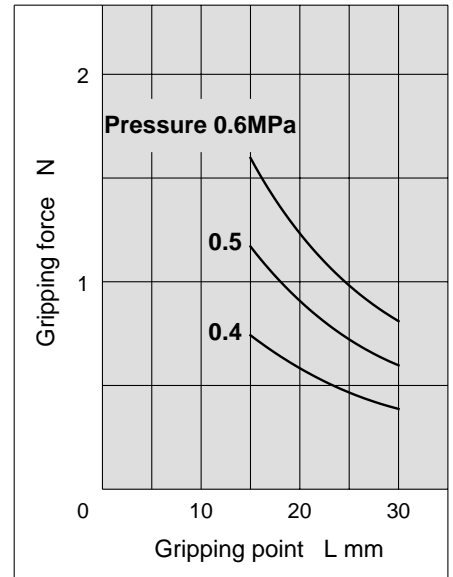

Series MHC2/MHCA2/MHCM2

Step 2 Confirmation of inertial moment of attachment

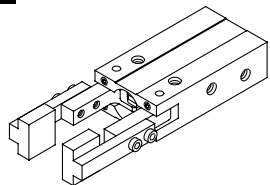

Confirm the inertial moment of one of the two attachments.
For example, in calculating the inertial moment of an attachment in the picture on the right, divide it into 2 rectangular parallelepipeds, A part and B part.

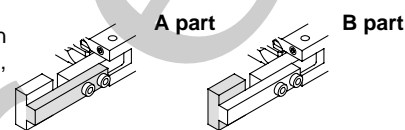

Procedure	Formula	Example						
<p>1. Calculate the operating conditions and attachment dimensions.</p>	<p>A part</p> <p>B part</p>	<p>Operating equipment: MHC2-6D a = 20 (mm) b = 3 (mm) c = 4 (mm) d = 4 (mm) e = 5 (mm) f = 6 (mm)</p>						
<p>2. Calculate the inertial moment of the attachment.</p>	<p>A part</p> <p>Weight calculation $m_1 = a \times b \times c \times \text{Relative density}$</p> <p>Inertial moment around Z1 axis $I_{z1} = \{m_1 (a^2 + b^2) / 12\} \times 10^{-6} *$</p> <p>Inertial moment around Z axis $I_A = I_{z1} + m_1 r_1^2 \times 10^{-6} *$</p> <p>B part</p> <p>Weight calculation $m_2 = d \times e \times f \times \text{Relative density}$</p> <p>Inertial moment around Z2 axis $I_{z2} = \{m_2 (d^2 + e^2) / 12\} \times 10^{-6} *$</p> <p>Inertial moment around Z axis $I_B = I_{z2} \times m_2 r_2^2 \times 10^{-6} *$</p> <p>Thus, the total inertial moment is $I = I_A \times B$ (*: Unit conversion constant)</p>	<p>Assuming the attachment material is aluminium alloy (relative density=2.7), $r_1 = 16.4$ (mm).</p> <p>$m_1 = 20 \times 3 \times 4 \times 2.7 \times 10^{-6}$ $= 6.48 \times 10^{-4}$ (kg)</p> <p>$I_{z1} = \{6.48 \times 10^{-4} \times (20^2 + 3^2) / 12\} \times 10^{-6}$ $= 2.21 \times 10^{-8}$ (kg·m²)</p> <p>$I_A = 2.21 \times 10^{-8} + 6.48 \times 10^{-4} \times 16.4^2 \times 10^{-6}$ $= 0.20 \times 10^{-6}$ (kg·m²)</p> <p>$r_2 = 23.5$(mm)</p> <p>$m_2 = 4 \times 5 + 6 \times 2.7 \times 10^{-6}$ $= 3.24 \times 10^{-4}$ (kg)</p> <p>$I_{z2} = \{3.24 \times 10^{-4} \times (4^2 + 5^2) / 12\} \times 10^{-6}$ $= 1.11 \times 10^{-9}$ (kg·m²)</p> <p>$I_B = 1.11 \times 10^{-9} + 3.24 \times 10^{-4} \times 23.5^2 \times 10^{-6}$ $= 0.18 \times 10^{-6}$ (kg·m²)</p> <p>$I = 0.20 \times 10^{-6} + 0.18 \times 10^{-6}$ $= 0.38 \times 10^{-6}$ (kg·m²)</p>						
<p>3. Confirm from the table that the inertial moment of one attachment is within the allowable range.</p>	<p>MHC2-6D/MHCA2-6D</p> <table border="1"> <tr> <td>Finger opening and closing speed</td> <td>Allowable inertial moment of attachment</td> </tr> <tr> <td>Without speed controller</td> <td>0.5×10^{-6} Kg·m²</td> </tr> <tr> <td>With speed controller 3/4 to 1 and 1/2 reverse rotation from fully close state</td> <td>1.5×10^{-6} Kg·m²</td> </tr> </table> <p>Attachment inertial moment > Allowable inertial moment</p>	Finger opening and closing speed	Allowable inertial moment of attachment	Without speed controller	0.5×10^{-6} Kg·m ²	With speed controller 3/4 to 1 and 1/2 reverse rotation from fully close state	1.5×10^{-6} Kg·m ²	<p>Attachment inertial moment 0.38×10^{-6} (kg·m²) < Allowable inertial moment without speed controller 0.5×10^{-6} (kg·m²)</p> <p>Therefore, the attachment can be used without a speed controller.</p>
Finger opening and closing speed	Allowable inertial moment of attachment							
Without speed controller	0.5×10^{-6} Kg·m ²							
With speed controller 3/4 to 1 and 1/2 reverse rotation from fully close state	1.5×10^{-6} Kg·m ²							

Symbol

Symbol	Definition	Unit
Z	Central axis of finger rotation	—
Z1	Axis which contains center of gravity of attachment A part and is parallel to Z	—
Z2	Axis which contains center of gravity of attachment B part and is parallel to Z	—
I	Total inertial moment of attachment	kg·m ²
Iz1	Inertial moment around Z1 axis of attachment A part	kg·m ²
Iz2	Inertial moment around Z2 axis of attachment B part	kg·m ²
IA	Inertial moment around Z axis of attachment A part	kg·m ²
IB	Inertial moment around Z axis of attachment B part	kg·m ²
m1	Weight of attachment A part	kg
m2	Weight of attachment B part	kg
r1	Distance between axes Z and Z1	mm
r2	Distance between axes Z and Z2	mm

Limiting range of attachment inertial moment**MHC2-6D/MHCA2-6D**

Finger opening and closing speed	Allowable inertial moment of attachment	Weight (Guide)
Without speed controller ^{Note)}	0.5 x 10 ⁻⁶ kg·m ²	2g or less
With speed controller 3/4 to 1 and 1/2 reverse rotation from fully close state	1.5 x 10 ⁻⁶ kg·m ²	3.5g or less

MHC2-6S/MHCA2-6S

Finger opening and closing speed	Allowable inertial moment of attachment	Weight (Guide)
Without speed controller ^{Note)}	0.5 x 10 ⁻⁶ kg·m ²	2g or less
With speed controller 3/4 to 2 reverse rotation from fully close state	1.5 x 10 ⁻⁶ kg·m ²	3.5g or less

MHCM2-7S

Finger opening and closing speed	Allowable inertial moment of attachment	Weight (Guide)
Without speed controller ^{Note)}	0.3 x 10 ⁻⁶ kg·m ²	2g or less
With speed controller 1/2 to 1 3/4 reverse rotation from fully close state	1.0 x 10 ⁻⁶ kg·m ²	3.3g or less

*Applicable speed controller ——— Air gripper direct connection type AS1211F-M3
Use a meter-in type.

Note) In case of MHCM2-7S, provide a run off space
because the speed controller protrudes from the body
top surface by 0.6 mm.

Note) Sometimes the work piece may not be gripped precisely because of excessive speed in
finger opening and closing. Therefore, use a meter-in type speed controller to adjust the
finger opening and closing speed.

Angular Air Gripper Series MHC2-6/MHCA2-6

How to Order

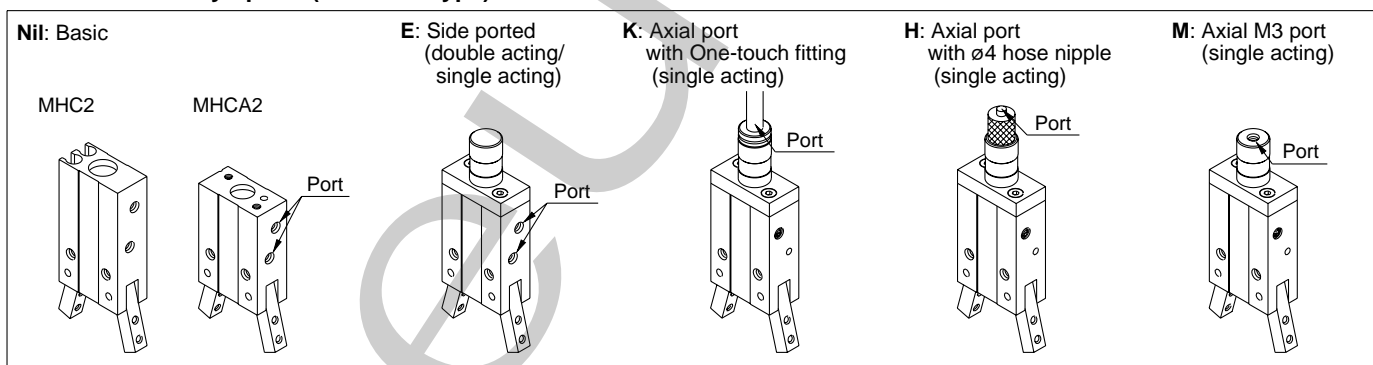
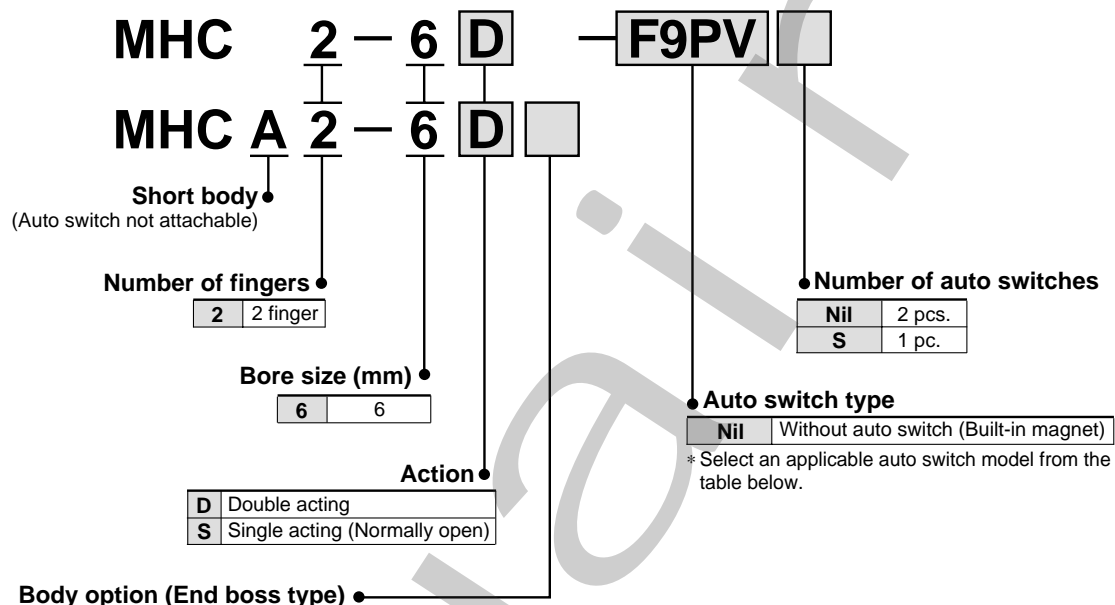

Applicable auto switches/ Refer to pages 15 through 17 for auto switch specifications.

Type	Special function	Electrical entry	Indicator light	Wiring (Output)	Load voltage		Auto switch type		Lead wire length (m)*			Note 1) Flexible lead wire (-61)	Applicable loads		
					DC	AC	Electrical entry direction	In-line	0.5 (Nil)	3 (L)	5 (Z)				
Solid state switch	-	Grommet	Yes	3-wire (NPN)	24V	12V	-	Perpendicular	F9NV	F9N	●	●	○	-	Relay PLC
				3-wire (PNP)				F9PV	F9P	●	●	○			
				2-wire				F9BV	F9B	●	●	○			

*Lead wire length symbol: 0.5m Nil (Example) F9N
3m L (Example) F9NL
5m Z (Example) F9NZ

*Auto switches marked "O" are produced upon receipt of order.
Note 1) For the flexible wire specification, enter -61 after the part number.

(Example) When ordering with air gripper

MHC2-6D-F9NVS-61

Flexible wire

When ordering only auto switch

D-F9PL-61

Flexible wire

Angular Air Gripper Series MHC2-6/MHCA2-6

Specifications

Fluid		Air
Operating pressure	Double acting	0.15 to 0.6MPa
	Single acting: Normally open	0.3 to 0.6MPa
Ambient and fluid temperature		-10 to 60°C
Repeatability		±0.02mm
Maximum operating frequency		180c.p.m
Lubrication		Non-lube
Action		Double acting, Single acting (Normally open)
Auto switch (Optional) ^{Note)}		Solid state switch (3-wire, 2-wire)

Note) Refer to pages 15 through 17 for auto switch specifications.



Model

Action	Model	Cylinder bore (mm)	Holding moment ^{Note)} (Effective value) N·m	Opening/Closing angle (Both sides)	Note 2)
					Weight g
Double acting	MHC2-6D	6	0.038	30° to -10°	22
	MHCA2-6D	6			19
Single acting (Normally open)	MHC2-6S	6	0.024	30° to -10°	22
	MHCA2-6S	6			19

Note 1) At the pressure of 0.5MPa

Note 2) Excluding the auto switch weight.

Option

●Body option/End boss type

Symbol	Piping position	Piping port type	Applicable model	
			Double acting	Single acting
Nil	Standard	M3 x 0.5	●	●
E	Side ported	M3 x 0.5	●	●
K	Axial port	With ø4 one-touch fitting	—	●
H		With ø4 hose nipple	—	●
M		M3 x 0.5	—	●

Symbol

Double acting

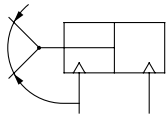

Single acting

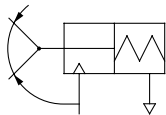

Series MHC2-6/MHCA2-6

Construction

MHC2-6

Double acting/with fingers open

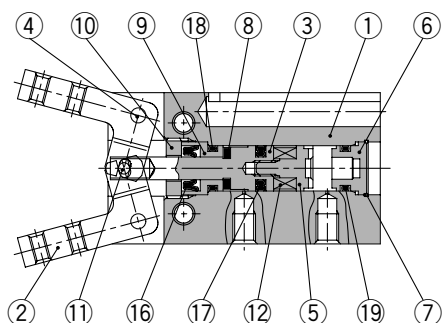

Double acting/with fingers closed

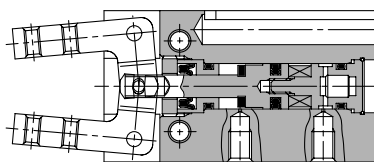

Single acting

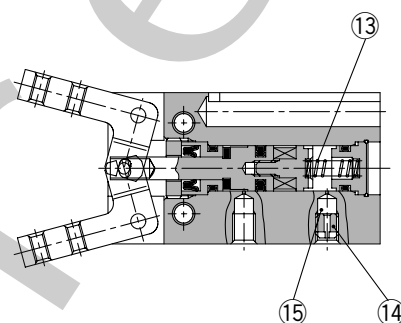

Parts list

No.	Description	Material	Note
1	Body	Aluminium alloy	Hard anodized
2	Finger	Stainless steel	Heat treatment
3	Piston	Stainless steel	
4	Lever shaft	Stainless steel	Nitriding
5	Magnet holder	Stainless steel	
6	Cap	Aluminium alloy	Hard anodized
7	Clip	Stainless steel	
8	Bumper	Urethane rubber	
9	Holder	Brass	Electroless nickel plated
10	Holder lock	Stainless steel	

Parts list

No.	Description	Material	Note
11	Needle roller	High carbon chromium bearing steel	
12	Magnet	Rare earth magnet	Nickel plated
13	NO spring	Piano wire	Zinc chromated
14	Exhaust plug	Brass	Electroless nickel plated
15	Exhaust filter	Resin	
16	Rod seal	NBR	
17	Piston seal	NBR	
18	Gasket	NBR	
19	Gasket	NBR	

Replacement parts

Description	Kit no.	Main parts	Note
Seal kit	MHC6-PS	16, 17, 18, 19	

MHCA2-6 (Short body)

Double acting/with fingers open

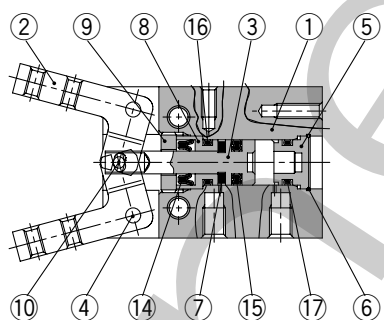

Double acting/with fingers closed

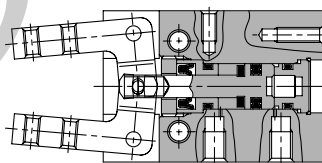

Single acting

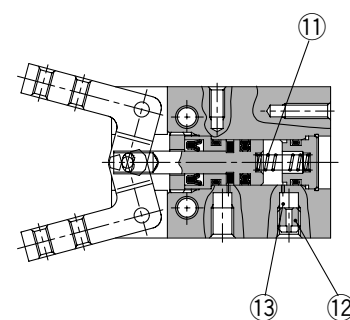

Parts list

No.	Description	Material	Note
1	Body	Aluminium alloy	Hard anodized
2	Finger	Stainless steel	Heat treatment
3	Piston	Stainless steel	
4	Lever shaft	Stainless steel	Nitriding
5	Cap	Aluminium alloy	Hard anodized
6	Clip	Stainless steel	
7	Bumper	Urethane rubber	
8	Holder	Brass	Electroless nickel plated
9	Holder lock	Stainless steel	

Parts list

No.	Description	Material	Note
10	Needle roller	High carbon chromium bearing steel	
11	NO spring	Piano wire	Zinc chromated
12	Exhaust plug	Brass	Electroless nickel plated
13	Exhaust filter	Resin	
14	Rod seal	NBR	
15	Piston seal	NBR	
16	Gasket	NBR	
17	Gasket	NBR	

Replacement parts

Description	Kit no.	Main parts	Note
Seal kit	MHCA6-PS	14, 15, 16, 17	

Dimensions

MHC2-6 □

4-M2 x 0.4 through
(Attachment mounting threads)

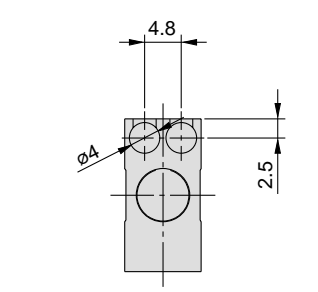
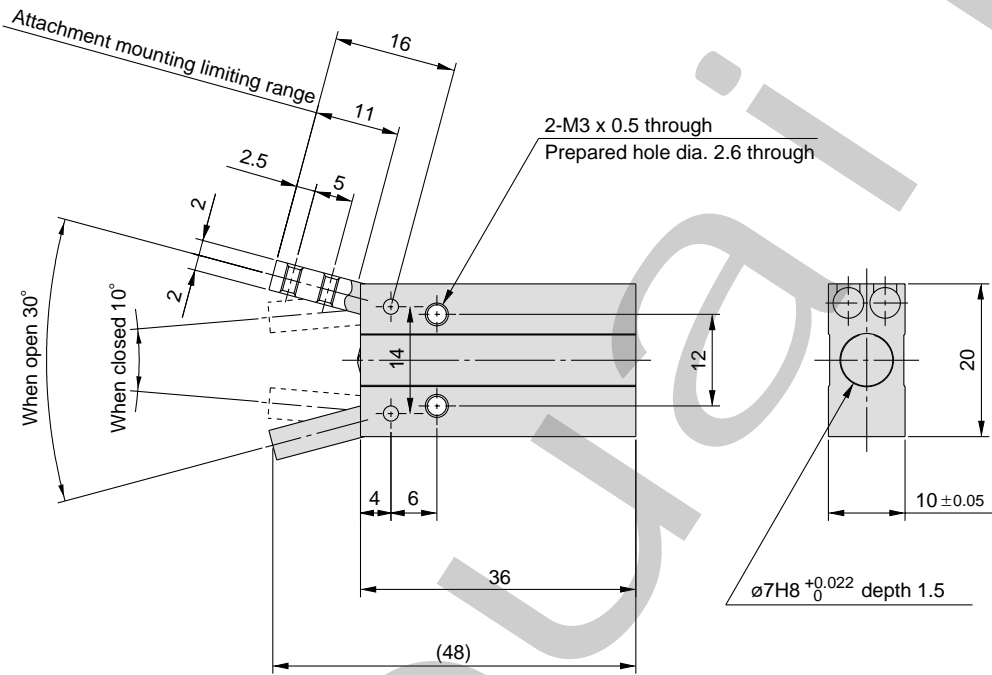
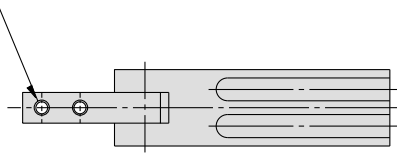

Auto switch mounting groove dimensions

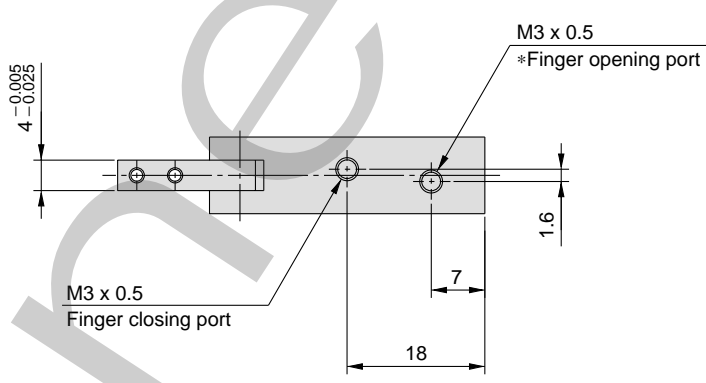

*In the case of MHC2-6S, finger opening port is a breathing hole.

Series MHC2-6/MHCA2-6

Dimensions

MHCA2-6□ (Short body)

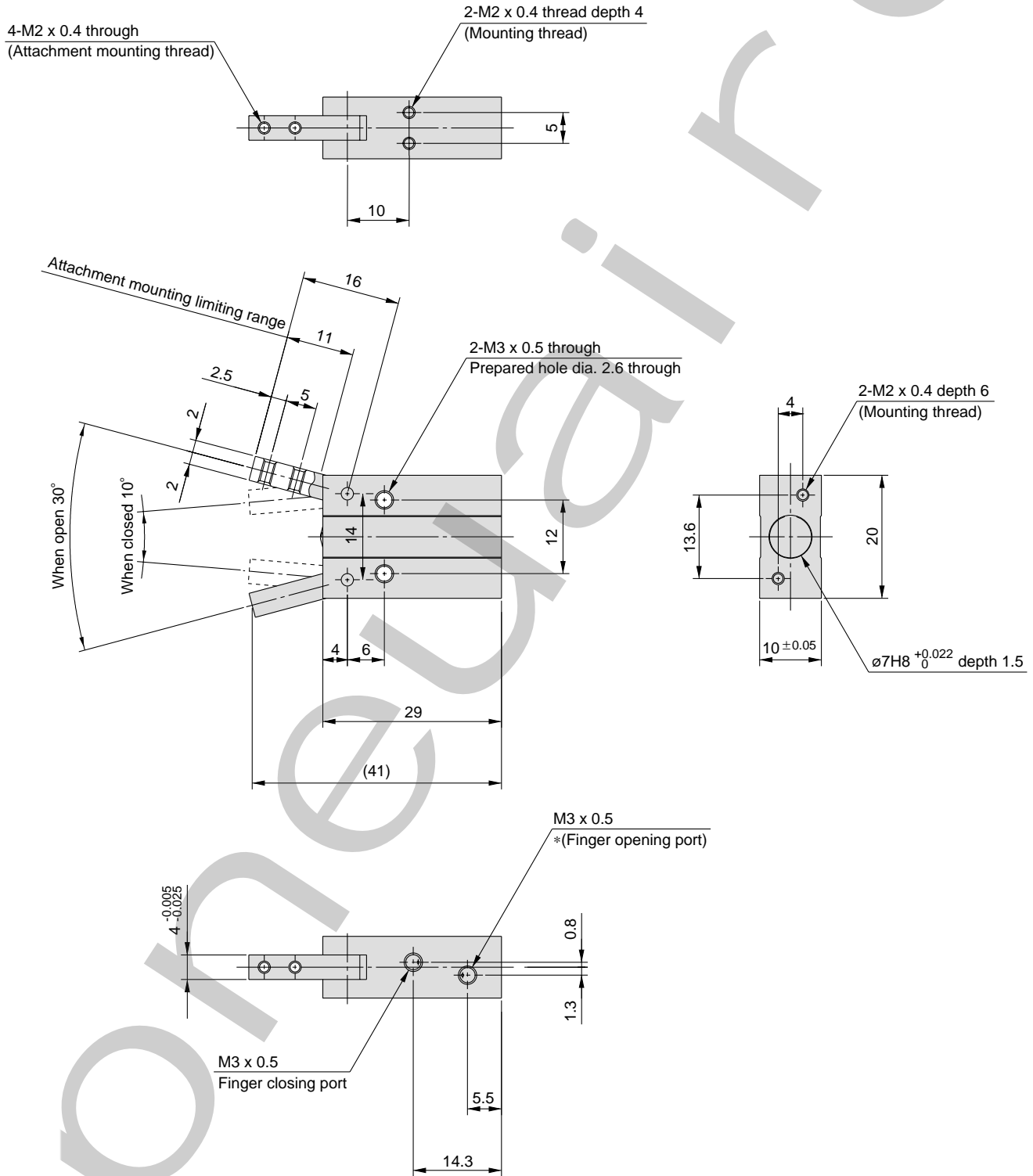

*In the case of MHCA2-6S, finger opening port is a breathing hole.

Auto Switch Hysteresis

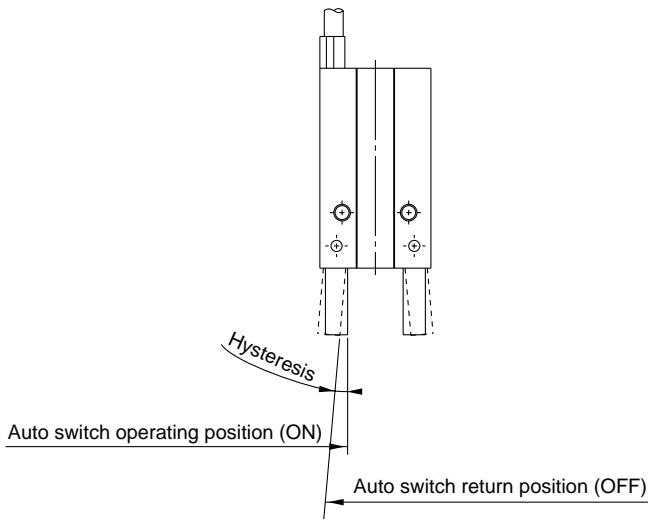

Hysteresis

Model	D-F9□(V)
MHC2-6□	4°

Auto Switch Mounting

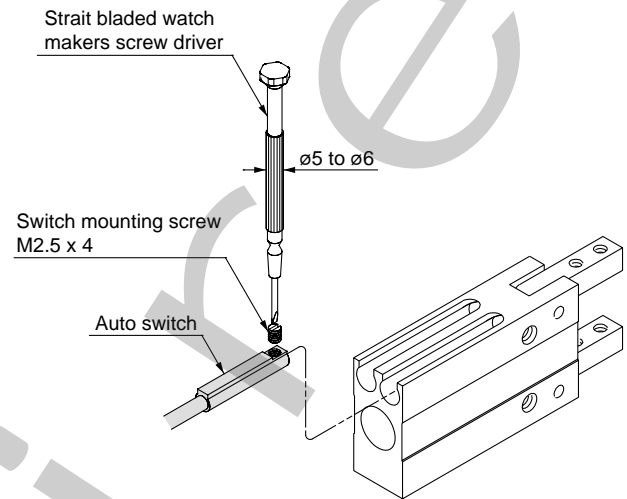

Note) Use a screwdriver with a grip diameter of 5 to 6 mm to tighten the auto switch mounting screw. The tightening torque should be about 0.05 to 0.1N·m. When you begin to feel that the screw is being tightened, turn it further by 90°.

Auto Switch Protrusion from the Body End Surface

- The amount of auto switch protrusion from the body end surface is shown in the table below.
- Use this as a standard when mounting, etc.

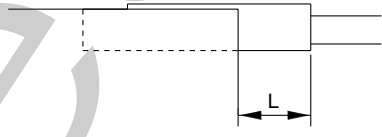
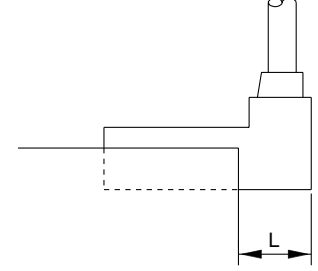
Lead wire type	In-line entry		Perpendicular entry	
	Illustration		Illustration	
Model		D-F9		D-F9□V
MHC2-6□	Open	6.5	Open	4.5
	Close	9	Close	7

Series MHCA2

Body Option: End Boss Type

Applicable Model

Symbol	Piping position	Piping port type	Applicable model	
			Double acting	Single acting
E	Side ported	M3 x 0.5	●	●
H	Axial port	With ø4 hose nipple	—	●
K		With ø4 one-touch fitting	—	●
M		M3 x 0.5	—	●

Side Ported [E]

MHCA2-6□E

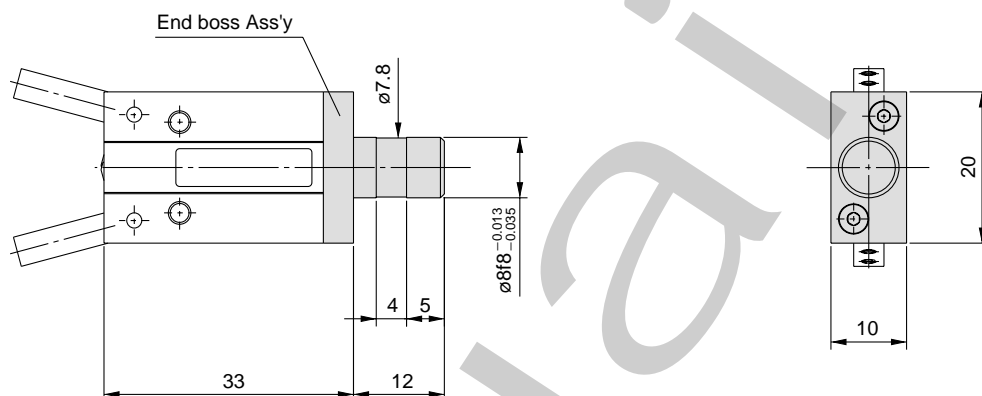

*The specifications and dimensions not given above are identical with those of the standard type.

Axial Port (with hose nipple) [H]

MHCA2-6SH

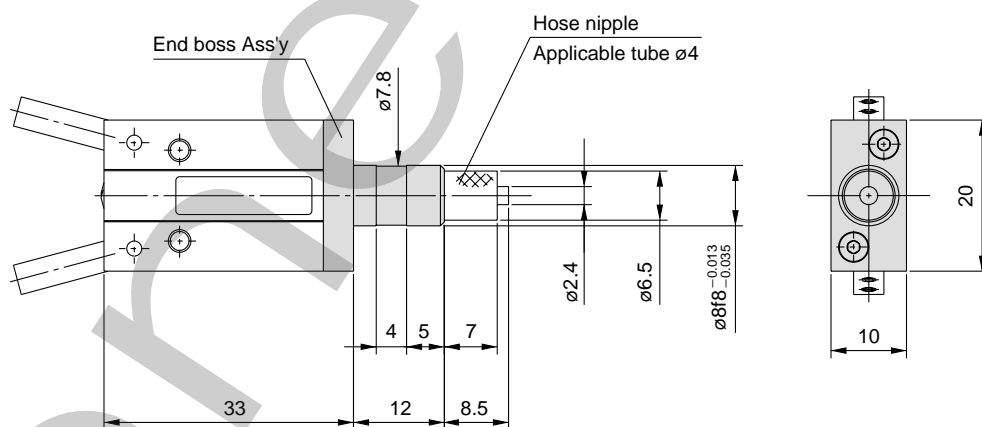

*The specifications and dimensions not given above are identical with those of the standard type.

Applicable tube

Description/Model	Nylon tube	Soft nylon tube	Polyurethane tube	Polyurethane coil tube
Specifications	T0425	TS0425	TU0425	TCU0425B-1
Outside diameter mm	4	4	4	4
Max. operating pressure MPa	1.0	0.8	0.5	0.5
Min. bending radius mm	13	12	10	—
Operating temperature °C	-20 to 60	-20 to 60	-20 to 60	-20 to 60
Material	Nylon 12	Nylon 12	Polyurethane	Polyurethane

Axial Port (with One touch fitting) [K]

MHCA2-6SK

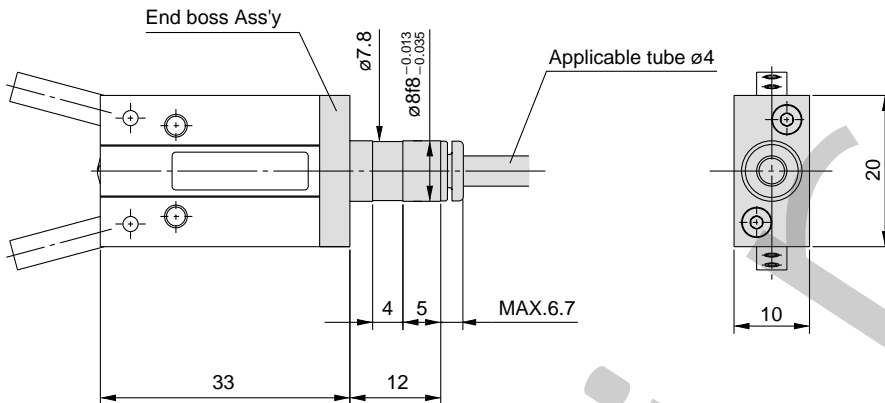

*The specifications and dimensions not given above are identical with those of the standard type.

Applicable tube

Description, model	Nylon tube	Soft nylon tube	Polyurethane tube	Polyurethane coil tube
	T0425	TS0425	TU0425	TCU0425B-1
Outside diameter mm	4	4	4	4
Max. operating pressure MPa	1.0	0.8	0.5	0.5
Min. bending radius mm	13	12	10	—
Operating temperature °C	-20 to 60	-20 to 60	-20 to 60	-20 to 60
Material	Nylon12	Nylon12	Poly urethane	Poly urethane

Axial Port (with M3 port) [M]

MHCA2-6SM

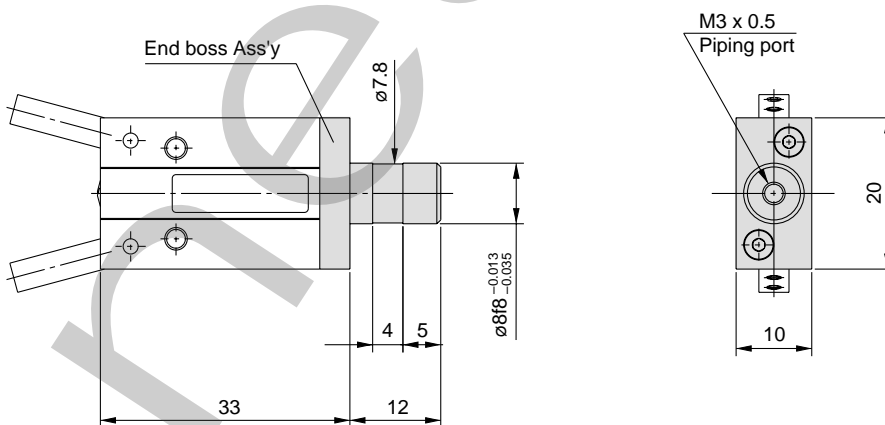

*The specifications and dimensions not given above are identical with those of the standard type.

Weights

Model	End boss type (symbol)			
	E	H	K	M
MHCA2-6□□	23	23	23	23

Unit: g

Angular
Air Gripper

Compact Type MHCM2-7S

How to Order



MHC M 2 - 7 S

Compact type

Number of fingers

2 2 finger

Action

S Single acting (Normally open)

Bore size (mm)

7 7

Specifications

Fluid	Air
Operating pressure	0.4 to 0.6MPa
Ambient and fluid temperature	-10 to 60°C
Repeatability	±0.02mm
Maximum operating frequency	180c.p.m.
Lubrication	Non-lube
Action	Single acting (Normally open)

Symbol

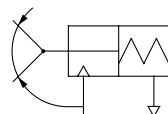

Model

Action	Model	Cylinder bore (mm)	Holding moment ^{Note)} (Effective value) N·m	Opening/Closing angle (Both sides)	Weight g
Single acting (Normally open)	MHCM2-7S	7	0.017	20° to -7°	9.5

Note) At the pressure of 0.5MPa

Construction/MHCM2-7S (Compact type)

Single acting/with open

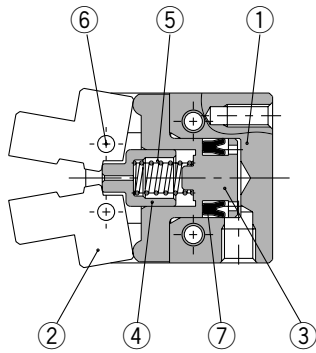

With closed

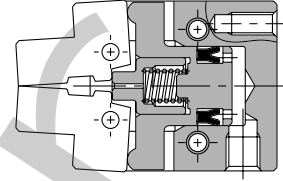

Parts list

No.	Description	Material	Note	Replacement parts order no.
1	Body	Aluminium alloy	Hard anodized	
2	Finger	Stainless steel	Heat treatment	
3	Piston	Stainless steel	Heat treatment	
4	Pusher	Stainless steel		
5	Spring	Piano wire	Zinc chromated	
6	Needle roller	High carbon chromium bearing steel		
7	Piston seal	NBR		MYN-4

Dimensions

MHCM2-7S

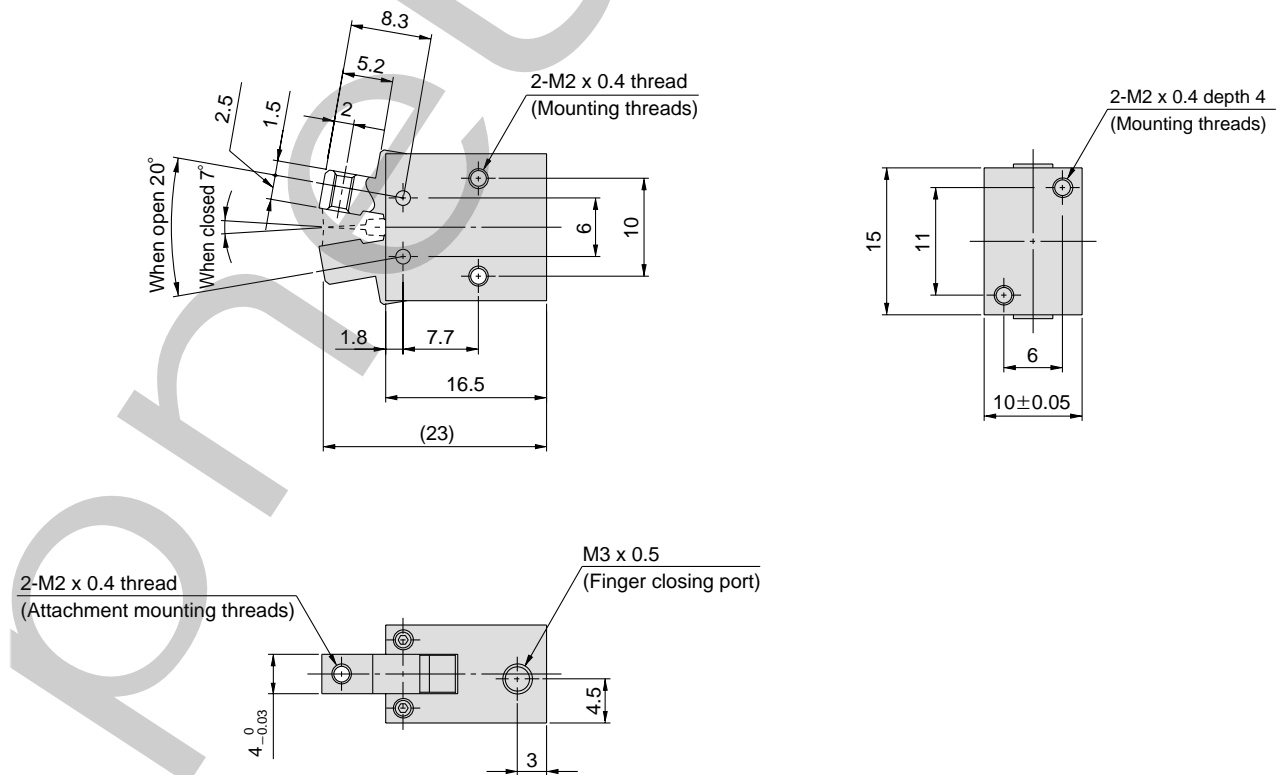

Series MHC2 Auto Switch Common Specifications

Auto Switch Common Specifications

Type	Solid state switch
Operating time	1ms or less
Shock resistance	1000m/s ²
Insulation resistance	50MΩ or more at 500VDC (Between lead wire and case)
Withstand voltage	1000VAC for 1min. (Between lead wire and case)
Ambient temperature	-10 to 60°C
Enclosure	IEC529 standard IP67, JISC0920 watertight construction

Lead Wire Length

Lead wire length indication

(Example)

D-F9P **L**

●Lead wire length

Nil	0.5m
L	3m
Z	5m

Note 1) Lead wire length Z: 5m applicable auto switch
Solid state switch: All models are produced upon receipt of order
(as standard).

Note 2) For the flexible wire specification, enter -61 after the part number.

(Example) D-F9PL-**61**

●Flexible wire specifications

Lead Wire Color Changes

The lead wire colors of P/A auto switches have been changed as shown below to satisfy IEC947-5-2 standards for production beginning September, 1996 and thereafter. Take special care regarding wire polarity during the time that old colors still coexist with the new colors.

2-wire

	Old	New
Output (+)	Red	Brown
Output (-)	Black	Blue

3-wire

	Old	New
Power supply	Red	Brown
GND	Black	Blue
Output	White	Black

Series MHC2 Auto Switch Connections and Examples

Basic Wiring

Solid state 3-wire, NPN

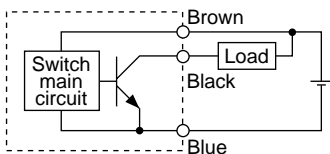

When power source for switch and load is not common.

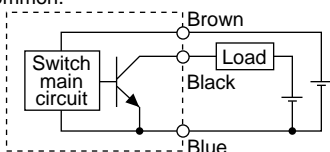

Solid state 3-wire, PNP

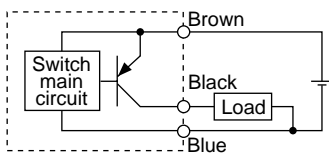

2-wire system <Solid state>

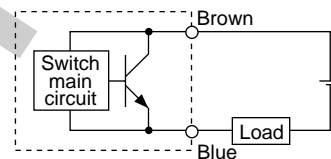
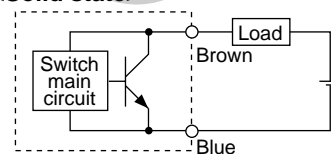

Examples of Connection to PLC (Sequence Controller)

Sink input specification 3-wire, NPN

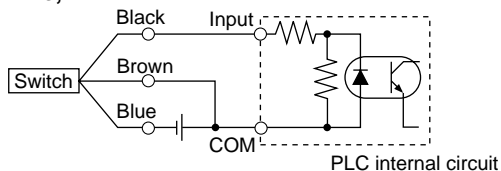

Source input specification 3-wire, PNP

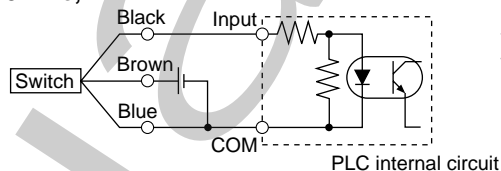

Connect according to the input specification of the sequence controller, because the connection method varies with the input specification of the sequence controller.

2-wire

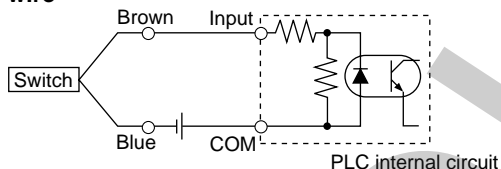

2-wire

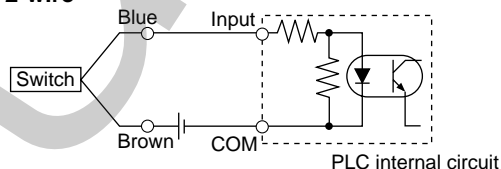

Connection Examples for AND (Series) and OR (Parallel)

3-wire

AND connection for NPN output (Using relays)

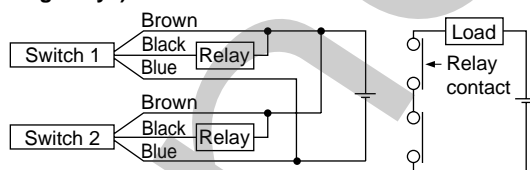

AND connection for NPN output (Performed with switches only)

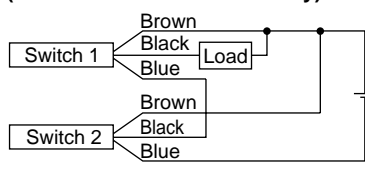

OR connection for NPN output

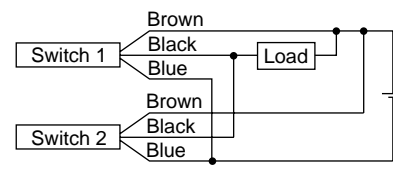

The indicator lights will light up when both switches are turned ON.

2-wire with 2 switch AND connection

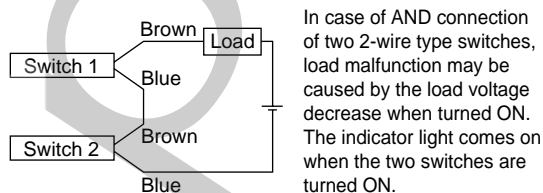

In case of AND connection of two 2-wire type switches, load malfunction may be caused by the load voltage decrease when turned ON. The indicator light comes on when the two switches are turned ON.

$$\begin{aligned} \text{Load voltage when turned ON} &= \text{Power supply voltage} - \text{Residual voltage} \times 2 \text{ pcs.} \\ &= 24\text{V} - 4\text{V} \times 2 \text{ pcs.} \\ &= 16\text{V} \end{aligned}$$

(Example) Power supply: 24VDC
Internal voltage drop: 4V

2-wire with 2 switch OR connection

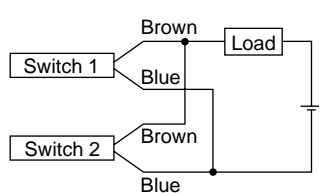

<Solid state>
In case of OR connection of two 2-wire type switches, load malfunction may be caused by the load voltage increase when turned OFF.

$$\begin{aligned} \text{Load voltage when turned OFF} &= \text{Leakage voltage} \times 2 \text{ pcs.} \times \text{Load impedance} \\ &= 1\text{mA} \times 2 \text{ pcs.} \times 3\text{k}\Omega \\ &= 6\text{V} \end{aligned}$$

(Example) Load impedance: 3kΩ
Current leakage: 1mA

Solid State Switch/Direct Mounting D-F9N(V), D-F9P(V), D-F9B(V)

Grommet



Auto Switch Specifications

D-F9□, D-F9□V (With indicator light)						
Auto switch symbol	D-F9N	D-F9NV	D-F9P	D-F9PV	D-F9B	D-F9BV
Electrical entry	In-line	Perpendicular	In-line	Perpendicular	In-line	Perpendicular
Wiring method	3-wire				2-wire	
Output method	NPN		PNP		—	
Applicable load	IC circuit, Relay, PLC				24VDC Relay, PLC	
Power supply	5, 12, 24VDC (4.5 to 28V)				—	
Current consumption	10mA or less				—	
Load voltage	28VDC or less		—		24VDC (10 to 28VDC)	
Load current	40mA or less		80mA or less		5 to 40mA	
Internal voltage drop	1.5V or less (0.8V or less at 10mA load current)		0.8V or less		4V or less	
Leakage current	100μA or less at 24VDC				0.8mA or less	
Indicator light	Red LED lights when ON					

O Lead wire — Heavy duty oil resistant, $\phi 2.7$, 3 cores (Brown, Black, Blue), 0.15mm², 2 cores (Brown, Blue), 0.18mm², 0.5m

Note 1) Refer to page 15 for solid state switch common specifications.

Note 2) Refer to page 15 for lead wire length.

Auto Switch Internal Circuits

D-F9N, F9NV

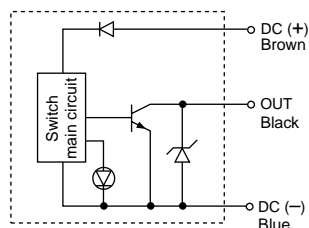

D-F9P, F9PV

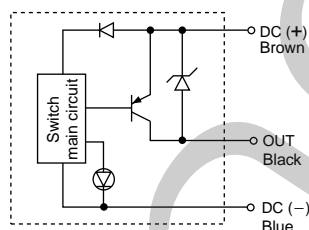

D-F9B, F9BV

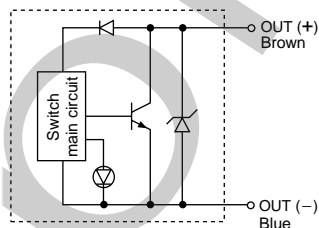

Auto Switch Weights

Unit: g

Auto switch part no.	D-F9N(V)	D-F9P(V)	D-F9B(V)
Lead wire length (m)	0.5	7	6
	3	37	31
	5	61	51

Auto Switch Dimensions

D-F9□

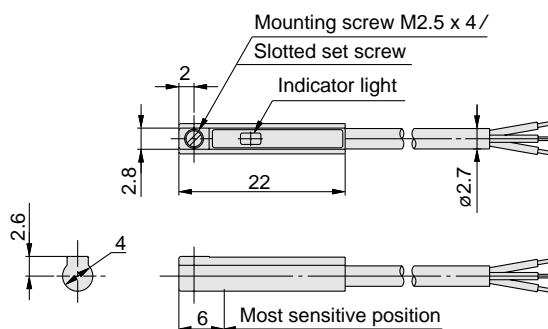

D-F9□V

