

Series 11-22-MHR3

3 Finger Rotary Actuated Air Gripper
Size: 10, 15

How to Order



Clean series
11 Vacuum suction type

11 - M D H R 3 - 10 R - M9B S

22 - M D H R 3 - 10 R - M9B S

Copper, fluorine and silicone-free + Low particle generation
22 Vacuum suction type

Number of fingers
3 | 3 fingers

Nominal size
10
15

Auto switch
Nil | Without auto switch (Built-in magnet)



Number of auto switches
Nil | 2 pcs.
S | 1 pc.

Built-in magnet

Nil	No
D	With magnet (For auto switch)

Connecting port

R: Body side	E: Axial side
Port	Port

* Only R type is available for "Without auto switch".

Model

Vacuum suction type	Model	Nominal size	Port size	Lubrication	Action	Gripping force N (Effective value at 0.5 MPa) (Note 1)		Open/Close stroke (Diameter)			Weight (g)
						External	Internal	Finger closing width (mm)	Finger opening width (mm)	Stroke (mm)	
11- 22-	MHR3-10	10	M3 x 0.5	Non-lube	Double acting	7	6.5	16	22	6	125 (130)
	MDHR3-10					13	12	19	27	8	230 (235)
11- 22-	MHR3-15	15	M3 x 0.5	Non-lube	Double acting	13	12	19	27	8	230 (235)
	MDHR3-15					13	12	19	27	8	230 (235)

Note 1) Refer to the **WEB catalog** for details of gripping force at each gripping point.
Value of effective gripping force is measured at the middle of open/close stroke.
Note 2) Values in () show MDHR weight, but it does not include auto switch weight.

Specifications

Item	Nominal size	
	10	15
Operating pressure	0.2 to 0.6 MPa	0.15 to 0.6 MPa
Ambient and fluid temperature	0 to 60°C	
Repeatability	±0.01 mm	
Maximum operating frequency	180 c.p.m.	
Grease	11-: Fluorine grease 22-: Lithium soap based grease	
Cleanliness class (ISO class)	11-/22-: Class 3	

Suction Flow Rate of Vacuum Suction Type (Reference values)

Size	Suction flow rate L/min (ANR)
10/15	1

Auto Switch Specifications (Refer to the WEB catalog for further information on auto switches.)

Type		Auto switch model	Load voltage	Load current range	Indicator light	Applicable load
Solid state auto switch	2-wire	D-M9B(V)	24 VDC (10 to 28 VDC)	5 to 30 mA	Yes	24 VDC relay, PLC
	3-wire	D-M9N(V)	28 VDC or less	50 mA or less	Yes	

Refer to page 946 for the applicable auto switch list.

PLC: Programmable Logic Controller

Auto Switch Hysteresis

¹¹⁻₂₂₋MDHR3

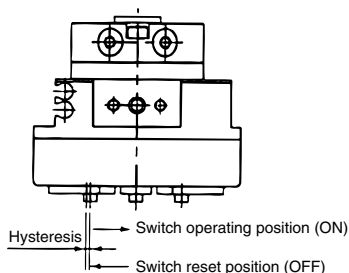

Please refer to the table as a guide when setting auto switch positions.

Model	Hysteresis (Max. value) (mm)
¹¹⁻ ₂₂₋ MDHR3-10	0.3
¹¹⁻ ₂₂₋ MDHR3-15	0.5

Protrusion of Auto Switch from Edge of Body

The maximum protrusion of auto switch (when fingers are fully open) from the edge of the body is shown in the table below. Use the table as a guideline for mounting.

¹¹⁻₂₂₋MDHR3-10

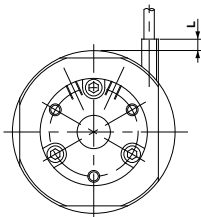

When auto switch D-M9□□ is used

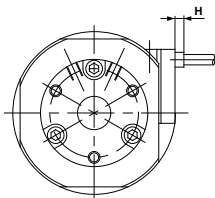

When auto switch D-M9□V is used

Max. protrusion of auto switch from edge of body: L, H (mm)

Auto switch model	D-M9□□	D-M9□V
L	—	—
H	—	2.3

¹¹⁻₂₂₋MDHR3-15

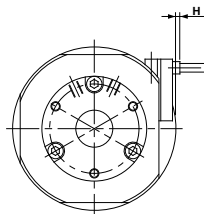

When auto switch D-M9□V is used

Max. protrusion of auto switch from edge of body: H (mm)

Auto switch model	D-M9□V
H	1.3

The auto switch will not protrude in the case of D-M9□□.

Without Auto Switch: 11-22-MHR3-10R

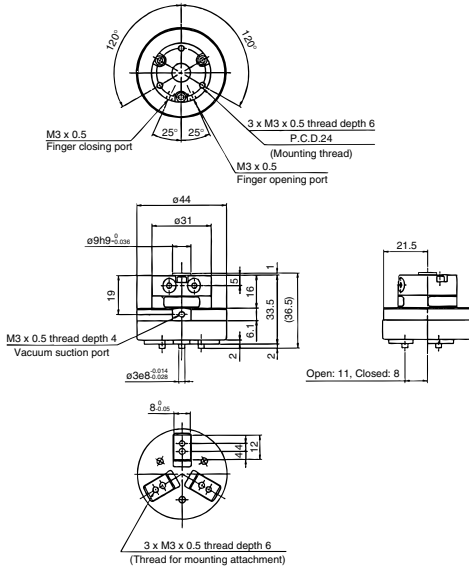

With Auto Switch: 11-22-MDHR3-10R

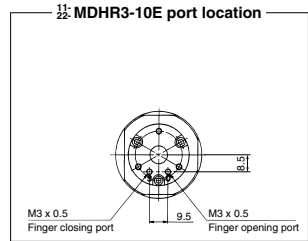
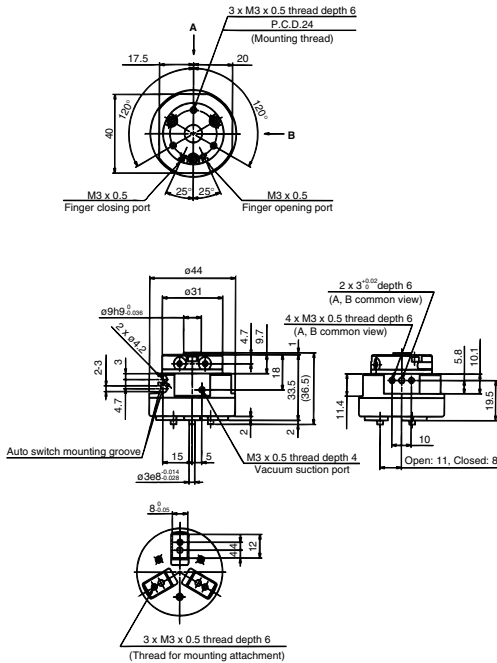

Directional Control Valves

Air Cylinders

Rotary Actuators

Air Grippers

Air Preparation Equipment

Modular F. R.

Pressure Control Equipment

Fittings & Tubing

Flow Control Equipment

Pressure Switches/ Pressure Sensors

Without Auto Switch: 11-22-MHR3-15R

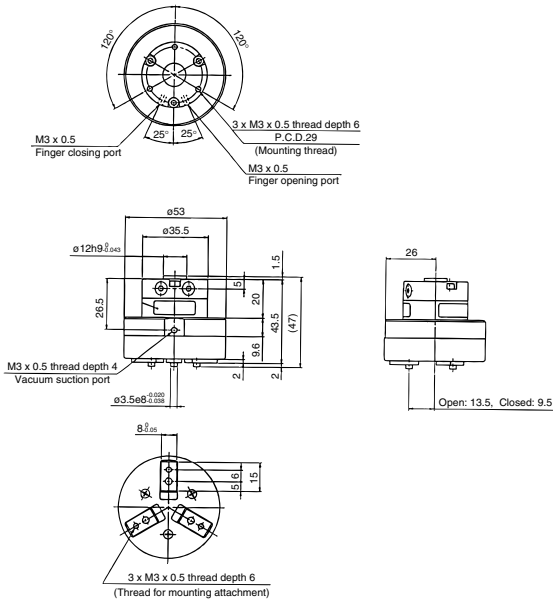

With Auto Switch: 11-22-MDHR3-15R

