

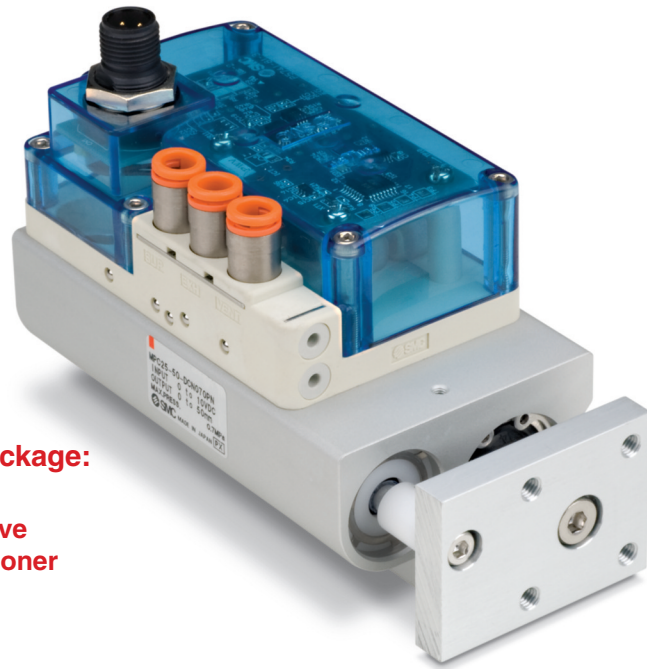

## Series MPC

# Low Cost Positioning Cylinder



### All in one package:

- Cylinder
- Solenoid Valve
- Linear Positioner
- Controller

### Operating Principle

A pneumatic cylinder with integral position control utilizing 0-10VDC or 4-20mA input signal. Position control is a continuous servo-loop, taking a feedback signal from the linear sensor. It will keep the target position by controlling pressure on the cylinder by way of opening and closing the solenoid valves. Unlike analog control for a servo valve, the solenoid valves mounted internally are a simple ON-OFF control. Cylinder speed is limited by the fixed orifice. There is no adjustment for acceleration or speed. If an external force stronger than the supply pressure is applied, the cylinder will return to the target position when the external force is removed. The cylinder has an output signal to give position feedback to a customer's controller, 1-5V representing full stroke. Standard ball bushings protect against side load.

### Application Example

Aligning different sizes of packages on conveyor:

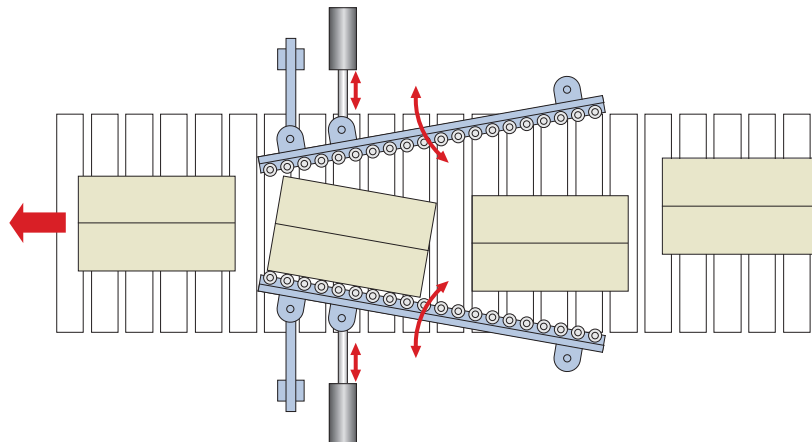

## MPC Series Specifications

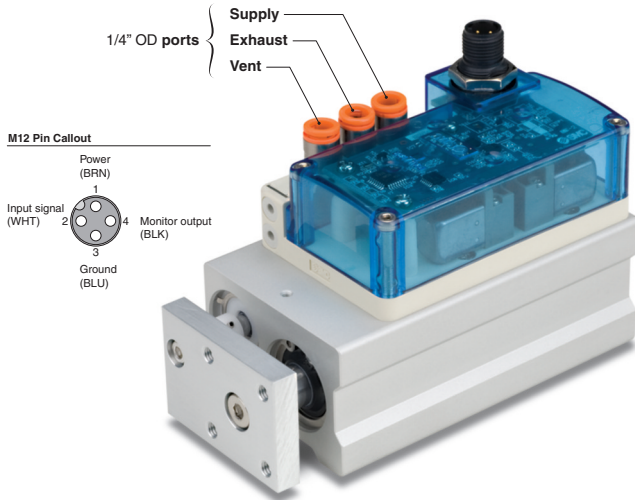

Specifications Table				
Cylinder	Bore	25mm	40mm	
	Stroke	50mm	100mm	
	Rod diameter	12mm	16mm	
	Thrust at 80psi (theoretical)	Extend	344 N (78 lbf)	880 N (199 lbf)
		Retract	264 N (59 lbf)	739 N (166 lbf)
	Maximum pressure	0.7 Mpa (101 psi)		
	Speed (w/fixed orifice) at max. press.	25 mm/s		
Power supply voltage	24 VDC			
Control	Maximum power consumption	5 W		
	Input signal	0-10V or 4-20mA [Sink Type]		
	Output signal	1-5 VDC full stroke		
	Operating temperature	32~122°F (0-50°C)		
	Repeatability	±0.5mm (50mm stroke) OR ±1.0mm (100mm stroke)		
	Protection	IP65 equivalent		

## MPC Cylinders

Part Numbers	Input Type	Bore	Stroke
MPC25-50-DCN070PN	0 ~ 10V	25mm	50mm
MPC40-100-DCN069PN	0 ~ 10V	40mm	100mm
MPC25-50-DCN708SN	4 ~ 20mA	25mm	50mm
MPC40-100-DCN709SN	4 ~ 20mA	40mm	100mm

## Cables

Part Numbers	Type
P398020-501-3	Straight type M12 connector
P398020-500-3	Right angle type M12 connector

## Working Principle

- Linear displacement sensor gives feedback signal to controller.
- Controller takes input signal (analog) and controls cylinder position by supplying and exhausting pressure to cylinder.
- When it reaches the target position, controller captures pressure at both sides of piston to stop the cylinder.

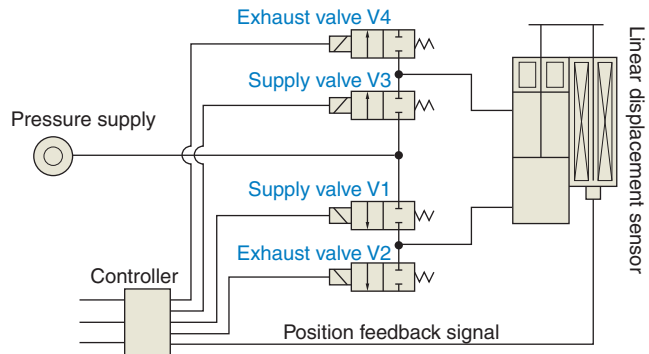

## Application Example

Air conveyor blows air under the cans to move them freely, requiring a ceiling to contain the cans. The ceiling height must be changed when different sized cans come into the conveyor.

Currently a 3-position cylinder is used but a solution is needed when more than three types of cans are produced.

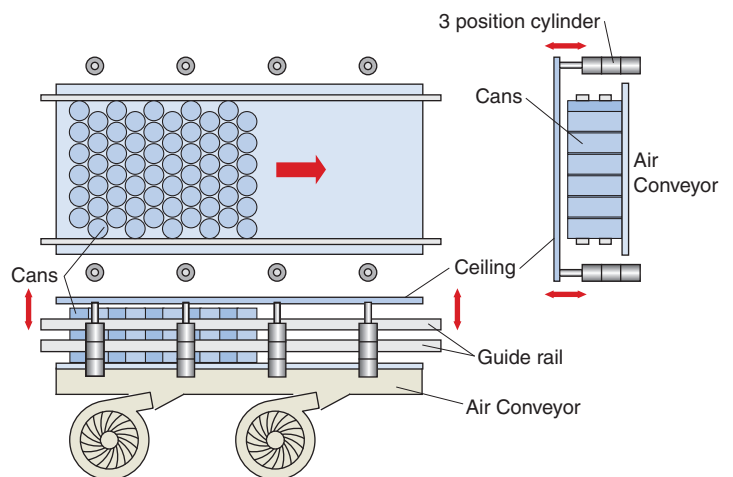

### SMC Corporation of America

10100 SMC Boulevard, Noblesville, Indiana  
 46060, U.S.A.  
 Phone: 317-762-7621 Fax: 317-899-3102  
 www.smcusa.com

### SMC Pneumatics (Canada) Ltd.

2715 Bristol Circle, Oakville, Ontario  
 L6H 6X5 Canada  
 Phone: 800-762-7621 Fax: 905-812-8686  
 www.smc Pneumatics.ca