

Height reduced by up to

36* %

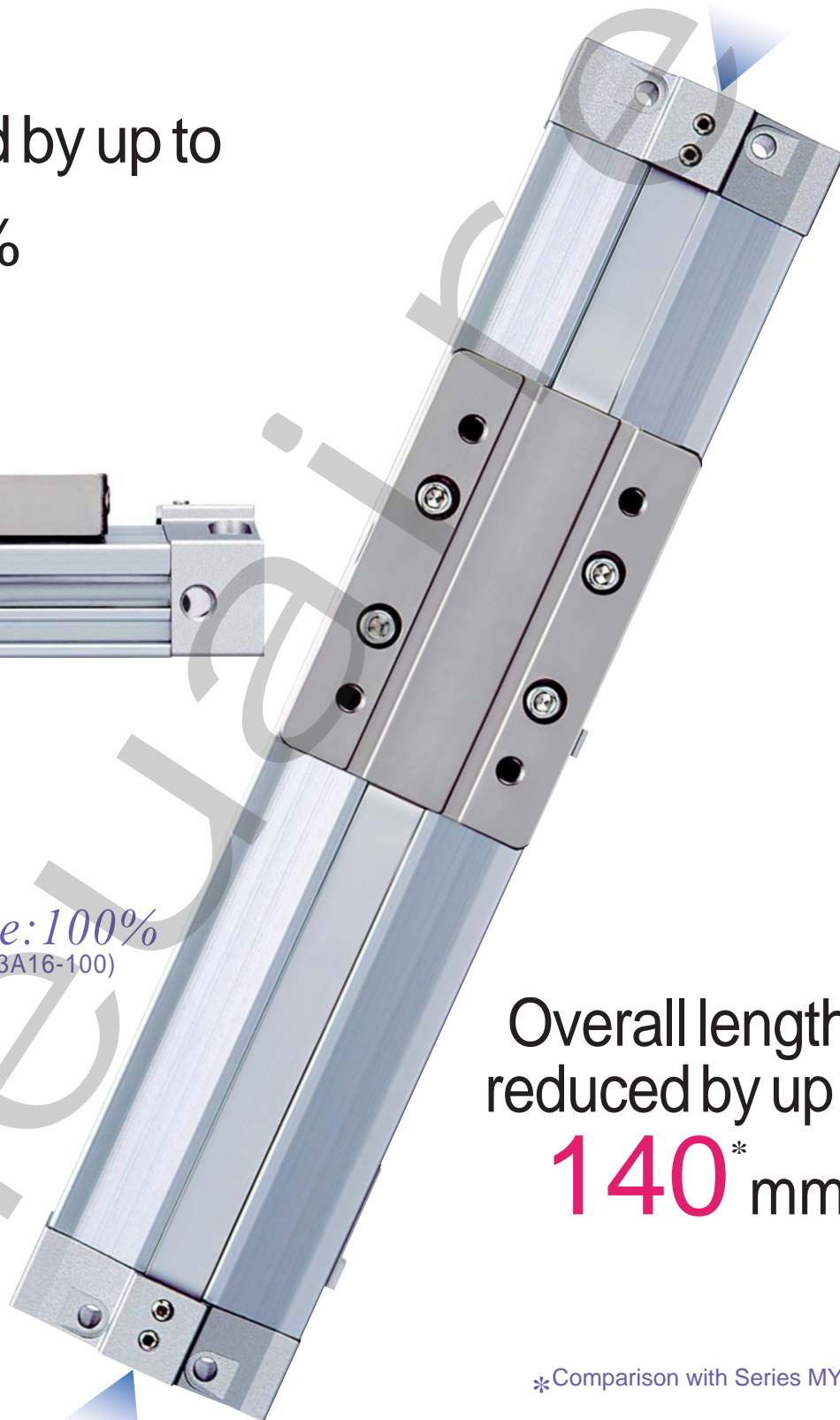

Scale: 100%
(MY3A16-100)



Overall length
reduced by up to

140* mm

*Comparison with Series MY1B

Mechanical Joint Rodless Cylinder/Basic type

Series **MY3A/3B**

ø16, ø25, ø40, ø63

Coming out in October, 2001

Compact, low profile design offering same functions as Series MY1B

Overall length(Z) Up to 140mm reduction

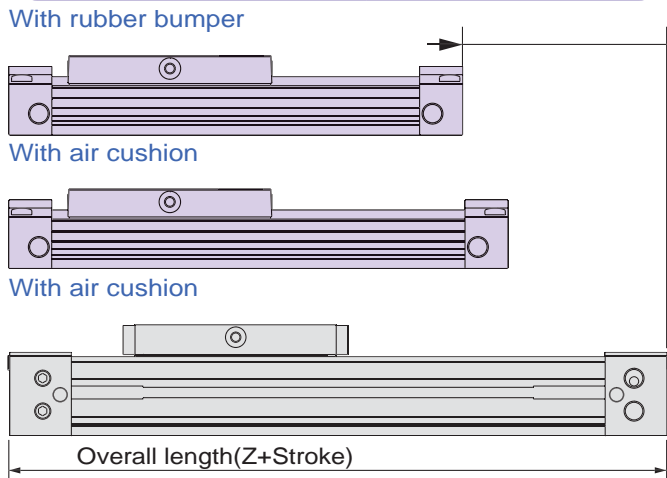

Z dimension (mm)

Series	ø16	ø25	ø40	ø63
MY3A	110	150	240	320
MY3B	122	178	276	356
MY1B	160	220	340	460

Height(H) Up to 36% reduction

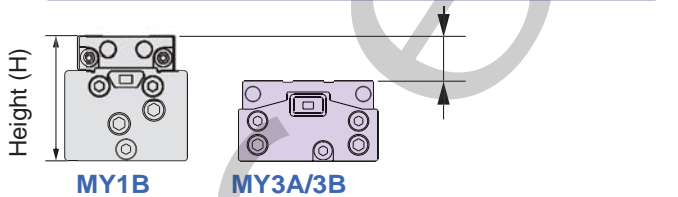

Height(H) (mm)

Series	ø16	ø25	ø40	ø63
MY3A MY3B	27	37	54	84
MY1B	37	54	84	116

Weight Up to 53% reduction

Weight (kg)

Series	ø16	ø25	ø40	ø63
MY3A	0.34	0.87	2.95	8.26
MY3B	0.35	0.97	3.08	8.99
MY1B	0.73	1.57	4.41	14.5

*For 100mm stroke

