

New

Safety Standard ISO13849-1 Certified*2 (Corresponding to Category 2 to 4)

CE C-UL US *1. Refer to page 2 for compliant products.

RoHS

* 2. Refer to page 2 for certified products.

3 Port Solenoid Valve/ Residual Pressure Release Valve with Detection of Main Valve Position

With Detection of Main Valve Position

Category 2

The detecting function of the main valve position detects a mismatch between the input signal and valve operation.

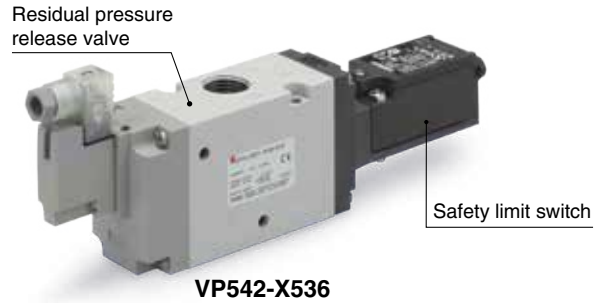

Redundant system can be constructed easily.

Category 3, 4

Dual Residual Pressure Release Valve VP544-X538

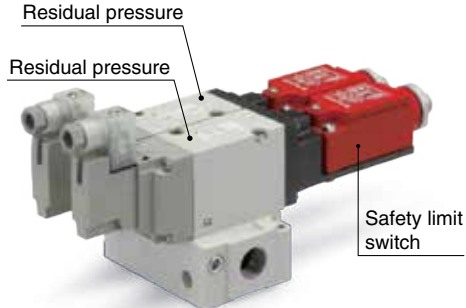

With Soft Start-up Function VP544-X555

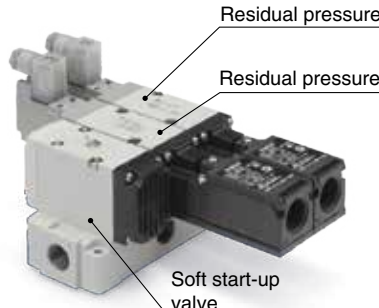

Dual Residual Pressure Release Valve VG342-X87



Redundant System

A system in which even if one part fails, the whole system will fulfill its required function. This is usually achieved by having dual channels of operation, such as dual valves, dual wiring, dual guard switches etc.

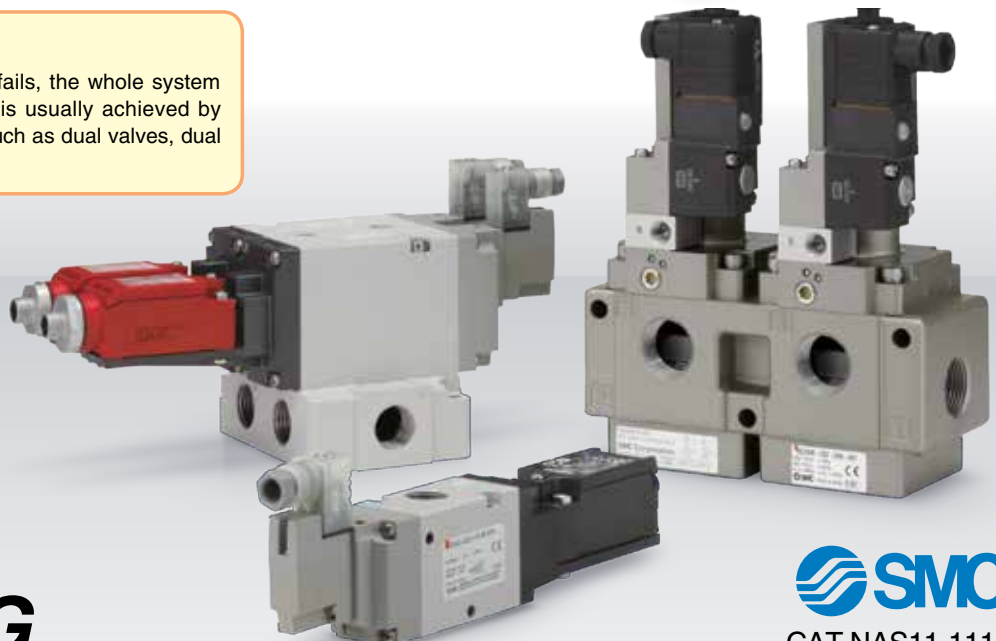

Series **VP/VG**

SMC
CAT.NAS11-111A

With Detection of Main Valve Position (Category 2)

Category 2 Safety function can be accomplished by single channel and is automatically checked.

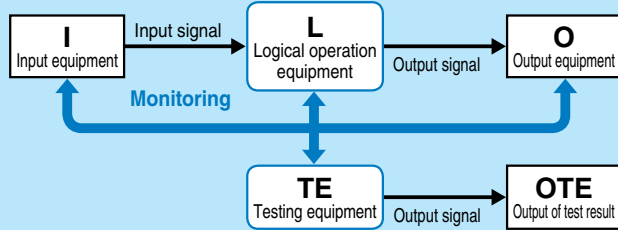

The detecting function of the main valve position detects a mismatch between the input signal and valve operation.

Input equipment (I): Detection equipment (sensor) of starting event
 Logical operation equipment (L): Relay sequence circuit, PLC control program
 Output equipment (O): Solenoid valve, Electromagnetic switch, Output relay
 Recommended valve: VP542/742-X536

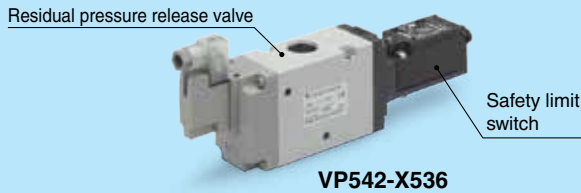

* This product is component which is a part of a safety system and safety equipment is not guaranteed by this single unit alone.

Redundant system can be constructed easily. (Category 3, 4)

Category 3 It has redundancy so there is no loss of safety function with a single failure.

The safety function must be checked before each use. An accumulation of undetected faults can cause loss of safety function.

Category 4 It has redundancy so there is no loss of safety function with a single failure. The safety function must be checked before each use. An accumulation of undetected faults does not affect the safety function. (Higher DC and MTTFd than Category 3.)

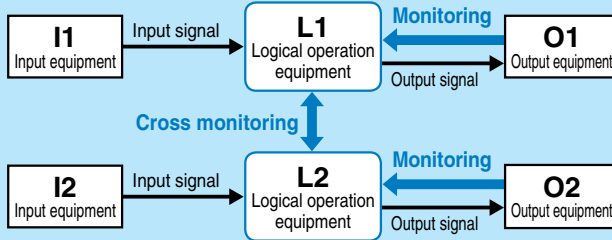

When the dual residual pressure release valve is used, if one of the valves fails to operate, the other one releases residual pressure.

Input equipment (I1, I2): Detection equipment (sensor) of starting event
 Logical operation equipment (L1, L2): Relay sequence circuit, PLC control program
 Output equipment (O1, O2): Solenoid valve, Electromagnetic switch, Output relay
 Recommended valve: VP544/744-X538, VG342-X87

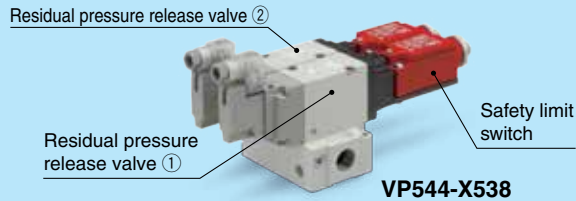

Highly reliable construction

① The main valve position is detected by transferring the main valve movement directly to the reed safety limit switch with the rod.

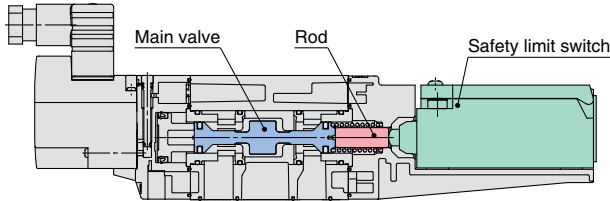

② Long service life: B10d: 10 million times*
 ③ The return spring releases the residual pressure securely regardless of pressure level.

* For VP500/700, safety limit switch made by OMRON

Safety limit switch can be selected.



Made by OMRON

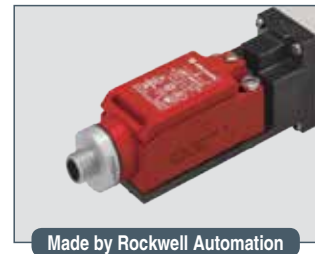

Made by Rockwell Automation

Conduit (VP series only) and M12 connector (4 pin) types are available.

M12 connector with 6 pins is available.

With soft start-up function (-X555)

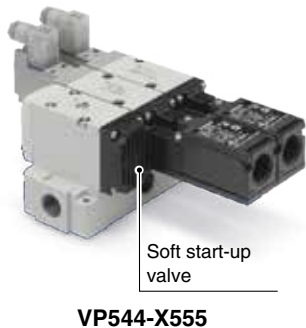

- A function to gradually increase the initial pressure of the pneumatic system has been added to the dual residual pressure release valve.
- Fixed orifice and variable throttle are available as a throttle for adjusting the pressure increase. (ø1, ø1.5, ø2)

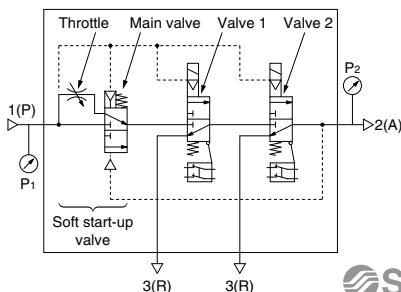

Output Pressure (P2) vs Time Graph

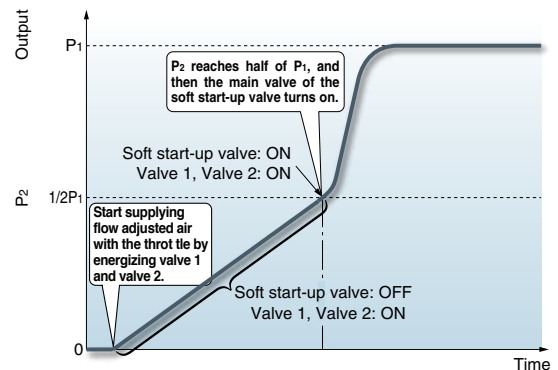







Standards and Enclosure

Series	Category	Safety limit switch manufacturer	Standards						Enclosure	
			Machinery Directive	2006/42/EC			CE	cUL		RoHS
				Harmonized standards	EN ISO13849-1: 2008 EN ISO13849-2: 2008	EN ISO4414: 2010				
Residual Pressure Release Valve VP542/742-X536 Page 3	2	OMRON Corporation		●	●		●	●	IP65	
		Rockwell Automation,					●	●		
Dual Residual Pressure Release Valve VP544/744-X538 Page 3	3, 4	OMRON Corporation		●	●		●	●	IP65	
		Rockwell Automation,					●	●		
Dual Residual Pressure Release Valve with Soft Start-up Function VP544/744-X555 Page 3	3, 4	OMRON Corporation					●	●	IP65	
		Rockwell Automation,					●	●		
Dual Residual Pressure Release Valve VG342-X87 Page 19	3, 4	OMRON Corporation		●			●	●*	IP40	
		Rockwell Automation,					●	●		

* Only port size 3/4"

Series Variations

Series	Category	Port size	Thread	Flow rate characteristics C [dm ³ /(s·bar)] 1→2 (P→A)				
				5	10	15	20	25
Residual Pressure Release Valve VP542-X536 	2	3/8"	Rc, G, NPT	8.9				
Residual Pressure Release Valve VP742-X536 		1/2"	Rc, G, NPT	15.1				
Dual Residual Pressure Release Valve VP544-X538 	3, 4	3/8"	Rc, G, NPT	6.5				
Dual Residual Pressure Release Valve VP744-X538 		1/2"	Rc, G, NPT	10.3				
Dual Residual Pressure Release Valve with Soft Start-up Function VP544-X555 		3/8"	Rc, G, NPT	5.2				
Dual Residual Pressure Release Valve with Soft Start-up Function VP744-X555 		1/2"	Rc, G, NPT	9.8				
Dual Residual Pressure Release Valve VG342-X87 		3/4"	Rc, G,	26.6				

Can be connected to Modular type F.R.L. units. Page 17

Applicable models*

- VP544/744-X538
- VP544/744-X555

* Please contact SMC for the VP542/742-X536.

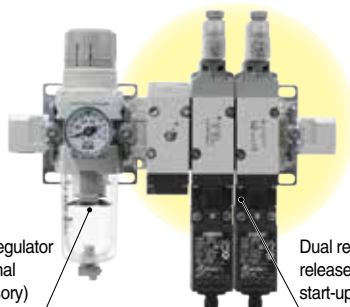

For details about Safety Standard ISO13849-1, refer to "Guide to Products Conforming to International Standards" on the SMC website.

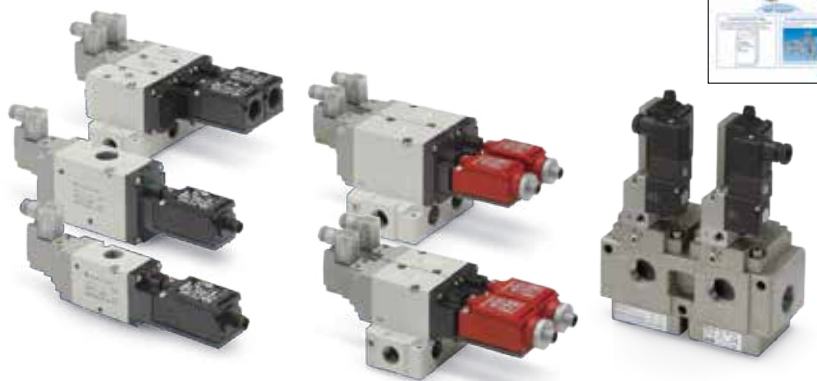

Valve Specifications

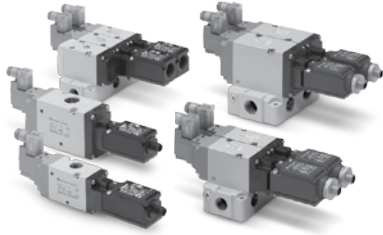

Fluid	Air	
Type of actuation	N.C. (Spring return)	
Operation	Internal pilot	External pilot
Operating pressure range	36 to 102 psi [0.25 to 0.7 MPa]	36 to 102 psi [0.25 to 0.7 MPa]
External pilot pressure	—	0.25 to 0.7 MPa (Same as operating pressure)
Maximum operating frequency	30 times/minute	
Minimum operating frequency	1 time/week	
Operating and ambient temperature	14 to 122°F [-10 to 50°C] (No freezing)	
Ambient humidity	20 to 90%RH (No condensation)	
Manual override	None	
Pilot exhaust	Individual exhaust	
Lubrication	Not required	
Mounting orientation	Unrestricted	
Impact/Vibration resistance	150/30 m/s ²	
Enclosure	IP65	
Operating environment	Indoors	
B10d (MTTFd calculation)	1000000 times (for the safety limit switch made by OMRON) 1000000 times (for the safety limit switch made by Rockwell Automation)	

Internal Pilot Type

⚠ Caution

Valve may not operate properly when air supply to P port is not adequate and the supply pressure to the valve is lower than 36 psi [0.25 MPa], the minimum operating pressure. Be careful with insufficient supply pressure.

Piping for External Pilot Type

⚠ Caution

The product may not operate when the external pilot pressure is insufficient due to simultaneous operation or restricted air piping. In this case, use the check valve (AKH series) with the external pilot port, change the piping size or adjust the set pressure to provide a constant pressure of 36 psi [0.25 MPa] or more.

Flow Rate Characteristics/Weight

Series	Flow rate characteristics						Weight [g]
	1→2 (P→A)			2→3 (A→R)			
	C [dm ³ /(s·bar)]	b	Cv	C [dm ³ /(s·bar)]	b	Cv	
VP542-X536	8.9	0.16	2.2	8.9	0.20	2.1	350
VP742-X536	15.1	0.21	3.6	15.3	0.22	3.7	590
VP544-X538	6.5	0.08	1.3	6.7	0.10	1.3	930
VP744-X538	10.3	0.08	2.3	9.7	0.08	2.1	1510
VP544-X555	5.2	0.06	1.1	6.7	0.10	1.3	1105
VP744-X555	9.8	0.08	2.1	9.7	0.08	2.1	2000

Needle Valve/Flow Rate Characteristics (VP544/744-X555)

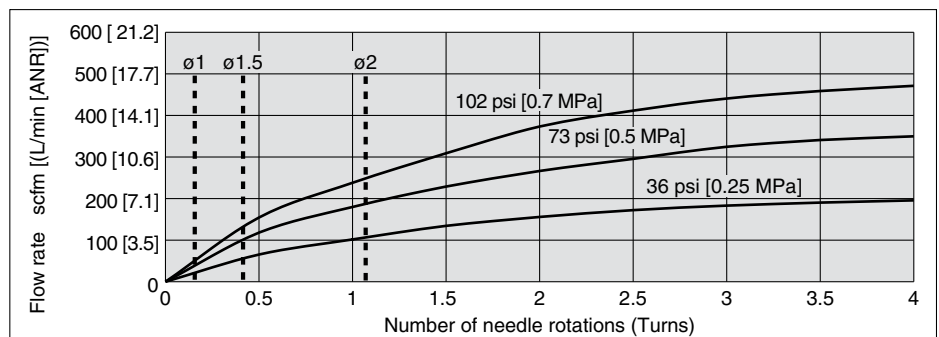

Solenoid Specifications

Electrical entry	DIN terminal
Rated voltage	24 VDC
Allowable voltage fluctuation	±10%
Power consumption	0.45 W
Surge voltage suppressor	Varistor
Indicator	LED

Safety Limit Switch Specifications

Manufacturer	OMRON	Rockwell Automation
Electrical wiring	G1/2, M12 connector	M12 connector
Contact resistance	25 mΩ or less	50 mΩ or less
Min. applicable load	5 VDC, 1 mA (Load resistance)	5 VDC, 5 mA (Load resistance)
Max. voltage	24 VDC	
Max. load current	50 mA	
Max. load inductance	0.5 H	
Insulation voltage	300 V	600 V
Protection against electric shock	Class II (EN60947-5-1: 2004)	

VP500/700-X536, X538, X555

Symbols

Safety limit switch
Made by
OMRON

Symbol

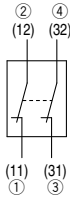

Terminal/Pin Numbers (Built-in switch 2N.C.)

M12 connector pin number	Wiring specification	G1/2 terminal number	Wiring specification
①		(11)	
②		(12)	
③		(31)	
④		(32)	

VP542(R)/742(R)-X536

Internal pilot

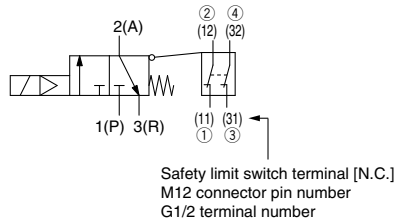

External pilot

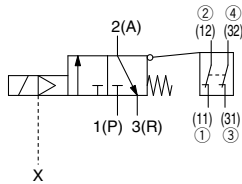

External pilot/With check valve

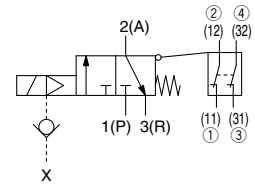

VP544(R)/744(R)-X538

Internal pilot

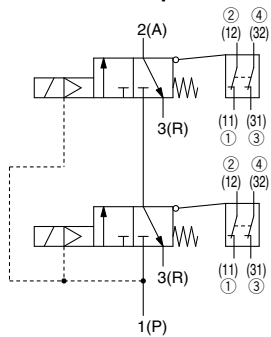

External pilot

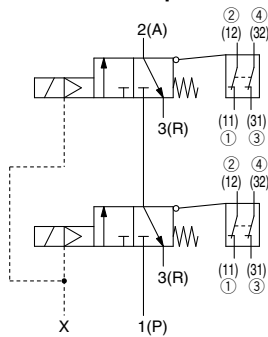

External pilot/With check valve

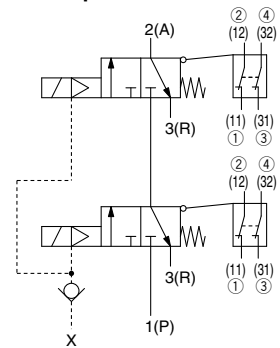

VP544(R)/744(R)-X555

Internal pilot

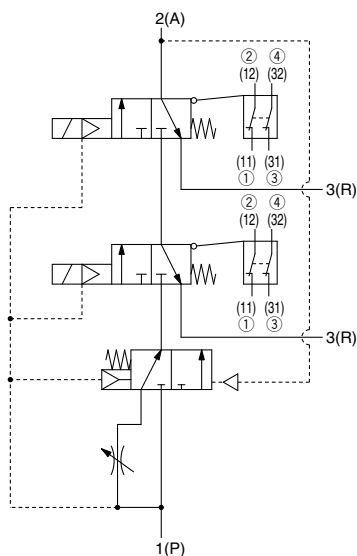

External pilot

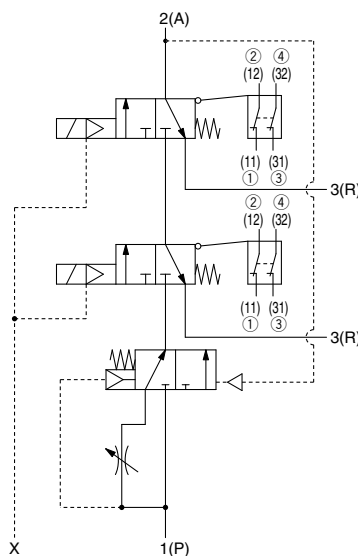

External pilot/With check valve

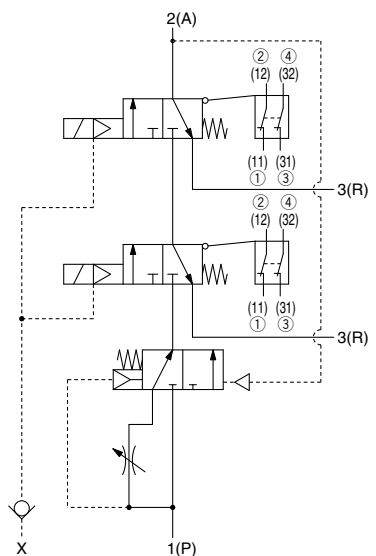

Symbols

Safety limit switch
Made by
Rockwell Automation

Symbol

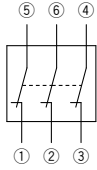

Pin Numbers (Built-in switch 3N.C.)

M12 connector pin number	Wiring specification
①	
⑤	
②	
⑥	
③	
④	

VP542(R)/742(R)-X536

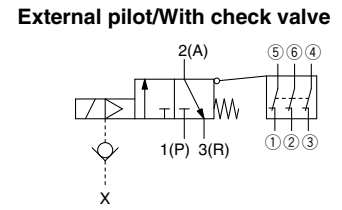
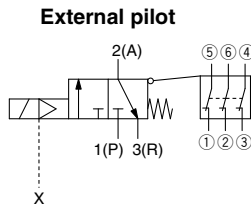
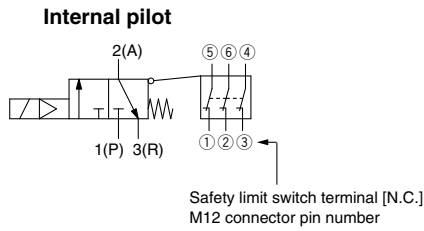

VP544(R)/744(R)-X538

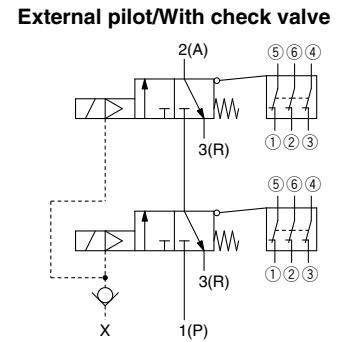
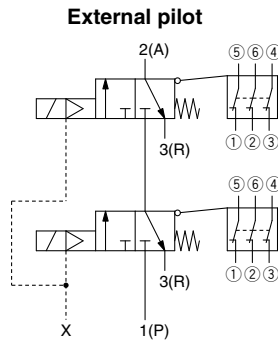
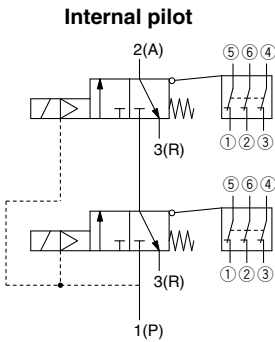

VP544(R)/744(R)-X555

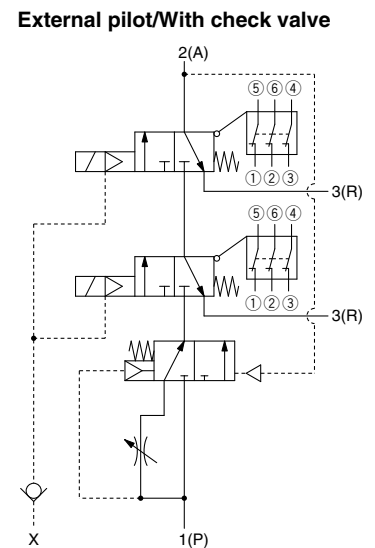
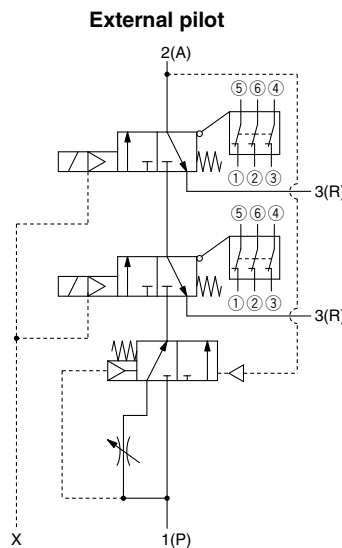
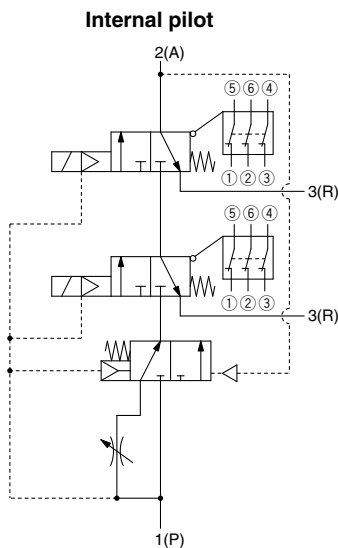

VP500/700-X536

Dimensions

Residual Pressure Release Valve (-X536)

VP542(R)-5^DZ1-03□-□-X536

VP542(R)-5^DZ1-03□-M□-X536

Safety limit switch

Made by
OMRON

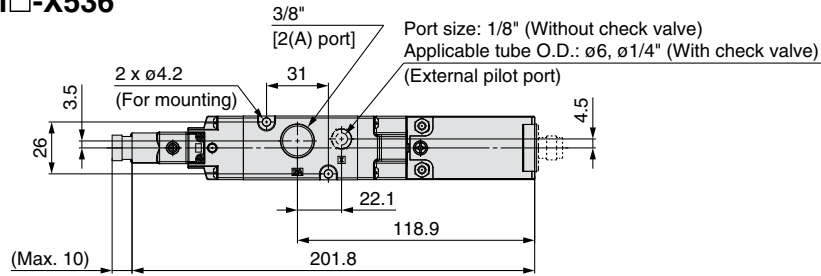

Applicable cable O.D.
ø3.5 to ø7

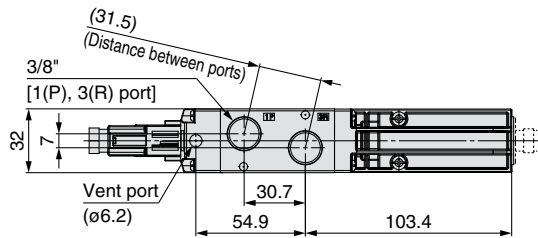
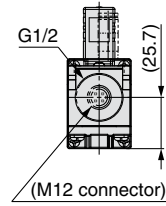
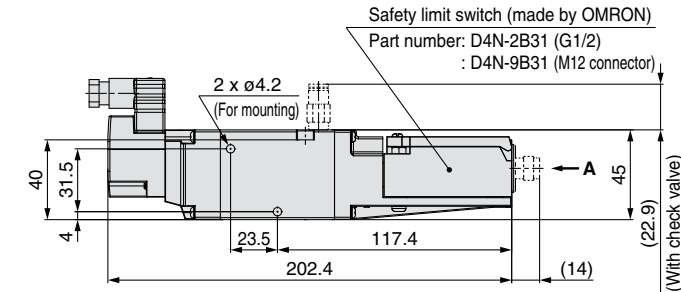
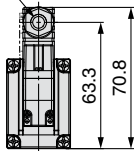

View A
For M12 connector

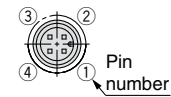

VP542(R)-5^DZ1-03□-S1□-X536

Safety limit switch

Made by
Rockwell Automation

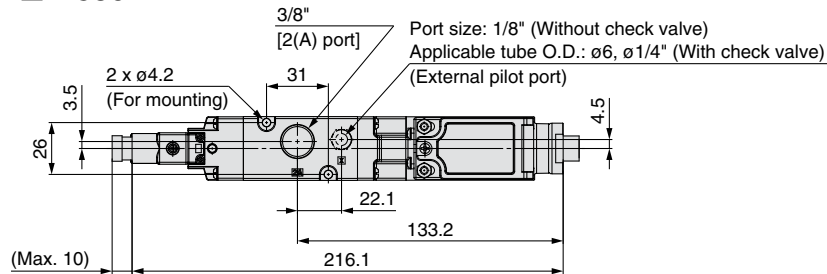

Applicable cable O.D.
ø3.5 to ø7

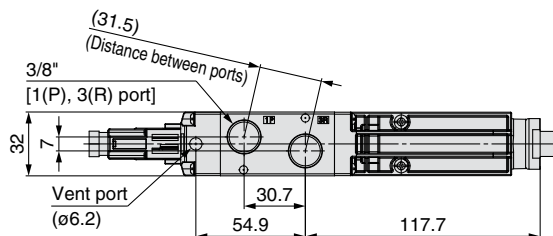
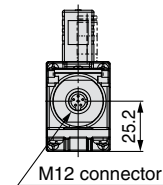
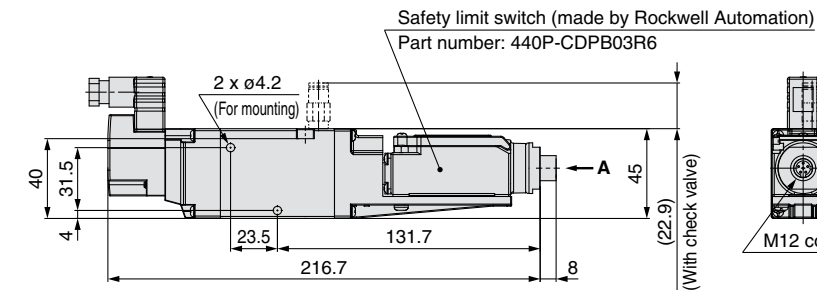
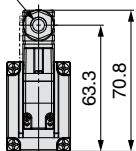

View A
M12 connector

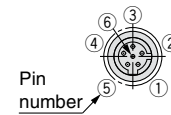

Dimensions

Residual Pressure Release Valve (-X536)

VP742(R)-5^DZ1-04□-□-X536

VP742(R)-5^DZ1-04□-M□-X536

Safety limit switch

Made by
OMRON

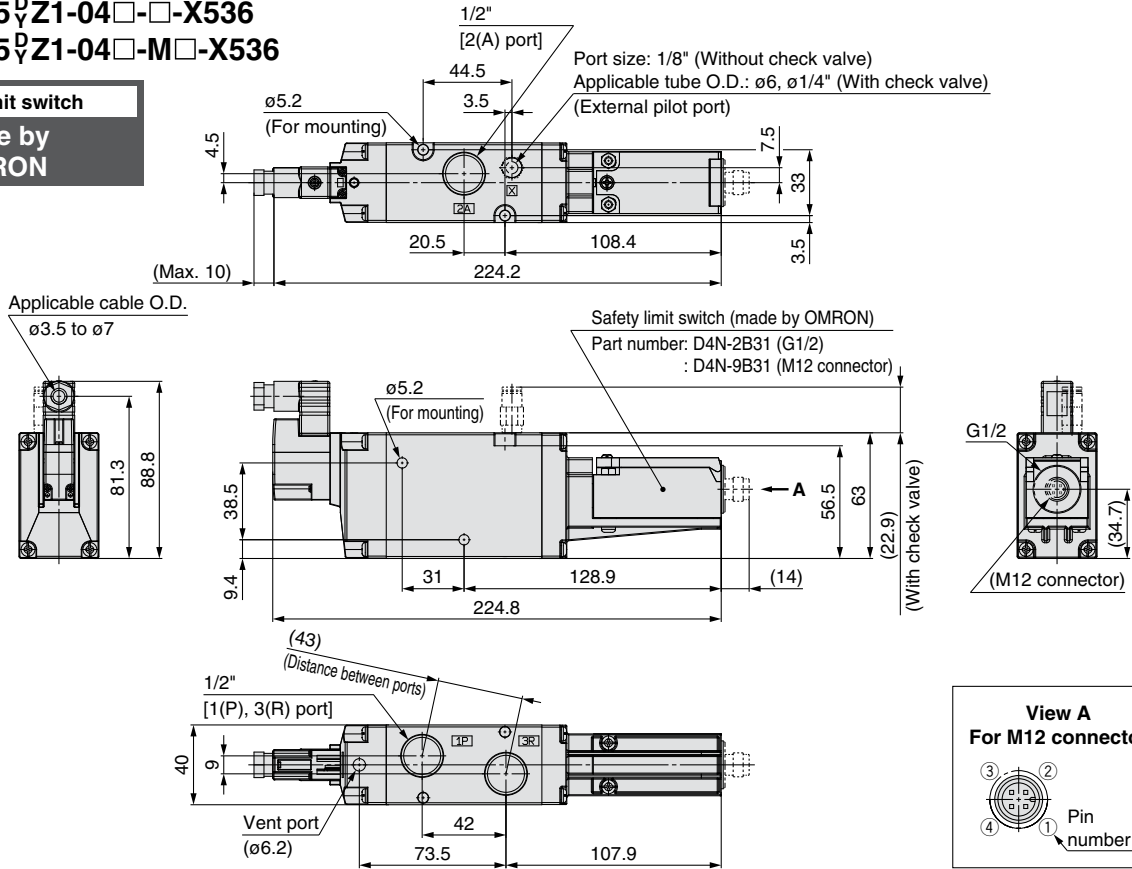

VP742(R)-5^DZ1-04□-S1□-X536

Safety limit switch

Made by
Rockwell Automation

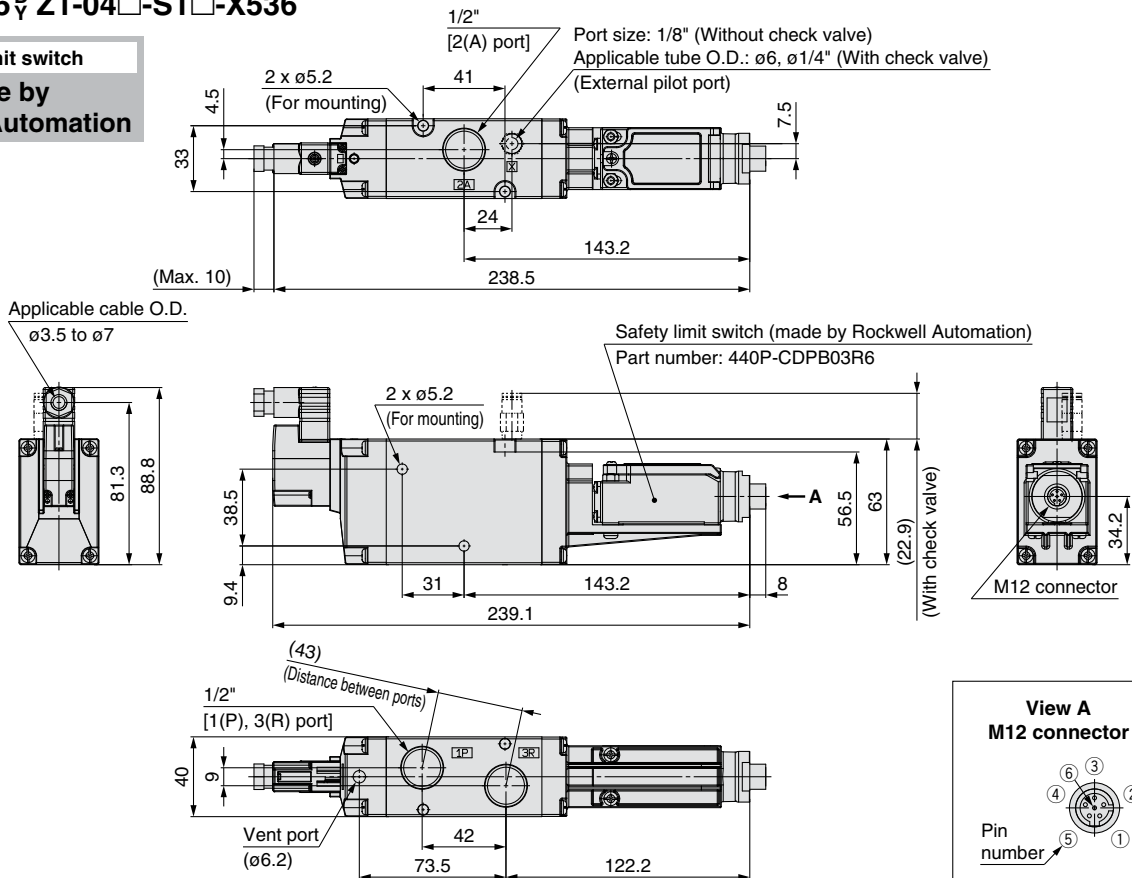

VP500/700

Symbols

X536

X538

X555

Optional Accessories

Specific Product Precautions

VG342

Symbols

X87

Specific Product Precautions

VP500/700-X538

Dimensions

Dual Residual Pressure Release Valve (-X538)

VP544(R)-5^DZ1-03□-□-X538

VP544(R)-5^DZ1-03□-M□-X538

Safety limit switch
Made by
OMRON

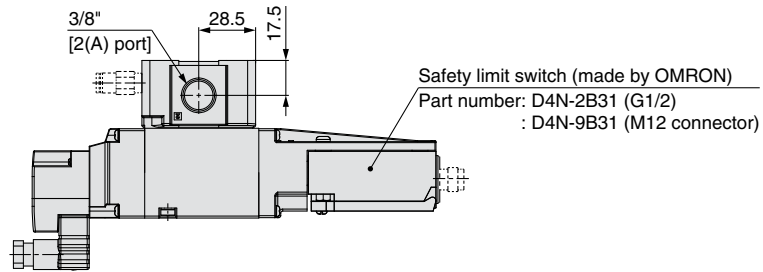

Port size: 1/8" (Without check valve)
Applicable tube O.D.: $\phi 6$, $\phi 1/4$ " (With check valve)
(External pilot port)

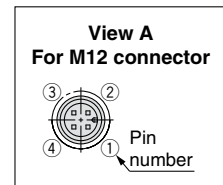
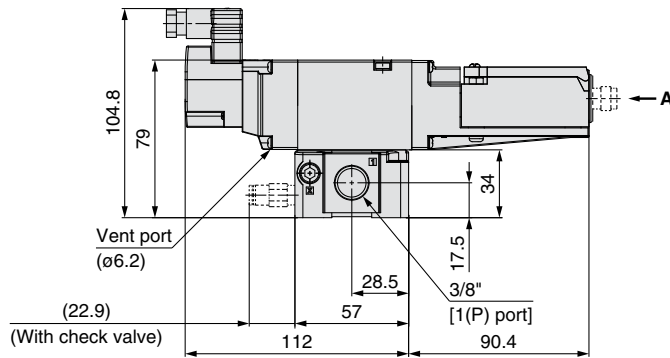
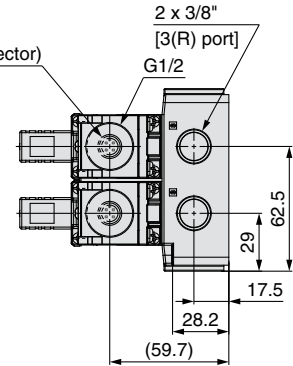
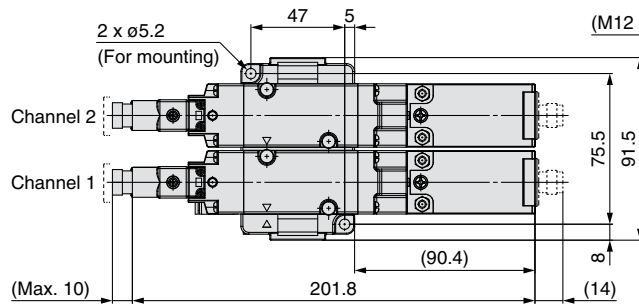
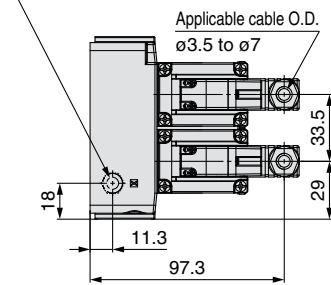

Dimensions

Dual Residual Pressure Release Valve (-X538)

VP544(R)-5^DZ1-03□-S1□-X538

Safety limit switch
**Made by
 Rockwell Automation**

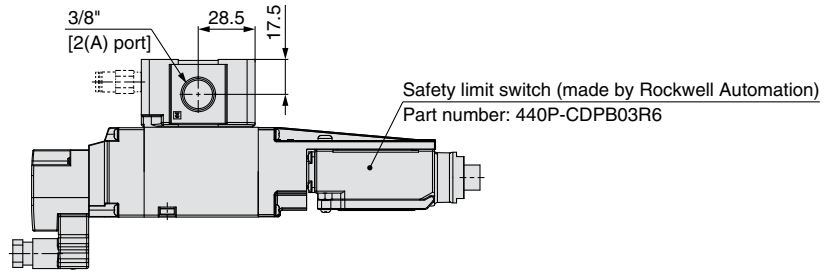

Port size: 1/8" (Without check valve)
 Applicable tube O.D.: $\phi 6$, $\phi 1/4$ " (With check valve)
 (External pilot port)

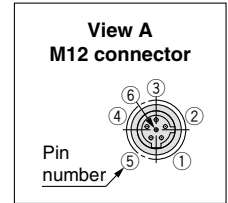
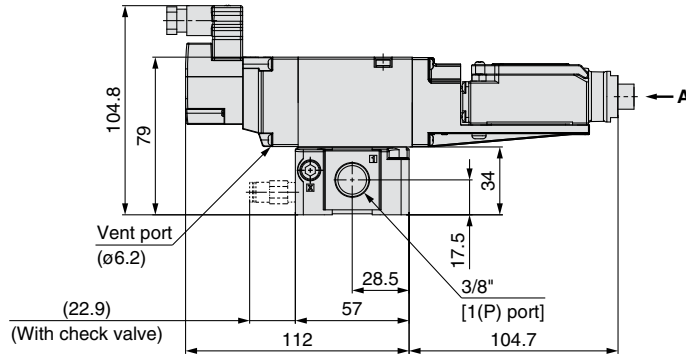
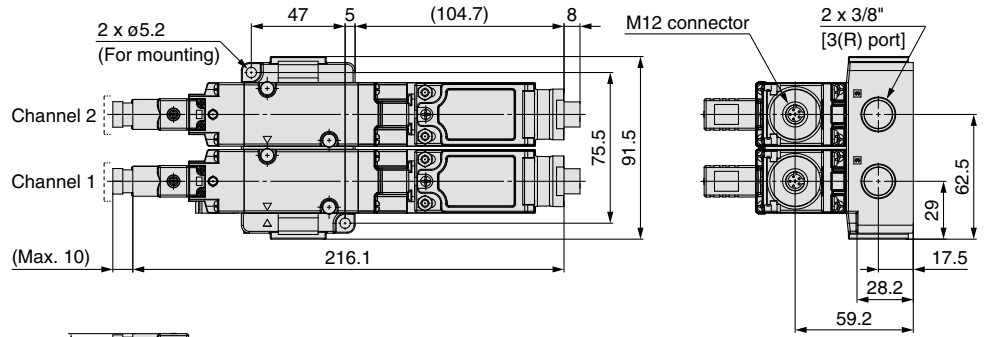
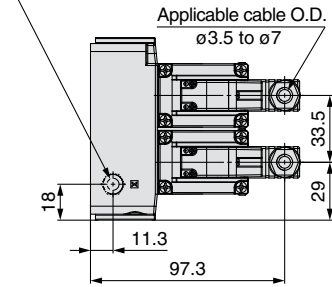

VP500/700

Symbols

X536

X538

X555

Optional Accessories

Specific Product Precautions

VG342

Symbols

X87

Specific Product Precautions

VP500/700-X538

Dimensions

Dual Residual Pressure Release Valve (-X538)

VP744(R)-5 $\frac{D}{P}$ Z1-04□-□-X538

VP744(R)-5 $\frac{D}{P}$ Z1-04□-M□-X538

Safety limit switch
Made by
OMRON

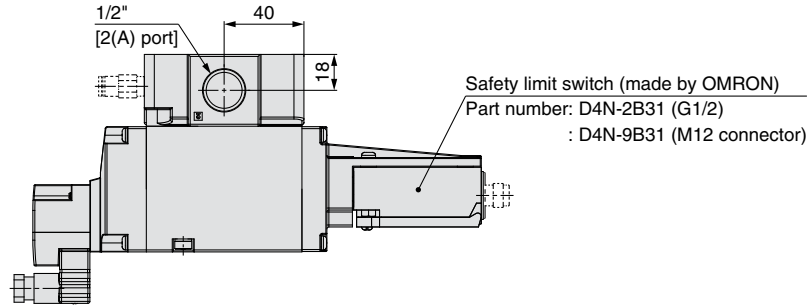

Port size: 1/8" (Without check valve)
Applicable tube O.D.: $\phi 6$, $\phi 1/4$ " (With check valve)
(External pilot port)

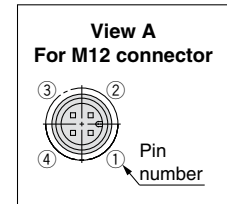
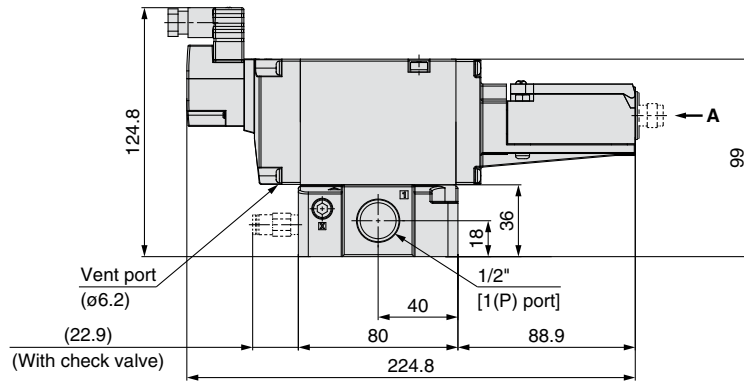
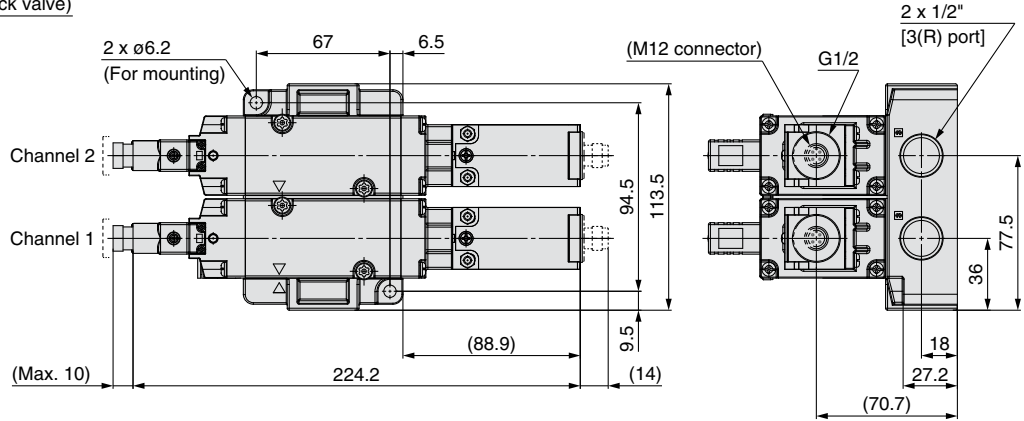
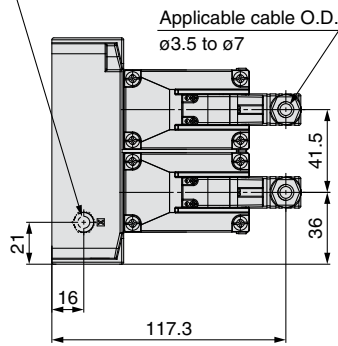

Dimensions

Dual Residual Pressure Release Valve (-X538)

VP744(R)-5^DZ1-04□-S1□-X538

Safety limit switch
 Made by
Rockwell Automation

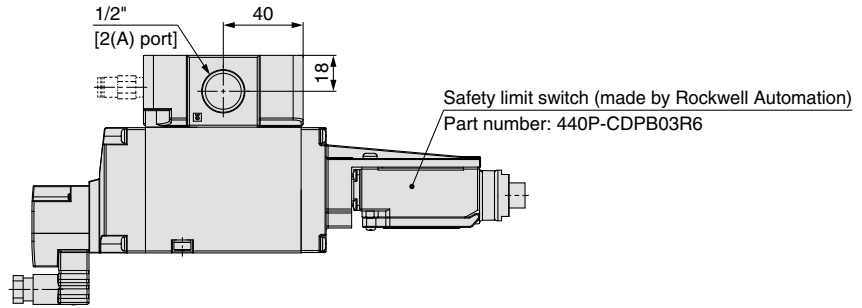

Port size: 1/8" (Without check valve)
 Applicable tube O.D.: ø6, ø1/4" (With check valve)
 (External pilot port)

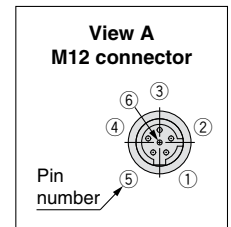
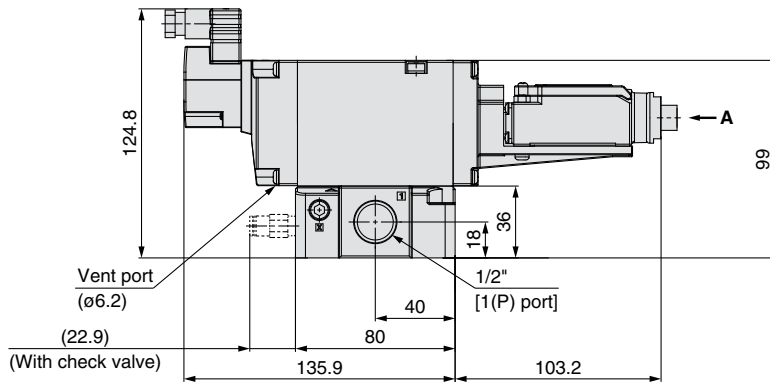
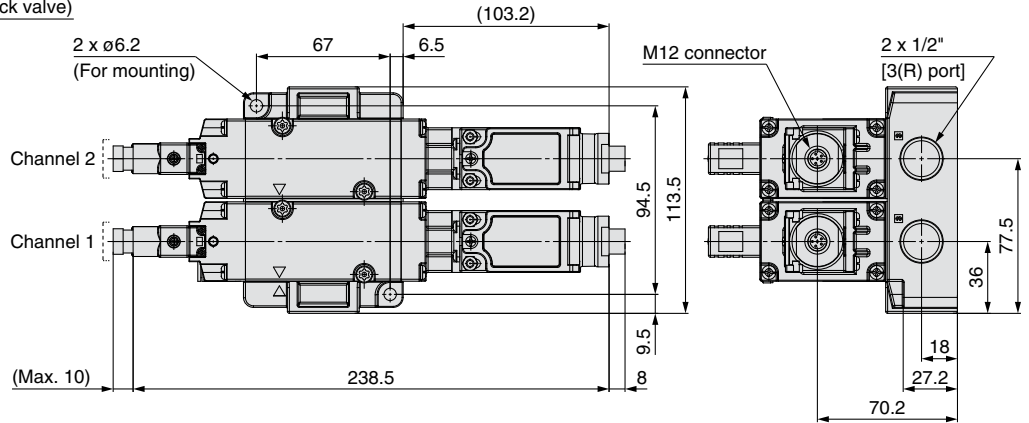
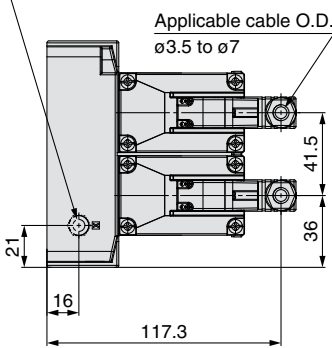

VP500/700

Symbols

X536

X538

X555

Optional Accessories

Specific Product Precautions

VG342

Symbols

X87

Specific Product Precautions

VP500/700-X555

Dimensions

Dual Residual Pressure Release Valve with Soft Start-up Function (-X555)

VP544(R)-5^DZ1-03□-□□-X555

VP544(R)-5^DZ1-03□-M□□-X555

Safety limit switch
Made by
OMRON

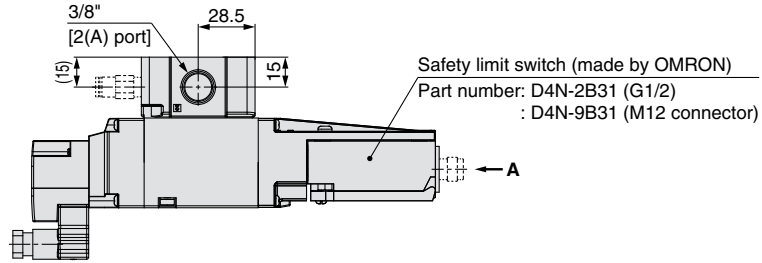

Port size: 1/8" (Without check valve)
 Applicable tube O.D.: ø6, ø1/4" (With check valve)
 (External pilot port)

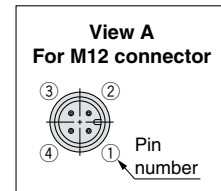
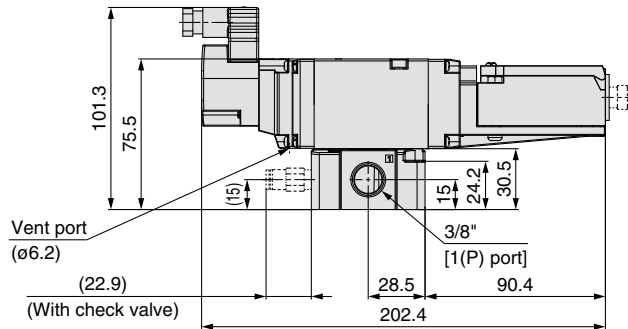
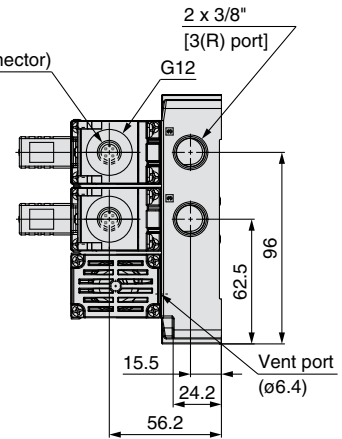
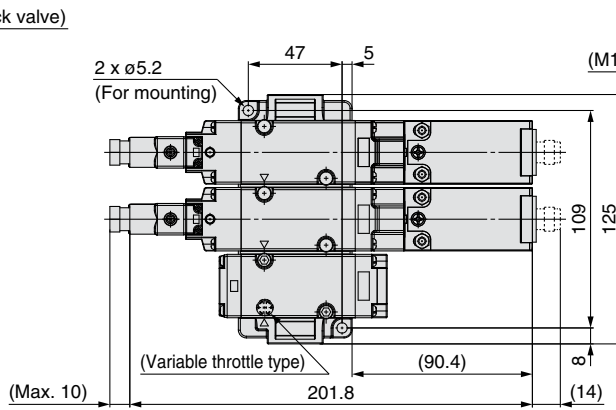
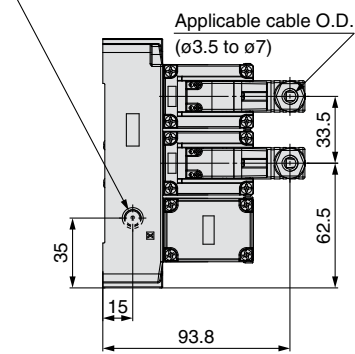

VP500/700-X538, X555 Optional Accessories

For details about optional accessories, refer to the **WEB catalog**.

Piping Adapter: 3/8, 1/2

A piping adapter allows installation/removal of the component without removing the piping and thus makes maintenance easier.

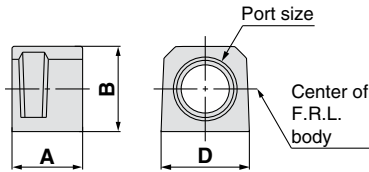

Part no. (Note)	Port size	A	B	D
E300-□03-A	3/8	31.8	30	30
E400-□04-A	1/2	31.8	36	36

Note) □ in part numbers indicates a pipe thread type. No indication is necessary for Rc; however, indicate N for NPT, and F for G.

* Separate interfaces are required for modular unit.

Spacer with Bracket

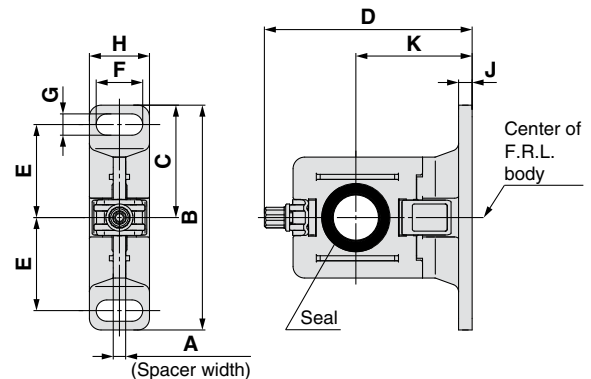

Part no.	A	B	C	D	E	F	G	H	J	K
Y300T-A	4.2	82	41	71.5	35	14	7	19	4	41
Y400T-A	5.2	96	48	86.1	40	18	9	26	5	50

Ordering Example*

VP544-5DZ1-03-X538 1 pc.
Filter regulator
AW30-03G-A 1 pc.
Spacer with bracket
Y300T-A 3 pcs.
Piping adapter
E300-03-A 2 pcs.

Dual residual pressure release valve with soft start-up function

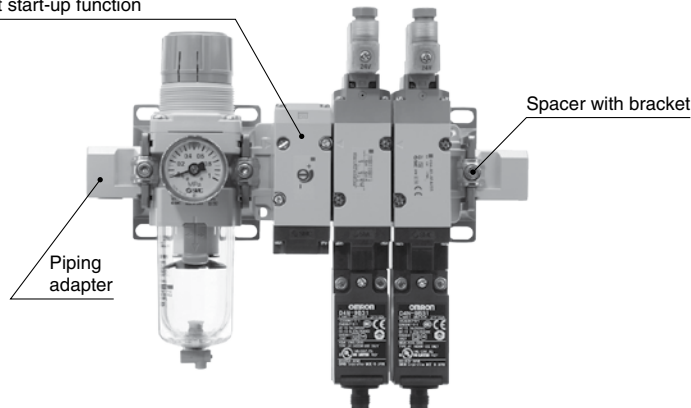

* Each product is not assembled.

Spacer with Bracket Mounting Position

Dual residual pressure release valve (-X538)

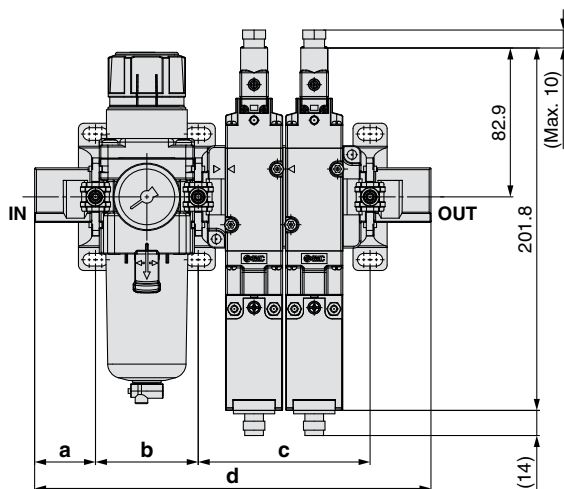

Model	a	b	c	d	Note
VP544-5DZ1-03-X538	33.9	57.2	95.7	220.7	AW30-03G-A Y300T-A E300-03-A
VP744-5DZ1-04-X538	34.4	75.2	118.7	262.7	AW40-04G-A Y400T-A E400-04-A

Dual residual pressure release valve with soft start-up function (-X555)

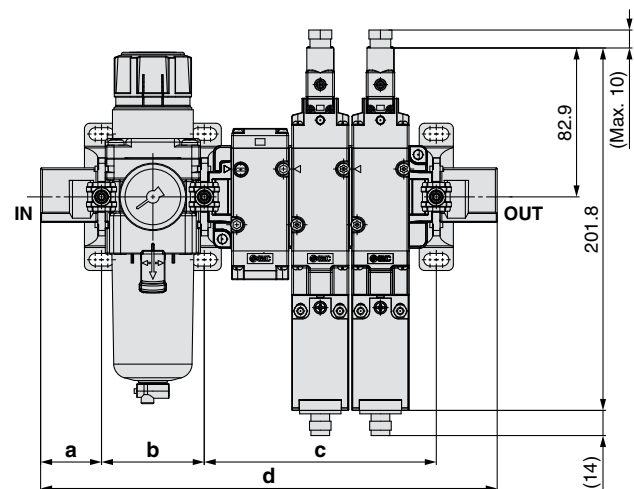

Model	a	b	c	d	Note
VP544-5DZ1-03-X555	33.9	57.2	129.2	254.2	AW30-03G-A Y300T-A E300-03-A
VP744-5DZ1-04-X555	34.4	75.2	160.2	304.2	AW40-04G-A Y400T-A E400-04-A



VP500/700-X536, X538, X555

Specific Product Precautions

Be sure to read this before handling. Refer to the back cover for Safety Instructions. For 3/4/5 Port Solenoid Valve Precautions, refer to "Handling Precautions for SMC Products" and the Operation Manual on the SMC website, <http://www.smcworld.com>

How to Use DIN Terminal Connector

⚠ Caution

Connection

1. Loosen the holding screw and pull the connector out of the solenoid valve terminal block.
2. After removing the holding screw, insert a flat blade screwdriver etc. into the notch on the bottom of the terminal block and pry it open, separating the terminal block and the housing.
3. Loosen the screw (slotted screws) in the terminal block. Insert the lead core wires to the terminals according to the connection method, and secure the wires by re-tightening the terminal screw.
4. Secure the cord by fastening the ground nut.

⚠ Caution

When making connections, please note that using other than the supported size ($\phi 3.5$ to $\phi 7$) heavy-duty cord will not satisfy IP65 (enclosure) standards. Also, be sure to tighten the ground nut and holding screw within their specified torque ranges.

Changing the entry direction

After separating the terminal block and housing, the cord entry can be changed by attaching the housing in the desired direction (4 directions at 90° intervals).

* When equipped with a light, be careful not to damage the light with the cord's lead wires.

Precautions

Plug in and pull out the connector vertically without tilting to one side.

Compatible cable

Cord O.D.: $\phi 3.5$ to $\phi 7$

(Reference) 0.5 mm², 2-core or 3-core, equivalent to JIS C 3306

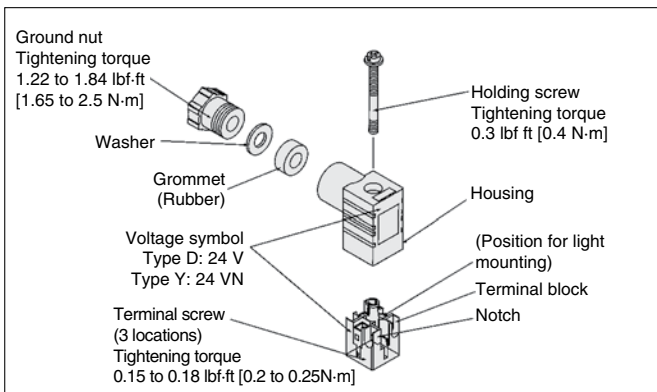

Type "Y"

DIN connector type Y is a DIN connector that conforms to the DIN pitch 8-mm standard.

- D type DIN connector with 9.4 mm pitch between terminals is not interchangeable.
- To distinguish from the D type DIN connector, "N" is listed at the end of voltage symbol.
- Dimensions are completely the same as D type DIN connector.

Light/Surge Voltage Suppressor

DIN Terminal

With light (DZ)
(YZ)

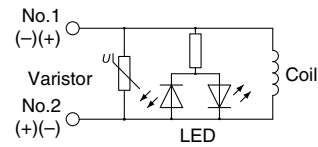

Note) Surge voltage suppressor of varistor has residual voltage corresponding to the protective element and rated voltage; therefore, protect the controller side from the surge voltage.

Limit Switch Cable

OMRON or Rockwell Automation M12 connector limit switch cable is available.

M12 Connector Cable (4 Pins) Made by OMRON

Part number	Cable length [mm]
ZS-37-L	300
ZS-37-M	500
ZS-37-N	1000
ZS-37-P	2000
ZS-37-C	5000

M12 Connector Cable (6 Pins) Made by Rockwell Automation

Part number	Cable length [mm]
VP500-231-1	2000

Installation

Use the external pilot type when using VP500/700-X536 or X538 with AV series. Install the AV series to the primary side.

VP500/700

Symbols

X536

X538

X555

Optional Accessories

Specific Product Precautions

VG342

Symbols

X87

Specific Product Precautions

3 Port Solenoid Valve/Residual Pressure Release Valve with Detection of Main Valve Position

VG342-X87

How to Order

Dual residual pressure release valve

VG342 **R** - 5 **DZ** - 06 **□** - **M** **□** - X87

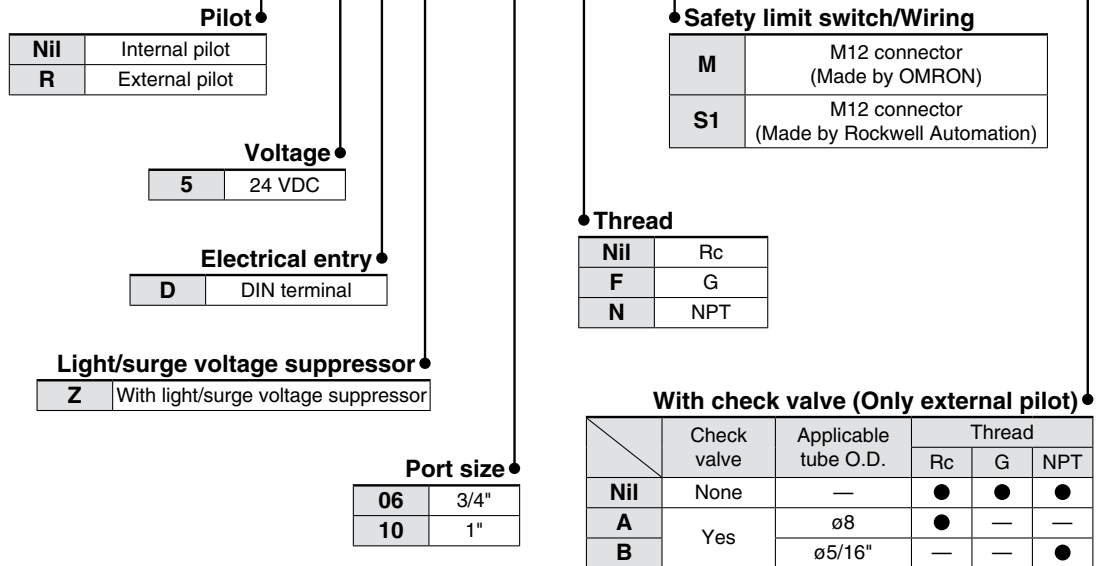

* For internal pilot, the symbol is nil.
 * Refer to "Piping for External Pilot Type" on page 20 for selection of the check valve.

Made to Order

1 Series Compatible with Secondary Batteries

For details about 25A-, refer to the WEB catalog "Series Compatible with Secondary Batteries/Series 25A-."

How to Order

25A-VG342 **□** - 5 **DZ** - **□** **□** - **M** **□** - X87

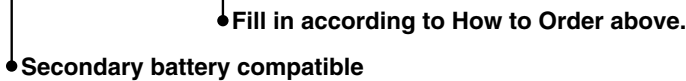

Note) Electrical entry can be selected only for D type.
 Check valve type is available only when the thread type is Rc.

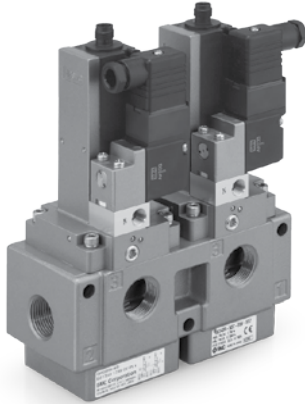

Valve Specifications

Fluid	Air	
Type of actuation	N.C. (Spring return)	
Operation	Internal pilot	External pilot
Operating pressure range	36 to 102 psi [0.25 to 0.7 MPa]	36 to 102 psi [0.25 to 0.7 MPa]
External pilot pressure	—	36 to 102 psi [0.25 to 0.7 MPa] (Same as operating pressure)
Maximum operating frequency	30 times/minute	
Minimum operating frequency	1 time/week	
Operating and ambient temperature	14 to 122 °F [-10 to 50°C] (No freezing)	
Ambient humidity	95%RH or less (No condensation)	
Manual override	None	
Pilot exhaust	Individual exhaust	
Lubrication	Not required	
Mounting orientation	Unrestricted	
Impact/Vibration resistance	150/50 m/s ²	
Enclosure	IP40	
Operating environment	Indoors	
Weight	2.8 kg	2.9 kg
B10d (MTTFd calculation)	900000 times	

Internal Pilot Type

⚠ Caution

Valve may not operate properly when air supply to P port is not adequate and the supply pressure to the valve is lower than 36 psi [0.25 MPa], the minimum operating pressure. Be careful with insufficient supply pressure.

Piping for External Pilot Type

⚠ Caution

The product may not operate when the external pilot pressure is insufficient due to simultaneous operation or restricted air piping. In this case, use the check valve (AKH series) with the external pilot port, change the piping size or adjust the set pressure to provide a constant pressure of 36 psi [0.25 MPa] or more.

Flow Rate Characteristics

Series	Flow rate characteristics					
	1→2 (P→A)			2→3 (A→R)		
	C [dm ³ /(s·bar)]	b	Cv	C [dm ³ /(s·bar)]	b	Cv
VG342-X87	26.6	0.04	5.5	28.6	0.03	5.6

Solenoid Specifications

Electrical entry	DIN terminal
Rated voltage	24 VDC
Allowable voltage fluctuation	-15% to +10% of rated voltage
Power consumption	2.2 W
Suppressor	Diode
Indicator	LED

Safety Limit Switch Specifications

Manufacturer	OMRON	Rockwell Automation
Electrical wiring	M12 connector	
Contact resistance	25 mΩ or less	50 mΩ or less
Min. applicable load	5 VDC, 1 mA (Load resistance)	5 VDC, 5 mA (Load resistance)
Max. voltage	24 VDC	
Max. load current	50 mA	
Max. load inductance	0.5 H	
Insulation voltage	300 V	600 V
Protection against electric shock	Class II (EN60947-5-1: 2004)	

VP500/700

Symbols

X536

X538

X555

Optional Accessories

Specific Product Precautions

VG342

Symbols

X87

Specific Product Precautions

VG342-X87

Symbols

Safety limit switch
Made by
OMRON

Symbol

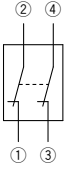

Pin Numbers (Built-in switch 2N.C.)

M12 connector pin number	Wiring specification
①	
②	
③	
④	

VG342(R)-X87

Internal pilot

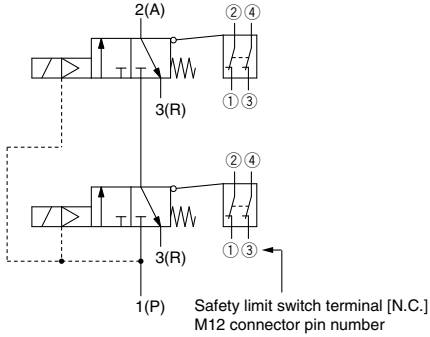

External pilot

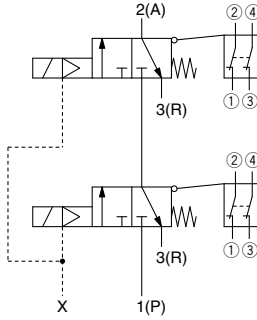

External pilot/With check valve

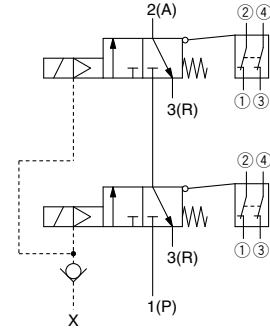

Safety limit switch
Made by
Rockwell Automation

Symbol

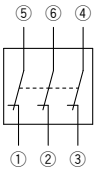

Pin Numbers (Built-in switch 3N.C.)

M12 connector pin number	Wiring specification
①	
⑤	
②	
⑥	
③	
④	

VG342(R)-X87

Internal pilot

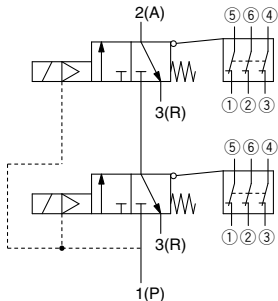

External pilot

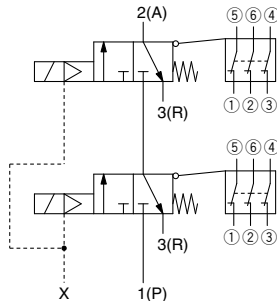

External pilot/With check valve

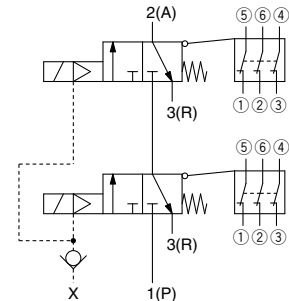

VG342-X87

Dimensions

Dual Residual Pressure Release Valve (-X87)

VG342(R)-5DZ-10□-M□-X87

Safety limit switch
Made by
OMRON

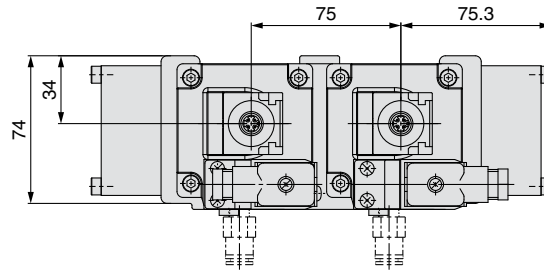

Port size: 1/8" (Without check valve)
Applicable tube O.D.: $\phi 8$, $\phi 5/16$ " (With check valve)
(External pilot port)

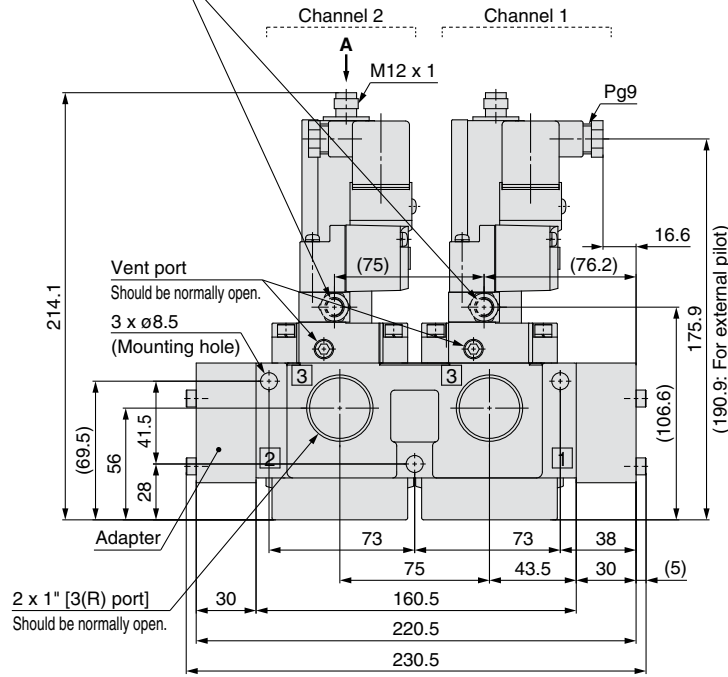
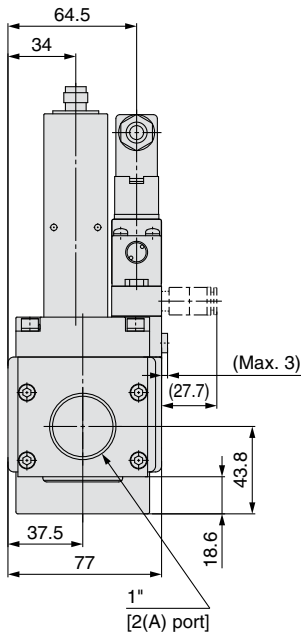

Safety limit switch (made by OMRON)
Part number: D4N-9B31
Applicable cable O.D.
 $\phi 4.5$ to $\phi 7$

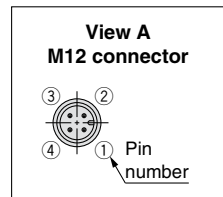
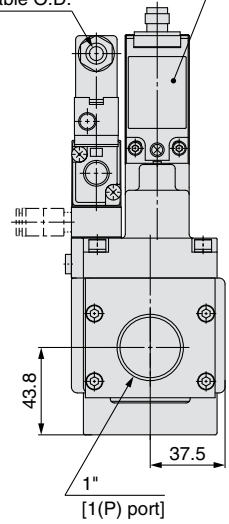

Dimensions

Dual Residual Pressure Release Valve (-X87)

VG342(R)-5DZ-06□-S1□-X87

Safety limit switch
Made by
Rockwell Automation

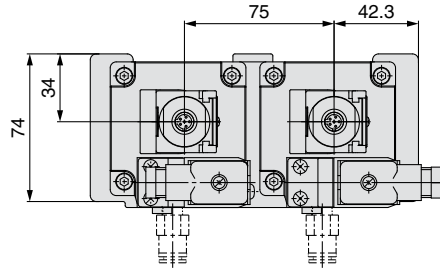

Port size: 1/8" (Without check valve)
Applicable tube O.D.: ø8, ø5/16" (With check valve)
(External pilot port)

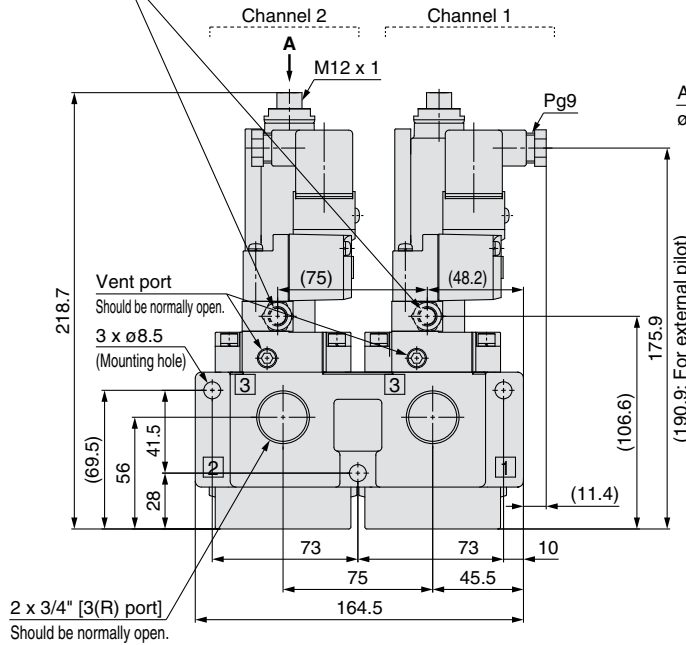
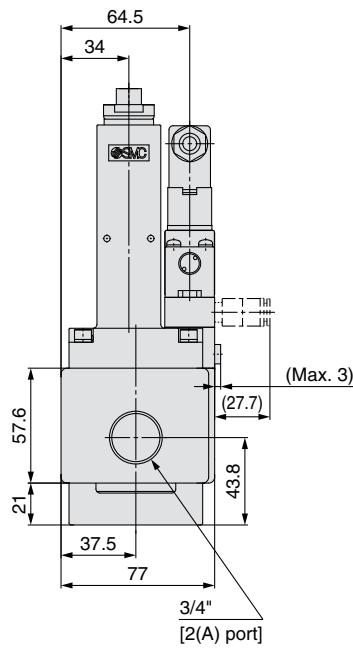

Safety limit switch
(made by Rockwell Automation)
Part number: 440P-CDPB03R6
Applicable cable O.D.
ø4.5 to ø7

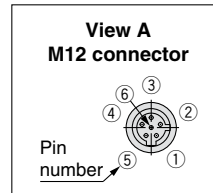
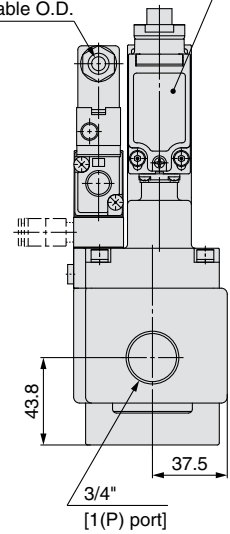

VP500/700
Symbols
X536
X538
X555
Optional Accessories
Specific Product Precautions

VG342
Symbols
X87
Specific Product Precautions

VG342-X87

Dimensions

Dual Residual Pressure Release Valve (-X87)

VG342(R)-5DZ-10□-S1□-X87

Safety limit switch
Made by
Rockwell Automation

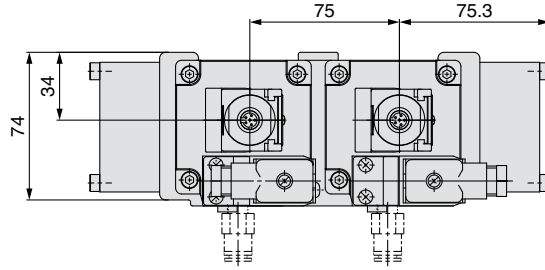

Port size: 1/8" (Without check valve)
Applicable tube O.D.: ø8, ø5/16" (With check valve)
(External pilot port)

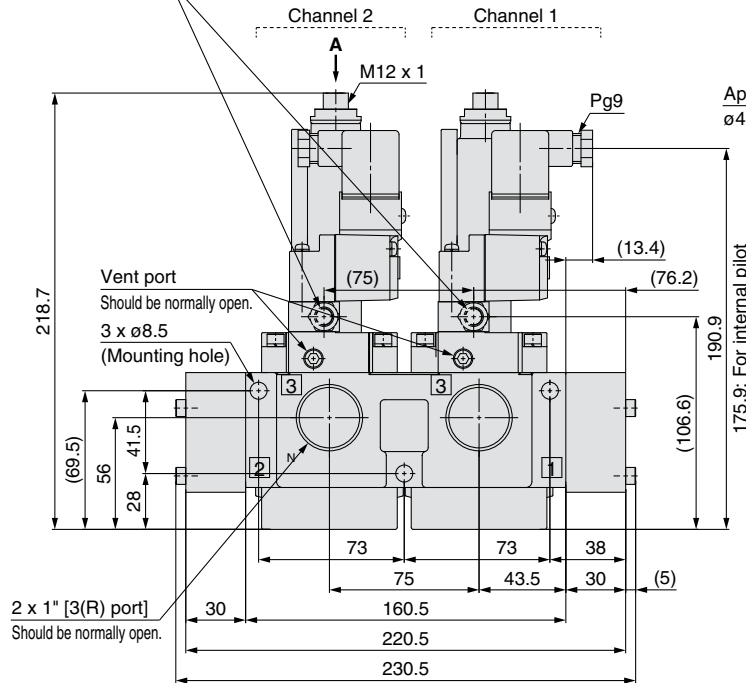
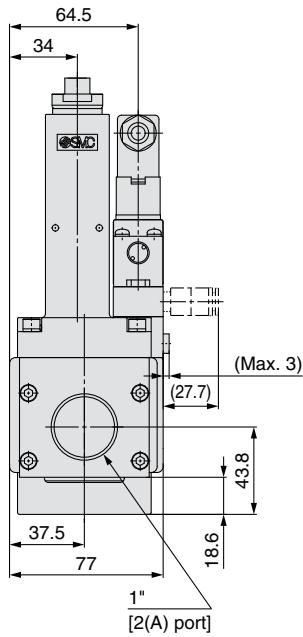

Safety limit switch
(made by Rockwell Automation)
Part number: 440P-CDPB03R6
Applicable cable O.D.
ø4.5 to ø7

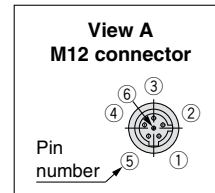
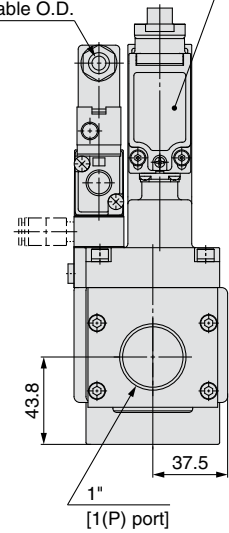

VG342-X87

Specific Product Precautions

Be sure to read this before handling. Refer to the back cover for Safety Instructions. For 3/4/5 Port Solenoid Valve Precautions, refer to "Handling Precautions for SMC Products" and the Operation Manual on the SMC website, <http://www.smcworld.com>



How to Use DIN Terminal Connector

⚠ Caution

Connection

- Loosen the holding screw and pull the connector out of the solenoid valve terminal block.
- After removing the holding screw, insert a flat blade screwdriver etc. into the notch on the bottom of the terminal block and pry it open, separating the terminal block and the housing.
- Loosen the screw in the terminal block. Insert the lead core wires to the terminals, and secure the wires by re-tightening the terminal screw.
As the product has polarity, referring to the electric circuit diagram, wire the product correctly as per the symbol of the terminal No. of the terminal block.
- Secure the cord by fastening the ground nut.
Tighten the ground nut and holding screw within the specified range of torque.

Changing the entry direction

After separating the terminal block and housing, the cord entry can be changed by attaching the housing in the opposite direction 180°.

* Be careful not to damage the element etc. with the cord's lead wires.

Precautions

Plug in and pull out the connector vertically without tilting to one side.

Compatible cable

Cord O.D.: $\varnothing 4.5$ to $\varnothing 7$ (Reference) 0.5 to 1.5 mm², 2-core or 3-core, equivalent to JIS C 3306

Applicable crimped terminals

O-terminals: Equivalent to R1.25-4M defined in the JIS C 2805

Y-terminals: Equivalent to 1.25-3L made by J.S.T. Mfg. Co., Ltd.

Rod-terminals: Up to size 1.5

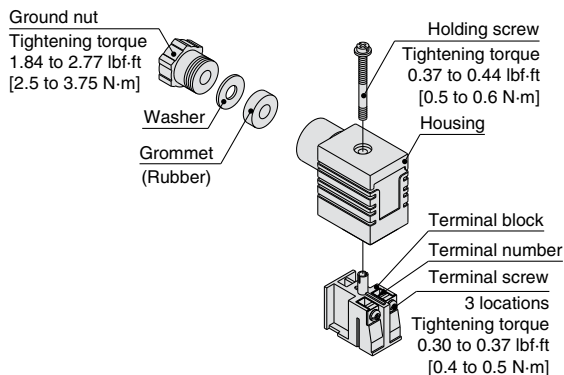

Light/Surge Voltage Suppressor

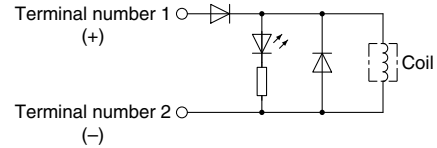

Limit Switch Cable

OMRON or Rockwell Automation M12 connector limit switch cable is available.

M12 Connector Cable (4 Pins) Made by OMRON

Part number	Cable length [mm]
ZS-37-L	300
ZS-37-M	500
ZS-37-N	1000
ZS-37-P	2000
ZS-37-C	5000

M12 Connector Cable (6 Pins) Made by Rockwell Automation

Part number	Cable length [mm]
VP500-231-1	2000

VP500/700

Symbols

X536

X538

X555

Optional Accessories

Specific Product Precautions

VG342

Symbols

X87

Specific Product Precautions

Safety Instructions

These safety instructions are intended to prevent hazardous situations and/or equipment damage. These instructions indicate the level of potential hazard with the labels of “Caution,” “Warning” or “Danger.” They are all important notes for safety and must be followed in addition to International Standards (ISO/IEC)*1, and other safety regulations.

 **Caution:** Caution indicates a hazard with a low level of risk which, if not avoided, could result in minor or moderate injury.

 **Warning:** Warning indicates a hazard with a medium level of risk which, if not avoided, could result in death or serious injury.

 **Danger:** Danger indicates a hazard with a high level of risk which, if not avoided, will result in death or serious injury.

*1) ISO 4414: Pneumatic fluid power – General rules relating to systems.
ISO 4413: Hydraulic fluid power – General rules relating to systems.
IEC 60204-1: Safety of machinery – Electrical equipment of machines.
(Part 1: General requirements)
ISO 10218-1: Manipulating industrial robots – Safety.
etc.

Warning

1. The compatibility of the product is the responsibility of the person who designs the equipment or decides its specifications.

Since the product specified here is used under various operating conditions, its compatibility with specific equipment must be decided by the person who designs the equipment or decides its specifications based on necessary analysis and test results. The expected performance and safety assurance of the equipment will be the responsibility of the person who has determined its compatibility with the product. This person should also continuously review all specifications of the product referring to its latest catalog information, with a view to giving due consideration to any possibility of equipment failure when configuring the equipment.

2. Only personnel with appropriate training should operate machinery and equipment.

The product specified here may become unsafe if handled incorrectly. The assembly, operation and maintenance of machines or equipment including our products must be performed by an operator who is appropriately trained and experienced.

3. Do not service or attempt to remove product and machinery/equipment until safety is confirmed.

1. The inspection and maintenance of machinery/equipment should only be performed after measures to prevent falling or runaway of the driven objects have been confirmed.
2. When the product is to be removed, confirm that the safety measures as mentioned above are implemented and the power from any appropriate source is cut, and read and understand the specific product precautions of all relevant products carefully.
3. Before machinery/equipment is restarted, take measures to prevent unexpected operation and malfunction.

4. Contact SMC beforehand and take special consideration of safety measures if the product is to be used in any of the following conditions.

1. Conditions and environments outside of the given specifications, or use outdoors or in a place exposed to direct sunlight.
2. Installation on equipment in conjunction with atomic energy, railways, air navigation, space, shipping, vehicles, military, medical treatment, combustion and recreation, or equipment in contact with food and beverages, emergency stop circuits, clutch and brake circuits in press applications, safety equipment or other applications unsuitable for the standard specifications described in the product catalog.
3. An application which could have negative effects on people, property, or animals requiring special safety analysis.
4. Use in an interlock circuit, which requires the provision of double interlock for possible failure by using a mechanical protective function, and periodical checks to confirm proper operation.

Caution

1. The product is provided for use in manufacturing industries.

The product herein described is basically provided for peaceful use in manufacturing industries.
If considering using the product in other industries, consult SMC beforehand and exchange specifications or a contract if necessary.
If anything is unclear, contact your nearest sales branch.

Limited warranty and Disclaimer/ Compliance Requirements

The product used is subject to the following “Limited warranty and Disclaimer” and “Compliance Requirements”.

Read and accept them before using the product.

Limited warranty and Disclaimer

1. The warranty period of the product is 1 year in service or 1.5 years after the product is delivered, whichever is first.*2)
Also, the product may have specified durability, running distance or replacement parts. Please consult your nearest sales branch.
2. For any failure or damage reported within the warranty period which is clearly our responsibility, a replacement product or necessary parts will be provided.
This limited warranty applies only to our product independently, and not to any other damage incurred due to the failure of the product.
3. Prior to using SMC products, please read and understand the warranty terms and disclaimers noted in the specified catalog for the particular products.

*2) Vacuum pads are excluded from this 1 year warranty.

A vacuum pad is a consumable part, so it is warranted for a year after it is delivered.
Also, even within the warranty period, the wear of a product due to the use of the vacuum pad or failure due to the deterioration of rubber material are not covered by the limited warranty.

Compliance Requirements

1. The use of SMC products with production equipment for the manufacture of weapons of mass destruction (WMD) or any other weapon is strictly prohibited.
2. The exports of SMC products or technology from one country to another are governed by the relevant security laws and regulations of the countries involved in the transaction. Prior to the shipment of a SMC product to another country, assure that all local rules governing that export are known and followed.

Caution

SMC products are not intended for use as instruments for legal metrology.

Measurement instruments that SMC manufactures or sells have not been qualified by type approval tests relevant to the metrology (measurement) laws of each country. Therefore, SMC products cannot be used for business or certification ordained by the metrology (measurement) laws of each country.

 **Safety Instructions** Be sure to read the “Handling Precautions for SMC Products” (M-E03-3) and “Operation Manual” before use.

SMC Corporation of America
10100 SMC Blvd., Noblesville, IN 46060
www.smcusa.com

SMC Pneumatics (Canada) Ltd.
www.smc Pneumatics.ca

(800) SMC.SMC1 (762-7621)
e-mail: sales@smcusa.com
International inquiries: www.smcworld.com

