

Air Pilot Operated Series NVSA

3105, 4014/402/3/44

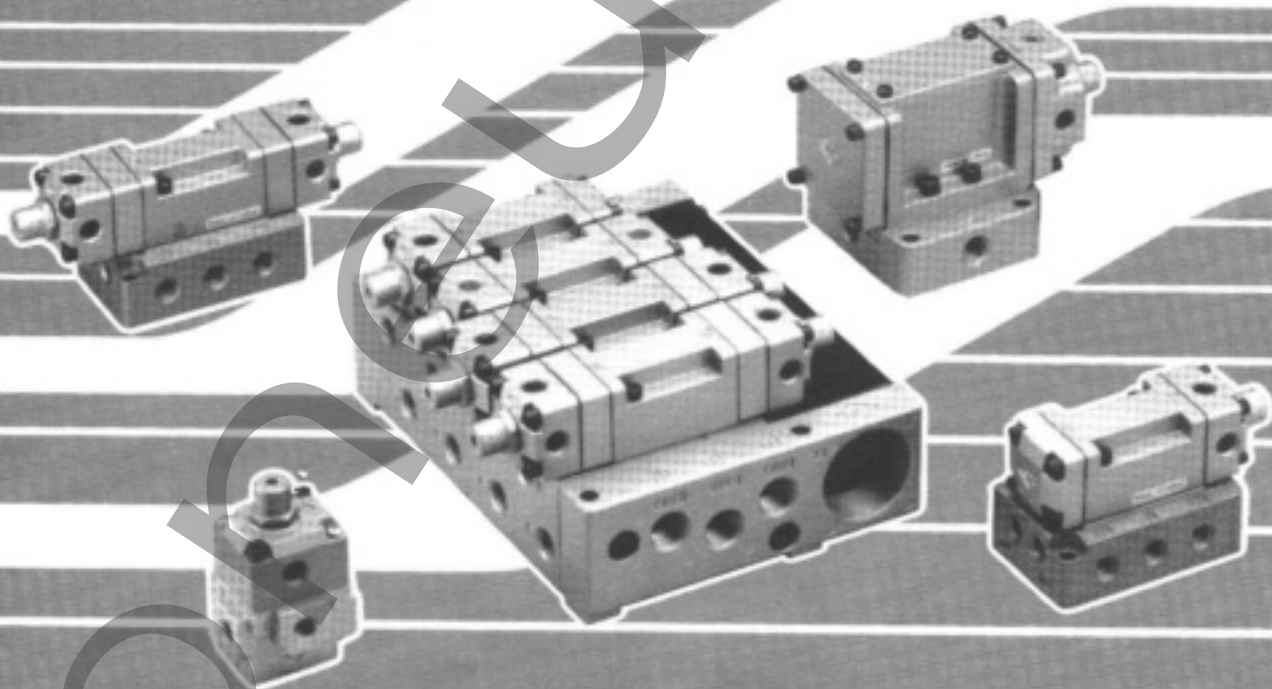

Contents	Page
NVSA 3 Way Valves	2-7
NVSA 4 Way/5 Port (Class 1 type)	8-14
NVSA 4 Way/5 Port (Class 2-4 type)	15-24

**DESIGN**

This design concept consists of a Match-Ground "SPOOL & SLEEVE" assembly which controls the main valving functions. This match-ground fit creates an "Air Bearing" effect for extended and efficient operation and eliminates the need for resilient seals. Large capacity air flows are achieved by application of the SMC U.S. Patents applicable to this type of valve. Should the valve require disassembly for maintenance the Spool and Sleeve should be retained as a unit.

GENERAL:

These valves are compact, heavy duty matched ground spool and sleeve air valves intended for general industrial service.

HOW THE VALVE WORKS:

The spring holds the spool fully up. When pilot pressure is introduced into the "A" pilot chamber, this pressure acts on the end of the spool, and forces it down. When this pressure becomes high enough, it forces the spool down and compresses the spring. When the pilot chamber is exhausted, the pressure against the spool decays, and the spring returns the spool to the up position.

PILOT IDENTIFICATION:

The official standard for diagramming air logic is National Fluid Power Association Recommended Standard T3.28.9-1973 "Method of Diagramming for Moving Part Fluid Controls." The entire standard is built around the identification of the spring end of the valve as the "B" end and the end opposite the spring as the "A" end. The valve body carries this identification and conforms with the NFPA standard.

PILOT-PRESSURE CHARACTERISTICS:

The spool has no seals, and is balanced to air pressures. Thus the pressure in the valve has no effect on the pilot pressure required to shift the spool. The pilot pressure required is always constant, regardless of the pressure in the main passages.

This feature makes the valve an ideal companion for air logic systems, assuring constant response from cycle to cycle. No other type of valve action provides this constant response.

The standard output pressure for moving part air logic is 50 PSIG (3.44 Bar). The 25 PSIG pilot pressure required to shift this valve gives approximately the same response to shift and to return when the pilot pressure applied is 50 PSIG (3.44 Bar). The minimum volume of the pilot chamber and the small swept volume displaced by the short-stroke spool also aid in fast response.

MULTI-PURPOSE FLOW PATTERN:

True multi-purpose valve. Any port may be pressurized, back-pressurized, or plugged without affecting the operation of the spool. May be used without modification as a normally open or normally closed 3-way or 2-way, simply by piping and plugging the appropriate ports. May also be piped as a selector or a diverter.

MOUNTING:

Intended for foot mounting or is light enough to hang in a pipe line. Pipe taps are directly in the body. Valve may be mounted in any position.

SERIES
NVSA 3115, 3125
NVSA 3135, 3145

DIRECTIONAL AIR VALVE
AIR PILOT OPERATED

SPECIFICATIONS

CHARACTERISTICS		NVSA 3115	NVSA 3125	NVSA 3135	NVSA 3145
C_v Rating	1/8" NPTF	0.80	0.69	—	—
	1/4" NPTF	1.10	0.83	—	—
	3/8" NPTF	—	—	2.58	—
	1/2" NPTF	—	—	2.58	4.17
	3/4" NPTF	—	—	—	4.50
Spool Stroke In (mm)		0.126 (3.2)	0.177 (4.5)	0.197 (5.0)	0.386 (9.8)
Pilot Pressures* PSIG (Kg/cm ²)					
1. To start spool shifting		12 (0.8)	12 (0.8)	5 (0.3)	5 (0.3)
2. To shift spool fully		25 (1.7)	25 (1.7)	10 (0.7)	10 (0.7)
3. Maximum Permissible		100 (6.7)	125 (8.3)	125 (8.3)	125 (8.3)
Media:	Air (lubricated or oil-free), any non-flammable, non-toxic, non-corrosive gasses except oxygen.				
Leakage:	Port to port (internal) not to exceed 0.030 cubic feet per minute at 100 PSIG (6.7 Kg/cm ²).				
Operating Pressures:	28" Vacuum to 300 PSIG (20 Kg/cm ²)				
Materials:	All housing parts aluminum die castings. Spool and sleeve 440F stainless steel, heat treated to 58-62 Rockwell C, and passivated. Sleeve O-rings Buna N. Spacer and spring seat Delrin. Bumper urethane rubber.				
Maximum ambient temperature:	140°F. (60° C.)				
*Note: These pilot pressures apply only to clean, well lubricated valves.					

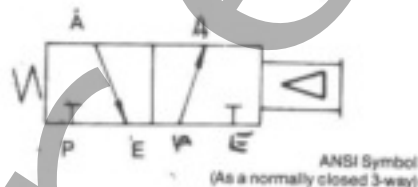

MULTI-PURPOSE APPLICATIONS

FOR USE AS:	PORT "A"	PORT "P"	PORT "E"
2-Way Normally Closed	Outlet	Supply	Plug
2-Way Normally Open	Outlet	Plug	Supply
3-Way Normally Closed	Outlet	Supply	Exhaust
3-Way Normally Open	Outlet	Exhaust	Supply
Diverter	Supply	Outlet	Outlet
Two-pressure selector	Outlet	Supply 1	Supply 2

HOW TO ORDER

This model number is a coded number which describes all available options.

NVSA 3 1 1 5 - 01 N

Valve Size

- 1 = Class 1
- 2 = Class 2
- 3 = Class 3
- 4 = Class 4

Mounting Style

- 4 = Valve unit only (NVSA3114 only; see page 7)
- 5 = Foot mounting; pipe tap in body

Porting

- 00 = Manifold mounting (NVSA 3114)
- 01 = 1/8" NPTF (VSA 3115, 3125)
- 02 = 1/4" NPTF (NVSA 3115, 3125)
- 03 = 3/8" NPTF (NVSA 3135)
- 04 = 1/2" NPTF (NVSA 3135, 3145)
- 06 = 3/4" NPTF (NVSA 3145)

Optional Features

- N = with Recessed non-locking operator
- O = without Manual operator

NVSA 3135, 3145 only

- H = Internal pilot connection in junction box, recessed non-locking operator
- S = Internal pilot connection in junction box, no operator

NVSA 3115

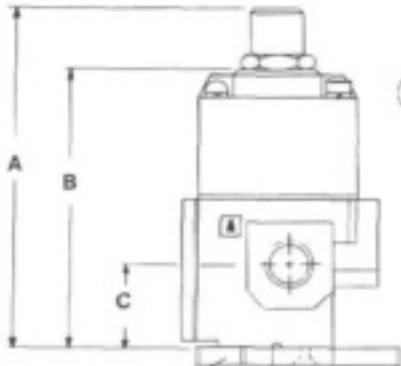
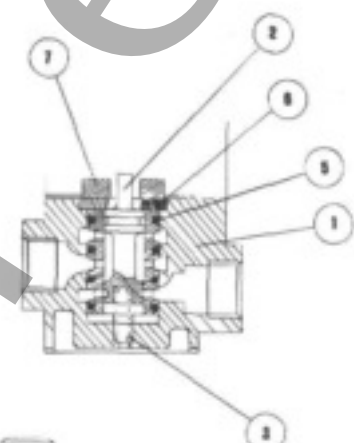
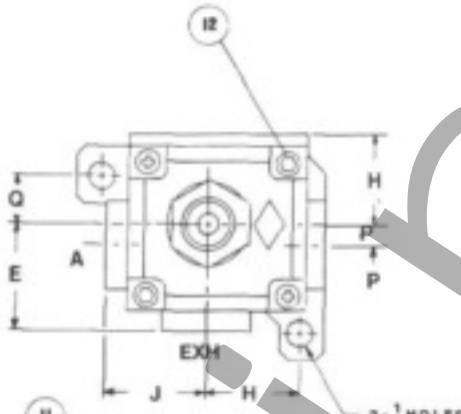
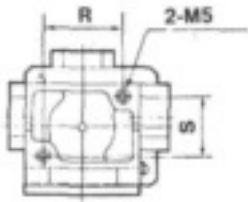

OPTIONAL!
MTG. BASE AXT 338-11

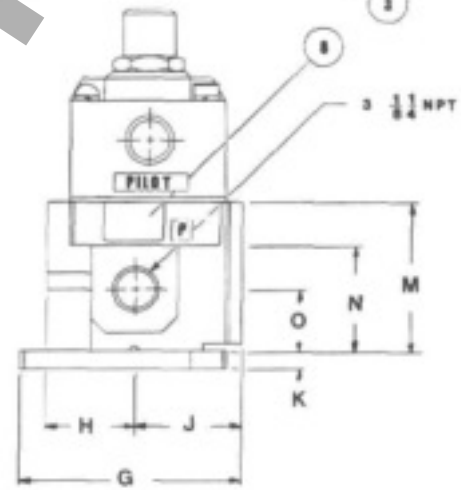
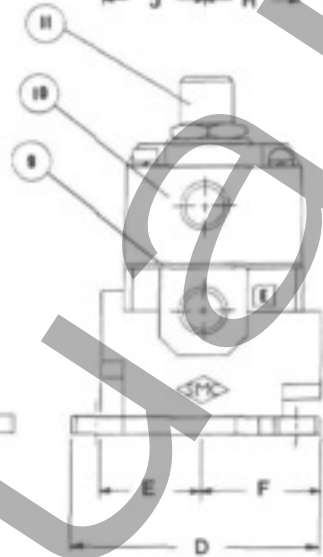

DIMENSIONS

A	B	C	D	E	F	G	H	J	K	M	N	O	P	Q	R	S
2.95	2.52	0.75	2.24	0.91	1.06	1.97	0.83	0.94	0.16	1.34	1.22	0.55	0.12	0.47	0.73	0.98
(75)	(64)	(19)	(57)	(23)	(27)	(50)	(21)	(24)	(4)	(34)	(31)	(14)	(3)	(12)	(18.6)	(25)

Millimeters in Parentheses

NOTES

PARTS LIST

Del. No.	No. Req'd.	Part Name	Part Number
1	1	Body 1/2" NPTF 1/4" NPTF	--
2	1	Spool & Sleeve Asst'y	--
3	1	Spring	AXT338-6
5	4	O-Ring	ARP568-014
6	2	O-Ring	ARP568-016
7	1	Bushing	AXT338-14
8	1	Grommet	AXT338-9
9	1	Cushion	AXT338-5
10	1	Pilot Cover	--
11	1	Recessed non-locking operator (includes O-ring seal)	P60103
12	2	Screw M4 x 30 with washer	AXT338-10

NVSA 3125

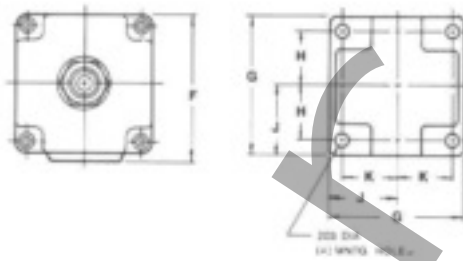

TIGHT MOUNTING
MOUNTING MUST BE MAINTAINED. A TIGHT MOUNTING INSURES THE PROPER OPERATION OF THE VALVE. THE VALVE MUST BE MOUNTED TO A RIGID SURFACE. SURFACE FINISH MUST BE 125 MICRO INCHES. SURFACE FINISH MUST BE 125 MICRO INCHES. SURFACE FINISH MUST BE 125 MICRO INCHES. SURFACE FINISH MUST BE 125 MICRO INCHES.

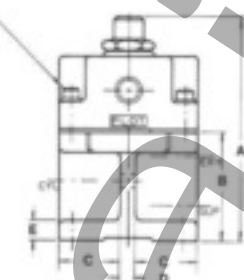
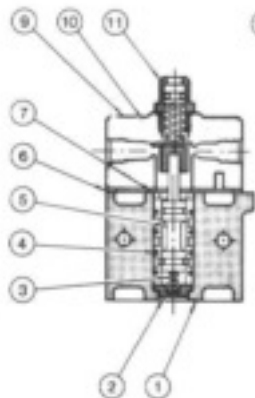

MANUFACTURING
ALL DIMENSIONS ARE IN MILLIMETERS. ALL DIMENSIONS ARE IN MILLIMETERS. ALL DIMENSIONS ARE IN MILLIMETERS. ALL DIMENSIONS ARE IN MILLIMETERS.

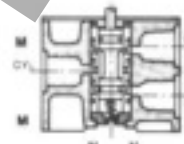

SPECIAL
PILOT COVER
WITHOUT MANUAL OPERATOR

PISTON TAP IS 1/8" NPTF OR AN ALLOY AS SPECIFIED BY MODEL NUMBER

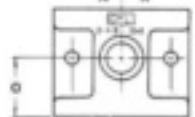

ALL PORTS
1/8" DIA. x 1/32" DEEP
C-BORE FOR ARP568-F12 O-RING

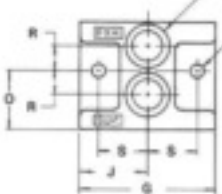

28 DIA.
(2) M10 HOLES
TO CLEARANCE FOR
M6-32 SCREW

DIMENSIONS

A	B	C	D	E	F	G	H	J	K	M	N	O	P	R	S
3.54	1.77	0.94	0.24	0.31	2.24	2.13	0.83	1.06	0.87	0.39	0.79	0.98	2.13	0.39	0.78
(90)	(45)	(24)	(6)	(8)	(57)	(54)	(21)	(27)	(22)	(10)	(20)	(25)	(54)	(9.9)	(19.8)

Millimeters in Parentheses

PARTS LIST

Det. No.	No. Req'd.	Part Name	Part Number
1	1	Valve Body—1/8" NPTF 1/4" NPTF	—
2	1	Spring Seat	XT018-4
3	1	Spring—spool return	XT005-10
4	4	O-ring—Sleeve	ARP568-014
5	1	Sleeve assembly—consists of spool and sleeve (matched set) and (4) detail 4	—
6	1	Gasket—Pilot Cover	XT024-3
7	1	Spacer	AXT018-5
8	1	Pilot cover assembly with operator. Consists of details 10, 11, (4) detail 12 and (3) 1/8" NPTF flush plugs	—
10	1	Pilot cover	—
11	1	Recessed non-locking operator (includes O-ring Seal)	PB0102
12	4	Captive screw—pilot cover	XT012-25B
13	1	Pilot cover assembly without operator. Consists of details 10, 14, (4) detail 12, and (3) 1/8" NPTF flush plugs	—
14	1	Plug—operator mounting hole	B2301-1/4

SERIES
NVSA 3115, 3125
NVSA 3135, 3145

DIRECTIONAL AIR VALVE
DIMENSIONS/PARTS LIST

NVSA 3135
NVSA 3145

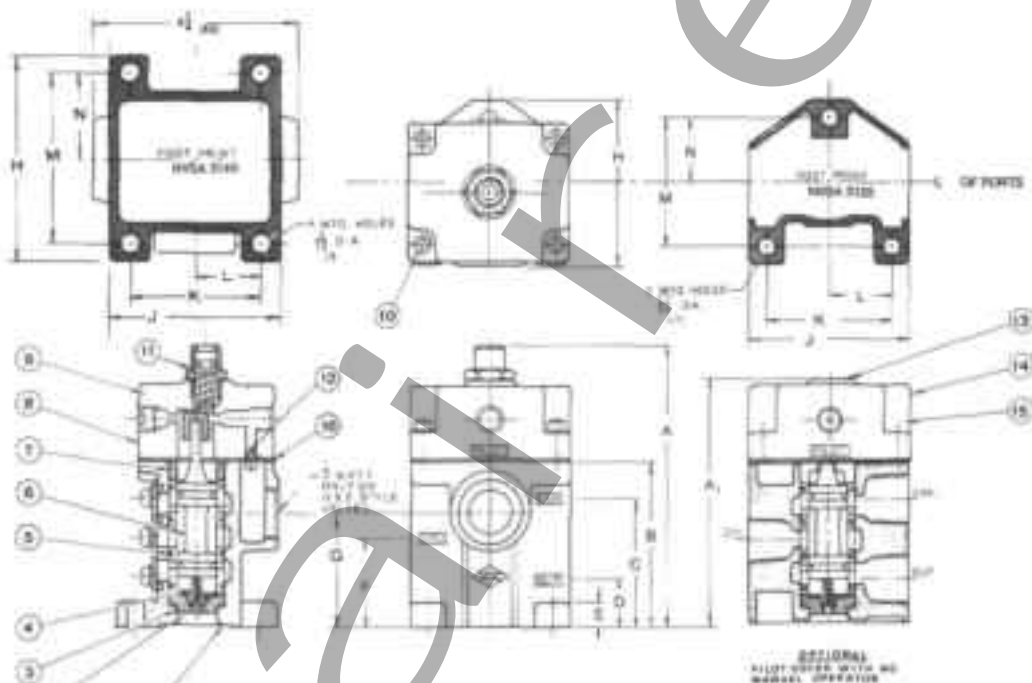

DIMENSIONS

VALVE SIZE	A	A1	B	C	D	E	F	G	H	J	K	L	M	N
NVSA 3135	4.41 (112)	3.86 (98)	2.56 (65)	2.01 (51)	0.75 (19)	0.35 (9)	1.38 (35)	1.77 (45)	2.56 (65)	2.52 (64)	1.97 (50)	0.98 (25)	1.97 (50)	0.98 (25)
NVSA 3145	5.75 (146)	5 (127)	3.48 (88)	2.80 (71)	1.38 (35)	0.47 (12)	2.09 (53)	2.56 (65)	3.19 (81)	3.23 (82)	2.05 (52)	1.02 (26)	2.60 (66)	1.30 (33)

Millimeters in Parentheses

PARTS LIST

Det. No.	No. Req'd	Part Name	NVSA 3135	NVSA 3145
1	1	Valve Body	—	—
2	1	Bumper — spring and	XT013-15	AXT021-14
3	1	Spring seat	KT019-E	AXT105-4
4	1	Spring — spur return	XT010-15	KT103-5
5	4	O-ring — sleeve	ARPS68-018	ARPS68-119
6	1	Sleeve assembly — consists of spool and sleeve (matched set) and IC detail 5	—	—
7	1	Spacer	AXT265-3	XT029-6
8A	1	Pilot cover assembly with manual operator but no junction box pilot connection. Consists of detail 9, 11, (4) detail 10 and (2) 1/8" NPTF flush plugs	—	—
8B	1	Pilot cover assembly with manual operator and with junction box pilot connection. Consists of details 8A, 11, 12B, (4) detail 10 and (4) 1/8" NPTF flush plugs	—	—
9	1	Pilot cover without #10-32 pilot connection	—	—
9A	1	Pilot cover with #10-32 pilot connection	—	—
10	4	Captive screw — pilot cover	KT012-25B	KT012-25B
11	1	Recessed non-rotating operator	P90100	P90400
12A	1	#10-32 plug and gasket	KT015-3A	KT015-3A
12B	1	#10-32 to 1/16" I.D. tube barb	Z11-1	Z11-1
13	1	Plug — operator mounting hole	B2301-1A	B2301-1A
14	1	Pilot cover assembly without manual operator and without junction box pilot connection. Consists of details 9, 13, (4) detail 10 and (2) 1/8" NPTF flush plugs	—	—
15	1	Pilot cover assembly without manual operator but with junction box pilot connection — consists of details 8A, 13, 12B, (4) detail 10 and (4) 1/8" NPTF flush plugs	—	—
16	1	Gasket — pilot cover	XT021-5	XT029-5

**SERIES
NVSA 3114**

**DIRECTIONAL AIR VALVE
MANIFOLD ASSEMBLY**

An optional manifold mounted design is available for the NVSA 3115 valves. The block is aluminum bar stock with common supply and exhaust as well as an individual outlet port on the side.

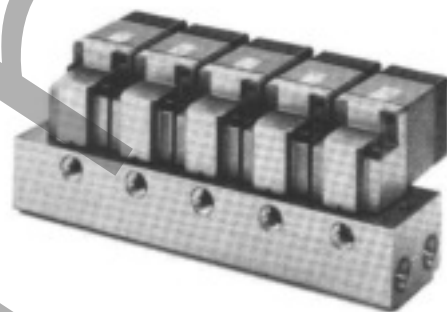
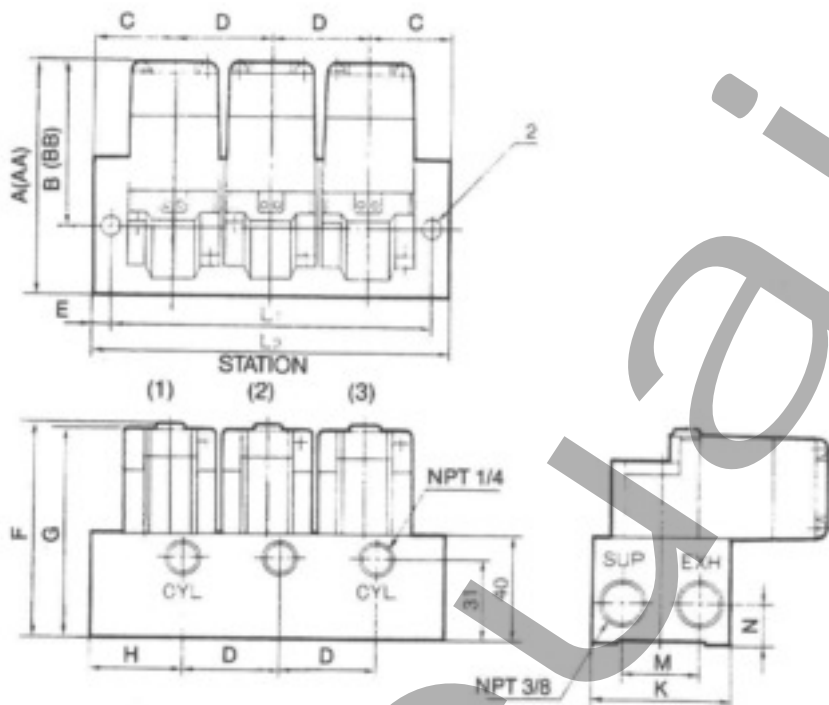

HOW TO ORDER

NVSA 3114-00 N

Refer to page 3
HOW TO ORDER

ORDERING EXAMPLE:

**1 PCE—FOUR STATION MANIFOLD
ASSEMBLY COMPRISING:**

- STATION 1: NVSA 3114-000
- STATION 2: NVSA 3114-000
- STATION 3: NVSA 3114-000
- MA 300-03

MA300-XX
Assy. Kit (when factory assembled)

XX = No. of Stations

DIMENSIONS

A	AA*	B	BB*	C	D	E	F	G	H	K	M	N
3.58 (91)	4.61 (117)	2.56 (65)	3.58 (91)	1.22 (31)	1.50 (38)	0.28 (6.5)	3.29 (83.5)	3.23 (82)	1.42 (36)	2.05 (52)	1.10 (28)	0.59 (15)

*Dimension if DC Solenoid is Used

Millimeters in Parentheses

MANIFOLD DIMENSIONS

L	2	3	4	5	6	7	8	9	10
L ₁	3.43 (87)	4.92 (125)	6.42 (163)	7.91 (201)	9.41 (239)	10.91 (277)	12.40 (315)	13.90 (353)	15.39 (391)
L ₂	3.94 (100)	5.43 (136)	6.93 (176)	8.43 (214)	9.92 (252)	11.42 (290)	12.91 (328)	14.41 (366)	15.91 (404)

Millimeters in Parentheses

SERIES
NVSA 4014

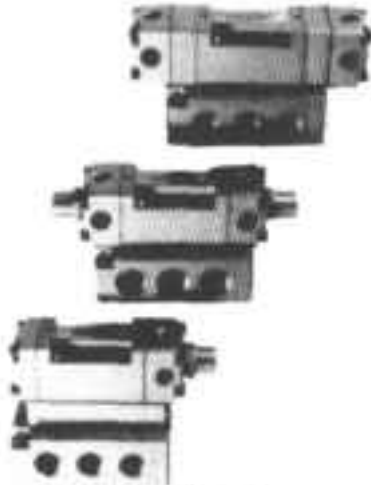

SPECIFICATIONS

ANSI Symbol

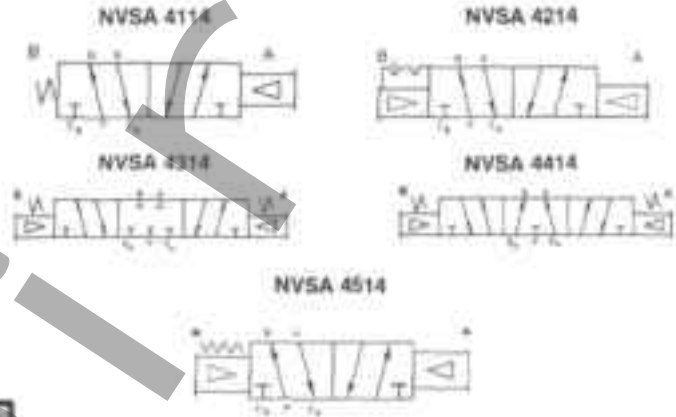

Characteristic	NVSA 4014	
Cv Rating in sub-plate:	1/2" NPT C _v 0.8 1/2" NPT C _v 1.0 3/4" NPT C _v 1.0	
Operating	NVSA 4114 4214 4514	NVSA 4314/4414
Spool Stroke:	0.126" (3.2 mm.)	0.136" (3.5 mm.)
Pilot Pressures*: 1. To start spool shifting 2. To shift spool fully 3. Maximum permissible:	8 PSIG (0.55 Bar) 18-20 PSIG (1.24 Bar) 150 PSIG (10.3 Bar)	18 PSIG 25 PSIG 150 PSIG (10.3 Bar)
Media:	Air (lubricated or oil-free, any non-flammable, non-toxic, non-corrosive gases except oxygen).	
Leakage:	Port to port (internal) not to exceed 0.007 cubic feet per minute at 100 PSIG (6.9 kg/cm ²).	
Operating Pressures:	25" Vacuum to 300 PSIG (20 kg/cm ²).	
Materials:	All housing parts aluminum die castings. Spool and sleeve 440F stainless steel, heat treated to 55-62 Rockwell C and passivated. Sleeve O-rings Buna N. Spacers Delrin. Bumper urethane rubber.	
Maximum ambient temperature:	140°F (50°C)	

*Note: These pilot pressures apply only to a clean, well lubricated valve.

DESIGN:

This design concept consists of a Match-Ground "SPOOL & SLEEVE" assembly which controls the main valving functions. This match ground fit creates an "Air Bearing" effect for extended and efficient operation and eliminates the need for resilient seals. Large capacity air flows are achieved by application of the SMC U.S. Patents applicable to this type of valve. Should the valve require disassembly for maintenance the Spool and Sleeve should be retained as a unit.

GENERAL

Heavy duty air valves built to comply with JIC and all industrial standards. Designed specifically for use in co-operation with air logic. Recessed non-locking manual operator available on all models. Type "N" and "D" valves operate through "external" pilot pressure supply port on top of valve. Type "A" and "B" valves may be operated through "internal" pilot pressure supply port situated in either their sub-plate (SPA) or stacking manifold blocks (MBA).

PILOT IDENTIFICATION:

The official standard for diagramming air logic is National Fluid Power Association Recommended Standard T3.25.9-1973 "Method of Diagramming for Moving Part Fluid Controls." The entire standard is built around the identification of the pilots as "A" and "B". The valve body carries this identification and conforms with the NFPA standard.

PILOT PRESSURE CHARACTERISTICS

The spool has no seals, and is balanced to air pressures. Thus the pressure in the valve has no effect on the pilot pressure required to shift the spool. The pilot pressure required is always constant, regardless of the pressure in the main passages.

This feature makes the valves the ideal companion for air logic systems, assuring a constant response from cycle to cycle. No other type of valve action provides this constant response.

The standard output pressure for moving part air logic is 50 PSIG (3.44 Bar). The low pilot pressure required by these valves gives extremely fast response to energize. Minimum volume of the pilot chamber, and small swept volume displaced by the short-stroke spool also aid fast response.

PILOT PRESSURE PORTS

Type A & B SMC Class 1 valves are designed to accept Pilot Pressures "Internally." Interconnecting pilot passages located in the base of the valve automatically channel pilot air to the appropriate operating chambers of the valve when the valve is mounted onto either a pilot ported subplate or the MBA manifold blocks. This eliminates the need of disconnecting pilot lines when valve is replaced in the field.

MULTI-PURPOSE FLOW PATTERN

True multi-purpose valve. Any port may be pressurized, back-pressured, or plugged without affecting spool action. ANSI symbol shows the valve as a single inlet 4-way, but valve may be used, without modification, as a dual inlet 4-way, a 3-way, or a 2-way, by zipping and/or plugging the appropriate ports.

MOUNTING

Intended for sub-plate or manifold mounting. May be mounted in any position.

HOW TO ORDER

This model number is a coded number which describes all available options.

NVSA 4 2 1 4 - 00 A M

Type of Actuation

1. Single Pilot, Spring return
2. Double Pilot, detented
3. Double Pilot, spring centered (all ports blocked in neutral)
4. Double Pilot, spring centered (cyl. ports open to exhaust in neutral)
5. Double Pilot, spring offset

Optional

- M = Interface Speed Control
- V1 = Red Pilot Indicator
- V2 = Green Pilot Indicator

Optional Features

- A = Recessed non-latching operator - pilot pressure, access through base of valve.
- B = No operator - Pilot pressure access through base of valve.
- N = Recessed non-latching operator - "External" pilot connection.
- O = No operator - "External" pilot connection.

Porting

00 = Indicates valve unit only - no base (includes sub-plate gasket & hold down bolts)

Use For Valve Type

- N&O A&B**
- 41 *S1 = Mounted on individual sub-plate - 1/2" NPT side ports (5) - dual exhaust
 - 42 *S2 = Mounted on individual sub-plate - 1/2" NPT side ports (5) - dual exhaust
 - 43 *S3 = Mounted on individual sub-plate - 1/2" NPT side & bottom ports (10) - dual exhaust
 - 44 *S4 = Mounted on individual sub-plate - 1/2" NPT bottom ports (5) - dual exhaust
 - 45 *S5 = Mounted on individual sub-plate - 1/2" NPT side ports (5) - dual exhaust

- 11 *12 = Mounted on stacking manifold block 1/2" NPT side ports (2)
- 12 *14 = Mounted on stacking manifold block 1/2" NPT side & bottom ports (4)
- 13 *16 = Mounted on stacking manifold block 1/2" NPT side (2) & bottom (2) ports

*These manifolds & sub-plates incorporate 1/2" NPT "pilot pressure" ports for supplying "internal" pilot pressure to the valves. *Type A and B valves only

To Specify "Factory Built" Valve/Manifold Assembly:

1. Establish the number of stations required
2. Select the type of valve required on each station.
3. Choose Manifold Block desired - e.g. #12, #14 or #16.
4. To specify a valve mounted on a manifold block - Insert manifold number into valve number i.e. NVSA 4114-11N is a NVSA 4114-00N valve mounted on a #11 block.

To Order "Factory Built" Valve/Manifold Assembly:

EXAMPLE 1 Pos. Four Station Manifold Assy comprising:

- Station 1. NVSA 4114-12A
- Station 2. NVSA 4114-14A
- Station 3. NVSA 4214-12A
- (2) Blocking Discs in P, EA & EB galleries.
- Station 4. #16 Manifold Block & Blank Station Kit
- 1. ME 401LR-4 Assembly Kit

SUBPLATES AND MANIFOLDS

(To order valves mounted on subplates or manifolds, insert "XX" into Valve No.)
Example: NVSA 4114-XX-A

SUBPLATES (N & O Type Valve)

PART NO.	PORTING	(No. of Ports)	"XX"
SF 0111	1/2" NPT Side	(5)	41
SF 0112	1/2" NPT Side	(5)	42
SF 0113	1/2" NPT Side (5), 1/2" NPT Bottom	(5)	43
SP 0114	1/2" NPT Bottom	(5)	44
SP 0115	1/2" NPT Side	(5)	45

SUBPLATES (A & B Type Valve 1/2" NPT Pilot Ports)

PART NO.	PORTING	(No. of Ports)	"XX"
SPA 0111	1/2" NPT Side	(5)	51
SPA 0112	1/2" NPT Side	(5)	52
SPA 0113	1/2" NPT Side (5), 1/2" NPT Bottom	(5)	53
SPA 0114	1/2" NPT Bottom	(5)	54
SPA 0115	1/2" NPT Side	(5)	55

MANIFOLDS

PART NO.	PORTING	(No. of Ports)	"XX"
MBA 4010-02	1/2" Side	(2)	12
MBA 4011-02	1/2" Side, 1/2" Bottom A & B	(4)	14
MBA 4210-02	1/2" Side (2), 1/2" Bottom	(5)	16

ACCESSORIES

PART NUMBER	DESCRIPTION	PCS. REQ.
ME 401 LR	Left & Right End Plates Includes (3) O-Rings ARP 565-015 (1) Plug AXT 336-0	1 Pr.
ME 401 BLR	Left & Right End Plates - Short w/o Conduit NPT Threads. Includes (3) O-Rings ARP 565-015.	1 Pr.
AXT 336-5*	Tierods - Includes (2) M16x25 Screws Per Rod.	2 Req.
AXT 336-4*	Conduit Cover - Includes (4) 8.32 x 1/2" screws. Note: Not required if using ME401BLR End Plates.	1
AXT 336-B	Gallery Blocking Disc	-
AXT 336-7A	Blank Station Kit	-
AXT 337-4	Right - Pilot Air Gasket	-
AXT 337-5	Left - Pilot Air Gasket	-
ARP 565-015	(3) Manifold O-Ring	-

*Add No. of Stations

SERIES
NVSA 4014

DIRECTIONAL AIR VALVE
DIMENSIONS
PARTS LIST

NVSA 4114

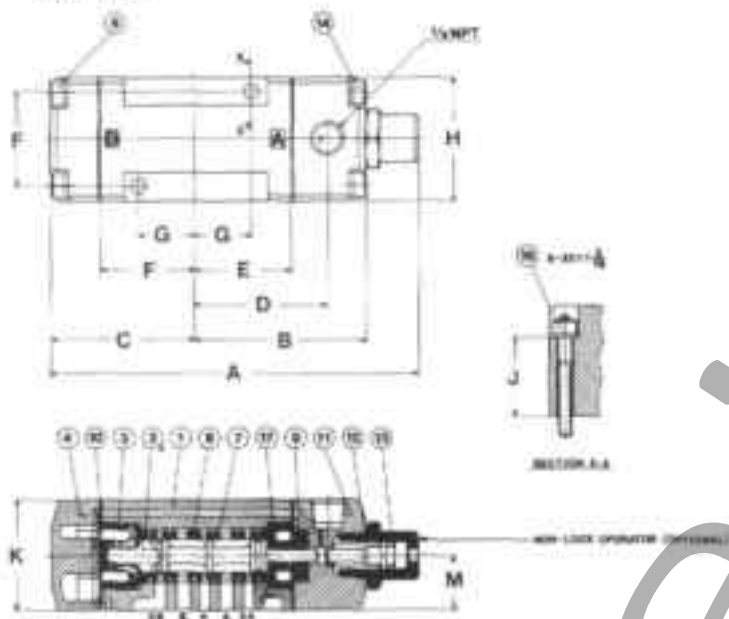

Dimensions

A	B	C	D	E	F	G	H	J	K	M
4.17 (105.8)	1.39 (35.3)	1.43 (36.3)	1.50 (38.1)	1.10 (27.9)	1.06 (27)	0.63 (16)	1.42 (36)	0.01 (0.3)	1.28 (32)	0.01 (0.3)

Millimeters in Parentheses

PARTS LIST

DETAIL REF.	DESCRIPTION	MATERIAL	PART NO.
1	Body	Alum. D.C.	—
2	Spring - Return	—	AXT 333-93
3	Spring - Seat	—	AXT 333-8
4	End Cap w/4 Screws	Alum. D.C.	EG 0111-1
5	End Cap	Alum. D.C.	—
6	Screws - End Cap (4)	—	—
7	Spool & Sleeve Ass'y.	440F. S.S.	—
8	O-Rings - 5 & 5 (6)	Buna N	ARP 588-014
9	Cushion-Pilot Cover "A" and	—	AXT 334-5N
10	Gasket-Pilot Cover & End Cap (2)	Buna N	AXT 334-7N-1
PILOT COVERS			"A" END "B" END
11A	Type "O" w/o Operator, w/4 screws (2)	Alum. D.C.	PC 0100-1
11B	Type "N" w/Operator & (4) Screws (2)	Alum. D.C.	PC 0101-1
11C	Type "B" w/o Operator w/4 Screws	Alum. D.C.	PC 0110-1 —
11D	Type "A" w/Operator & (4) Screws	Alum. D.C.	PC 0111-1 —
12	O-Ring - Operator	Buna N	—
13	Recessed Non-Locking Operator	—	PB 0103
14	Screws - Pilot Cover (4)	—	—
15	Gasket - Subplate	Buna N	AXT 335-12-2
16	Hold Down Bolt (8.32 x 1 1/4") (2)	—	NXT 333-17-5
17	Bumper - "A" End	—	AXT 333-10

NVSA 4214

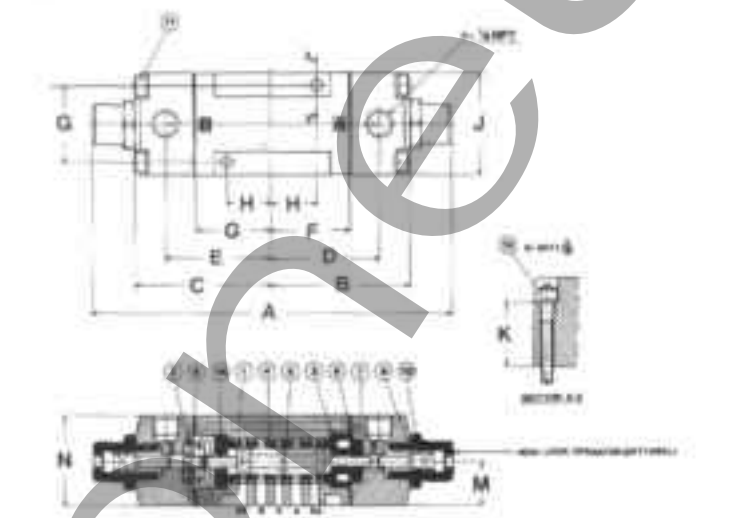

Dimensions

A	B	C	D	E	F	G	H	J	K	M
5.12 (130)	1.39 (35.3)	1.39 (35.3)	1.52 (38.5)	1.40 (35.5)	1.10 (27.9)	1.06 (27)	0.63 (16)	1.42 (36)	0.01 (0.3)	1.28 (32)

Millimeters in Parentheses

PARTS LIST

DETAIL REF.	DESCRIPTION	MATERIAL	PART NO.
1	Body	Alum. D.C.	—
2	Detent Ass'y.	—	AXT 333-20
3	Spacer - "A" End	—	AXT 333-10
4	Spool & Sleeve Ass'y.	440 F.S.S.	—
5	O-Ring - 5 & 5 (6)	Buna N	ARP 588-014
6	Gasket - Pilot Covers (2)	Buna N	AXT 334-7N-1
PILOT COVERS			"A" END "B" END
7A	Type "O" - w/o Operator w/4 Screws (2)	Alum. D.C.	PC 0100-1
7B	Type "N" - w/Operator & (4) Screws (2)	Alum. D.C.	PC 0101-1
7C	Type "B" - w/o Operator w/4 Screws (ea.)	Alum. D.C.	PC 0110-1 PC 0120-1
7D	Type "A" - w/Operator & (4) Screws (ea.)	Alum. D.C.	PC 0111-1 PC 0121-1
8	Cushion-Pilot Cover "A" End	—	AXT 334-5N
9	O-Ring - Operator	Buna N	—
10	Recessed Non-Locking Operator	—	PB 0103
11	Screws - Pilot Covers (4)	—	—
12	Hold Down Bolt (8.32 x 1 1/4")	—	NXT 333-17-5
13	Gasket - Subplate	Buna N	AXT 335-12-2
14	Cushion - "B" End	—	AXT 334-5

SERIES
NVSA 4014

DIRECTIONAL AIR VALVE
DIMENSIONS
PARTS LIST

NVSA 4314/4414

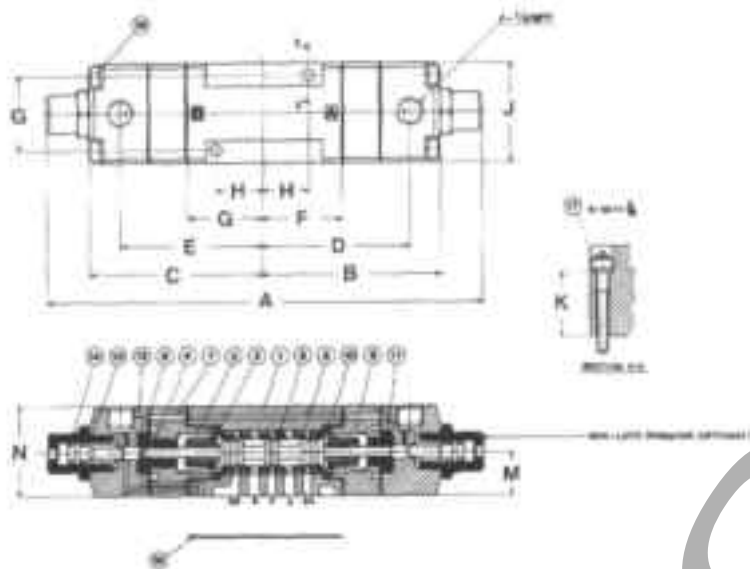

Dimensions

A	B	C	D	E	F	G	H	J	K	M	N
6.10 (155)	2.48 (63)	2.44 (62)	2.05 (52)	2.01 (51)	1.10 (28)	1.00 (25)	0.83 (21)	1.42 (36)	0.01 (0.3)	0.21 (5.3)	1.26 (32)

Millimeters in Parentheses

PARTS LIST

DETAIL REF.	DESCRIPTION	MATERIAL	PART NO.
1	Body	Alum. D.C.	—
2	Spring - Seat	(2)	AXT 334-10
3	Spring - Centring	(2)	AXT 334-14
4	Cushion - Pilot Cover "B" End	—	AXT 334-12-2
5	Spool & Sleeve	440F S.S.	—
6	O-Ring - S & S - (8)	Buna N	ARF 568-014
7	Spacer - "B" End	—	AXT 334-15-2
8	Gasket - Pilot Cover & Spacers (4)	Buna N	AXT 334-79-1
9	Spacer - "A" End	—	AXT 334-16-1
10	Bushing - Body	(2)	AXT 334-22-6
11	Cushion - Pilot Cover "A" End	—	AXT 334-12-1
			"A" END "B" END
12A	Type "O" - w/o Operators (4) Screws (8x.) (2)	Alum. D.C.	PC 0102-1
12B	Type "V" - w/Operator & (4) Screws (8x.) (2)	Alum. D.C.	PC 0103-1
12C	Type "B" - w/o Operator, w/4 Screws (8x.)	Alum. D.C.	PC 0112-1 PC 0122-1
12D	Type "A" - w/Operator & (4) Screws (8x.)	Alum. D.C.	PC 0113-1 PC 0123-1
13	O-Ring - Operators	Buna N	—
14	Recessed Non-Locking Operators	Alum. D.C.	PB 0103
15	Gasket - Subplate	Buna N	AXT 335-12-2
16	Screws - Pilot Cover (4)	—	AXT 334-10-1
17	Hold Down Bolts (5/32 x 1 1/4") (2)	—	NXT 333-17-5

NVSA 4514

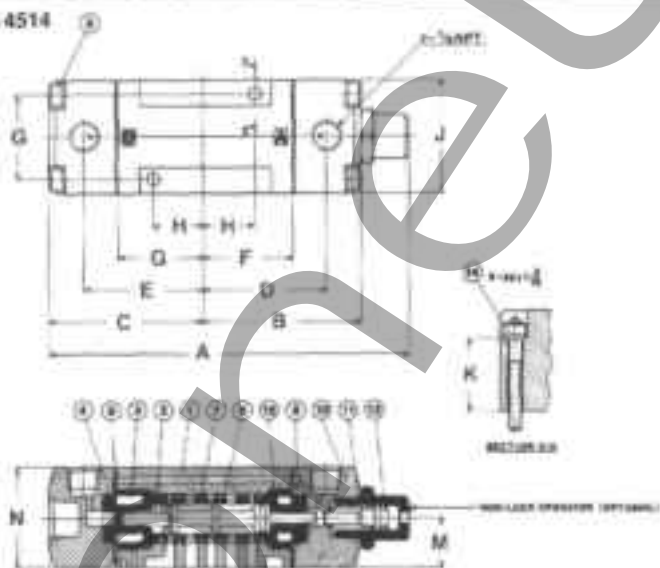

Dimensions

A	B	C	D	E	F	G	H	J	K	M	N
4.57 (116)	1.95 (49.5)	1.98 (50.5)	1.52 (38.5)	1.48 (37.5)	1.10 (28)	1.08 (27)	0.83 (21)	1.42 (36)	0.01 (0.3)	0.01 (0.3)	1.26 (32)

Millimeters in Parentheses

PARTS LIST

DETAIL REF.	DESCRIPTION	MATERIAL	PART NO.
1	Body	Alum. D.C.	—
2	Spring - Return	—	AXT 333-9-3
3	Spring - Seat	—	AXT 333-8
			PILOT COVER "B" END
4A	Type "N & O" w/4 Screws	—	PC 0100-1
4B	Type "A & B" w/4 Screws	—	PC 0111-1
5	Screw - Pilot Cover (4)	—	—
6	Spool & Sleeve Ass'y.	440F S.S.	—
7	O-Ring - S & S - (8)	Buna N	ARF 568-014
8	Cushion - Pilot Covers "A & B" (2)	—	AXT 334-6N
9	Gasket - Pilot Covers (2)	Buna N	AXT 334-79-1
			PILOT COVERS "A" END
10A	Type "O"	Alum. D.C.	PC 0100-1
10B	Type "N"	Alum. D.C.	PC 0101-1
10C	Type "B"	Alum. D.C.	PC 0110-1
10D	Type "A"	Alum. D.C.	PC 0111-1
11	O-Ring - Operator	Buna N	—
12	Recessed Non-Locking Operator	—	PB 0103
13	Gasket - Subplate	Buna N	AXT 335-12-2
14	Hold Down Bolts (5/32 x 1 1/4")	—	NXT 333-17-5
15	Spacer "A" End	—	AXT 333-10

SERIES
NVSA 4014

DIRECTIONAL AIR VALVE
SUBPLATES

General:

Sub-plates are heavy duty aluminum die castings. All ports are marked with identification in accordance with American National Standards Institute standard ANSI B93.9-1969 "Symbols for Marking Electrical Leads and Ports on Fluid Power Valves."

Pilot Pressure Ports:

Style "SP" sub-plates do not provide for pilot pressure connections through the sub plate.

Style "SPA" sub-plates incorporate (2) 1/8" NPT "Pilot Pressure" ports for supplying "Internal" pilot pressure to Type A & B Air Piloted Valves Only.

NOTE — Type "T" solenoid valves provide for electrical wires to exit from the top surface of valve.

SUB-PLATE MODEL NO.	"XX" NO.		N	P	PORT LOCATION				
	"SP"	"SPA"			T	P	A	B	EA
SP & SPA 0111	41	51	1/4	S	S	S	S	S	S
SP & SPA 0112	42	52	1/4	S	S	S	S	S	S
SP & SPA 0113	43	53	1/4	S/B	S/B	S/B	S/B	S/B	S/B
SP & SPA 0114	44	54	1/4	B	B	B	B	B	B
SP & SPA 0115	45	55	1/4	S	S	S	S	S	S

"FOOTPRINT"
CLASS 1 SUB-PLATE
MOUNTED 4-WAY VALVES

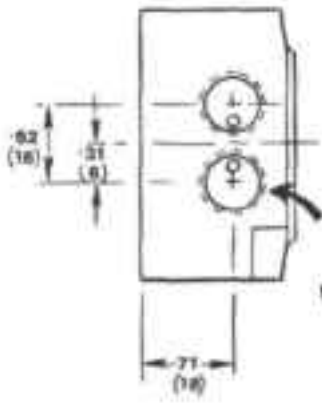
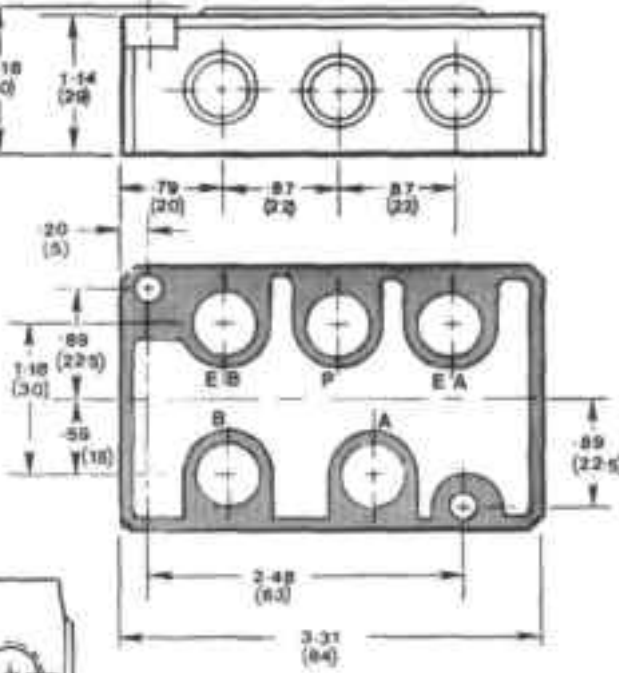
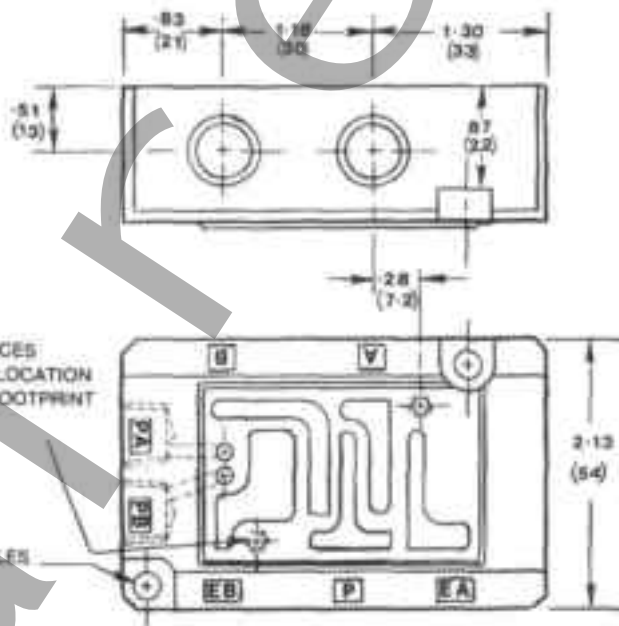

NOTE
PILOT PORTS ONLY IN "SPA" SUBPLATES

NOTE NUMBERS IN PARENTHESES ARE MILLIMETERS
SHADED AREA IS IN CONTACT WITH MOUNTING SURFACE

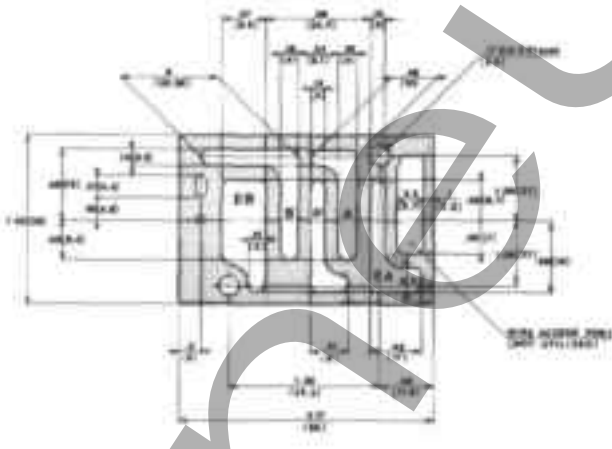

**DIRECTIONAL AIR VALVE
MANIFOLD ASSEMBLY**

**SERIES
NVSA 4014**

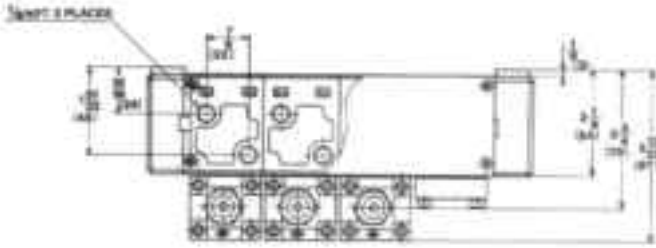

Application

Normally this manifold arrangement is used for single Pressure, Four Way valve circuitry, where pressure is applied to the (P) common gallery and exhausts through the dual (EA & EB) common galleries. However many other circuit capabilities are easily obtained by the inter-mingling of different types of SMC Multi-Purpose Air Piloted and Solenoid valves in combination with their basic manifold units. The use of Gallery Blocking Disc within the assembly further expands system capabilities. Side cylinder ports "A" & "B" are located on the "B" side of the manifold and "Station" identification is obtained by numbering from left to right as viewed from the "B" Solenoid side.

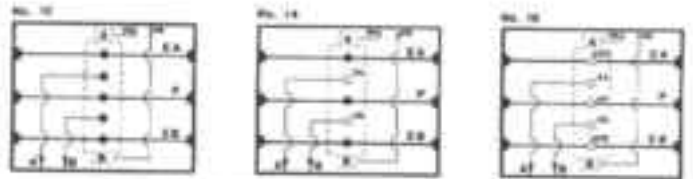
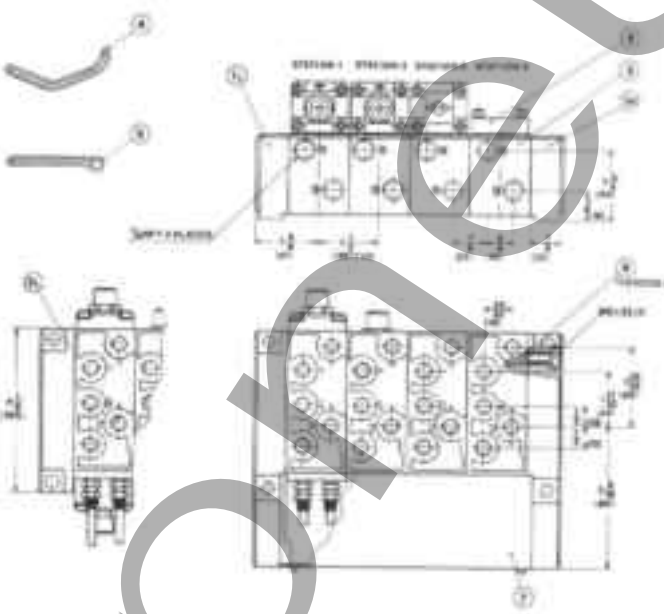
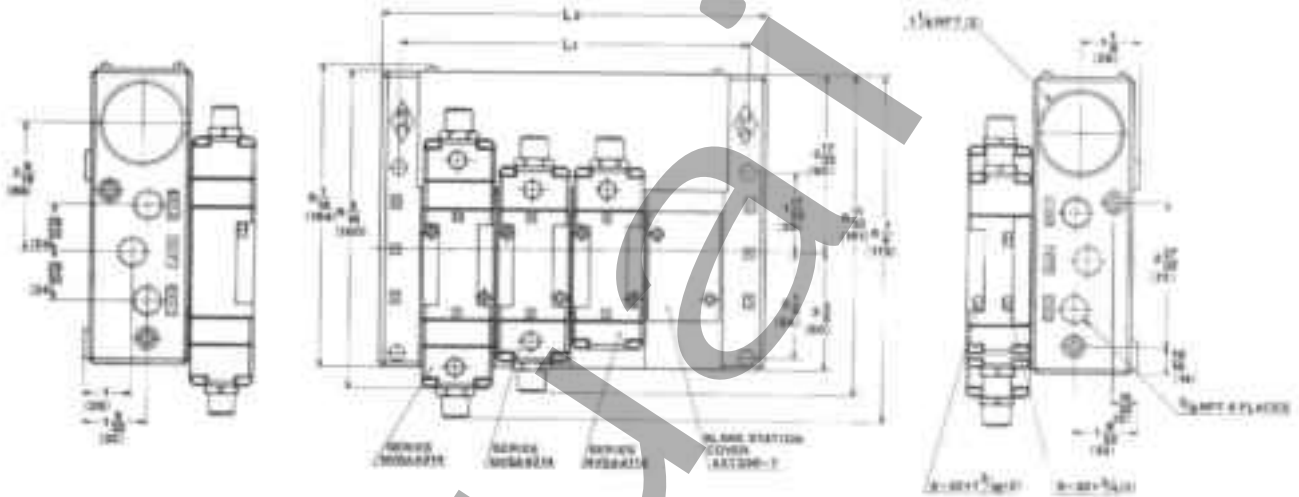

MANIFOLD BLOCK PART NO.	"XX" NO.	PRESSURE		CYLINDER "A & B"		EXHAUST "EA & EB"	
		GALLERY	BOTTOM	SIDE	BOTTOM	GALLERY	BOTTOM
MBA 4010-02	12	Yes	—	5" (2)	—	Yes	—
MBA 4011-02	14	Yes	—	5" (2)	5" (2)	Yes	—
MBA 4210-02	16	Yes	5" (1)	5" (2)	5" (2)	Yes	5" (2)

STATIONS	2	3	4	5	6	7	8	9	10
L ₁	4 3/8 (103)	5 1/8 (141)	7 1/8 (179)	8 1/8 (217)	10 1/8 (255)	11 3/8 (293)	13 1/8 (331)	14 1/8 (369)	16 1/8 (407)
L ₂	4 7/8 (120)	6 3/8 (158)	7 7/8 (196)	9 3/8 (234)	10 7/8 (272)	12 3/8 (310)	13 7/8 (348)	15 3/8 (386)	16 7/8 (424)

L₁ = 36N + 27
L₂ = 36N + 44

**SERIES
NVSA 4014**

**DIRECTIONAL AIR VALVE
INTERFACE SPEED CONTROL
PILOT INDICATORS**

INTERFACE SPEED CONTROL

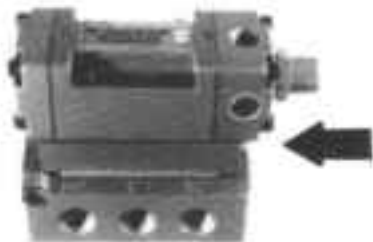

GENERAL

This Speed Control is an Aluminum die cast Interface Plate having on its upper surface a mounting pattern which accepts all SMC Class 1 solenoid and air operated valves and with a lower surface which mounts onto all subplates and manifolds applicable to these Class 1 valves.

INSTALLATION

The Speed Control is mounted between the subplate/manifold and the valve by utilizing 1/4" longer bolts in place of the standard valve Hold Down bolts. May be field installed without system or piping modifications.

TO ORDER FOR FIELD REPLACEMENT

- Kit Number Comprising of
- SPA 0100 1 — #AXT 332 Speed Control Block.
 1 — #AXT 335-12-2 Gasket.
 2 — #NXT 333-17 Hold Down Bolts (#6-32 x 1 1/4)

TO ORDER AS PART OF VALVE/MANIFOLD ASSY

ADD Suffix "M" to part number.
 Example: Part Number #NVSA 4114-52AM — A #NVSA 4114-00A valve mounted on #SPA 0112 subplate with a #SPA 0100 Interface Speed Control between.

FEATURES

1. Eliminates expense of piping and "External" Flow Controls.
2. Simplifies installation by eliminating piping.
3. Provides for "Meter-Out" flow adjustments from Zero to 90% of valves' Full flow capacity in 12 turns of needle.
4. Allows for transfer of "Pilot Pressure" to the valve when used with Type "A" & "B" (internal pilot) air operated NVSA valves.
5. Improves system appearance.

OPERATION

Cylinder speeds may be independently controlled by adjustment of the needle valves in the "EA" & "EB" ports of the speed control block. These needle valves control flows of exhaust air from the valve and are "Vibrationproof" and of "Non-Rising" design.

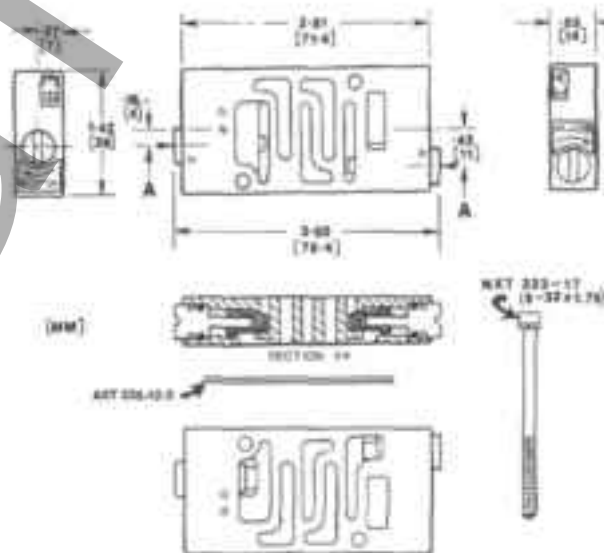

PILOT INDICATORS

These brass plugs when placed into the 1/8" Pilot Ports of an "A or B" style NVSA allow you to know if and when pressure is in the Pilot cavity. You have an option of either a red or green rising pin on your indicator.

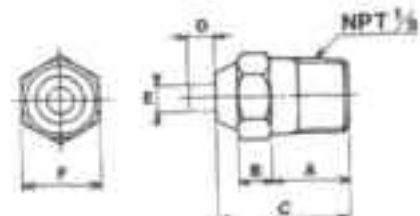

A	B	C	D	E	F
0.39 (10)	0.16 (4)	0.67 (17)	0.12 (3)	0.14 (3.5)	0.29 (7.5)

HOW TO ORDER

PART NO.	SUFFIX NO.	DESCRIPTION
VR 3135-01R	V1	Red "Pop Up" Indicator 1/8" NPTF
VR 3135-01G	V2	Green "Pop Up" Indicator 1/8" NPTF



Example: NVSA 4114-52AV2

SERIES
NVSA 4○24, 4○34
NVSA 4○44

DIRECTIONAL AIR VALVE
AIR PILOT OPERATED

SPECIFICATIONS

CHARACTERISTICS	NVSA 4○24					NVSA 4○34					NVSA 4○44				
	NVSA 4124	NVSA 4224	NVSA 4324	NVSA 4424	NVSA 4524	NVSA 4134	NVSA 4234	NVSA 4334	NVSA 4434	NVSA 4534	NVSA 4144	NVSA 4244	NVSA 4344	NVSA 4444	NVSA 4544
C _y Rating on Subplates: 1/4"	1.47	1.47	1.47	1.47	1.47	—	—	—	—	—	—	—	—	—	—
	3/8"	1.81	1.81	1.81	1.81	2.39	2.39	2.39	2.39	2.39	—	—	—	—	—
	1/2"	—	—	—	—	2.72	2.72	2.72	2.72	2.72	3.78	3.78	3.78	3.78	3.78
	3/4"	—	—	—	—	—	—	—	—	—	4.44	4.44	4.44	4.44	4.44
Spool Stroke: in. (mm)	0.177 (4.5)	0.177 (4.5)	0.394 (10)	0.394 (10)	0.177 (4.5)	0.197 (5)	0.197 (5)	0.434 (11)	0.434 (11)	0.197 (5)	0.386 (9.8)	0.386 (9.8)	0.646 (16.4)	0.646 (16.4)	0.386 (9.8)
Pilot Pressure*: PSIG (kgf/cm ²)	125 PSIG (8.3 kgf/cm ²)														
1. To start spool shifting:	4.0 (0.27)	—	3.5 (0.24)	3.5 (0.24)	4.0 (0.28)	6.0 (0.40)	—	3.5 (0.24)	3.5 (0.24)	6.0 (0.41)	8.0 (0.53)	—	6.5 (0.45)	6.5 (0.45)	8.0 (0.55)
2. To shift spool fully:	10-12 (0.69)	10-12 (0.69)	10-12 (0.69)	10-12 (0.69)	10-12 (0.69)	10-12 (0.69)	10-12 (0.69)	10-12 (0.69)	10-12 (0.69)	10-12 (0.69)	13-15 (0.87)	8-10 (0.53)	13-15 (0.89)	13-15 (0.89)	13-15 (0.89)
3. To return spool with pressure on "A" pilot:	—	—	—	—	"A" pilot pressure minus 10 (0.69)	—	—	—	—	"A" Pilot Pressure minus 10 (0.69)	—	—	—	—	"A" Pilot Pressure minus 10 (0.69)
4. Maximum Permissible	125 PSIG (8.3 kgf/cm ²)														
Maximum Ambient Temperature:	140° F (60° C)														
Media: Air (lubricated or oil free), any non-flammable, non-toxic, non-corrosive gases except oxygen.															
Leakage: Port to Port (internal) not to exceed 0.035 cubic feet per minute at 100 PSIG (6.9 kgf/cm ²)															
Operating Pressures: 28" Vacuum to 300 PSIG (20 kgf/cm ²)															
Materials: All housing parts aluminum die castings. Spool and sleeve 440F stainless steel, heat treated to 58-62 Rockwell C and passivated. Sleeve O-Rings Buna N. Spacers Delrin. Bumper urethane rubber.															

*Note: These pilot pressures apply only to a clean, well lubricated valve.

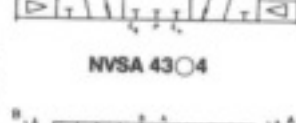
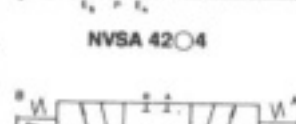
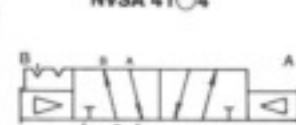

DESIGN

This design concept consists of a Match-Ground "SPOOL & SLEEVE" assembly which controls the main valving functions. This match-ground fit creates an "Air Bearing" effect for extended and efficient operation and eliminates the need for resilient seals. Large capacity air flows are achieved by application of the SMC U.S. Patents applicable to this type of valve. Should the valve require disassembly for maintenance the Spool and Sleeve should be retained as a unit.

GENERAL:

Heavy duty air valves built to comply with JIC and all industrial standards. Designed specifically for use in co-operation with air logic. Optional pilot connection in junction box and large tapped junction box cover allow logic control tubes to be run into the junction box through electrical conduit or air hose used as conduit, thus avoiding exposed control tubes. Junction box is splash-proof and oil-tight.

PILOT IDENTIFICATION:

The official standard for diagramming air logic is National Fluid Power Association Recommended Standard T3.28.9-1973 "Method of Diagramming for Moving Part Fluid Controls. The entire standard is built around the identification of the spring end of the valve as the "B" end, and the pilot end of the valve as the "A" end. The valve body carries this identification and conforms with the NFPA standard.

PILOT PRESSURE CHARACTERISTICS:

The spool has no seals, and is balanced to air pressures. Thus the pressure in the valve has no effect on the pilot pressure required to shift the spool. The pilot pressure required is always constant, regardless of the pressure in the main passages.

This feature makes the valves the ideal companion for air logic systems, assuring a constant response from cycle to cycle. No other type of valve action provides this constant response.

The standard output pressure for moving part air logic is 50 PSIG. (3.4 kgf/cm²). The low pilot pressure required by these valves gives extremely fast response. Minimum volume of the pilot chamber, and small swept volume displaced by the short-stroke spool also aid fast response.

SINGLE PILOT SPRING RETURN

Air operates the spool directly, and a spring returns the spool when air is exhausted.

DOUBLE PILOT DETENTED

Air operates the spool directly. A mechanical detent holds the spool securely in either spool position, as required by major automotive safety standards. Thus a momentary signal will shift the spool, and the detent will hold the spool in the shifted position until the other pilot is pressurized to shift the spool back.

DOUBLE PILOT 3 POSITION SPRING CENTERED

Air operates the spool directly, while two centering springs hold the spool in the center position. Note that each spring centers the spool by means of a spring seal which seats firmly against the end of the sleeve. Thus the spool always centers accurately. The centering springs do not buck each other as in some spring centered valves.

DOUBLE PILOT SPRING OFFSET

The double pilot spring offset action is an unusual action not available with most other valve constructions. When pilot pressure is introduced into the "A" pilot, this pressure acts on the "A" end of the spool, and when the pressure becomes high enough, it forces the spool toward the "B" end, and compresses the spring. If, while the "A" pilot is pressurized, an equal pressure is introduced into the "B" end (the spring cavity) this pressure acts against the "B" end of the spool, and balances the pressure against the "A" end. Now the spring returns the spool to the normal position, even though the "A" end still has pilot pressure in it.

MULTI-PURPOSE FLOW PATTERN:

True multi-purpose valve. Any port may be pressurized, back-pressured, or plugged without affecting spool action. ANSI symbol shows the valve as a single inlet as a single inlet 4-way, but valve may be used, without modification, as a dual inlet 4-way, a 3-way, or a 2-way, by piping and/or plugging the appropriate ports.

MOUNTING:

Intended for sub-plate or manifold mounting. May be mounted in any position. Interchangeable with certain competitive valves on their sub-plates.

SERIES
NVSA 4 24, 4 34
NVSA 4 44

DIRECTIONAL AIR VALVE
AIR PILOT OPERATED

HOW TO ORDER

NVSA 4 1 2 4 - 00 A M

Type of Actuation

- 1 = Single Pilot Spring Return
- 2 = Double Pilot Detented
- 3 = Double Pilot Spring Centered (All ports blocked in neutral)
- 4 = Double Pilot Spring Centered (Cylinder ports open to dual supply in neutral)
- 5 = Double Pilot Spring Offset

Valve Size

- 1 = Class 1
- 2 = Class 2
- 3 = Class 3
- 4 = Class 4

Porting

00 = Indicates valve unit only. No base
(Includes subplate gasket and hold down bolts.)

NVSA 4 24

- 01 = Mounted on Individual Subplate - 1/4" NPTF Side Ports (5)
- 51 = Mounted on Individual Subplate - 1/4" NPTF Side Ports (5); 10-32 Pilot Ports (4)
- 02 = Mounted on Individual Subplate - 3/8" NPTF Side Ports (5)
- 52 = Mounted on Individual Subplate - 3/8" NPTF Side Ports (5); 10-32 Pilot Ports (4)
- 03 = Mounted on Individual Subplate - 1/4" NPTF Bottom Ports (5)
- 06 = Mounted on Individual Subplate - 1/4" NPTF Side Supply (1); Bottom Ports (5)
- 21 = Mounted on Stacking Manifold Block - 3/8" NPTF Side Ports (4)
- 23 = Mounted on Stacking Manifold Block - 3/8" NPTF Side Ports (4); Bottom Ports (2)
- 28 = Mounted on Stacking Manifold Block - 3/8" Side Ports (6); Bottom Ports (5)
- 41 = Mounted on Stacking Manifold Block - 1/2" NPTF Side Ports (4)

NVSA 4 34

- 01 = Mounted on Individual Subplate - 3/8" NPTF Side Ports (5)
- 02 = Mounted on Individual Subplate - 1/2" NPTF Side Ports (5)
- 52 = Mounted on Individual Subplate - 1/2" NPTF Side Ports (5); 10-32 Pilot Ports (4)
- 03 = Mounted on Individual Subplate - 3/8" NPTF Side Ports (5); Bottom Ports (5)
- 31 = Mounted on Stacking Manifold Block - 3/8" NPTF Side Ports (4)
- 33 = Mounted on Stacking Manifold Block - 3/8" NPTF Side Ports (4); Bottom Ports (2)
- 38 = Mounted on Stacking Manifold Block - 3/8" NPTF Side Ports (6); Bottom Ports (5)
- 51 = Mounted on Stacking Manifold Block - 1/2" NPTF Side Ports (4)

NVSA 4 44

- 01 = Mounted on Individual Subplate - 1/2" NPTF Side Ports (5)
- 02 = Mounted on Individual Subplate - 3/4" NPTF Side Ports (5)
- 03 = Mounted on Individual Subplate - 1/2" NPTF Side Ports (5); Bottom Ports (5)
- 04 = Mounted on Individual Subplate - 3/4" NPTF Side Ports (5); Bottom Ports (5)
- 05 = Mounted on Individual Subplate - 1" NPTF Side Ports (5)
- 06 = Mounted on Individual Subplate - 3/4" NPTF Side Ports (5)

Options

- M = Interface Speed Control
- V1 = Red Pilot Indicator
- V2 = Green Pilot Indicator

Features

- A = Recessed non-locking operator, pilot pressure access through base of valve.
- B = No operator—Pilot pressure access through base of valve.
- C = Tapped junction box cover, pilot connections in junction box, but no operator.
- J = Tapped junction box cover, pilot connections in junction box, recessed non-locking operator.
- N = Blank junction box cover, recessed non-locking operator.
- O = Blank junction box cover, no operator.

SERIES
NVSA 4 24, 4 34
NVSA 4 44

NVSA 4124
4134
4144

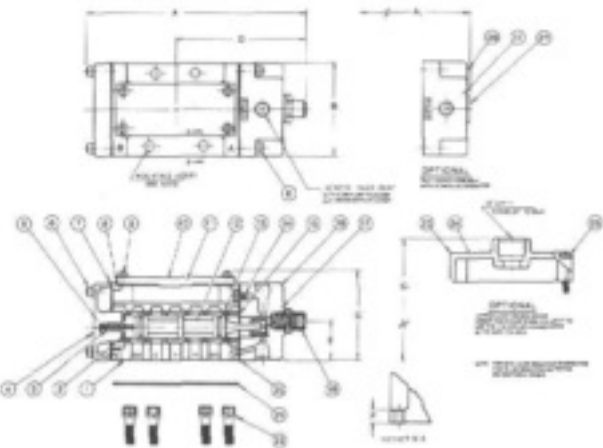

DIMENSIONS

Valve Size	A	A ₁	B	C	C ₁	D	E	F
NVSA 4124	5.39 (137)	4.80 (122)	2.13 (54)	2.36 (60)	3.27 (83)	3.23 (82)	1.06 (27)	0.35 (9)
NVSA 4134	6.06 (154)	5.51 (140)	2.52 (64)	2.44 (62)	3.31 (84)	3.58 (91)	1.06 (27)	0.39 (10)
NVSA 4144	7.25 (185)	6.54 (166)	2.83 (72)	2.99 (76)	3.86 (98)	4.29 (109)	1.22 (31)	0.47 (12)

Millimeters in Parentheses

PARTS LIST

Det. No.	No. Req'd.	Part Name	NVSA 4124	NVSA 4134	NVSA 4144
1	1	Valve Body			
2	1	Bumper—"B" and	AXT340-10-2	AXT340-10-2	AXT021-14
3	1	Spring—Spool Return	X7015-15	X7015-15	KT021-13A
4	1	End plate assembly—			
5	1	End Plate			
6	8	Captive screw	XT012-298	XT012-298	XT012-298
7	1	Gasket—end plate	NX7015-8	XT015-31-2	NX7030-8
8	1	Gasket—junction box cover	NX7015-9	XT015-12-2	NX7030-15
9	4	Captive screw—blank junction box cover	NX7010-11	NX7010-11	NX7010-11
10	1	Junction box cover assembly—blank			
11	1	Junction box cover—Blank			
12	1	Sleeve assembly—Consists of Spool and sleeve (matched set) and (R) detail 13			
13	6	O-ring—sleeve	APPM8-018	APPM8-018	APPM8-119
14A	1	#10-32 plug and gasket	NX7015-34	NX7015-34	NX7015-34
14B	1	#10-32 to 1/8" tube barb and gasket	211-1	211-1	211-1
15	1	Spacer	AXT330-5-18	AXT340-5-1A	X1020-6
16A	1	Pilot cover assembly with manual operator and junction box pilot connection. Consists of details 17A, 14B, 16 and (4) detail 6 and (4) (B) 1/8" NPTF flush plugs.			
16B	1	Pilot cover assembly with manual operator but no junction box pilot connection. Consists of detail 16, (4) detail 6, (2) 1/8" NPTF flush plugs, and detail 17B.			
17A	1	Pilot cover with #10-32 pilot			
17B	1	Pilot cover without #10-32 pilot			
18	1	Recessed non-locking operator	FR0102	FR0102	FR0402
20	1	Gasket—pilot cover	X7024-2	X7027-3	X7029-2
21	1	Gasket—valve body to sub-plate	NX7015-14	X7015-3	X7021-8
22	4	Hold-down bolt and lock washer	NX7015-18 (#10-24x3/4)	NX7030-14 (#14-20x3/4)	NX7030-13 (#14-20x1")
23	1	Junction box cover assembly—tapped. Includes detail 24 and (4) detail 25			
24	1	Junction box cover—tapped			
25	4	Captive screw—tapped junction box cover	X7066-7	X7066-7	NX7013-3
26A	1	Pilot cover assembly without manual operator and with junction box pilot connection. Consists of detail 17A, 14B, 27, (4) detail 6 and (4) 1/8" NPTF flush plugs.			
26B	1	Pilot cover assembly without manual operator and without junction box pilot connection. Consists of detail 27, (4) detail 6, (2) 1/8" NPTF flush plugs and detail 17B.			
27	1	Plug for operator mounting hole.	B2301-14	B2301-14	B2301-14

*NVSA 4124 valves require only (3) hold-down bolts.

NVSA 4224
4234
4244

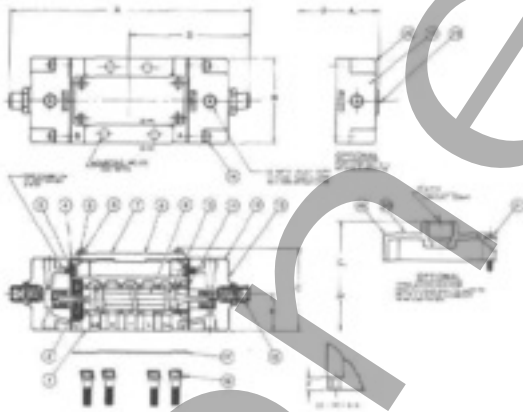

DIMENSIONS

Valve Size	A	A ₁	B	C	C ₁	D	E	F
NVSA 4224	6.54 (166)	5.43 (138)	2.13 (54)	2.36 (60)	3.27 (83)	3.23 (82)	1.06 (27)	0.35 (9)
NVSA 4234	7.20 (183)	6.10 (155)	2.52 (64)	2.44 (62)	3.31 (84)	3.58 (91)	1.06 (27)	0.39 (10)
NVSA 4244	8.90 (226)	7.40 (188)	2.83 (72)	2.80 (71)	3.86 (98)	4.29 (109)	1.22 (31)	0.47 (12)

Millimeters in Parentheses

PARTS LIST

Det. No.	No. Req'd.	Part Name	NVSA 4224	NVSA 4234	NVSA 4244
1	1	Valve Body			
2	1	Detent assembly	DA0201	DA0201	DA0401
3A	2	#10-32 plug and gasket	NX7015-34	NX7015-34	NX7015-34
3B	2	#10-32 to 1/8" I.D. tube barb	211-1	211-1	211-1
4A	1	Gasket—pilot cover—"B" and	X7024-2A	X7027-3	X7029-2
4B	1	Gasket—pilot cover—"B" and	X7024-3B	X7027-3	X7029-2
5	1	Gasket—junction box cover	NX7015-9	XT015-12-2	NX7030-15
6	4	Captive screw—blank junction box cover	NX7015-11	NX7010-11	NX7010-11
7	1	Blank junction box cover assembly. Consists of detail 8 and (4) detail 8			
8	1	Blank junction box cover			
9	1	Sleeve assembly—			
10	6	O-ring—sleeve	APPM8-018	APPM8-018	APPM8-119
11	1	Spacer	AXT330-5-18	AXT340-5-1A	X1020-6
12	2	Pilot cover assembly with manual operator and junction box pilot connection. Consists of detail 13A, 3B, 15, (4) detail 14, and (4) 1/8" NPTF flush plugs.			
12A	2	Pilot cover assembly with manual operator but no junction box pilot connection. Consists of detail 15, (4) detail 14, (2) 1/8" NPTF flush plugs, and either detail 13C or details 13A and 3A.			
12C	1	Pilot cover assembly—"B" and—with manual operator and junction box pilot connection. Consists of detail 13B, 15, (4) detail 14, and (4) 1/8" NPTF flush plugs.			
13A	2	Pilot cover with #10-32 junction box pilot connection.	NX7015-1	NX7025-1	NX7035-1
13B	2	Pilot cover with 1/8" tube barb permanently bonded in cover for junction box pilot connection.	NX7015-1C		
13C	2	Pilot cover without junction box pilot connection.	NX7015B	NX7035-1B	NX7035-1B
14	6	Captive screw—Pilot cover	XT012-258	XT012-258	XT012-258
15	2	Recessed non-locking operator assembly with O-ring seal	FR0102	FR0102	FR0402
17	1	Gasket—valve body to sub-plate	NX7015-14	X7015-3	X7021-8
18	4**	Hold-down bolt and lockwasher	NX7015-18 (#10-24x3/4)	NX7030-14 (#14-20x3/4)	NX7030-13 (#14-20x1")
19	1	Tapped junction box cover assembly. Consists of detail 20 and (4) detail 21			
20	1	Tapped junction box cover			
21	4	Captive screw—tapped junction box cover	X7066-7	X7066-7	NX7013-3
22	2	Pilot cover assembly with no operator but with junction box pilot connection. Consists of details 13A, 3B, 23, (4) detail 14 and (4) 1/8" NPTF flush plugs.			
22A	1	Pilot cover assembly with no operator but with junction box pilot connection. Consists of details 13B, 23, (4) detail 14 and (4) 1/8" NPTF flush plugs.			
22B	2	Pilot cover assembly with no operator and with no junction box pilot connection. Consists of detail 13C, 23, (4) detail 14 and (2) 1/8" NPTF flush plugs.			
23	2	Plug for operator mounting hole.	B2301-14	B2301-14	B2301-14

*NVSA 4224 valves use only one of these on the "A" end of valve

**NVSA 4224 valves require only three hold-down bolts

SERIES
NVSA 4 24, 4 34
NVSA 4 44

DIRECTIONAL AIR VALVE
DIMENSIONS/PARTS LIST

NVSA 4324 NVSA 4424
4334 4434
4444 4444

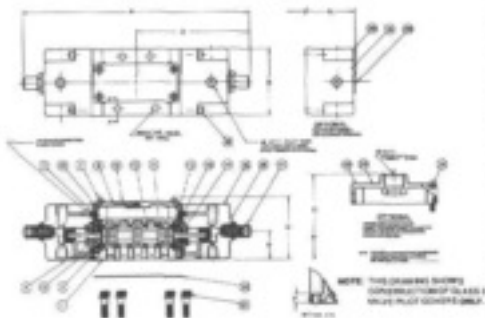

DIMENSIONS

Valve Size	A	A ₁	B	C	C ₁	D	E	F
NVSA 4324	6.26 (210)	6.77 (172)	2.13 (54)	2.36 (60)	9.27 (235)	3.23 (82)	1.06 (27)	0.35 (9)
NVSA 4334	8.62 (224)	7.32 (186)	2.52 (64)	2.44 (62)	3.31 (84)	3.58 (91)	1.06 (27)	0.39 (10)
NVSA 4344	11.05 (280)	9.84 (250)	2.83 (72)	2.99 (76)	3.86 (98)	4.29 (109)	1.22 (31)	0.47 (12)

Millimeters in Parentheses

PARTS LIST

Del. No.	No. Req'd.	Part Name	NVSA 4324	NVSA 4334	NVSA 4344	NVSA 4424	NVSA 4434	NVSA 4444
1	1	Valve Body						
2	2	O-ring—pilot passage	834H-P2	834H-P2	834H-P2	834H-P2	834H-P2	834H-P2
3	2	O-ring—pilot cover	834H-P22-A	834H-P22-A	834H-P21	834H-P22-A	834H-P22-A	834H-P21
4	2	Spring seal	AX7066-1	AX7066-1	A2633-1	AX7066-1	AX7066-1	A2153-1
5A	2	#10-32 plug and gasket	NX7015-34	NX7015-34	NX7015-34	NX7015-34	NX7015-34	NX7015-34
5B	2	#10-32 to 1/8" I.D. Tube barb	211-1	211-1	211-1	211-1	211-1	211-1
6	1	Gasket—junction box cover	NX7015-12	X7015-12	NX7015-12	NX7015-12	X7015-12	NX7015-12
7	4	Caprice screw—blank junction box cover	NX7015-11	NX7015-11	NX7015-11	NX7015-11	NX7015-11	NX7015-11
8	1	Blank junction box cover assembly. Consists of details 8 and 10 detail 7.						
9	1	Blank junction box cover						
10	1	Steele Assembly—						
11	6	O-ring—seals	APP566-018	APP566-018	APP566-118	APP566-018	APP566-018	APP566-118
12	1	Spacer—"A" End	AX7066-1	AX7066-1	A2153-1	AX7066-1	AX7066-1	A2153-1
13A	1	Spacer—"B" End	AX7066-2	AX7066-2	A2153-2	AX7066-2	AX7066-2	A2153-2
13	2	O-ring—spacer	AX7066-22	834H-P24	APP566-120	A3666-022	834H-P24	APP566-120
14	3	Spring—floor clamping	AX7066-1	AX7066-1	A2633-1	AX7066-1	AX7066-1	A2633-1
15	2	Pilot cover assembly—no operator and with junction box pilot connection. Consists of details 15, 17, 5B, 16 detail 18 and 16 1/8" NPTF flush plug						
15A	2	Pilot cover assembly with operator but without junction box pilot connection. Consists of details 15A, 17, 14 detail 18 and 1/8" NPTF flush plug						
16	2	Pilot cover with #10-32 junction box pilot connection						
16A	2	Pilot cover without junction box pilot connection						
17	3	Recessed non-rotating operator with O-ring seal	FR1000	FR1000	FR1000	FR1000	FR1000	FR1000
18	6	Caprice screw—pilot cover	X7015-258	X7015-258	X7015-258	X7015-258	X7015-258	X7015-258
19	1	Gasket—valve body to sub-plate	NX7015-14	X7015-14	X7015-14	NX7015-14	X7015-14	X7015-14
20	4	Washers—top and bottom	NX7015-13	NX7015-13	NX7015-13	NX7015-13	NX7015-13	NX7015-13
21	4	Tapered junction box cover assembly. Consists of detail 21 and 16 detail 24						
22	1	Tapered junction box cover						
23	4	Caprice screw—tapped junction box cover	X7066-7	X7066-7	NX7015-5	X7066-7	X7066-7	X7015-3
24	3	Pilot cover assembly—no operator and with junction box pilot connection. Consists of details 24, 26, 18, 16 detail 18 and 1/8" NPTF flush plug						
24A	2	Pilot cover assembly without operator and without junction box pilot connection. Consists of details 24A, 26, 16 detail 18 and 1/8" NPTF flush plug						
25	2	Plug for operator missing hole	B2301-14	B2301-14	B2301-14	B2301-14	B2301-14	B2301-14

*NVSA 4324/4334—Use 1 only on "A" End. Use AX7066-22 on "B" End. **NVSA 4324 models only require three hole-down bolts.

NVSA 4524
4534
4544

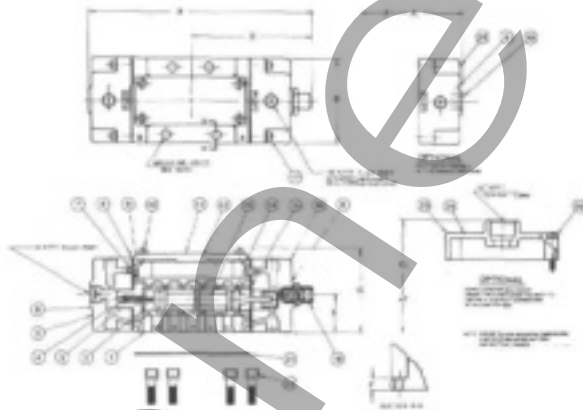

DIMENSIONS

Valve Size	A	A ₁	B	C	C ₁	D	E	F
NVSA 4524	5.98 (152)	5.43 (138)	2.13 (54)	2.36 (60)	3.27 (83)	3.23 (82)	1.06 (27)	0.35 (9)
NVSA 4534	6.85 (169)	5.93 (150)	2.52 (64)	2.44 (62)	3.31 (84)	3.58 (91)	1.06 (27)	0.39 (10)
NVSA 4544	8.75 (207)	7.46 (188)	2.83 (72)	2.99 (76)	3.86 (98)	4.29 (109)	1.22 (31)	0.47 (12)

Millimeters in Parentheses

PARTS LIST

Del. No.	No. Req'd.	Part Name	NVSA 4524	NVSA 4534	NVSA 4544
1	1	Valve Body			
2	2	Button—"B" End	AX7366-10-2	AX7366-10-2	X7366-14
3	2	Spring seal	NX7015-32	NX7015-32	AX7066-1
4	2	Spring—speed return	X7366-18	X7366-18	X7366-18A
5A	1	Pilot cover assembly—"B" and with junction box pilot connection but no operator. Consists of details 5, 18, 16, 16 detail 17 and 1/8" NPTF flush plug			
5B	1	Pilot cover assembly—"B" and with junction box pilot connection but no operator. Consists of details 5A, 18, 16 detail 17, and 1/8" NPTF flush plug			
5C	1	Pilot cover assembly—"B" and no operator—no junction box pilot connection. Consists of details 5B, 18, 16 detail 17 and 1/8" NPTF flush plug			
6	2	Pilot cover with #10-32 junction box pilot connection			
6A	1	Pilot cover with 1/8" tube barb permanently bonded in cover for junction box pilot connection			
6B	2	Pilot cover without junction box pilot connection			
7A	2	#10-32 plug and gasket	NX7015-34	NX7015-34	NX7015-34
7B	2	#10-32 to 1/8" I.D. tube barb with gasket	211-1	211-1	211-1
8A	1	Gasket—pilot cover—"A" end	X7015-34	X7015-34	X7015-34
8B	1	Gasket—pilot cover—"B" end	X7015-38	X7015-38	X7015-38
9	4	Gasket—junction box cover	NX7015-10	X7015-10-2	NX7015-10
10	4	Caprice screw—blank junction box cover	NX7015-11	NX7015-11	NX7015-11
11	1	Blank junction box cover assembly. Consists of detail 11 and 16 detail 10.			
12	1	Blank junction box cover			
13	1	Steele assembly—			
14	6	O-ring—seals	APP566-018	APP566-018	APP566-118
15	1	Spacer	AX7366-18	AX7366-18	X7366-14
16	1	Pilot cover assembly—"A" and with operator and junction box pilot connection. Consists of details 6, 7B, 16 detail 17 and 1/8" NPTF flush plug			
16A	1	Pilot cover assembly—"A" and without operator and without junction box pilot connection. Consists of details 6A, 18, 16 detail 17 and 1/8" NPTF flush plug			
17	6	Caprice screw—pilot cover	X7015-258	X7015-258	X7015-258
18	1	Plug for operator missing hole	B2301-14	B2301-14	B2301-14
21	1	Gasket—valve body to sub-plate	NX7015-14	X7015-14	X7015-14
22	4	Washers—top and bottom	NX7015-13	NX7015-13	X7015-13
23	1	Tapered junction box cover assembly. Consists of detail 23 and 16 detail 25			
24	1	Tapered junction box cover			
25	4	Caprice screw—tapped junction box cover	X7066-7	X7066-7	NX7015-3
26	1	Pilot cover assembly—"A" and without operator and without junction box pilot connection. Consists of details 6B, 18, 16 detail 17 and 1/8" NPTF flush plug			
26A	1	Pilot cover assembly—"A" and without operator but with junction box pilot connection. Consists of details 6, 18, 16 detail 17 and 1/8" NPTF flush plug			

**NVSA 4524 models require only three hole-down bolts.

DIRECTIONAL AIR VALVE SUBPLATES

SERIES
NVSA 4 24, 4 34
NVSA 4 44

NVSA 4 24

General:

Sub-plates are heavy duty aluminum die castings. All ports are marked with identification in accordance with American National Standards Institute standard ANSI B93.9-1969 "Symbols for Marking Electrical Leads and Ports on Fluid Power Valves."

Standard sub-plates do not provide for pilot pressure connections through the sub-plate.

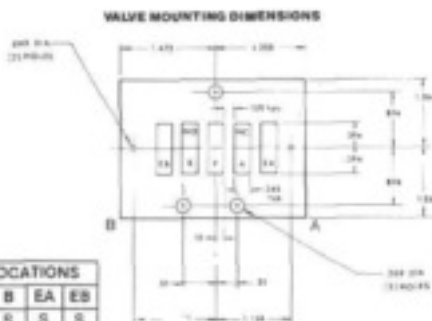

SUB-PLATE MODEL NO.	N ₁ N ₂ F	PORT LOCATIONS					
		P	A	B	EA	EB	
SPC201	1/4	S	S	S	S	S	
SPC202	3/8	S	S	S	S	S	
SPC203	1/4	B	B	B	B	B	
SPC206	1/4	S/B	B	B	B	B	
SPA201	1/4	S	S	S	S	S	
SPA202	3/8	S	S	S	S	S	

S = SIDE
B = BOTTOM
S/B = SIDE & BOTTOM

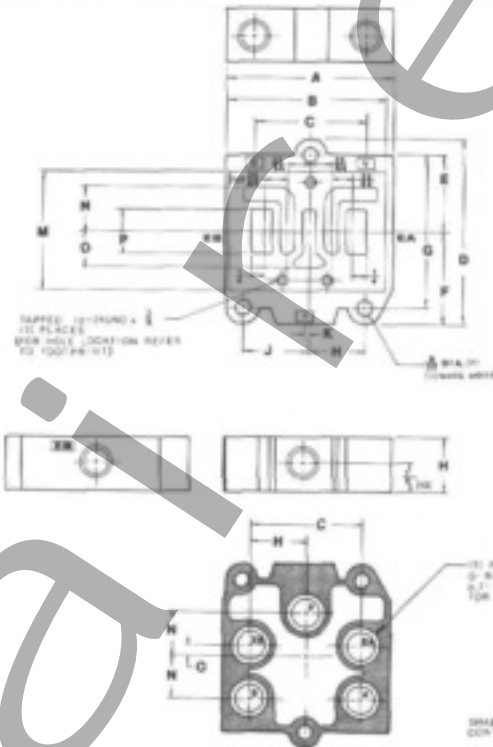

A	B	C	D	E	F	G	H	J	K	M	N	O	P	Q	R	S	T	U	V	W	X	Y	Z	
4.75	4.68	3.05	3.21	1.28	1.40	2.75	0.86	1.18	0.88	2.12	0.76	0.62	0.75	0.62	0.62	0.62	0.62	0.62	0.62	0.62	0.62	0.62	0.62	0.62

Dimensions in Parentheses

NVSA 4 34

General:

Sub-plates are heavy duty aluminum die castings. All ports are marked with identification in accordance with American National Standards Institute standard ANSI B93.9-1969 "Symbols for Marking Electrical Leads and Ports on Fluid Power Valves."

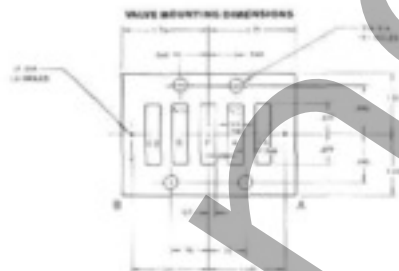

SUB-PLATE MODEL NO.	N ₁ N ₂ F	PORT LOCATIONS					
		P	A	B	EA	EB	
SP0301	3/8	S	S	S	S	S	
SP0302	1/2	S	S	S	S	S	
SP0303	3/8	S/B	S/B	S/B	S/B	S/B	
SPA302	1/2	S	S	S	S	S	

S = SIDE
B = BOTTOM
S/B = SIDE & BOTTOM

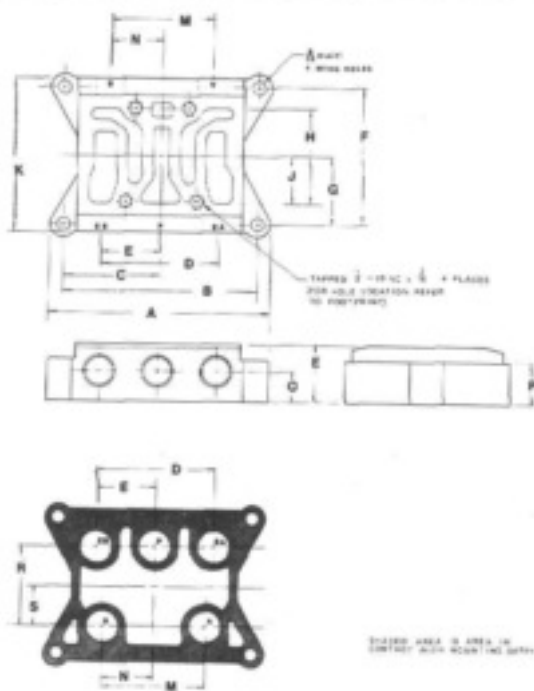

A	B	C	D	E	F	G	H	J	K	M	N	O	P	Q	R	S	T	U	V	W	X	Y	Z
4.75	4.68	3.05	3.21	1.28	1.40	2.75	0.86	1.18	0.88	2.12	0.76	0.62	0.75	0.62	0.62	0.62	0.62	0.62	0.62	0.62	0.62	0.62	0.62

Dimensions in Parentheses

SERIES
NVSA 4 24, 4 34
NVSA 4 44

DIRECTIONAL AIR VALVE
SUBPLATES

NVSA 4 44

General:

Sub-plates are heavy duty aluminum die castings. All ports are marked with identification in accordance with American National Standards Institute standard B93.9-1969 "Symbols for Marking Electrical Leads and Ports on Fluid Power Valves."

Pilot Connections in Sub-Plate:

All models have two 1/8" NPTF pilot ports in the ends of the sub-plate which interconnect with pilot passages in the mounting surface of NVSA valves.

Refer SP0403, 0404. All side and bottom port sub-plates are shipped with (5) loose socket head flush pipe plugs to plug the unused ports.

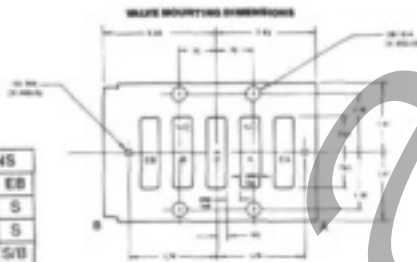
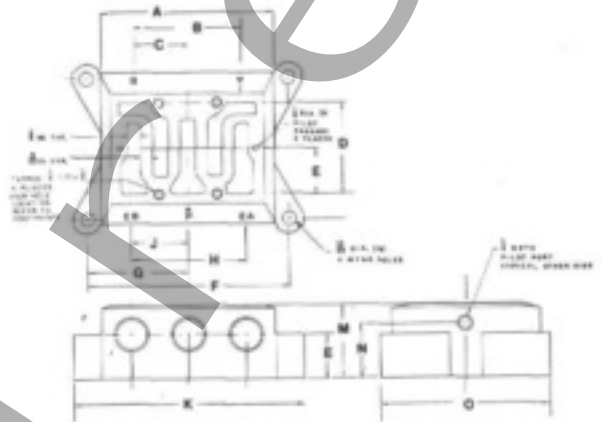

SUB-PLATE MODEL NO.	N _v P _v	PORT LOCATIONS				
		P	A	B	EA	EB
SP0401	1/2	S	S	S	S	S
SP0402	3/4	S	S	S	S	S
SP0403	1/2	S/B	S/B	S/B	S/B	S/B
SP0404	3/4	S/B	S/B	S/B	S/B	S/B

S = SIDE
B = BOTTOM
S/B = SIDE & BOTTOM

A	B	C	D	E	F	G	H	J	K	M	N	O	P	R	T
1.40	2.75	1.50	2.50	1.10	2.04	2.00	2.00	1.50	2.00	2.07	1.50	4.07	2.00	1.50	2.07
35.4	70.0	38.1	63.5	27.9	51.8	50.8	50.8	38.1	50.8	52.1	38.1	103.0	50.8	38.1	52.1

Millimeters in Parentheses

NVSA 4 44 (1")

General:

Sub-plates are heavy duty aluminum die castings. All ports are marked with identification in accordance with American National Standards Institute standard B93.9-1969 "Symbols for Marking Electrical Leads and Ports on Fluid Power Valves."

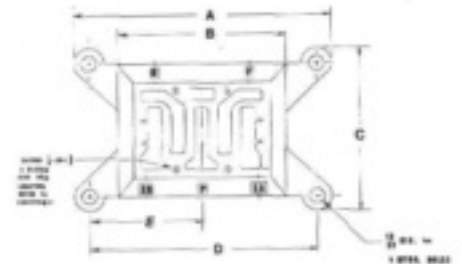

VALVE MOUNTING DIMENSIONS

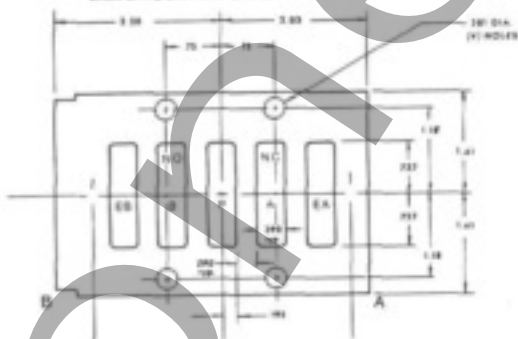

SUB-PLATE MODEL NO.	N _v P _v	PORT LOCATIONS				
		P	A	B	EA	EB
SP0502	1	S	S	S	S	S

S = SIDE

A	B	C	D	E	F	G	H	J	K	M	N	O
1.50	4.00	2.40	2.27	2.27	2.40	1.27	1.10	2.50	2.20	1.10	2.70	1.50
38.1	101.6	61.0	57.7	57.7	61.0	32.3	27.9	63.5	55.9	27.9	68.6	38.1

Millimeters in Parentheses

SERIES
NVSA 4024, 4034
NVSA 4044

**DIRECTIONAL AIR VALVE
INTERFACE SPEED CONTROL
PORT RELOCATION BLOCK**

GENERAL

This Speed Control is an Aluminum die cast Interface Plate having on its upper surface a mounting pattern which accepts SMC NVS 4024 or NVS 4034 solenoid operated valves and with a lower surface which mounts onto all subplates and manifolds applicable to these valves.

INSTALLATION

This Speed Control is mounted between the subplate/manifold and the valve by utilizing 1" longer bolts in place of the standard valve Hold Down bolts. May be field installed without system or piping modifications.

NVSA4024

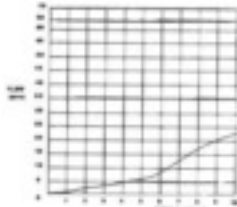
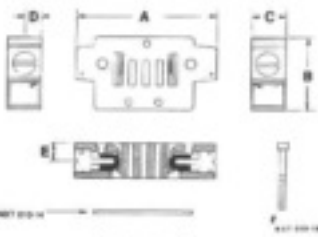

TO ORDER FOR FIELD REPLACEMENT
Kit Number **SP 0200** Comprising
1 - # AXT 394 Speed Control Block
1 - # NXT 010-14 Gasket
3 - # NXT 010-16-1 Hold Down Bolts (10-24 x 1 1/4")

DIMENSIONS

A	B	C	D	E
4.01	2.13	0.98	0.47	0.31
(102)	(54)	(25)	(12)	(8)

Millimeters in Parentheses

Optional

SPA0200 Interface speed control w/crossover pilot holes to connect with sub-plate.

TO ORDER AS PART OF VALVE/MANIFOLD ASS'Y

ADD Suffix "M" to part number.
Example: Part # NVS4124-0200M-ANVS 4124-0000 mounted on a #SP0202 subplate with #SP0200 Interface speed control between.

FEATURES

1. Eliminates expense of "External" Flow Controls and necessary piping.
2. Simplifies installation by eliminating piping.
3. Provides for "Bleed-Out" flow adjustments from Zero to 90% of valves Full Flow capacity.
4. Improves system appearance.

OPERATION

Cylinder speeds may be independently controlled by adjustment of the needle valves in the "EA" & "EB" ports of the speed control block. These needle valves control flows of exhaust air from the valve and are "Vibrationproof" and of "Non-Rising" design.

NVSA4034

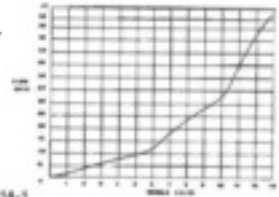

TO ORDER FOR FIELD REPLACEMENT
Kit Number **SP 0300** Comprising
1 - # AXT 393 Speed Control Block
1 - # XT 016-3 Gasket
4 - # NXT 020-14-1 Hold Down Bolts (# 1/4-20 x 1 1/4")

DIMENSIONS

A	B	C	D	E
4.41	2.68	0.98	0.47	0.31
(112)	(68)	(25)	(12)	(8)

Millimeters in Parentheses

Optional

SPA0300 Interface speed control w/crossover pilot holes to connect with sub-plate.

TO ORDER AS PART OF VALVE/MANIFOLD ASS'Y

ADD Suffix "M" to part number.
Example: Part Number # NVS 4134-0200M = A # NVS 4134-0000 valve mounted on # SP 0302 subplate with # SP 0300 Interface Speed Control between.

PORT RELOCATION BLOCK

The cylinder port relocation block is an aluminum die cast sandwich plate which mounts between the valve unit and the sub-plate.

It provides two sets of cylinder ports emerging at right angles to the supply port (out under the ends of the valve.)

This useful accessory can be used to ease piping problems in those tight places where there is simply no room for piping out the normal cylinder ports in the sub-plate.

It also provides additional cylinder ports for those situations where the valve serves more than one cylinder, or where pressure indicators must be mounted in the on-going cylinder lines.

Note: Each cylinder port relocation block is shipped complete with the necessary extra-long hold-down bolts, one sub-plate gasket, and two flush pipe plugs to plug the unused cylinder ports in the block.

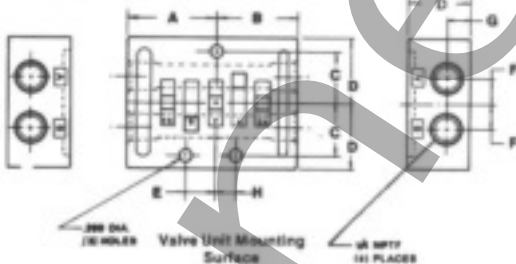

ORDERING PART NO. SP 0205
(1/4" NPTF PORTS)

INCLUDES
1 Block XT 015-2
3 Soc Hd Screws NXT 010-19A (10-24x1 1/4")
1 Gasket NXT 010-14
2 Flush Plugs 1/4" NPT

Foot Print of Port Relocation Block Mounting Surface

DIMENSIONS

A	B	C	D	E	F	G	H
1.47	1.36	0.874	1.10	0.51	0.433	0.42	0.31
(37)	(34.5)	(22.2)	(27.9)	(12.9)	(10.9)	(10.7)	(7.9)

Millimeters in Parentheses

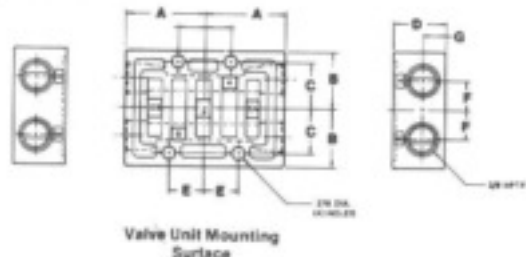

ORDERING PART NO. SP 0304
(3/8" NPTF PORTS)

INCLUDES
1—Block XT 016-2
4—Soc Hd Screws NXT 020-10 (1/4-20x2")
2—Flush Plugs 3/8" NPT

Foot Print of Port Relocation Block Mounting Surface

DIMENSIONS

A	B	C	D	E	F	G	H
1.75	1.25	0.995	1.14	0.75	0.63	0.47	0.56
(44.4)	(31.7)	(25.3)	(28.9)	(19.1)	(16.0)	(1.19)	(14.2)

Millimeters in Parentheses

**DIRECTIONAL AIR VALVE
MANIFOLD ASSEMBLY**

SERIES
NVSA 424, 434
NVSA 444

GENERAL

In addition to mounting on individual subplates, All SMC NVSA 4024 & 4034 Valves may be "Close-Mounted" on "Stacking" manifold assemblies. If required, Solenoid, Solenoid/Pilot Operated and Air piloted valves may be intermixed, without modification, on any given valve manifold. This arrangement greatly reduces space requirements and simplifies piping layouts. A common Pressure Gallery (P) and two common Exhaust Galleries (EA & EB) interconnect with the pressure and exhaust ports of all the valves within the assembly. Pressure and Exhaust service connections are located at either end of the manifold. Pilot Air ports (PA & PB) are also standard on all manifold blocks to allow Air Piloted valves, mounted on the manifold, to be operated by means of pilot air supplied through the manifold's pilot air supply ports.

CONSTRUCTION

Each of the manifold blocks and the manifold End Plates are affixed to its adjacent block by a unique pair of "V" Clamp Plates held together by two bolts and nuts. Additional blocks may be added to an existing manifold assembly, without modification of the assembly or having to disturb the piping other than the Pressure and Exhaust service connections.

**TO SPECIFY "FACTORY BUILT"
VALVE/MANIFOLD ASSEMBLY**

1. Establish the number of stations required.
2. Select the type and size of valve required at each station.
3. Choose Manifold Block porting desired.
4. To specify a Valve mounted on a manifold block—Insert manifold block number into valve number, e.g. #NVSA4124-2109D is a NVSA4124-0009D valve mounted on a #21 Manifold Block.

**TO ORDER "FACTORY BUILT"
VALVE/MANIFOLD ASSEMBLY**

Example 1 Pcs. Five Station Manifold Ass'y comprising:
Station 1. NVS 4124-2109D
Station 2. NVS 4234-3109D
Station 3. NVS 4434-3109D
Station 4. NVSA 4124-41N
Station 5. NVSA 4234-36N
1 Pcs. ME 403LR -- 5 Assembly Kit.

TO ORDER INDIVIDUAL COMPONENTS:

Ref. No.	Part No.	Pcs. Req.	Description
1A	MB 4020-03	—	#21 Manifold Block
1B	MB 4020-04	—	#41 Manifold Block
1C	MB 4021-03	—	#23 Manifold Block
1D	ME 4022-03	—	#28 Manifold Block
1E	MB 4030-03	—	#31 Manifold Block
1F	MB 4030-04	—	#51 Manifold Block
1G	MB 4031-03	—	#33 Manifold Block
1H	MB 4232-03	—	#38 Manifold Block

Note: Use for mounting NVS 4024 valves. (Includes (1) Ref. 5, (4) Ref. 7, (1) Ref. 8).

Note: Use for mounting NVS 4034 valves.

Note: All above Manifold Blocks include (2) Ref. 4, (2) Ref. 5, and (3) Ref. 9.

Ref. No.	Part No.	Qty.	Description
2 & 3	ME 403 LR	1	Right & Left End Blocks, Incl. (2) Ref. 4, (2) Ref. 5 and (3) Ref. 9.
4	AXT 228-3	2	Top or Bottom "V" Clamp Plates.
5	MB x 60	2	Bolt and nut for "V" Clamp Plates.
6	MA 403-2	—	4024 to 4034 mounting Adapter Plate.
7	NXT 030-14A	4	Bolts, Adaptor Plates, 1/4-20x5/8.
8	NXT 016-3-1	1	Gasket, Adaptor Plate.
9	P 20	3	O Ring, Manifold Block galleries.
10	AXT 228-4A	—	Blocking Disc, Gallery.
11	NXT 015-17-4	2	Pin, Manifold Block alignment. Necessary for assemblies over four (4) valves.

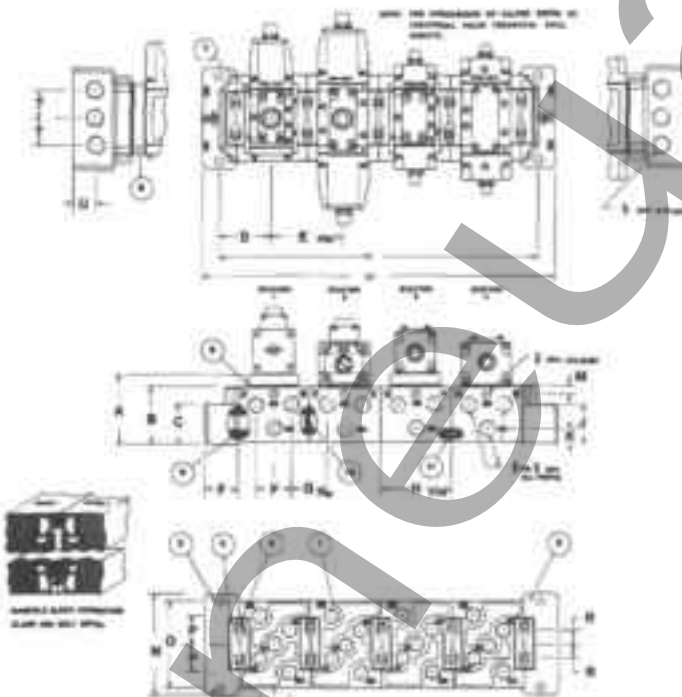

Manifold Dimensions

No. of Stations	L ₁	L ₂
2	8.83 (224)	16.58 (420)
3	12.36 (314)	14.59 (369)
4	15.81 (403)	17.84 (453)
5	19.45 (494)	21.18 (538)
6	22.96 (584)	24.73 (628)
7	26.54 (674)	28.27 (718)
8	30.26 (764)	31.81 (808)

Millimeters in Parentheses

DIMENSIONS

A	B	C	D	E	F	G	H	J	K	M	N	O	P	R	S	T	U
3.43	2.83	1.89	2.64	3.54	1.73	1.81	3.54	1.97	0.79	0.35	5.12	4.33	1.38	0.67	0.71	1.34	1.18
(87)	(72)	(48)	(67)	(90)	(44)	(46)	(90)	(50)	(20)	(9)	(130)	(110)	(35)	(17)	(18)	(34)	(30)

Millimeters in Parentheses

SERIES
NVSA 4024, 4034
NVSA 4044

SOLENOID AND AIR PILOTS CAN BE INTERCHANGED

Due to the modular design of the Series NVS/NVSA 4024 through 4044 valves, interchanging solenoids and air pilot operators on either the "A" or "B" ends of the valves is possible.

This allows electrical operation of the valve in one direction and air pilot for the return. Contact the factory for further information.

BASIC CONSTRUCTION

SMC air pilot operated valves use the same basic body, spool and sleeve, and internal parts as the SMC solenoid valves. The end lands of the spool form their own pilot piston, allowing pilot air to act upon the end of the spool directly, and avoiding the need for any elastomer seals.

All Captive (Metric) Fasteners

All fasteners which hold the valve assembly together are standard metric fasteners, captive in their respective parts, to avoid loss during assembly and/or dis-assembly. Only the hold-down bolts are not captive, to allow the use of hold-down bolts appropriate to the sub-plate being used. (Most of these valves are interchangeable with competitive valves on the competitive sub-plates.)

These valves were designed to co-operate with air logic, and every effort has been made to maximize performance when used in conjunction with air logic.

Patented* Spool and Sleeve

*US Patent No. 3952775

The SMC patented spool and sleeve make an ideal valving action to co-operate with air logic. The lack of elastomer seals provides a uniform response from cycle to cycle with actuation occurring at a constant pilot pressure regardless of the pressures within the valve passages.

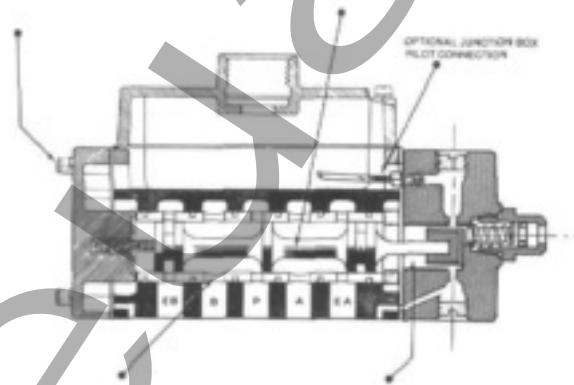

Patented* Differential Sleeve Porting

*US Patent No. 3952775

Provides a short stroke which minimizes spool hammer and promotes long bumper life.

NVSA 4524, 4534, 4544 Double Pilot Spring Offset

Where to Use It:

Application #1 — To increase spool and sleeve response.

Standard moving part logic output pressure is 50 PSIG (3.44 Bar). When pilot pressure builds up in the "A" pilot chamber, the spool shifts fully at about 10 PSIG (0.69 Bar). This produces a very fast response. After the valve has shifted, the pressure in the "A" pilot builds up to the full 50 PSIG.

When the logic system exhausts the "A" pilot, the pressure in the "A" pilot chamber must decay from 50 PSIG all the way down to below 10 PSIG before the spring can return the spool, a time-consuming process.

Pilot volumes have been held to a practical minimum. This, coupled with the extremely short spool stroke and low pilot pressure required for actuation, provides remarkably fast response to the incoming pilot signal.

If, at the same time the "A" pilot is exhausted, the "B" pilot is pressurized, then as the pressure in "A" pilot decays, the pressure in the "B" pilot builds up. When the pressure in the "B" pilot is within 10 PSI of that in the "A" pilot, the spring returns the spool. This action significantly reduces the time required to return the valve spool to the initial position.

Application #2 — To prevent shifting of the spool by pressurizing the "B" pilot.

If the "B" pilot is pressurized, pressurizing the "A" pilot has no effect. The spool does not shift. Thus, it is possible to interlock the action of the valve by pressurizing the "B" pilot to prevent the "A" pilot from actuating the valve.

SERIES
NVSA 4 24, 4 34
NVSA 4 44

**DIRECTIONAL AIR VALVE
PILOT OPTIONS**

PILOT OPTIONS AND FEATURES

Junction Box Pilot Connections

All sub-plate mounted models offer an optional set of #10-32 pilot ports within the junction box in the top of the valve body, and a large tapped junction box cover, which allows pilot tubing to be run into the valve through electrical conduit, Sealtite, or air hose as wires are run into the electrical valves. Push-on barbs for 1/16" I.D. pilot tubing are supplied installed in the pilot covers.

Multiple External Pilot Ports

All models carry four external pilot ports in the four sides of the pilot cap. These ports may be used or plugged, as desired. One popular use is to install a pressure indicator in one port to show whether pilot pressure is applied, similar to the function of electrical pilot lights on the solenoid valves.

Manual Operators

All models offer an optional recessed non-locking operator. This is a dust-tight splash-proof, air-tight unit which pushes directly on the end of the spool bumper to move the main spool directly. Because the operator is sealed and air-tight, the pilot pressure acts upon the inner end of the operator stem as though it were a piston, and in troubleshooting, you can press gently on the operator and tell whether there is pressure in that pilot chamber. All operators have their own return springs, and do not interfere with normal spool action when they are not in use.

Internal Pilot Ports in Gasket Face

All bodies provide internal 2 mm. pilot passages drilled out of the mounting face of the body, for use on sub-plates which provide pilot connections in the sub-plate.

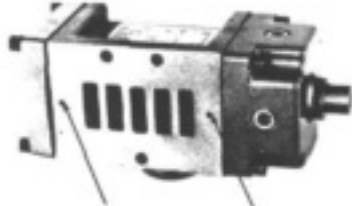
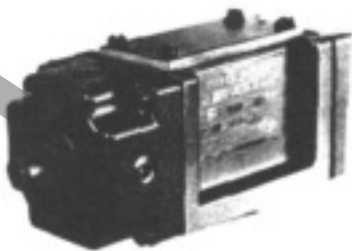

PILOT INDICATORS

These brass plugs when placed into the 1/8" Pilot Ports of an "A" or "B" style NVSA allow you to know if and when pressure is in the pilot cavity. You have an option of either a red or green rising pin on your indicator.

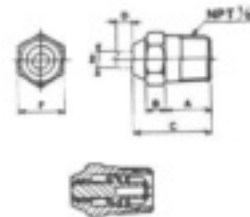

HOW TO ORDER

PART NO.	SUFFIX NO.	DESCRIPTION
VR 3110-01R	V1	Red "Pop Up" Indicator 1/8" NPTF
VR 3110-01G	V2	Green "Pop Up" Indicator 1/8" NPTF

DIMENSIONS

A	B	C	D	E	F
0.39	0.16	0.67	0.12	0.14	0.39
(10)	(4)	(17)	(3)	(3.5)	(10)

Millimeters in Parentheses

Example: NVSA 4124-52A V2