

# PC Wiring System

Series PCW

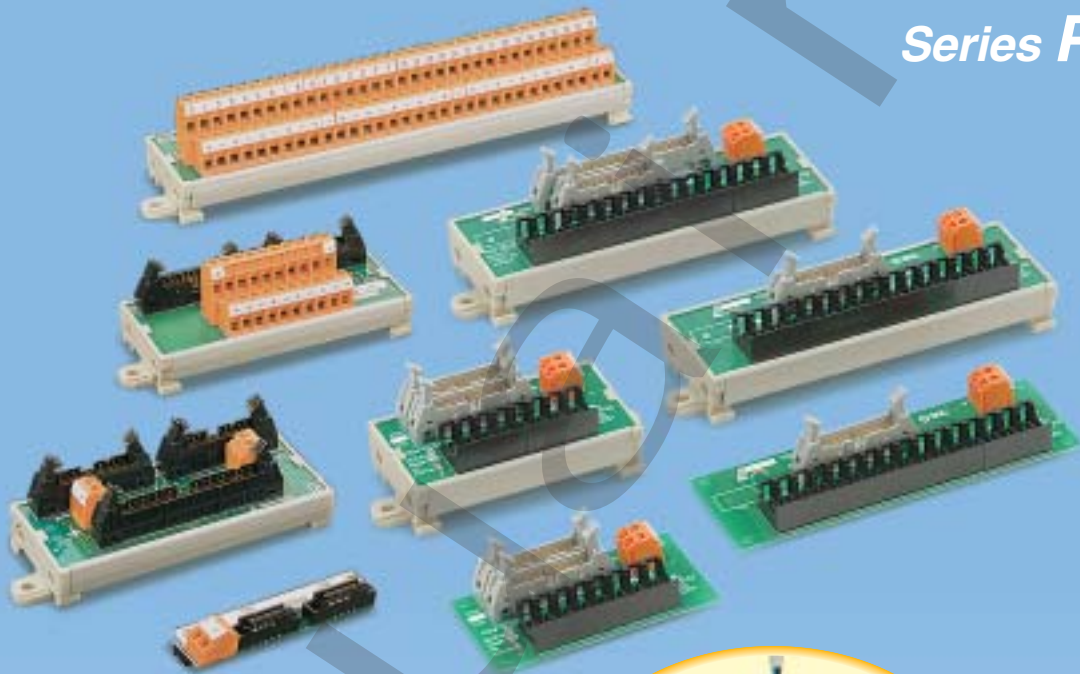

*e-con type is newly added!  
One-touch connection  
reduces wiring labor.*

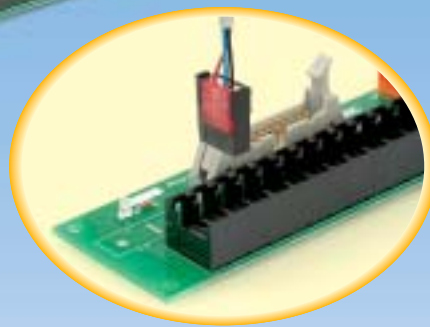

## Branch unit offers commonality

- Branch unit separates each manufacturer's 32 point Input/Output (I/O) into 16 point common pin layout.
- Conversion to a common pin layout, allows connection of the pin to P/A manifold solenoid valves and other manufacturers' relay terminals without restriction.
- Power can be supplied to the PLC I/O unit.
- Compatible branch units are available for each PLC manufacturer's I/O.

## Simple parallel wiring type

- Without time delay unlike serial transmission.
- Easy visual understanding at a glance, offering simple start-up, de-bug and trouble shooting maintenance.

## Improved wiring efficiency and ease of operation

- Dedicated cable reduces wiring-equivalent to a serial transmission system.
- One-touch type connector offers standardized wiring to prevent incorrect connection and vastly improved operational efficiency.

# A revolutionary new wiring system...

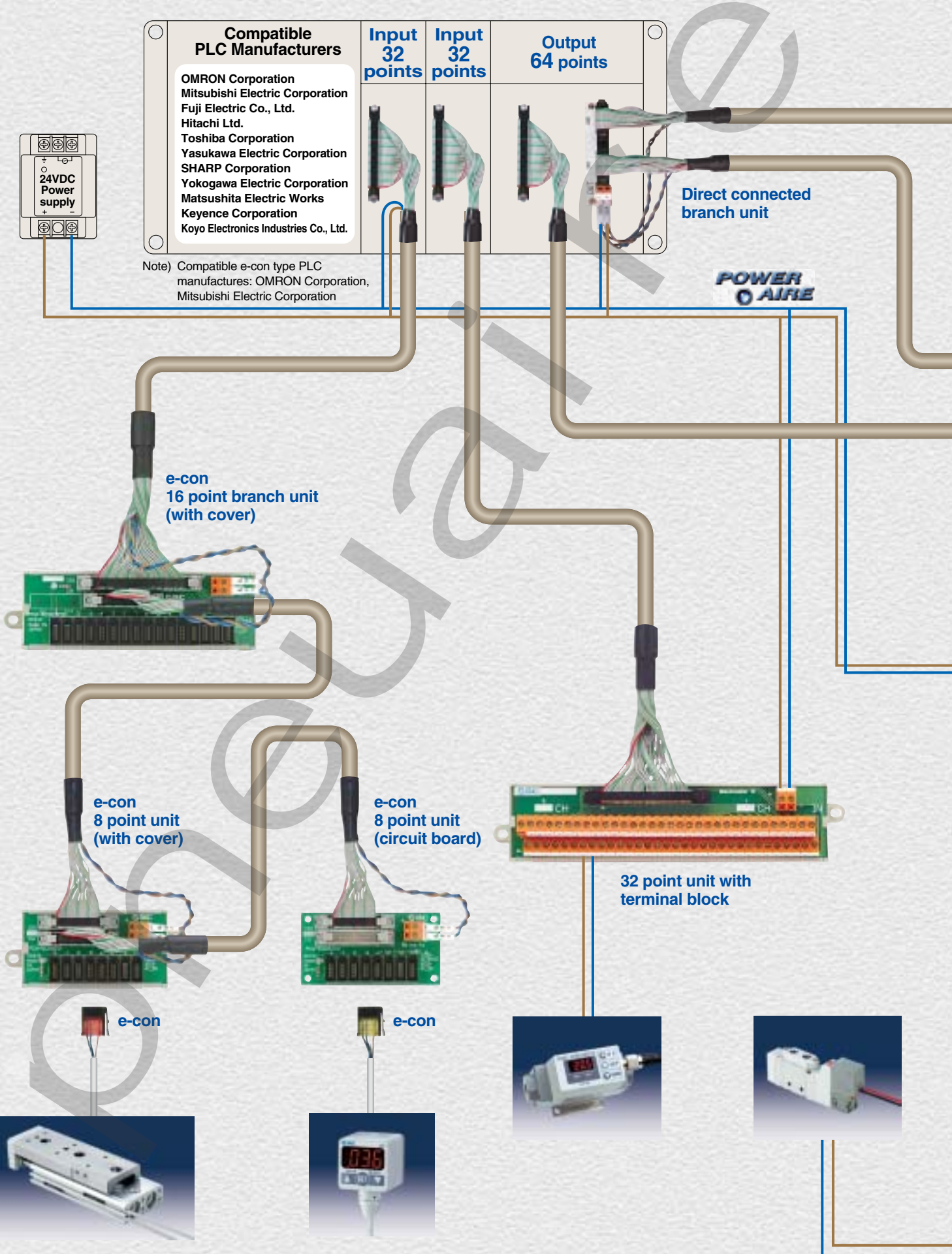

# The PC wiring system simplifies wiring between a PLC and all types of connected equipment.

## PC Wiring System *Series PCW*

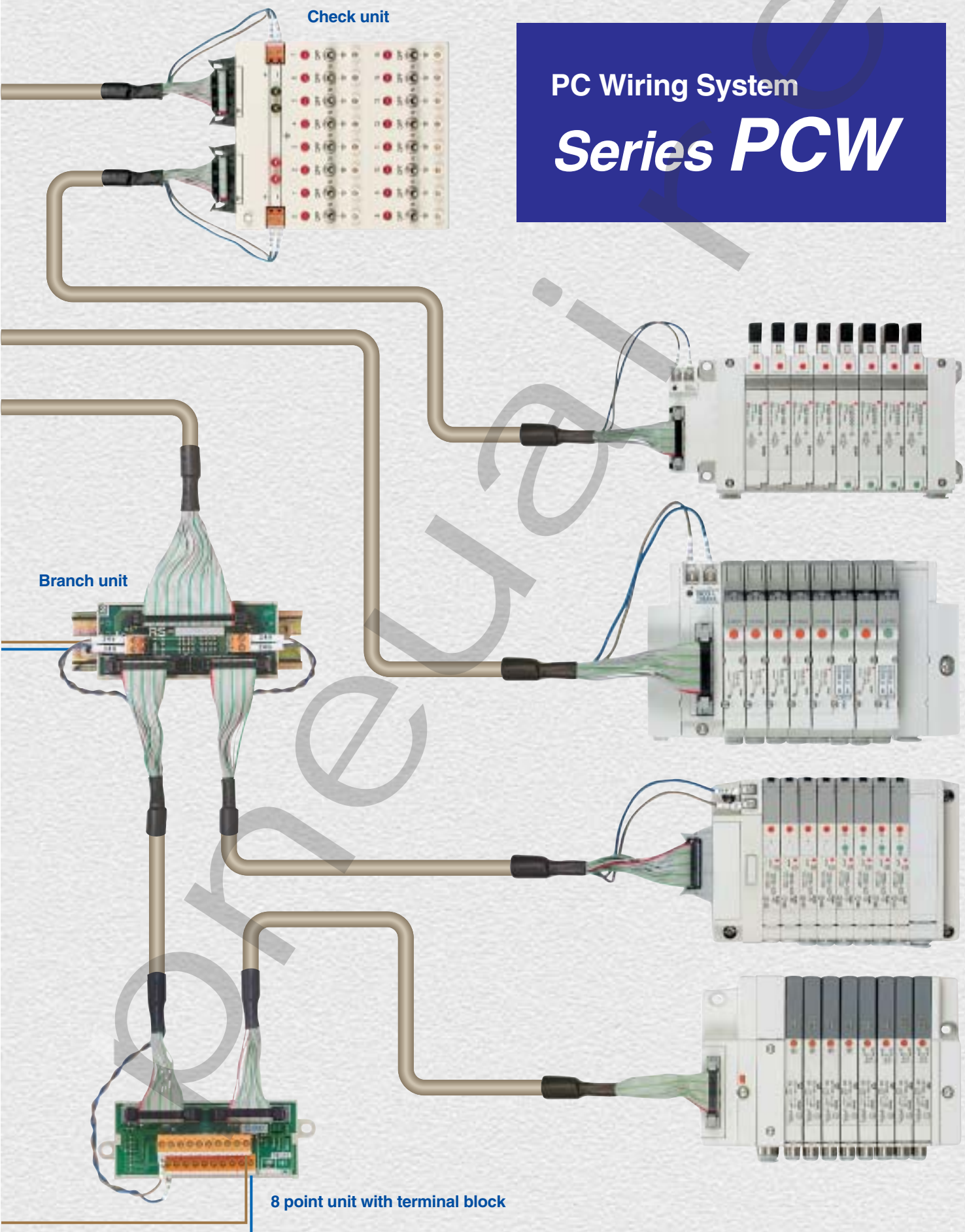

# Standardized pin layout

Once 32 point terminal block unit or branch unit is replaced, no further wiring/design is necessary.

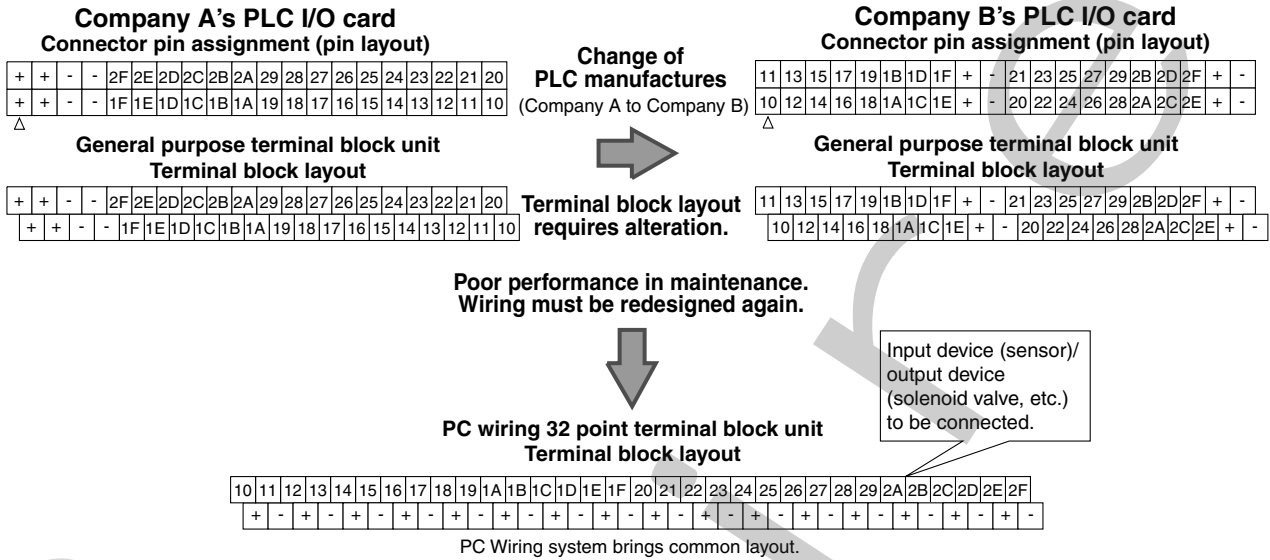

## Adoption of e-con type eliminates the need for special tools and wire stripping.

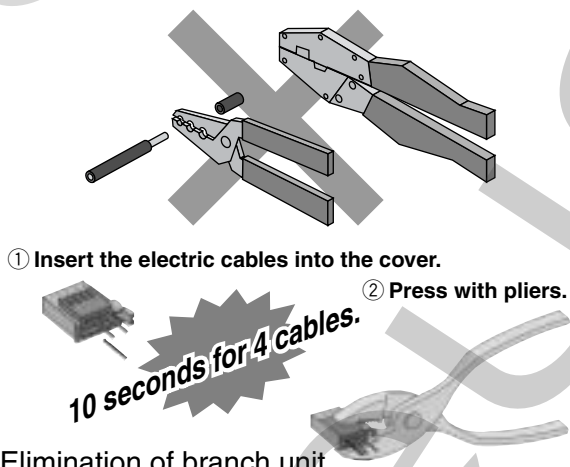

[Promoted or evaluated by]

Mitsubishi Electric Corporation, OMRON Corporation, Fuji Electric Co., Ltd.,  
Keyence Corporation, SUNX, Anywire Corporation, NKE, Kuroda Precision  
Industries Ltd., 3M, AMP, P/A

Common unit can be used.

Reduced spare parts enabling easier stock control.

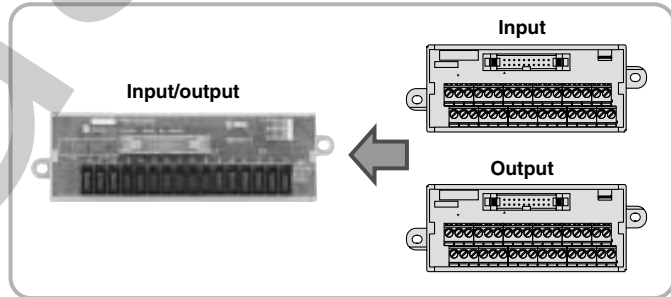

### Elimination of branch unit

The function of a branch unit is built-in a 16 point unit, allowing reduction of the number of units.

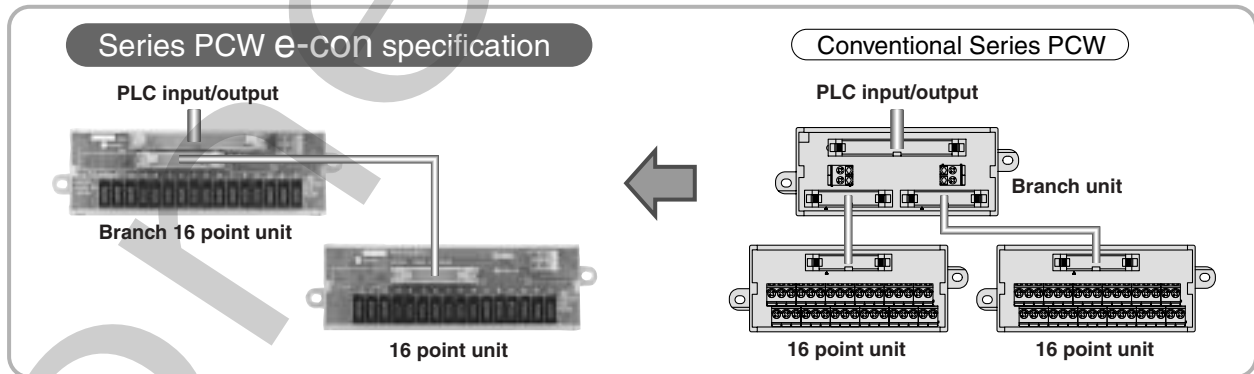

### Reverse connection detection function

Visual indication of incorrect wiring of power supply terminal block and power supply status is provided.

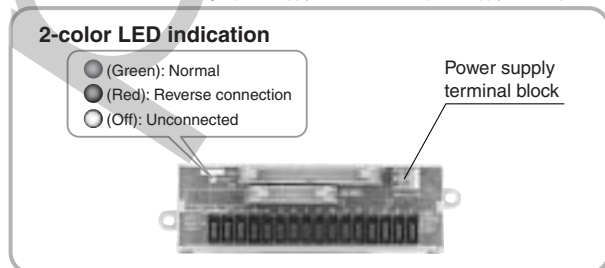

Each unit available with cover compatible with DIN rail mounting or as circuit board.

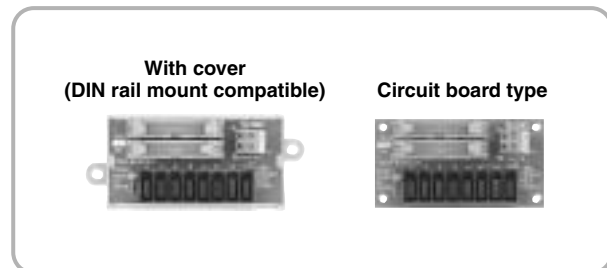

# PC Wiring / *Series PCW-EC* (e-con Type)

P.2

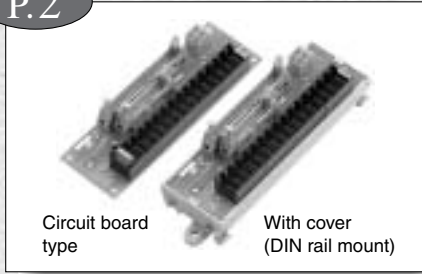

## 16 point branch I/O unit

Unit with e-con combines branch unit with 16 point unit.

P.5

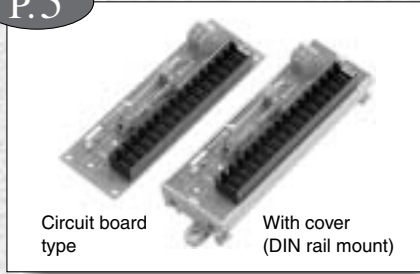

## 16 point I/O unit

16 point unit with e-con allows common models used for both I/O units.

P.6

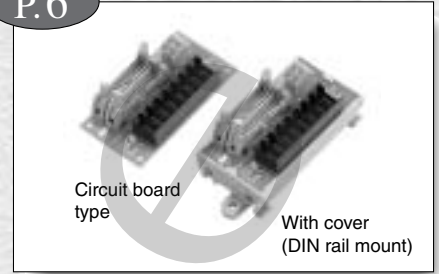

## 8 point I/O unit

8 point unit with e-con allows common models used for both I/O units. Can use two 8 point I/O units in a cascade connection.

# PC Wiring System / *Series PCW*

P.8

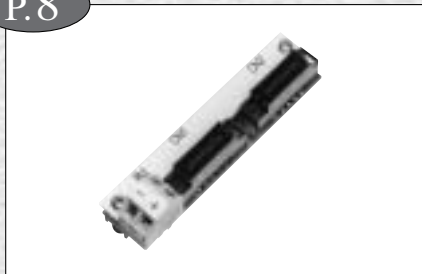

## Branch unit: PLC direct connected type

Directly mounted on PLC I/O card.

P.12

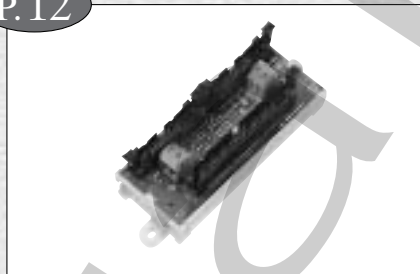

## Branch unit

Connected to PLC I/O card via connection cable.

P.44

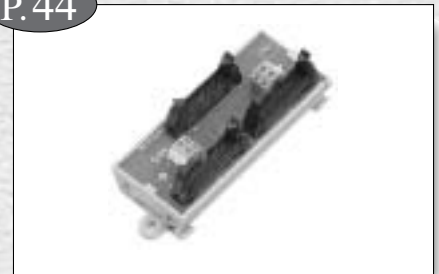

## 8 point branch unit

Separates two of 8 point I/O transmissions once those are separated from two of 16 point I/O by the branch unit.

P.24



## 32 point I/O unit

Wired to PLC I/O card via connection cable and wires connecting equipment to the terminal blocks.

P.36

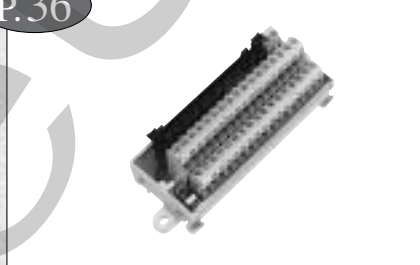

## 32 point output reduced common unit

Wired to PLC I/O card via connection cable and wires connecting equipment to the terminal blocks. Products with cross-over common wires are available.

P.43

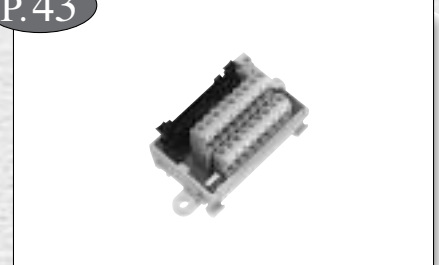

## 16 point output reduced common unit

Wires two of 16 point I/O signals once separated by the branch unit to each connecting equipment via terminal block. Products with cross-over common wires are available.

P.40

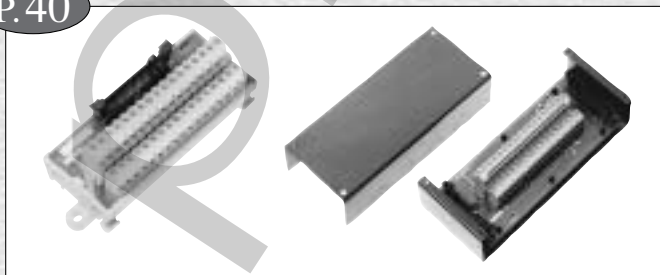

## 16 point I/O unit

Wires two of 16 point I/O signals once separated by the branch unit to each connecting equipment via terminal block. DIN rail mount type and box mount types are available.

P.45

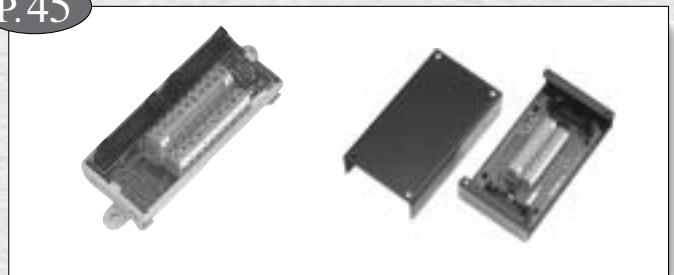

## 8 point I/O unit

Wires two of 16 point I/O signals once separated by the branch unit to each connecting equipment via terminal block. DIN rail mount type and box mount types are available.

# PC Wiring System e-con Type

# Series PCW-EC



## Common Specifications

Rated voltage		24 VDC
Rated current	Power supply line	2 A
	Communication line	0.3 A
Insulation resistance		5 MΩ or more at 100 VDC
Withstand voltage		500 VAC
Impact resistance		500 m/s <sup>2</sup>
Terminal block specifications	Screw tightening torque	0.4 to 0.6 Nm/0.4 to 0.7 Nm
	Wire stripping length (recommended)	7 mm
	Connecting wire size	AWG26 to 14 (0.13 to 2.5 mm <sup>2</sup> )
Input/output connector	CS0, CS1	Conforms to MIL-C-83503
	CN0 to CNF	e-con
Ambient temperature		-25 to 75°C

**e-con connector**  
No need for special tools  
and wire stripping.

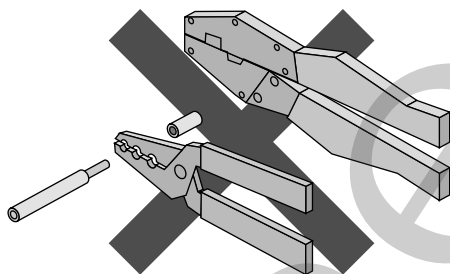

① Insert the electric cables into the cover.

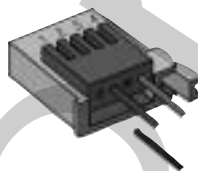

② Press with pliers.  
10 seconds for 4 cables.



## Weights

Model	Weight (g)
PCW-EC16ZBM00	47
PCW-EC16XBR00	
PCW-EC16YBR00	
PCW-EC16ZBM01	87
PCW-EC16XBR01	
PCW-EC16YBR01	
PCW-EC16Z00	38
PCW-EC16Z01	78
PCW-EC08Z00	31
PCW-EC08Z01	58

## Option (e-con Connector)

Model		AWG No.	Cross section of conductor	Finished O.D.	Cover color
1 pc.	10 pcs./pack				
ZS-28-C	ZS-28-C-P	AWG26 to 24	0.14 to 0.2 mm <sup>2</sup>	ø0.8 to ø1.0	Red
ZS-28-C-1	ZS-28-C-1P			ø1.0 to ø1.2	Yellow
ZS-28-C-2	ZS-28-C-2P			ø1.2 to ø1.6	Orange

Note) Applicability varies dependant on conductive construction, conductive material, and/or insulating material even resulting in inapplicable. Consult with P/A and manufacture of connecting equipment.

# Series PCW-EC

# 16 Point Input/Output Branch Unit

## Dimensions

Circuit board type

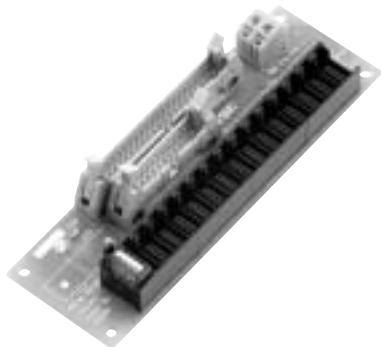

Circuit board type

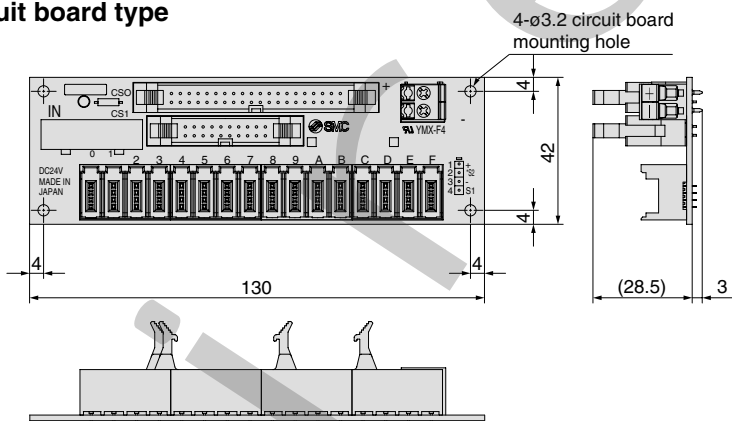

With cover  
(DIN rail mount compatible)

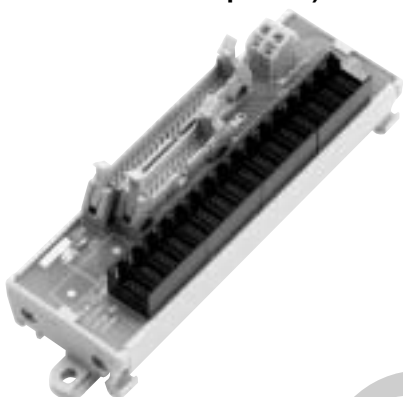

With cover (DIN rail mount compatible)

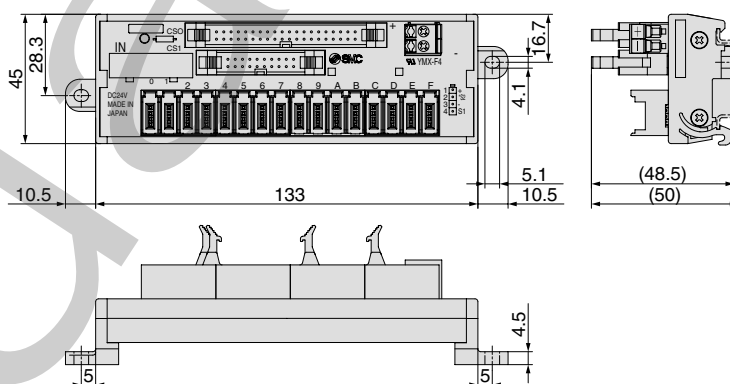

Output unit can be used for mixed connection with PCW series. Refer to the page 58 for details.

## Models

Input	Output	Note
PCW-EC16XBR00	PCW-EC16YBR00	Circuit board type
PCW-EC16XBR01	PCW-EC16YBR01	With cover (DIN rail mount compatible)
PCW-EC16ZBM00		Circuit board type
PCW-EC16ZBM01		With cover (DIN rail mount compatible)

# Series PCW-EC

## Circuit Diagram

PCW-EC16XBR00 [Applicable PLC example: OMRON Corporation C200H-ID218]  
 PCW-EC16XBR01

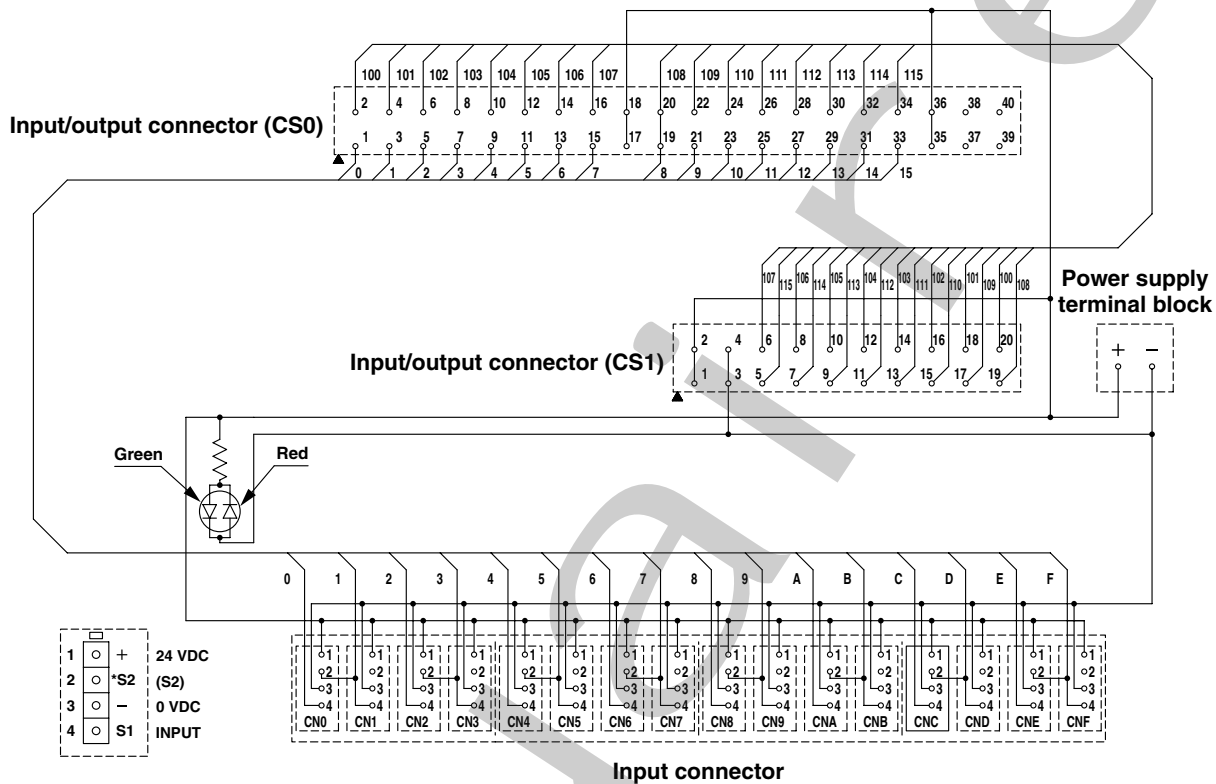

PCW-EC16YBR00 [Applicable PLC example: OMRON Corporation C200H-OD219]  
 PCW-EC16YBR01

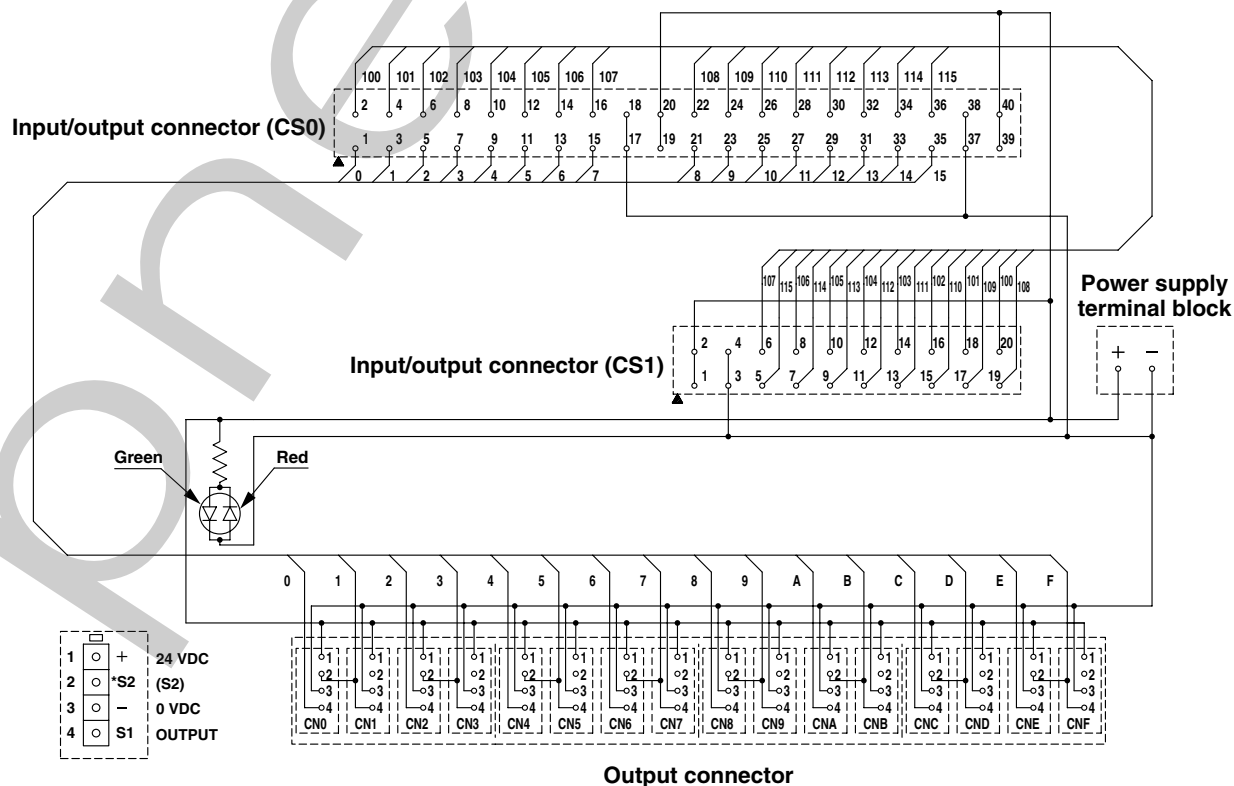



### Circuit Diagram

PCW-EC16ZBM00 [Applicable PLC example: Mitsubishi Electric Corporation A1SX41, A1SY42]  
PCW-EC16ZBM01

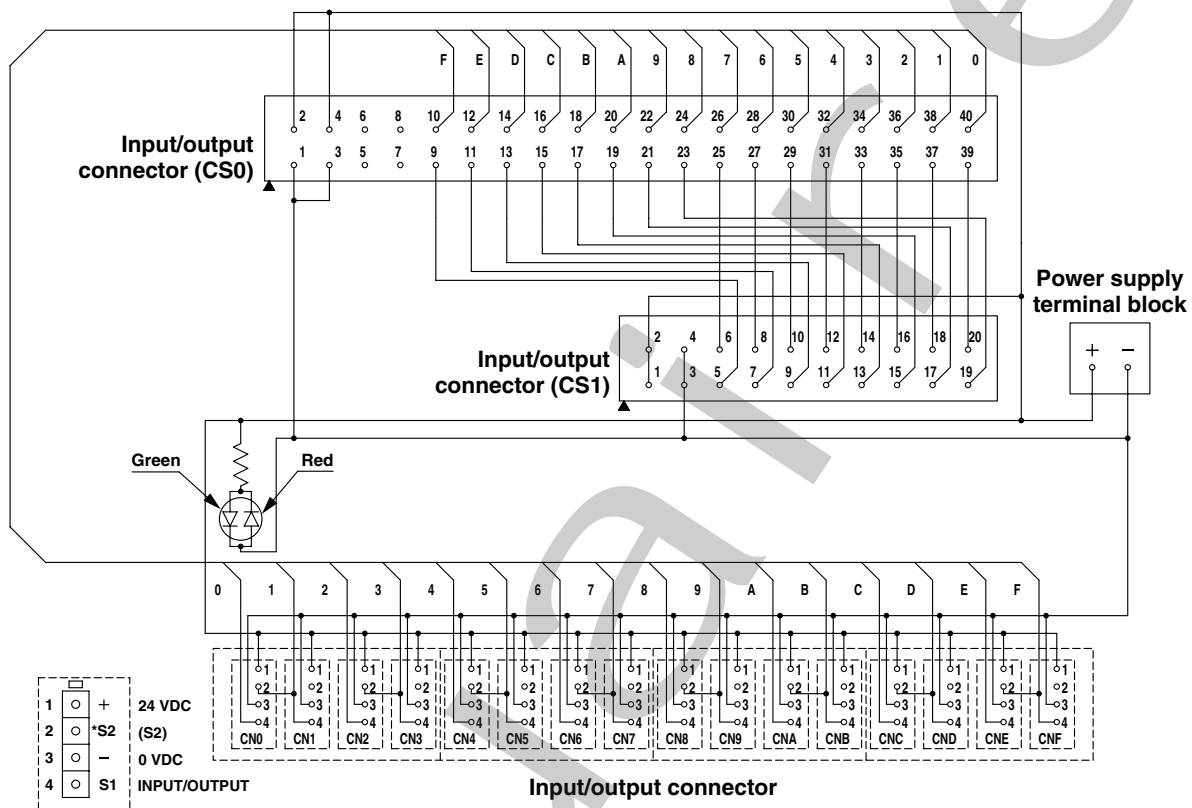

POWER

# Series PCW-EC

# 16 Point Input/Output Unit

Circuit board type

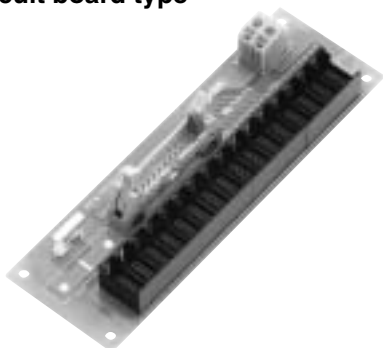

With cover (DIN rail mount compatible)



## Models

PCW-EC16Z00	Circuit board type
PCW-EC16Z01	With cover (DIN rail mount compatible)

## Dimensions

Circuit board type

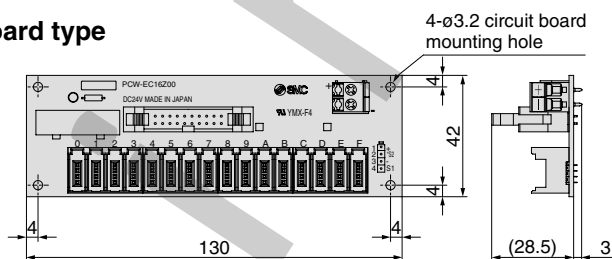

With cover (DIN rail mount compatible)

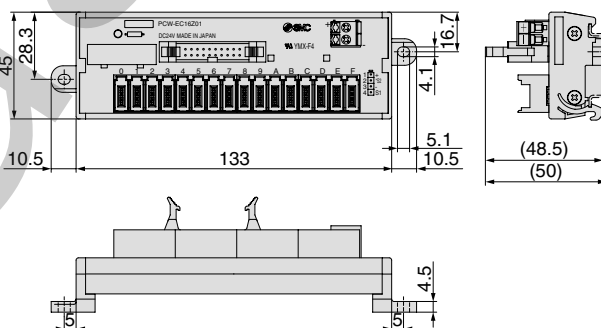

Branch output unit can be used for mixed connection PCW series. Refer to the page 58 for details.

## Circuit Diagram

PCW-EC16Z00  
PCW-EC16Z01

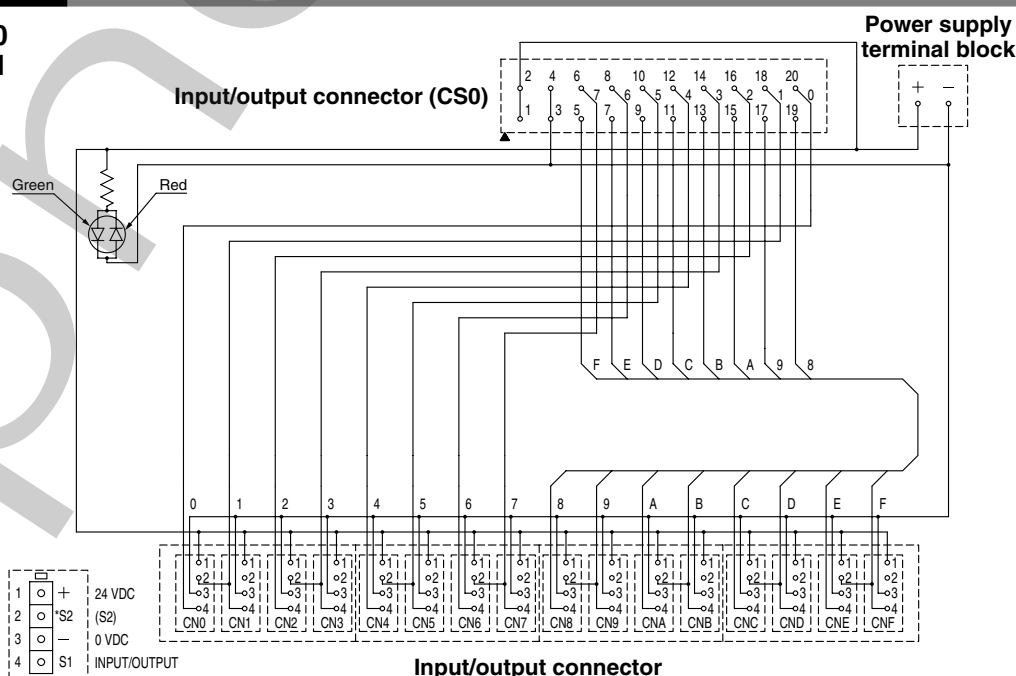

# Series PCW-EC

# 8 Point Input/Output Unit

## Models

Circuit board type

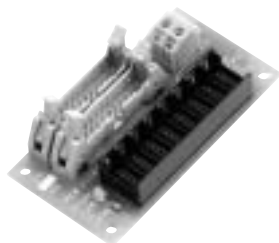

PCW-EC08Z00	Circuit board type
PCW-EC08Z01	With cover (DIN rail mount compatible)

## Dimensions

Circuit board type

4- $\phi$ 3.2 circuit board mounting hole

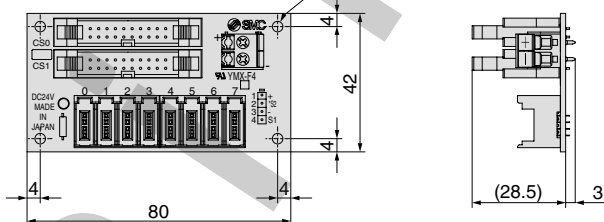

With cover (DIN rail mount compatible)

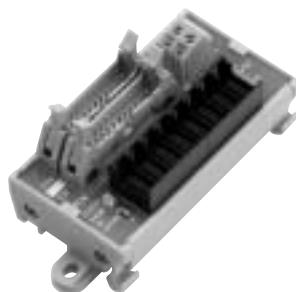

With cover (DIN rail mount compatible)

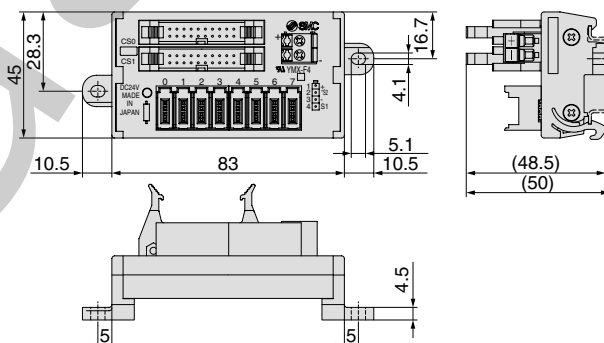

Branch output unit can be used for mixed connection PCW series. Refer to the page 58 for details.

## Circuit Diagram

PCW-EC08Z00  
PCW-EC08Z01

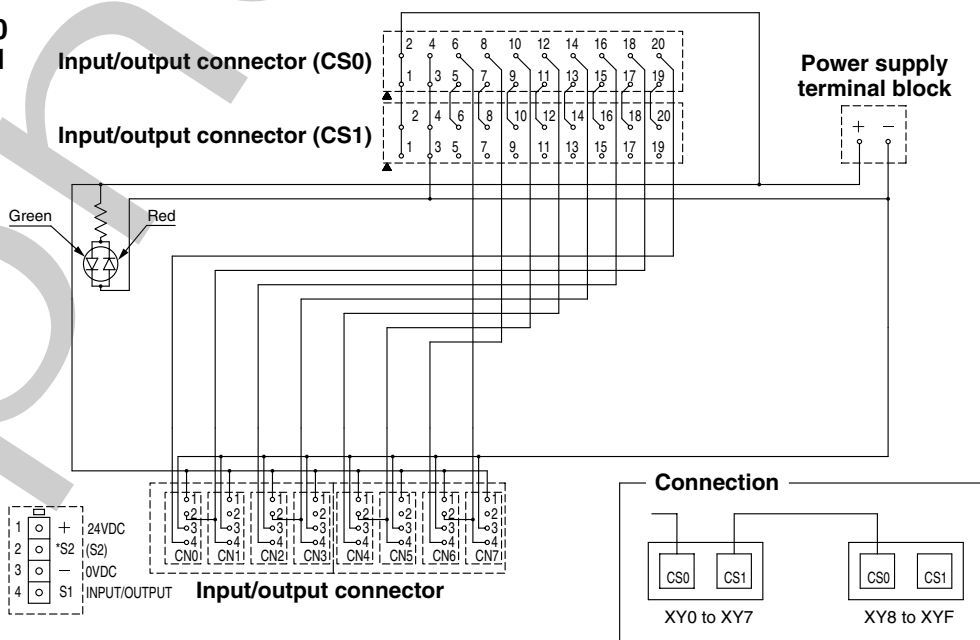

# PC Wiring System

## Series PCW



### Common Specifications



Rated voltage		24 VDC	
Rated current	Power supply line	2 A	
	Communication line	0.3 A	
Insulation resistance		5 MΩ or more at 100 VDC	
Withstand voltage		0.5 kV	
Impact resistance		500 m/s <sup>2</sup>	
Terminal block specifications	Screw tightening torque	Power terminal (Phillips screw driver/Flat head screw driver)	0.4 to 0.6 Nm/0.4 to 0.7 Nm
		I/O terminal (Phillips screw driver/Flat head screw driver)	0.5 to 0.6 Nm/0.5 to 0.7 Nm
	Wire stripping length (recommended)	Power terminal	7 mm
		I/O terminal	
Connecting wire size	Power terminal	AWG26 to 14 (0.13 to 2.5 mm <sup>2</sup> )	
	I/O terminal	AWG26 to 12 (0.13 to 4 mm <sup>2</sup> )	

### Cable Specifications

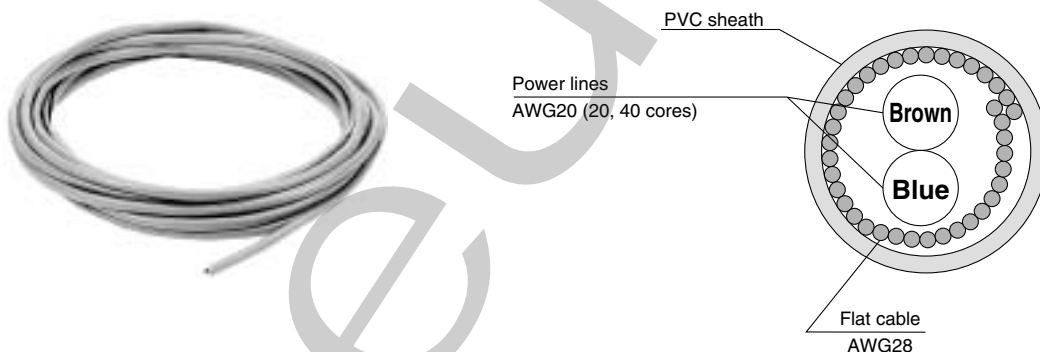

Model	With power lines		Without power lines		
	PCW-9930661H	PCW-9903491H			
Flat cable	20 cores	40 cores	20 cores	34 cores	40 cores
	AWG28 (7 wires/0.127 mm)				
Length	100 m roll		—		
Power lines	AWG20 (21 wires/0.18 mm)		—		
Sheath O.D.	10.3 mm	12.0 mm	8.7 mm	11.8 mm	13.0 mm

Note) The flat ribbon cable without power lines are not available from P/A.  
If required, please source locally from your preferred supplier.

### Clamping tool PCW-994518



# Series PCW

# Branch Unit: PLC Direct Connected Type

### PLC connection



→ PLC

Can be directly mounted on PLC.

### Specifications

Weight	25 g
Ambient temperature	-25 to 55°C

Note) Since some series PCW specifications are included in the common specifications, also refer to the common specifications on page 7.

### Dimensions

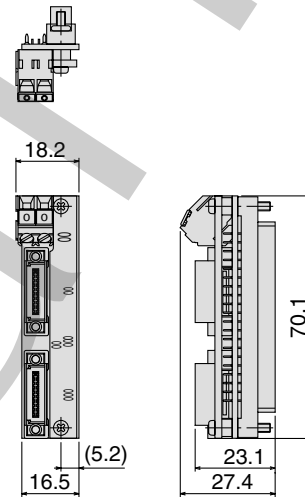
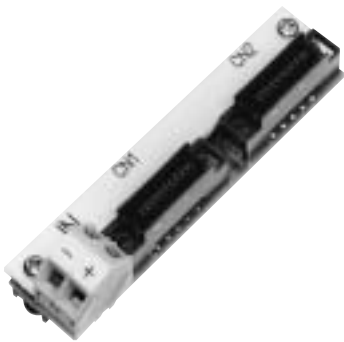

### Models

E-con type 16 point output unit can be used for mixed connection of branch output unit and PCW-EC series.  
Connecting branch input unit to PCW-EC is not possible.  
Refer to the page 58 for details.

Input	Output	Circuit diagram
PCW-993104	PCW-993105	page 9
PCW-993106 <sup>Note 1)</sup>	PCW-993107 <sup>Note 2)</sup>	page 10
PCW-993155 <sup>Note 3)</sup>	PCW-993156 <sup>Note 4)</sup>	page 11

Two pieces are required for 64 points of input/output.

Note 1) Combine one piece each of PCW-993106 and PCW-993108 (the PLC connection side connectors are reversed).

Note 2) Combine one piece each of PCW-993107 and PCW-993109 (the PLC connection side connectors are reversed).

Note 3) Combine one piece each of PCW-993155 and PCW-993174 (the PLC connection side connectors are reversed).

Note 4) Combine one piece each of PCW-993156 and PCW-993175 (the PLC connection side connectors are reversed).

### ⚠ Caution

When removing a cable with connector, a PCW-04T puller is required.

