

Low Profile Single Axis Electric Actuator

Series **LG1H**

High Rigidity Direct Acting Guide

Series	Motor type	Guide type	Mounting orientation	Motor/Screw connection	Model	Lead screw lead mm			Page		
						Ground ball screw	Rolled ball screw	Slide screw			
LG1H	Standard motor	High rigidity direct acting guide	Horizontal	Without coupling	LG1□H20	10	20	10	20	20	148
				With coupling	LG1□H21	10	20	10	20	20	158
	Non-standard motor			With coupling	LG1□H21	10	20	10	20	20	168

- Options _____ Page 178
- Construction _____ 179
- Mounting _____ 181
- Non-standard Motor Mounting _____ 182
- Deflection Data _____ 183

LG1

LG1

LC1

LX

LC6D/LC6C

Switches

Part Number Designations

LG1 □ H 21 G 2 1 P A - 100 - F □ - X10

Frame material

Nll	Aluminium alloy
W	Stainless steel

Guide type

H	High rigidity direct acting guide
---	-----------------------------------

Series

20	Without coupling
21	With coupling

Motor specification

Nll	Standard motor
G	Matsushita Electric Industrial Co., Ltd.
R	Mitsubishi Electric Corporation
Y	Yaskawa Electric Corporation

Motor output

2	100W
---	------

Power supply voltage

1	100/110VAC (50/60Hz) 100/115VAC (50/60Hz)
2	200/220VAC (50/60Hz) 200/230VAC (50/60Hz)
0	Without motor

Stroke

A	10mm
C	20mm

Lead screw lead

A	10mm
C	20mm

Lead screw type

P	Ground ball screw
N	Rolled ball screw
S	Slide screw

Cable entry direction

F	Axial
---	-------

Frame material

Nll	None
W	B contact specification 2 pcs.

Cable length

2	2m
3	3m
4	4m
5	5m

Non-standard motor

X10	Non-standard motor
-----	--------------------

The tables above show the definition for each symbol only and cannot be used for actual model selection.

Standard Motor

Series LG1 H20

Motor Output

100W

High Rigidity
Direct Acting
Guide

Ground Ball Screw

ø15mm/10mm lead

Horizontal Mount

Without Coupling

How to Order

LG1 **H202** **1** **PA** — **Stroke** — **F** **2**

● Power voltage		● Cable length	
1	100/110VAC (50/60Hz)	2	2m
2	200/220VAC (50/60Hz)	3	3m
		4	4m
		5	5m
● Frame material			
Nil	Aluminum alloy		
T	Stainless steel		

Specifications

		Standard stroke	mm	100	200	300	400
Performance	Body weight	Aluminum	kg	5.3	6.1	6.9	7.7
		Stainless steel	kg	8.3	9.6	10.8	12.0
	Operating temperature range	°C	5 to 40 (with no condensation)				
	Work load	kg	30				
	Rated thrust	N	180				
	Maximum speed	mm/s	500				
Main parts	Motor	AC servomotor (100W)					
	Encoder	Incremental system					
	Lead screw	Ground ball screw ø15mm, 10mm lead					
	Guide	High rigidity direct acting guide					
	Motor/Screw connection	Without coupling					
Controller	Model	LC1-1F2HA□-□□ (Refer to page 185 for details.)					

Intermediate strokes

For manufacture of strokes other than the standard strokes on the left, add "-X2" at the end of the part number.
Applicable strokes: 150, 250, 350
Example) **LG1H2021PA-150-F2-X2**

Allowable Moment (N·m)

Allowable static moment

Pitching	71
Rolling	79
Yawing	75

m : Transfer load (kg)
a : Work piece acceleration (mm/s²)
Me : Dynamic moment
L : Overhang to work piece center of gravity (mm)

Allowable dynamic moment

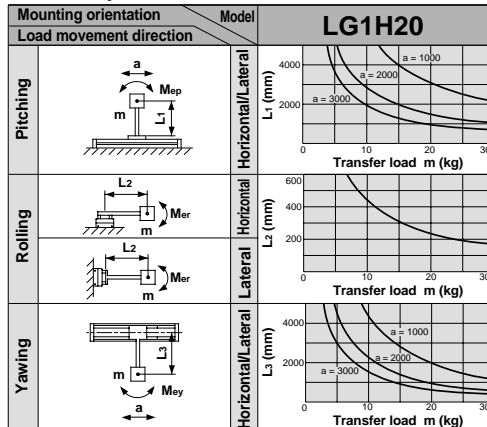

Refer to page 183 for deflection data.

Standard Motor/Horizontal Mount Specification **Series LG1□H20**

Dimensions/LG1□H20□PA

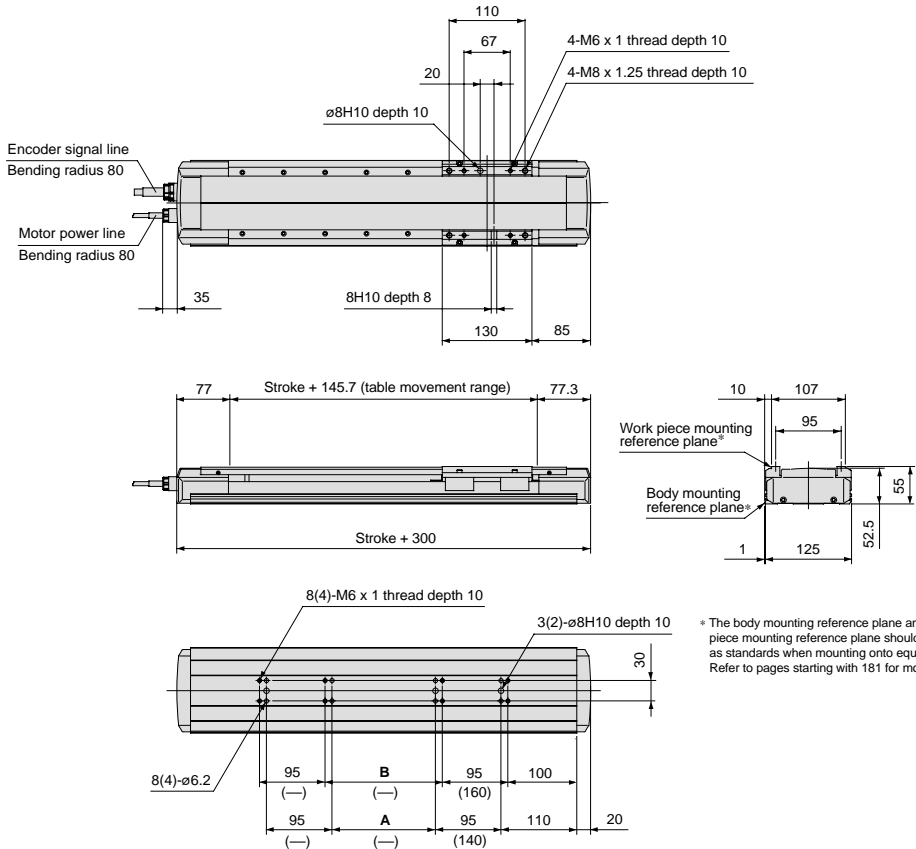

Model	Stroke	A	B
LG1□H20□PA-100-F□*	100	—	—
LG1□H20□PA-200-F□	200	50	70
LG1□H20□PA-300-F□	300	150	170
LG1□H20□PA-400-F□	400	250	270

* Dimensions inside () are for a 100 mm stroke.

Positioning Time Guide

Positioning distance (mm)	Positioning time (sec.)					
	1	10	100	200	400	
Speed (mm/s)	10	0.5	1.4	10.4	20.4	40.4
	100	0.5	0.6	1.5	2.5	4.5
	250	0.5	0.6	0.9	1.3	2.1
	500	0.5	0.6	0.8	1.0	1.4

* Values will vary slightly depending on the operating conditions.

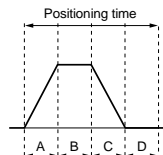

A: Acceleration time
 B: Constant velocity time
 C: Deceleration time
 D: Resting time (0.4sec.)
 Maximum acceleration: 3000mm/s²

LG1

LG1

LG1

LX

LC6D/LC6C

Switches

Standard Motor

Series LG1 H20

Motor Output

100W

High Rigidity
Direct Acting
Guide

Ground Ball Screw

∅15mm/20mm lead

Horizontal Mount

Without Coupling

How to Order

LG1 **H202** **1** **PC** **Stroke** **F** **2**

• **Frame material**

Nil	Aluminum alloy
T	Stainless steel

• **Power supply voltage**

1	100/110VAC (50/60Hz)
2	200/220VAC (50/60Hz)

• **Cable length**

2	2m
3	3m
4	4m
5	5m

Specifications

		Standard stroke	mm	500	600	700	800	900	1000
Performance	Body weight	Aluminum	kg	8.5	9.3	10.1	10.9	11.7	12.5
		Stainless steel	kg	13.3	14.5	15.8	17.1	18.3	19.6
	Operating temperature range	°C	5 to 40 (with no condensation)						
	Work load	kg	30						
	Rated thrust	N	90						
	Maximum speed <small>Note)</small>	mm/s	1000	1000	930	740	600	500	
Main parts	Motor	AC servomotor (100W)							
	Encoder	Incremental system							
	Lead screw	Rolled ball screw ∅15mm, 20mm lead							
	Guide	High rigidity direct acting guide							
	Motor/Screw connection	Without coupling							
Controller	Model	LC1-1F2HC□-□□ (Refer to page 185 for details.)							

Intermediate strokes
For manufacture of strokes other than the standard strokes on the left, add "-X2" at the end of the part number. Applicable strokes: 450, 550, 650, 750, 850, 950
Example) **LG1H2021PC-550-F2-X2**

Note) The speed is limited by the transfer load. Refer to the maximum speeds for each transfer load on the next page.

Allowable Moment (N·m)

Allowable static moment

Pitching	71
Rolling	79
Yawing	75

m : Transfer load (kg)
a : Work piece acceleration (mm/s²)
Me: Dynamic moment
L : Overhang to work piece center of gravity (mm)

Allowable dynamic moment

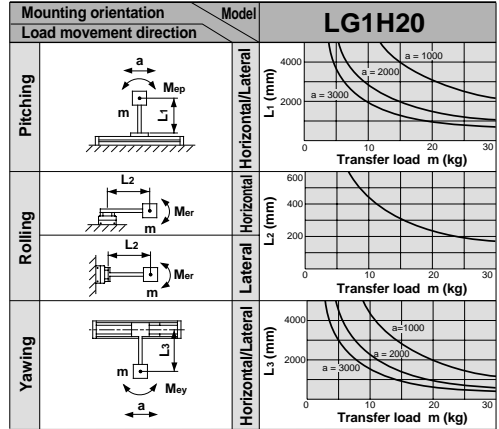

Refer to page 183 for deflection data.

Standard Motor/Horizontal Mount Specification **Series LG1□H20**

Dimensions/LG1□H20□PC

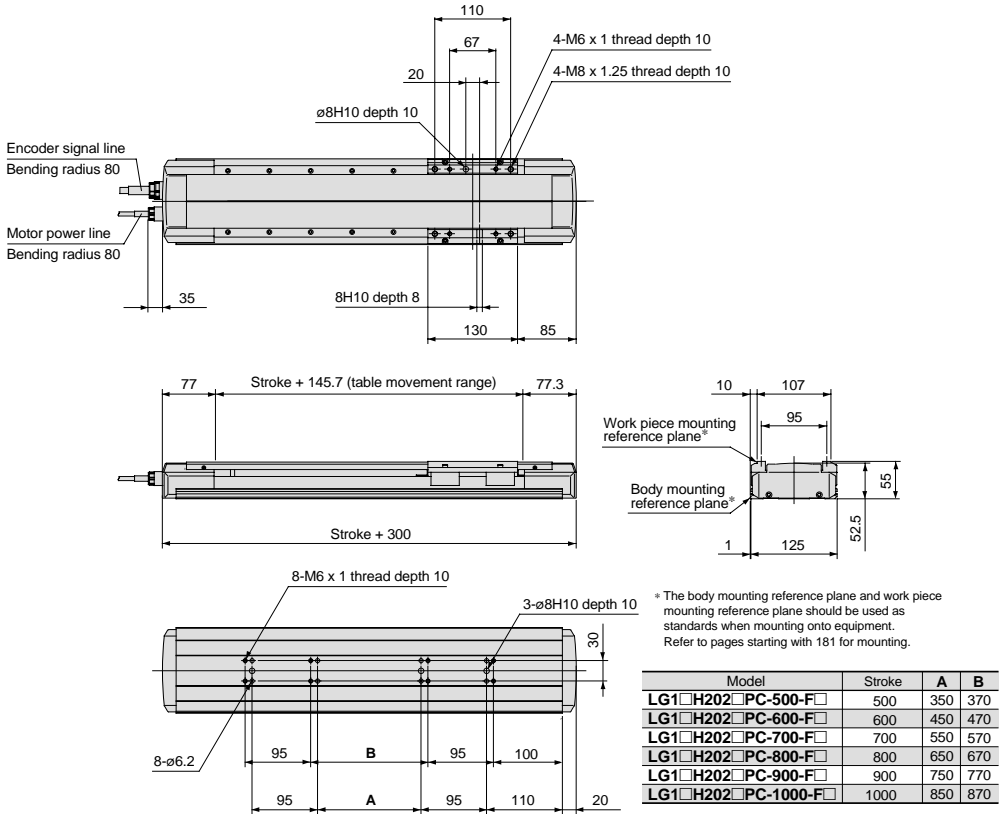

Positioning Time Guide

		Positioning time (sec.)				
Positioning distance (mm)		1	10	100	500	1000
Speed (mm/s)	10	0.5	1.5	10.5	50.5	100.5
	100	0.5	0.6	1.5	5.5	10.5
	500	0.5	0.6	0.9	1.7	2.7
	1000	0.5	0.6	0.9	1.4	1.9

* Values will vary slightly depending on the operating conditions.

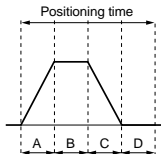

A: Acceleration time
 B: Constant velocity time
 C: Deceleration time
 D: Resting time (0.4sec.)
 Maximum acceleration: 2000mm/s²

Maximum Speeds for Each Transfer Load

Model	Transfer load (kg)				Note
	15	20	25	30	
LG1□H20□PC-500-F□	1000	700	500	500	Power supply: 100/110(V)AC ±10% Compatible controller: LC1-1□2HC1-□□
LG1□H20□PC-600-F□	1000	700	500	500	
LG1□H20□PC-700-F□	930	600	500	500	
LG1□H20□PC-800-F□	740	600	500	500	
LG1□H20□PC-900-F□	600	500	500	500	Power supply: 200/220(V)AC ±10% Compatible controller: LC1-1□2HC2-□□
LG1□H20□PC-1000-F□	500	500	500	500	

* Consult SMC if outside of the above conditions.

Standard Motor

Series **LG1** **H20**

Motor Output

100WHigh Rigidity
Direct Acting
Guide

Rolled Ball Screw

ø15mm/10mm lead

Horizontal Mount

Without Coupling

How to Order

LG1 **□** H202 **1** **NA** — Stroke — F **2**

• Frame material

Nil	Aluminum alloy
T	Stainless steel

• Power supply voltage

1	100/110VAC (50/60Hz)
2	200/220VAC (50/60Hz)

• Cable length

2	2m
3	3m
4	4m
5	5m

Specifications

Standard stroke		mm	100	200	300	400	
Performance	Body weight	Aluminum	kg	5.3	6.1	6.9	7.7
		Stainless steel	kg	8.3	9.6	10.8	12.0
	Operating temperature range	°C	5 to 40 (with no condensation)				
	Work load	kg	30				
	Rated thrust	N	180				
	Maximum speed	mm/s	500				
Main parts	Positioning repeatability	mm	±0.05				
	Motor	AC servomotor (100W)					
	Encoder	Incremental system					
	Lead screw	Rolled ball screw ø15mm, 10mm lead					
	Guide	High rigidity direct acting guide					
Controller	Motor/Screw connection	Without coupling					
	Model	LC1-1F2HA□-□□ (Refer to page 185 for details.)					

Intermediate strokes

For manufacture of strokes other than the standard strokes on the left, add "-X2" at the end of the part number.
Applicable strokes: 150, 250, 350

Example) LG1H2021NA-150-F2-X2

Allowable Moment (N·m)

Allowable static moment

Pitching	71
Rolling	79
Yawing	75

m : Transfer load (kg)

a : Work piece acceleration (mm/s²)

Me : Dynamic moment

L : Overhang to work piece center of gravity (mm)

Allowable dynamic moment

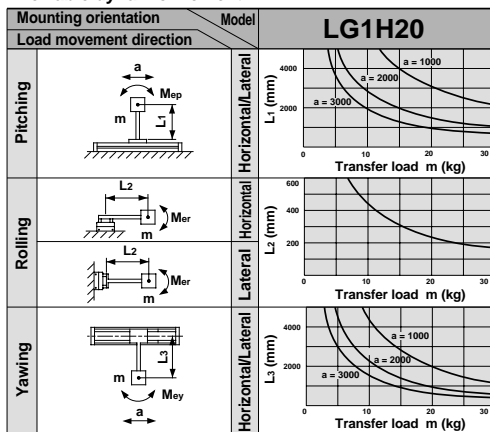

Refer to page 183 for deflection data.

Dimensions/LG1□H20□PA

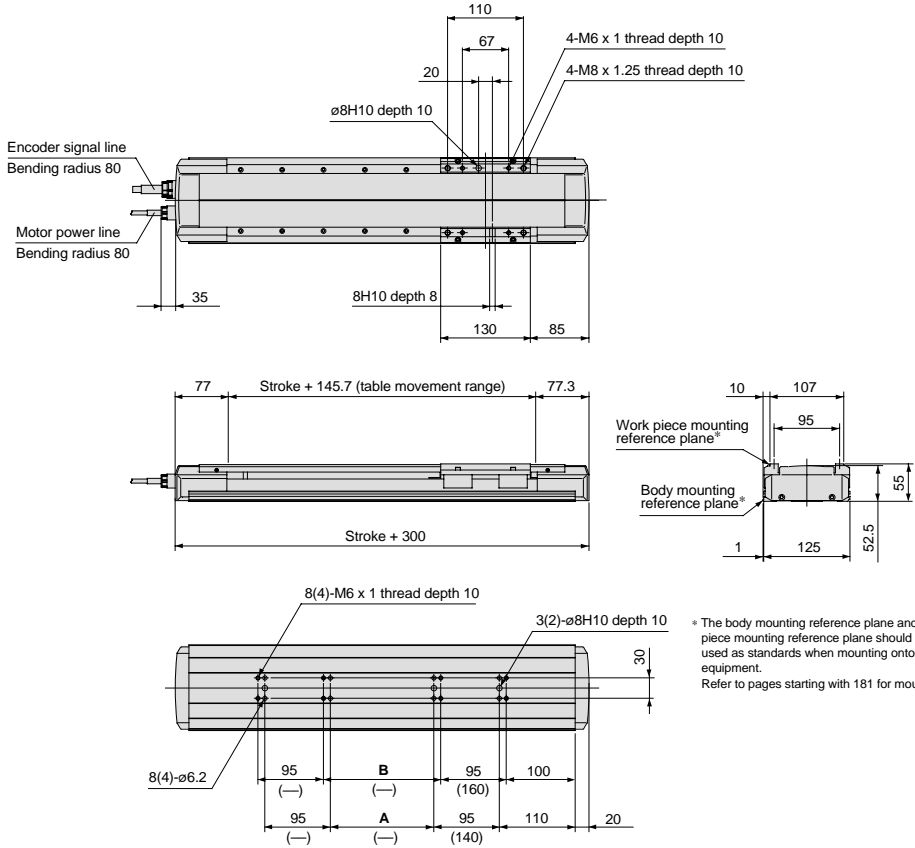

Model	Stroke	A	B
LG1□H20□PA-100-F□*	100	—	—
LG1□H20□PA-200-F□	200	50	70
LG1□H20□PA-300-F□	300	150	170
LG1□H20□PA-400-F□	400	250	270

* Dimensions inside () are for a 100 mm stroke.

Positioning Time Guide

Positioning distance (mm)	Positioning time (sec.)					
	1	10	100	200	400	
Speed (mm/s)	10	0.5	1.4	10.4	20.4	40.4
	100	0.5	0.6	1.5	2.5	4.5
	250	0.5	0.6	0.9	1.3	2.1
	500	0.5	0.6	0.8	1.0	1.4

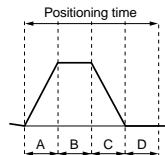

* Values will vary slightly depending on the operating conditions.

LG1

LG1

LG1

LX

LC6D/LC6C

Switches

Standard Motor

Series LG1 H20

Motor Output

100W

High Rigidity
Direct Acting
Guide

Rolled Ball Screw

∅15mm/20mm lead

Horizontal Mount

Without Coupling

How to Order

LG1 **H202** **1** **NC** — **Stroke** — **F** **2**

• **Frame material**

Nil	Aluminum alloy
T	Stainless steel

• **Power supply voltage**

1	100/110VAC (50/60Hz)
2	200/220VAC (50/60Hz)

• **Cable length**

2	2m
3	3m
4	4m
5	5m

Specifications

Standard stroke		mm	500	600	700	800	900	1000	
Performance	Body weight	Aluminum	kg	8.5	9.3	10.1	10.9	11.7	12.5
		Stainless steel	kg	13.3	14.5	15.8	17.1	18.3	19.6
	Operating temperature range	°C	5 to 40 (with no condensation)						
	Work load	kg	30						
	Rated thrust	N	90						
	Maximum speed <small>Note)</small>	mm/s	1000	1000	930	740	600	500	
Main parts	Positioning repeatability	mm	±0.05						
	Motor	AC servomotor (100W)							
	Encoder	Incremental system							
	Lead screw	Rolled ball screw ∅15mm, 20mm lead							
	Guide	High rigidity direct acting guide							
Motor/Screw connection	Without coupling								
Controller	Model	LC1-1F2HC□-□□ (Refer to page 185 for details.)							

Intermediate strokes

For manufacture of strokes other than the standard strokes on the left, add "-X2" at the end of the part number.
Applicable strokes: 450, 550, 650, 750, 850, 950
Example) **LG1H2021NC-550-F2-X2**

Note) The speed is limited by the transfer load. Refer to the maximum speeds for each transfer load on the next page.

Allowable Moment (N·m)

Allowable static moment

Pitching	71
Rolling	79
Yawing	75

- m : Transfer load (kg)
- a : Work piece acceleration (mm/s²)
- Me: Dynamic moment
- L : Overhang to work piece center of gravity (mm)

Allowable dynamic moment

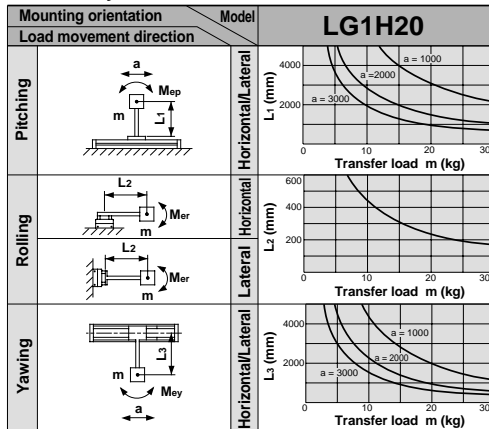

Refer to page 183 for deflection data.

Standard Motor/Horizontal Mount Specification **Series LG1□H20**

Dimensions/LG1□H20□NC

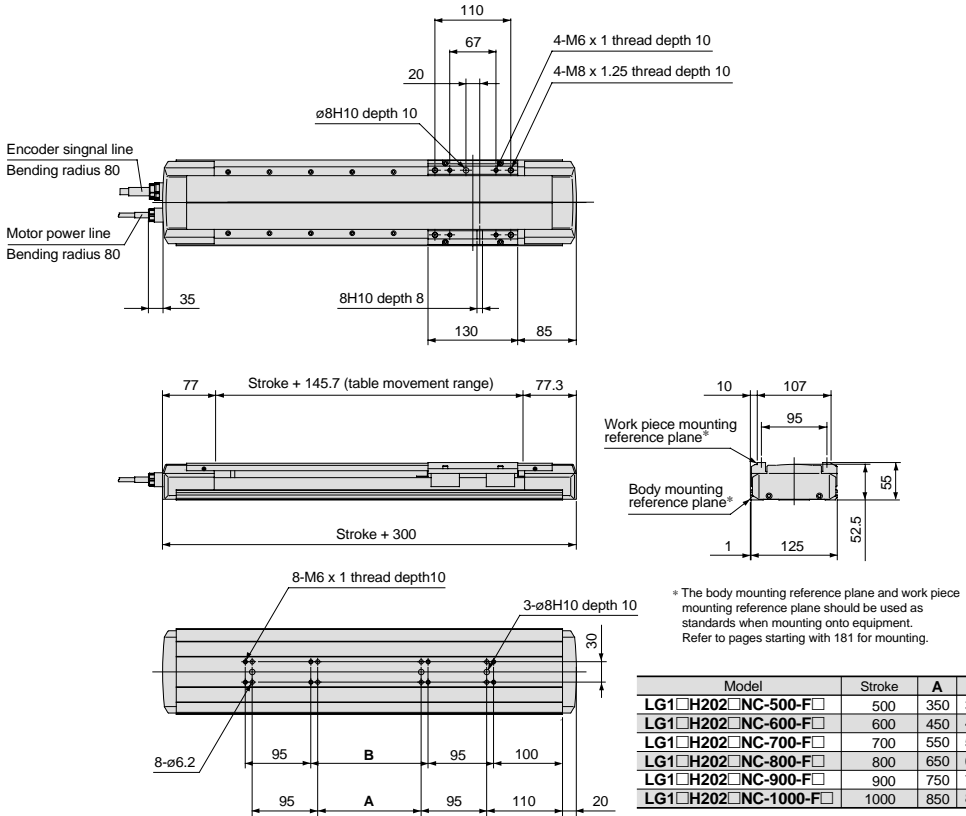

Positioning Time Guide

		Positioning time (sec.)				
Positioning distance (mm)		1	10	100	500	1000
Speed (mm/s)	10	0.5	1.5	10.5	50.5	100.5
	100	0.5	0.6	1.5	5.5	10.5
	500	0.5	0.6	0.9	1.7	2.7
	1000	0.5	0.6	0.9	1.4	1.9

* Values will vary slightly depending on the operating conditions.

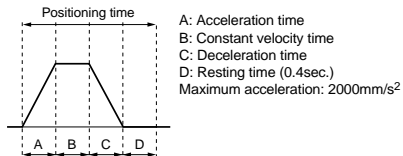

Maximum Speeds for Each Transfer Load

Model	Transfer load (kg)				Note
	15	20	25	30	
LG1□H20□NC-500-F□	1000	700	500	500	Power supply: 100/110(V)AC ±10% Compatible controller: LC1-1□2HC1-□□
LG1□H20□NC-600-F□	1000	700	500	500	
LG1□H20□NC-700-F□	930	600	500	500	
LG1□H20□NC-800-F□	740	600	500	500	
LG1□H20□NC-900-F□	600	500	500	500	
LG1□H20□NC-1000-F□	500	500	500	500	Power supply: 200/220(V)AC ±10% Compatible controller: LC1-1□2HC2-□□

* Consult SMC if outside of the above conditions.

Standard Motor

Series LG1 H20

Horizontal Mount

Without Coupling

Motor Output

100W

High Rigidity
Direct Acting
Guide

Slide Screw

ø20mm/20mm lead

How to Order

LG1 H202 1 SC — Stroke — F 2

Frame material

Nil	Aluminum alloy
T	Stainless steel

Power supply voltage

1	100/110VAC (50/60Hz)
2	200/220VAC (50/60Hz)

Cable length

2	2m
3	3m
4	4m
5	5m

Specifications

Standard stroke		mm	100	200	300	400	500	600	700	800	900	1000	1200	
Performance	Body weight	Aluminum	kg	5.8	6.7	7.6	8.5	9.4	10.2	11.1	12.0	12.9	13.8	15.9
		Stainless steel	kg	9.1	10.5	11.9	13.2	14.6	16.0	17.4	18.8	20.1	21.6	24.9
	Operating temperature range	°C	5 to 40 (with no condensation)											
	Work load	kg	15											
	Rated thrust	N	50											
	Maximum speed	mm/s	500											
Main parts	Positioning repeatability	mm	±0.1											
	Motor	AC servomotor (100W)												
	Encoder	Incremental system												
	Lead screw	Slide screw ø20mm, 20mm lead												
	Guide	High rigidity direct acting guide												
Controller	Motor/Screw connection	Without coupling												
	Model	LC1-1F2MC (Refer to page 185 for details.)												

Intermediate strokes

For manufacture of strokes other than the standard strokes above, add "-X2" at the end of the part number.

Applicable strokes: 150, 250, 350, 450, 550, 650, 750, 850, 950, 1050

Example) LG1H2021SC-150-F2-X2

Allowable Moment (N·m)

Allowable static moment

Pitching	71
Rolling	79
Yawing	75

m : Transfer load (kg)

a : Work piece acceleration (mm/s²)

Me : Dynamic moment

L : Overhang to work piece center of gravity (mm)

Allowable dynamic moment

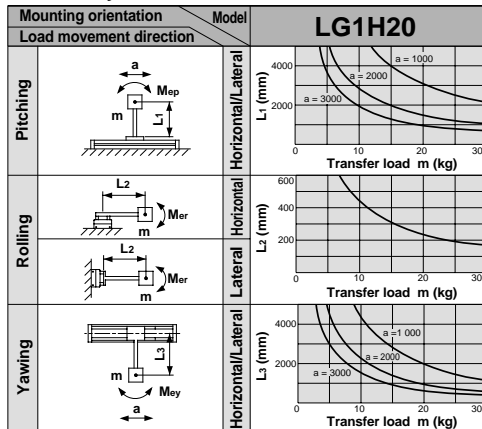

Refer to page 183 for deflection data.

Standard Motor/Horizontal Mount Specification **Series LG1□H20**

Dimensions/LG1□H202□SC

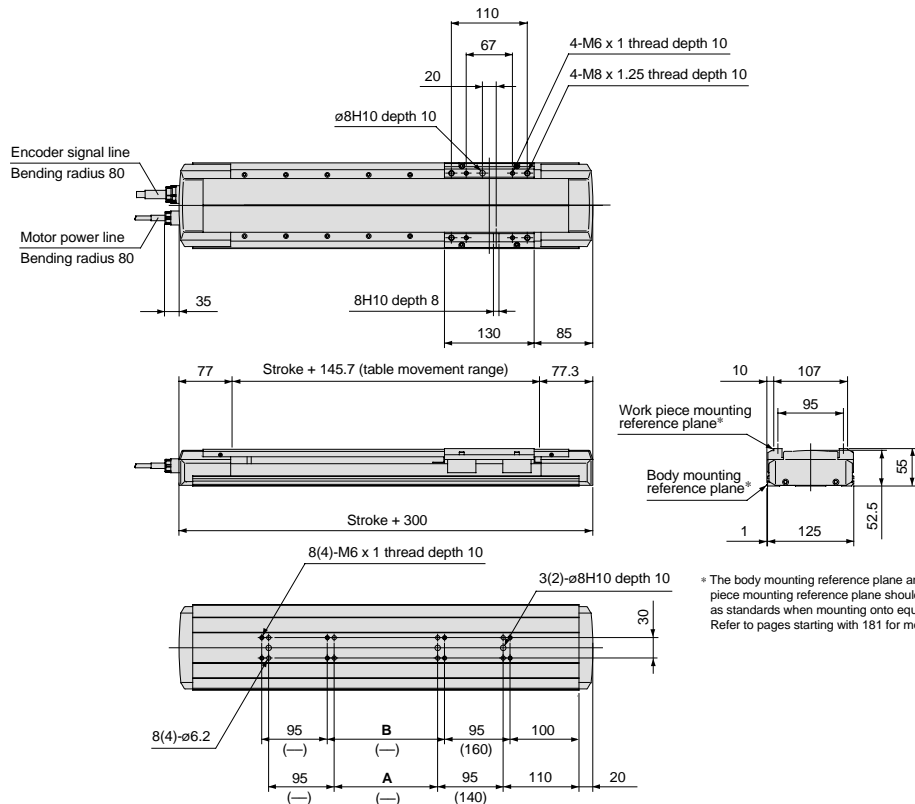

Model	Stroke	A	B
LG1□H202□SC-100-F□*	100	—	—
LG1□H202□SC-200-F□	200	50	70
LG1□H202□SC-300-F□	300	150	170
LG1□H202□SC-400-F□	400	250	270
LG1□H202□SC-500-F□	500	350	370
LG1□H202□SC-600-F□	600	450	470
LG1□H202□SC-700-F□	700	550	570
LG1□H202□SC-800-F□	800	650	670
LG1□H202□SC-900-F□	900	750	770
LG1□H202□SC-1000-F□	1000	850	870
LG1□H202□SC-1200-F□	1200	1050	1070

* Dimensions inside () are for a 100 mm stroke.

Positioning Time Guide

		Positioning time (sec.)				
Positioning distance (mm)		1	10	100	600	1200
Speed (mm/s)	10	0.5	1.5	10.5	60.5	120.5
	100	0.5	0.6	1.5	6.5	12.5
	250	0.5	0.6	1.0	3.0	5.4
	500	0.5	0.6	0.9	1.9	3.1

* Values will vary slightly depending on the operating conditions.

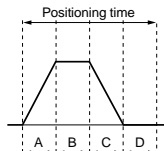

A: Acceleration time
B: Constant velocity time
C: Deceleration time
D: Resting time (0.4sec.)
Maximum acceleration: 2000mm/s²

LG1

LG1

LG1

LX

LC6D/LC6C

Switches

Standard Motor

Series LG1 H21

Horizontal Mount

With Coupling

Motor Output

100W

High Rigidity
Direct Acting
Guide

Ground Ball Screw

∅15mm/10mm lead

How to Order

LG1 **H212** **1** **PA** — **Stroke** — **F** **2**

• **Power supply voltage**

1	100/110VAC (50/60Hz)
2	200/220VAC (50/60Hz)

• **Cable length**

2	2m
3	3m
4	4m
5	5m

• **Frame material**

NII	Aluminum alloy
T	Stainless steel

Specifications

		Standard stroke	mm	100	200	300	400
Performance	Body weight	Aluminum	kg	5.3	6.1	6.9	7.7
		Stainless steel	kg	8.3	9.6	10.8	12.0
	Operating temperature range	°C	5 to 40 (with no condensation)				
	Work load	kg	30				
	Rated thrust	N	180				
	Maximum speed	mm/s	500				
Main parts	Motor	AC servomotor (100W)					
	Encoder	Incremental system					
	Lead screw	Ground ball screw ∅15mm, 10mm lead					
	Guide	High rigidity direct acting guide					
	Motor/Screw connection	With coupling					
Controller	Model	LC1-1D2HA□□□ (Refer to page 185 for details.)					

Intermediate strokes

For manufacture of strokes other than the standard strokes on the left, add "-X2" at the end of the part number.
Applicable strokes: 150, 250, 350
Example) **LG1H2121PA-150-F2-X2**

Allowable Moment (N·m)

Allowable static moment

Pitching	142
Rolling	79
Yawing	150

m : Transfer load (kg)
a : Work piece acceleration (mm/s²)
Me: Dynamic moment
L : Overhang to work piece center of gravity (mm)

Allowable dynamic moment

Mounting orientation		Model
Pitching	Horizontal	
	Lateral	
	Horizontal	
Rolling	Horizontal	
	Lateral	
Yawing	Horizontal	
	Lateral	

Refer to page 183 for deflection data.

Standard Motor/Horizontal Mount Specification **Series LG1□H21**

Dimensions/LG1□H212□PA

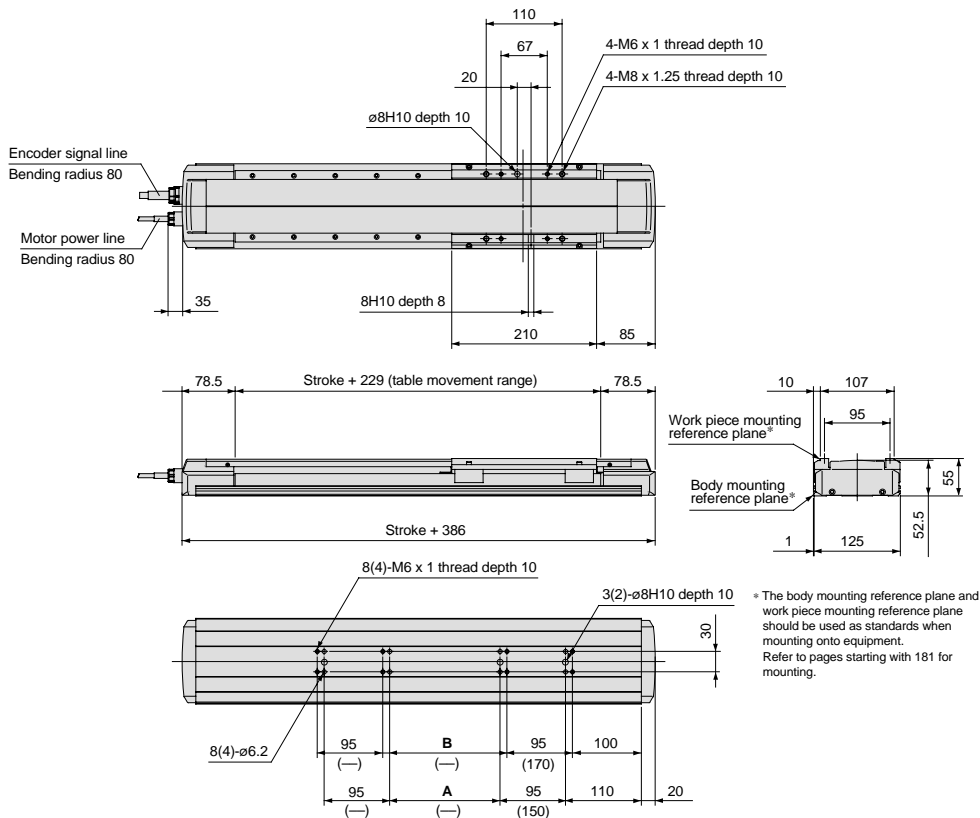

Model	Stroke	A	B
LG1□H212□PA-100-F□*	100	—	—
LG1□H212□PA-200-F□	200	60	80
LG1□H212□PA-300-F□	300	160	180
LG1□H212□PA-400-F□	400	260	280

* Dimensions inside () are for a 100 mm stroke.

Positioning Time Guide

Positioning distance (mm)	Positioning time (sec.)					
	1	10	100	200	400	
Speed (mm/s)	10	0.5	1.4	10.4	20.4	40.4
	100	0.5	0.6	1.5	2.5	4.5
	250	0.5	0.6	0.9	1.3	2.1
	500	0.5	0.6	0.8	1.0	1.4

* Values will vary slightly depending on the operating conditions.

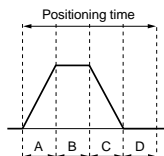

A: Acceleration time
B: Constant velocity time
C: Deceleration time
D: Resting time (0.4sec.)
Maximum acceleration: 3000mm/s²

LJ1
 LG1
 LC1
 LX
 LC6D/LC6C
 Switches

Standard Motor

Series LG1 H21

Motor Output

100W

High Rigidity
Direct Acting
Guide

Ground Ball Screw

ø15mm/20mm lead

Horizontal Mount

With Coupling

How to Order

LG1 **H212** 1 **PC** **Stroke** **F** 2

• **Frame material**

Nil	Aluminum alloy
T	Stainless steel

• **Power supply voltage**

1	100/110VAC (50/60Hz)
2	200/220VAC (50/60Hz)

• **Cable length**

2	2m
3	3m
4	4m
5	5m

Specifications

		Standard stroke	mm	500	600	700	800	900	1000
Performance	Body weight	Aluminum	kg	8.5	9.3	10.1	10.9	11.7	12.5
		Stainless steel	kg	13.3	14.5	15.8	17.1	18.3	19.6
	Operating temperature range	°C	5 to 40 (with no condensation)						
	Work load	kg	30						
	Rated thrust	N	90						
	Maximum speed <small>(Note)</small>	mm/s	1000	1000	930	740	600	500	
	Positioning repeatability	mm	±0.02						
Main parts	Motor	AC servomotor (100W)							
	Encoder	Incremental system							
	Lead screw	Ground ball screw ø15mm, 20mm lead							
	Guide	High rigidity direct acting guide							
	Motor/Screw connection	With coupling							
Controller	Model	LC1-1D2HC-□-□ (Refer to page 185 for details.)							

Intermediate strokes

For manufacture of strokes other than the standard strokes on the left, add "-X2" at the end of the part number.
Applicable strokes: 450, 550, 650, 750, 850, 950
Example) **LG1H2121PC-550-F2-X2**

(Note) The speed is limited by the transfer load. Refer to the maximum speeds for each transfer load on the next page.

Allowable Moment (N·m)

Allowable static moment

Pitching	142
Rolling	79
Yawing	150

m : Transfer load (kg)
a : Work piece acceleration (mm/s²)
Me : Dynamic moment
L : Overhang to work piece center of gravity (mm)

Allowable dynamic moment

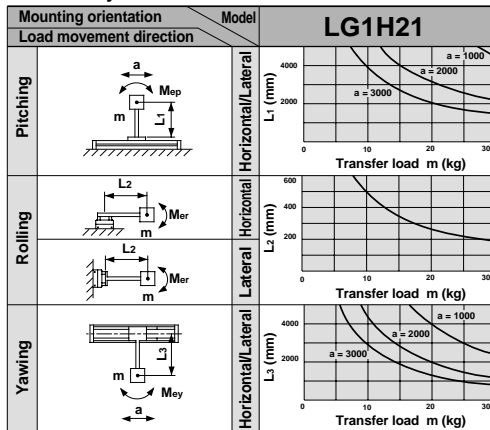

Refer to page 183 for deflection data.

Standard Motor/Horizontal Mount Specification **Series LG1□H21**

Dimensions/LG1□H212□PC

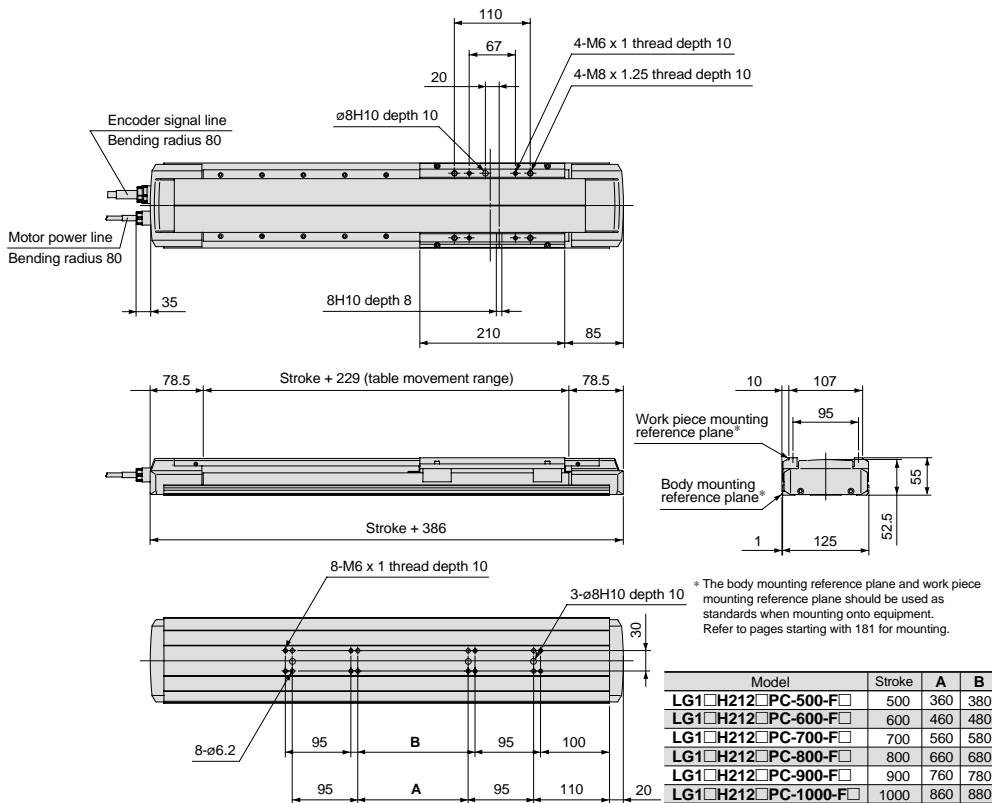

Positioning Time Guide

Positioning distance (mm)		Positioning time (sec.)				
		1	10	100	500	1000
Speed (mm/s)	10	0.5	1.5	10.5	50.5	100.5
	100	0.5	0.6	1.5	5.5	10.5
	500	0.5	0.6	0.9	1.7	2.7
	1000	0.5	0.6	0.9	1.4	1.9

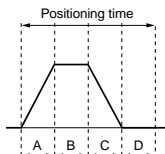

A: Acceleration time
 B: Constant velocity time
 C: Deceleration time
 D: Resting time (0.4sec.)
 Maximum acceleration: 2000mm/s²

* Values will vary slightly depending on the operating conditions.

Maximum Speeds for Each Transfer Load

Model	Transfer load (kg)				Note
	15	20	25	30	
LG1□H202□PC-500-F□	1000	700	500	500	Power supply: 100/110(V)AC ±10% Compatible controller: LC1-1□2HC1-□□
LG1□H202□PC-600-F□	1000	700	500	500	
LG1□H202□PC-700-F□	930	600	500	500	
LG1□H202□PC-800-F□	740	600	500	500	
LG1□H202□PC-900-F□	600	500	500	500	Power supply: 200/220(V)AC ±10% Compatible controller: LC1-1□2HC2-□□
LG1□H202□PC-1000-F□	500	500	500	500	

* Consult SMC if outside of the above conditions.

LJ1
 LG1
 LC1
 LX
 LC6D/LC6C
 Switches

Standard Motor
Horizontal Mount

Series LG1 H21
With Coupling

Motor Output
100W

High Rigidity
Direct Acting
Guide

Rolled Ball Screw
∅15mm/10mm lead

How to Order

LG1 H212 1 **NA** — Stroke — F 2

• **Frame material**

Nil	Aluminum alloy
T	Stainless steel

• **Power supply voltage**

1	100/110VAC (50/60Hz)
2	200/220VAC (50/60Hz)

• **Cable length**

2	2m
3	3m
4	4m
5	5m

Specifications

Standard stroke		mm	100	200	300	400		
Performance	Body weight	Aluminum	kg	5.3	6.1	6.9	7.7	
		Stainless steel	kg	8.3	9.6	10.8	12.0	
	Operating temperature range	°C					5 to 40 (with no condensation)	
	Work load	kg		30				
	Rated thrust	N		180				
	Maximum speed	mm/s		500				
Positioning repeatability	mm		±0.05					
Main parts	Motor	AC servomotor (100W)						
	Encoder	Incremental system						
	Lead screw	Rolled ball screw ∅15mm, 10mm lead						
	Guide	High rigidity direct acting guide						
	Motor/Screw connection	With coupling						
Controller	Model	LC1-1D2HA□□□ (Refer to page 185 for details.)						

Intermediate strokes

For manufacture of strokes other than the standard strokes on the left, add "-X2" at the end of the part number.
Applicable strokes: 150, 250, 350
Example) **LG1H2121NA-150-F2-X2**

Allowable Moment (N·m)

Allowable static moment

Pitching	142
Rolling	79
Yawing	150

m : Transfer load (kg)
a : Work piece acceleration (mm/s²)
Me : Dynamic moment
L : Overhang to work piece center of gravity (mm)

Allowable dynamic moment

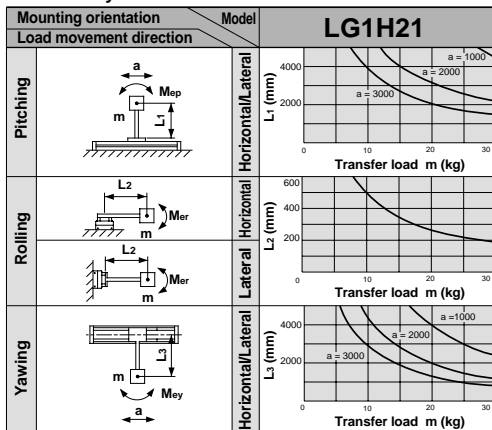

Refer to page 183 for deflection data.

Standard Motor/Horizontal Mount Specification **Series LG1□H21**

Dimensions/LG1□H212□NA

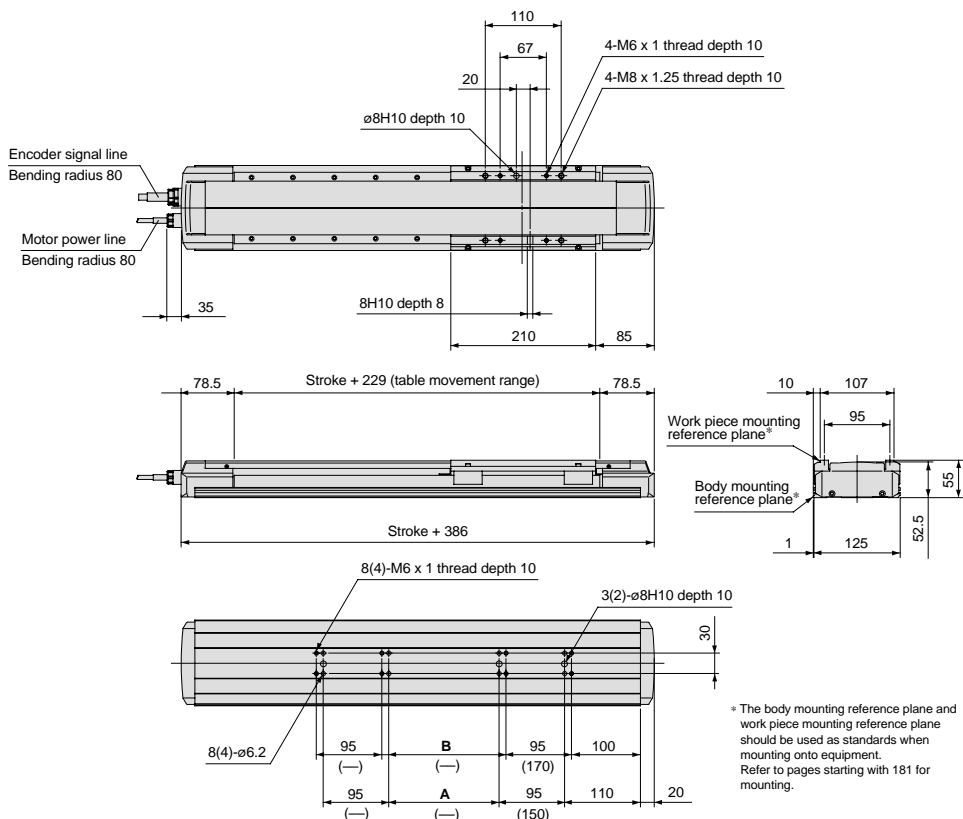

Model	Stroke	A	B
LG1□H212□NA-100-F□*	100	—	—
LG1□H212□NA-200-F□	200	60	80
LG1□H212□NA-300-F□	300	160	180
LG1□H212□NA-400-F□	400	260	280

* Dimensions inside () are for a 100 mm stroke.

Positioning Time Guide

Positioning distance (mm)	Positioning time (sec.)					
	1	10	100	200	400	
Speed (mm/s)	10	0.5	1.4	10.4	20.4	40.4
	100	0.5	0.6	1.5	2.5	4.5
	250	0.5	0.6	0.9	1.3	2.1
	500	0.5	0.6	0.8	1.0	1.4

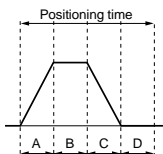

A: Acceleration time
B: Constant velocity time
C: Deceleration time
D: Resting time (0.4sec.)
Maximum acceleration: 3000mm/s²

* Values will vary slightly depending on the operating conditions.

Standard Motor

Series LG1 H21

Motor Output

100W

High Rigidity
Direct Acting
Guide

Rolled Ball Screw

∅15mm/20mm lead

Horizontal Mount

With Coupling

How to Order

LG1 **H212** 1 **NC** **Stroke** **F** 2

• **Frame material**

NII	Aluminum alloy
T	Stainless steel

• **Power supply voltage**

1	100/110VAC (50/60Hz)
2	200/220VAC (50/60Hz)

• **Cable length**

2	2m
3	3m
4	4m
5	5m

Specifications

		Standard stroke	mm	500	600	700	800	900	1000
Performance	Body weight	Aluminum	kg	8.5	9.3	10.1	10.9	11.7	12.5
		Stainless steel	kg	13.3	14.5	15.8	17.1	18.3	19.6
	Operating temperature range	°C	5 to 40 (with no condensation)						
	Work load	kg	30						
	Rated thrust	N	90						
	Maximum speed <small>(Note)</small>	mm/s	1000	1000	930	740	600	500	
Positioning repeatability	mm	±0.05							
Main parts	Motor	AC servomotor (100W)							
	Encoder	Incremental system							
	Lead screw	Rolled ball screw ∅15mm, 20mm lead							
	Guide	High rigidity direct acting guide							
	Motor/Screw connection	With coupling							
Controller	Model	LC1-1D2HC (Refer to page 185 for details.)							

Intermediate strokes

For manufacture of strokes other than the standard strokes on the left, add "-X2" at the end of the part number.

Applicable strokes: 450, 550, 650, 750, 850, 950

Example **LG1H2121NC-550-F2-X2**

Note) The speed is limited by the transfer load. Refer to the maximum speeds for each transfer load on the next page.

Allowable Moment (N·m)

Allowable static moment

Pitching	142
Rolling	79
Yawing	150

- m : Transfer load (kg)
- a : Work piece acceleration (mm/s²)
- Me: Dynamic moment
- L : Overhang to work piece center of gravity (mm)

Allowable dynamic moment

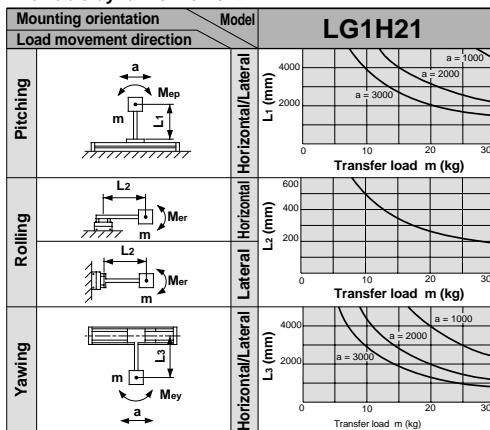

Refer to page 183 for deflection data.

Standard Motor/Horizontal Mount Specification **Series LG1□H21**

Dimensions/LG1□H212□NC

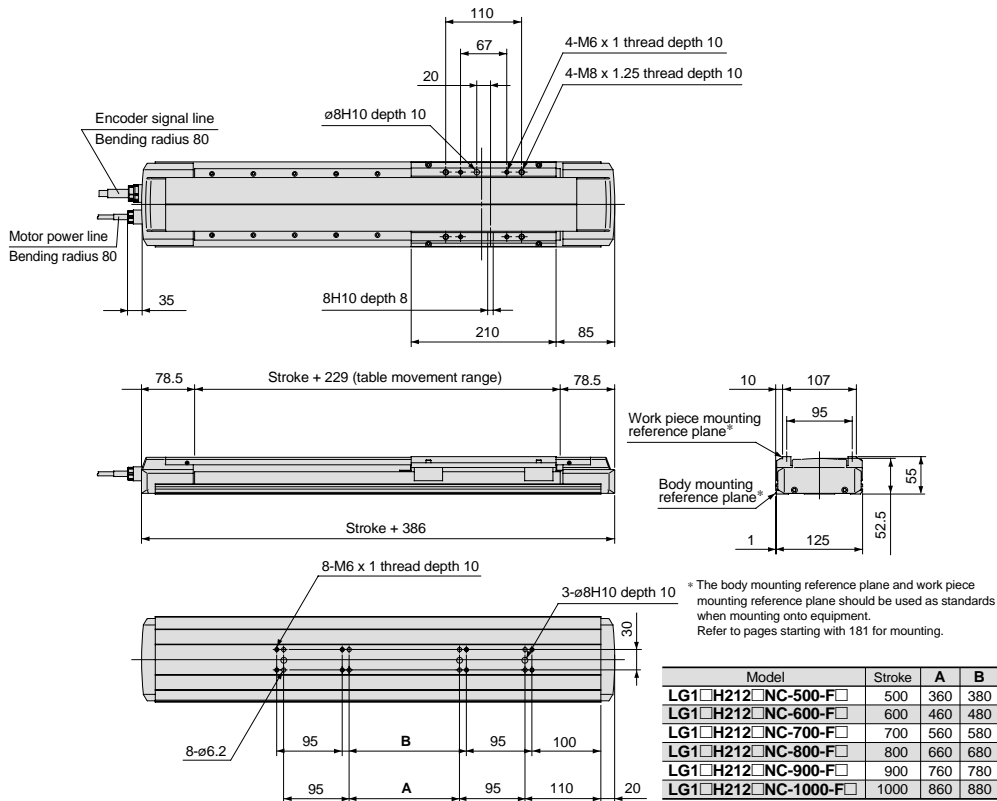

Positioning Time Guide

Positioning distance (mm)	Positioning time (sec.)					
	1	10	100	500	1000	
Speed (mm/s)	10	0.5	1.5	10.5	50.5	100.5
	100	0.5	0.6	1.5	5.5	10.5
	500	0.5	0.6	0.9	1.7	2.7
	1000	0.5	0.6	0.9	1.4	1.9

* Values will vary slightly depending on the operating conditions.

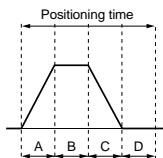

A: Acceleration time
 B: Constant velocity time
 C: Deceleration time
 D: Resting time (0.4sec.)
 Maximum acceleration: 2000mm/s²

Maximum Speeds for Each Transfer Load

Model	Transfer load (kg)				Note
	15	20	25	30	
LG1□H202□NC-500-F□	1000	700	500	500	Power supply: 100/110(V)AC ±10% Compatible controller: LC1-1□2HC1-□□
LG1□H202□NC-600-F□	1000	700	500	500	
LG1□H202□NC-700-F□	930	600	500	500	
LG1□H202□NC-800-F□	740	600	500	500	
LG1□H202□NC-900-F□	600	500	500	500	Power supply: 200/220(V)AC ±10% Compatible controller: LC1-1□2HC2-□□
LG1□H202□NC-1000-F□	500	500	500	500	

* Consult SMC if outside of the above conditions.

Standard Motor**Series LG1 H21**

Motor Output

100WHigh Rigidity
Direct Acting
Guide

Slide Screw

ø20mm/20mm lead

Horizontal Mount**With Coupling****How to Order**LG1 H212 1 **SC** — Stroke — F 2• **Frame material**

Nil	Aluminum alloy
T	Stainless steel

• **Power supply voltage**

1	100/110VAC (50/60Hz)
2	200/220VAC (50/60Hz)

• **Cable length**

2	2m
3	3m
4	4m
5	5m

Specifications

		Standard stroke	mm	100	200	300	400	500	600	700	800	900	1000	1200
Performance	Body weight	Aluminum	kg	5.8	6.7	7.6	8.5	9.4	10.2	11.1	12.0	12.9	13.8	15.9
		Stainless steel	kg	9.1	10.5	11.9	13.2	14.6	16.0	17.4	18.8	20.1	21.6	24.9
	Operating temperature range	°C	5 to 40 (with no condensation)											
	Work load	kg	15											
	Rated thrust	N	50											
	Maximum speed	mm	500											
Main parts	Positioning repeatability	mm	±0.1											
	Motor	AC servomotor (100W)												
	Encoder	Incremental system												
	Lead screw	Slide screw ø20mm, 20mm lead												
	Guide	High rigidity direct acting guide												
Motor/Screw connection	With coupling													
Controller	Model	LC1-1D2MC□-□□ (Refer to page 185 for details.)												

Intermediate strokes

For manufacture of strokes other than the standard strokes above, add "-X2" at the end of the part number.

Applicable strokes: 150, 250, 350, 450, 550, 650, 750, 850, 950, 1050

Example) LG1H212SC-150-F2-X2

Allowable Moment (N·m)**Allowable static moment**

Pitching	142
Rolling	79
Yawing	150

m : Transfer load (kg)

a : Work piece acceleration (mm/s²)

Me : Dynamic moment

L : Overhang to work piece center of gravity (mm)

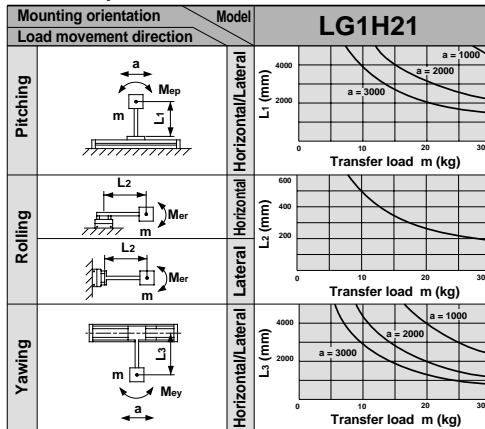
Allowable dynamic moment

Refer to page 183 for deflection data.

Standard Motor/Horizontal Mount Specification **Series LG1□H21**

Dimensions/LG1□H212□SC

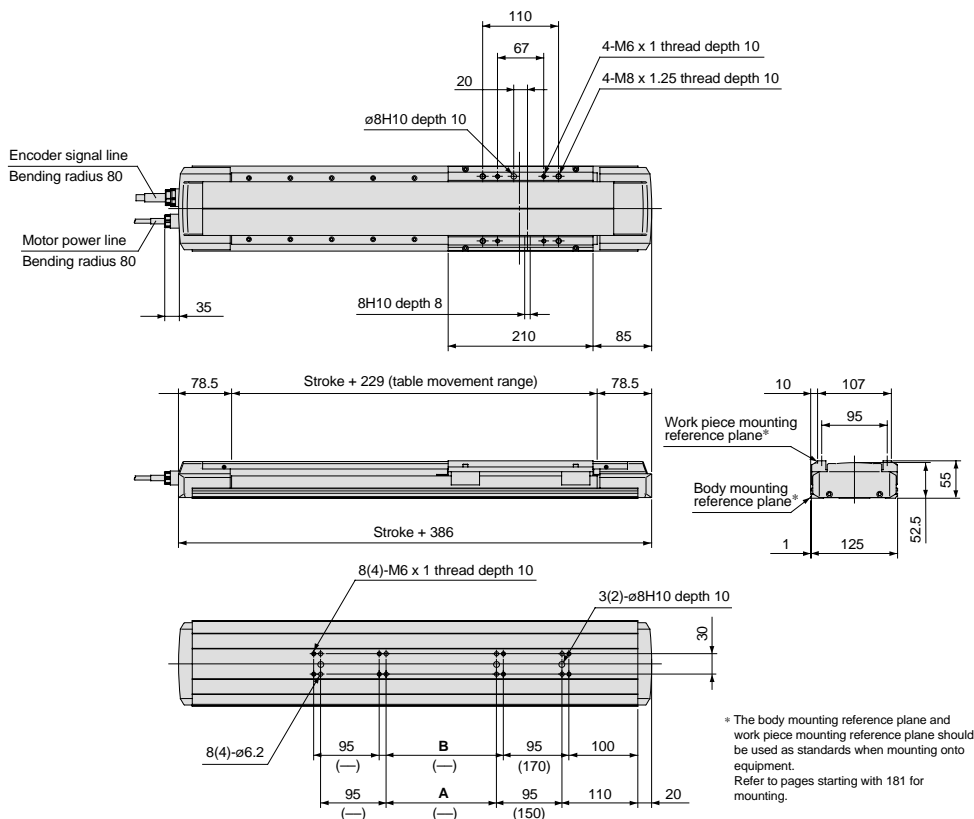

Model	Stroke	A	B
LG1□H212□SC-100-F□*	100	—	—
LG1□H212□SC-200-F□	200	60	80
LG1□H212□SC-300-F□	300	160	180
LG1□H212□SC-400-F□	400	260	280
LG1□H212□SC-500-F□	500	360	380
LG1□H212□SC-600-F□	600	460	480
LG1□H212□SC-700-F□	700	560	580
LG1□H212□SC-800-F□	800	660	680
LG1□H212□SC-900-F□	900	760	780
LG1□H212□SC-1000-F□	1000	860	880
LG1□H212□SC-1200-F□	1200	1060	1080

* Dimensions inside () are for a 100 mm stroke.

Positioning Time Guide

		Positioning time (sec.)					
Positioning distance (mm)		1	10	100	600	1200	
Speed (mm/s)	10	0.5	1.5	10.5	60.5	120.5	
	100	0.5	0.6	1.5	6.5	12.5	
	250	0.5	0.6	1.0	3.0	5.4	
	500	0.5	0.6	0.9	1.9	3.1	

* Values will vary slightly depending on the operating conditions.

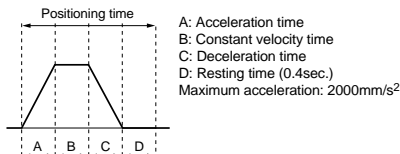

Non-standard Motor
Horizontal Mount

Series LG1 H21
With Coupling

Motor Output
100W

High Rigidity
Direct Acting
Guide

Ground ball Screw
ø15mm/10mm lead

How to Order

LG1 **H21** **G** **2** **1** **PA** — **Stroke** — **F** **W** — **X10**

Frame material

Nil	Aluminum alloy
T	Stainless steel

Motor specification

G	Matsushita Electric Industrial Co., Ltd.
R	Mitsubishi Electric Corporation
Y	Yaskawa Electric Corporation

Power supply voltage

1	100/115VAC (50/60Hz)
2	200/230VAC (50/60Hz)
0	Without motor

Switch

Nil	None
W	N.C. (B contact) 2 pcs.

Specifications

Standard stroke		mm	100	200	300	400
Performance	Body weight	Aluminum (without motor)	5.2	6.0	6.8	7.6
		Stainless steel (without motor)	8.4	9.7	10.9	12.2
	Operating temperature range	°C	5 to 40 (with no condensation)			
	Work load	kg	30			
	Maximum speed	mm/s	500			
	Positioning repeatability	mm	±0.02			
Main parts	Motor	AC servomotor (100W)				
	Encoder	Incremental system				
	Lead screw	Ground ball screw ø15mm, 10mm lead				
	Guide	High rigidity direct acting guide				
	Motor/Screw connection	With coupling				
Switch	Model	Photo micro sensor EE-SX674 (Refer to page 319 for details.)				
	Specifications	5 to 24VDC Load current (1C): 100mA, Internal voltage drop: 0.8V or less Load current (1C): 40mA, Internal voltage drop: 0.4V or less				

Intermediate strokes

Strokes other than the standard strokes on the left are available by special order. Consult SMC.

Allowable Moment (N·m)

Allowable static moment

Pitching	142
Rolling	79
Yawing	150

m : Transfer load (kg)
a : Work piece acceleration (mm/s²)
Me: Dynamic moment
L : Overhang to work piece center of gravity (mm)

Allowable dynamic moment

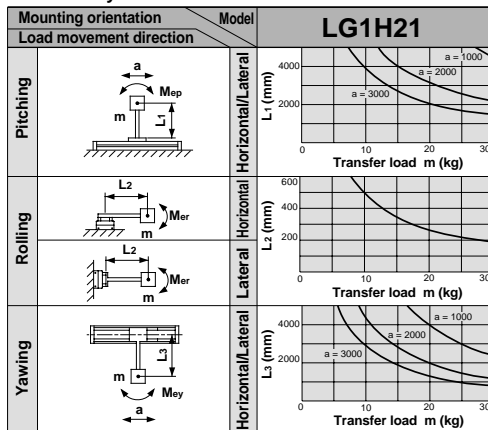

Refer to page 183 for deflection data.

Non-standard Motor/Horizontal Mount Specification **Series LG1□H21**

Dimensions/LG1□H21□2□PA (X10)

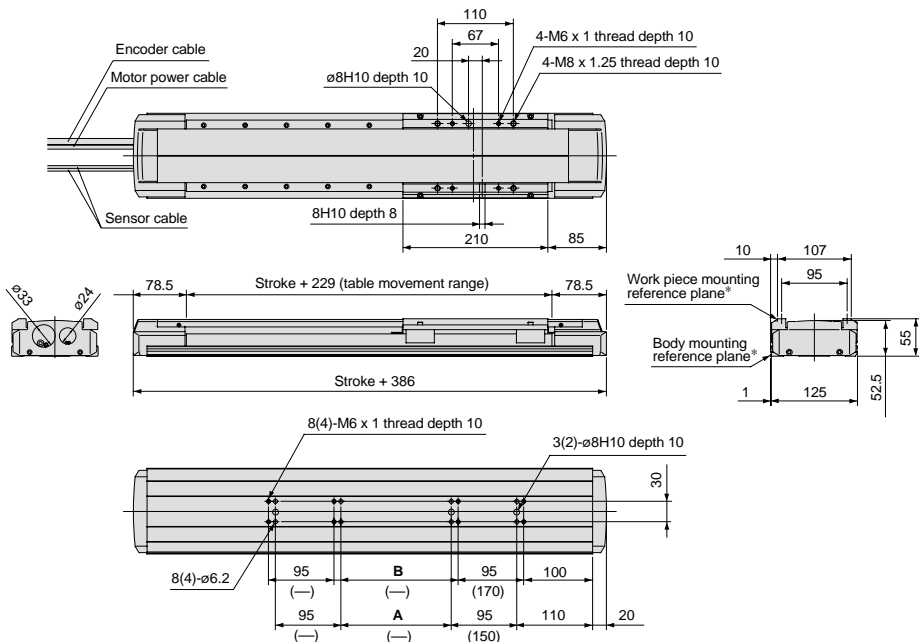

Model	Stroke	A	B
LG1□H21□2□PA-100-F□-X10	100	—	—
LG1□H21□2□PA-200-F□-X10	200	60	80
LG1□H21□2□PA-300-F□-X10	300	160	180
LG1□H21□2□PA-400-F□-X10	400	260	280

* Dimensions inside () are for a 100 mm stroke.

* The body mounting reference plane and work piece mounting reference plane should be used as standards when mounting onto equipment.
Refer to pages starting with 181 for mounting.

Positioning Time Guide

Positioning distance (mm)	Positioning time (sec.)					
	1	10	100	200	400	
Speed (mm/s)	10	0.5	1.4	10.4	20.4	40.4
	100	0.5	0.6	1.5	2.5	4.5
	250	0.5	0.6	0.9	1.3	2.1
	500	0.5	0.6	0.8	1.0	1.4

* Values will vary slightly depending on the operating conditions.

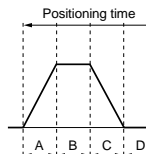

A: Acceleration time
B: Constant velocity time
C: Deceleration time
D: Resting time (0.4sec.)*
Maximum acceleration: 3000mm/s²

* The value is a guide when SMC's series LCI controller is used and may vary depending on the driver capacity.

Non-standard Motors: The following motors will be mounted when a motor mounted type is specified.

	Motor output (W)	Power supply voltage (VAC)	Motor model	Compatible driver model
Matsushita Electric Industrial Co., Ltd.	100	100/115	MSM011P1A	MSD011P1E
		200/230	MSM012P1A	MSD013P1E
Mitsubishi Electric Corporation	100	100/115	HC-PQ13	MR-C10A1
		200/230		MR-C10A
Yaskawa Electric Corporation	100	100/115	SGME-01BF12	SGDE-01BP
		200/230	SGME-01AF12	SGDE-01AP

* For motor mounting dimensions, refer to the dimensions on page 182 as a reference for mounting and design.

* Refer to pages starting with 205 for driver dimensions, etc. Furthermore, for detailed specifications, etc., contact each motor manufacturer.

* For a non-standard motor specification, when the motor is mounted before shipping, the driver is included but the cable that connects the motor and driver is optional. Refer to page 178 for part numbers.

Non-standard Motor

Series LG1 H21

Horizontal Mount

With Coupling

Motor Output

100W

High Rigidity
Direct Acting
Guide

Ground Ball Screw

ø15mm/20mm lead

How to Order

LG1 H21 G 2 1 PC Stroke F W X10

Frame material

Nil	Aluminum alloy
T	Stainless steel

Motor specification

G	Matsushita Electric Industrial Co., Ltd.
R	Mitsubishi Electric Corporation
Y	Yaskawa Electric Corporation

Power supply voltage

1	100/115VAC (50/60Hz)
2	200/230VAC (50/60Hz)
0	Without motor

Switch

Nil	None
W	N.C. (B contact) 2 pcs.

Specifications

Standard stroke		mm	500	600	700	800	900	1000	
Performance	Body weight	Aluminum (without motor)	kg	8.4	9.2	10.0	10.8	11.6	12.4
		Stainless steel (without motor)	kg	13.4	14.7	15.9	17.2	18.4	19.7
	Operating temperature range	°C	5 to 40 (with no condensation)						
	Work load	kg	30						
	Maximum speed ^{Note}	mm/s	1000	1000	930	740	600	500	
	Positioning repeatability	mm	±0.02						
Main parts	Motor	AC servomotor (100W)							
	Encoder	Incremental system							
	Lead screw	Ground ball screw ø15mm, 20mm lead							
	Guide	High rigidity direct acting guide							
	Motor/Screw connection	With coupling							
Switch	Model	Photo micro sensor EE-SX674 (Refer to page 319 for details.)							
	Specifications	5 to 24VDC Load current (1C): 100mA, Internal voltage drop: 0.8V or less Load current (1C): 40mA, Internal voltage drop: 0.4V or less							

Intermediate strokes

Strokes other than the standard strokes on the left are available by special order. Consult SMC.

Note) When the work load exceeds 15kg, the speed may be limited. Contact SMC in this case.

Allowable Moment (N·m)

Allowable static moment

Pitching	142
Rolling	79
Yawing	150

m : Transfer load (kg)

a : Work piece acceleration (mm/s²)

Me: Dynamic moment

L : Overhang to work piece center of gravity (mm)

Allowable dynamic moment

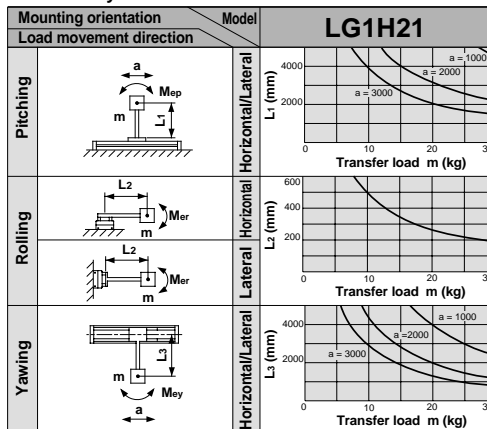

Refer to page 183 for deflection data.

Non-standard Motor/Horizontal Mount Specification **Series LG1□H21**

Dimensions/LG1□H21□2□PC (X10)

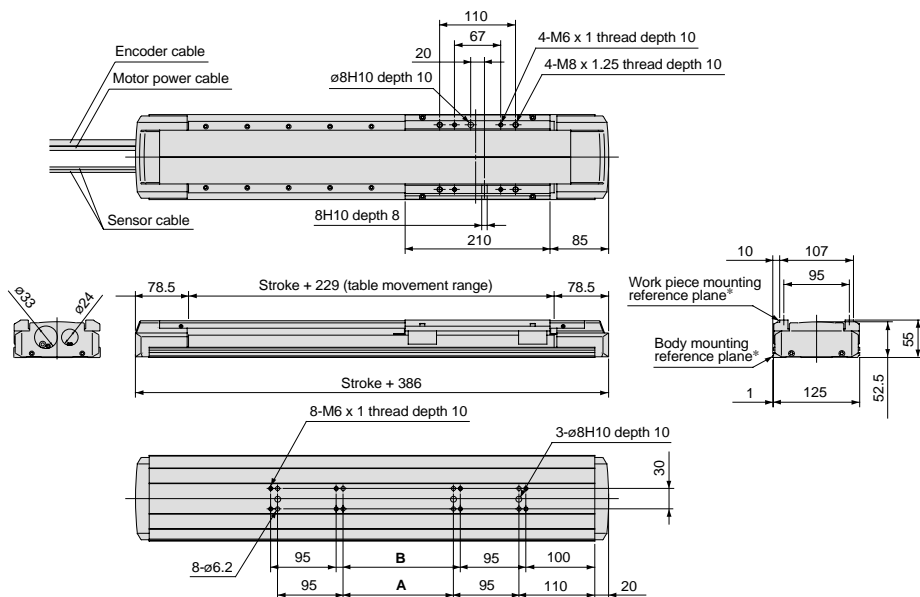

Model	Stroke	A	B
LG1□H21□2□PC-500-F□-X10	500	360	380
LG1□H21□2□PC-600-F□-X10	600	460	480
LG1□H21□2□PC-700-F□-X10	700	560	580
LG1□H21□2□PC-800-F□-X10	800	660	680
LG1□H21□2□PC-900-F□-X10	900	760	780
LG1□H21□2□PC-1000-F□-X10	1000	860	880

* The body mounting reference plane and work piece mounting reference plane should be used as standards when mounting onto equipment.
Refer to pages starting with 181 for mounting.

Positioning Time Guide

Positioning distance (mm)	Positioning time (sec.)					
	1	10	100	500	1000	
Speed (mm/s)	10	0.5	1.5	10.5	50.5	100.5
	100	0.5	0.6	1.5	5.5	10.5
	500	0.5	0.6	0.9	1.7	2.7
	1000	0.5	0.6	0.9	1.4	1.9

* Values will vary slightly depending on the operating conditions.

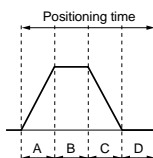

A: Acceleration time
B: Constant velocity time
C: Deceleration time
D: Resting time (0.4sec.)*
Maximum acceleration: 2000mm/s²

* The value is a guide when SMC's series LC1 controller is used and may vary depending on the driver capacity.

Non-standard Motors: The following motors will be mounted when a motor mounted type is specified.

	Motor output (W)	Power supply voltage (VAC)	Motor model	Compatible driver model
Matsushita Electric Industrial Co., Ltd.	100	100/115	MSM011P1A	MSD011P1E
		200/230	MSM012P1A	MSD013P1E
Mitsubishi Electric Corporation	100	100/115	HC-PQ13	MR-C10A1
		200/230		MR-C10A
Yaskawa Electric Corporation	100	100/115	SGME-01BF12	SGDE-01BP
		200/230	SGME-01AF12	SGDE-01AP

* For motor mounting dimensions, refer to the dimensions on page 182 as a reference for mounting and design.

* Refer to pages starting with 205 for driver dimensions, etc. Furthermore, for detailed specifications, etc., contact each motor manufacturer.

* For a non-standard motor specification, when the motor is mounted before shipping, the driver is included but the cable that connects the motor and driver is optional. Refer to page 178 for part numbers.

Non-standard Motor
Horizontal Mount

Series LG1 H21
With Coupling

Motor Output
100W

High Rigidity
Direct Acting
Guide

Rolled Ball Screw
 $\varnothing 15\text{mm}/10\text{mm}$ lead

How to Order

LG1 H21 G 2 1 NA — Stroke — F W — X10

• Frame material

Nil	Aluminum alloy
T	Stainless steel

• Motor specification

G	Matsushita Electric Industrial Co., Ltd.
R	Mitsubishi Electric Corporation
Y	Yaskawa Electric Corporation

• Power supply voltage

1	100/115VAC (50/60Hz)
2	200/230VAC (50/60Hz)
0	Without motor

• Switch

Nil	None
W	N.C. (B contact) 2 pcs.

Specifications

Standard stroke		mm	100	200	300	400		
Performance	Body weight	Aluminum (without motor)	kg	5.2	6.0	6.8	7.6	
		Stainless steel (without motor)	kg	8.4	9.7	10.9	12.2	
	Operating temperature range	°C					5 to 40 (with no condensation)	
	Work load	kg		30				
	Maximum speed	mm/s		500				
	Positioning repeatability	mm		±0.05				
Main parts	Motor	AC servomotor (100W)						
	Encoder	Incremental system						
	Lead screw	Rolled ball screw $\varnothing 15\text{mm}$, 10mm lead						
	Guide	High rigidity direct acting guide						
	Motor/Screw connection	With coupling						
Switch	Model	Photo micro sensor EE-SX674 (Refer to page 319 for details.)						
	Specifications	5 to 24VDC Load current (1C): 100mA, Internal voltage drop: 0.8V or less Load current (1C): 40mA, Internal voltage drop: 0.4V or less						

Intermediate strokes

Strokes other than the standard strokes on the left are available by special order. Consult SMC.

Allowable Moment (N·m)

Allowable static moment

Pitching	142
Rolling	79
Yawing	150

m : Transfer load (kg)

a : Work piece acceleration (mm/s²)

Me: Dynamic moment

L : Overhang to work piece center of gravity (mm)

Allowable dynamic moment

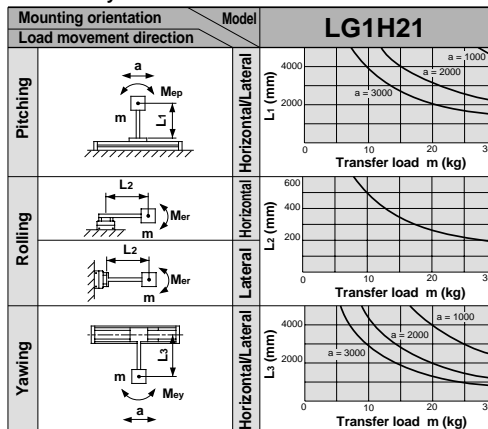

Refer to page 183 for deflection data.

Non-standard Motor/Horizontal Mount Specification **Series LG1□H21**

Dimensions/LG1□H21□2□NA (X10)

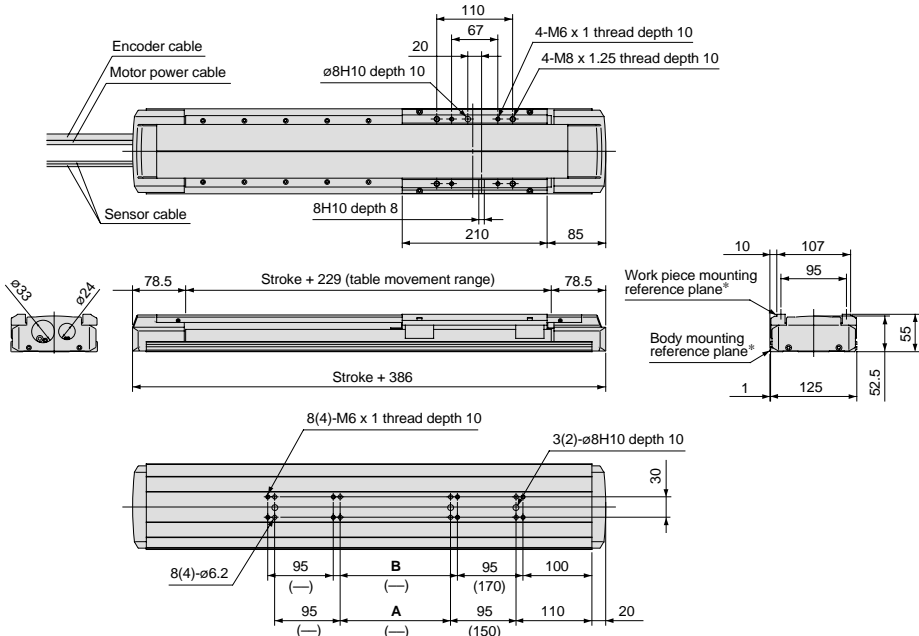

Model	Stroke	A	B
LG1□H21□2□NA-100-F□-X10*	100	—	—
LG1□H21□2□NA-200-F□-X10	200	60	80
LG1□H21□2□NA-300-F□-X10	300	160	180
LG1□H21□2□NA-400-F□-X10	400	260	280

* Dimensions inside () are for a 100 mm stroke.

* The body mounting reference plane and work piece mounting reference plane should be used as standards when mounting onto equipment. Refer to pages starting with 181 for mounting.

Positioning Time Guide

Positioning distance (mm)	Positioning time (sec.)					
	1	10	100	200	400	
Speed (mm/s)	10	0.5	1.4	10.4	20.4	40.4
	100	0.5	0.6	1.5	2.5	4.5
	250	0.5	0.6	0.9	1.3	2.1
	500	0.5	0.6	0.8	1.0	1.4

* Values will vary slightly depending on the operating conditions.

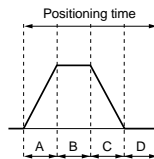

A: Acceleration time
 B: Constant velocity time
 C: Deceleration time
 D: Resting time (0.4sec.)*
 Maximum acceleration: 3000mm/s²
 * The value is a guide when SMC's series LCI controller is used and may vary depending on the driver capacity.

Non-standard Motors: The following motors will be mounted when a motor mounted type is specified.

	Motor output (W)	Power supply voltage (VAC)	Motor model	Compatible driver model
Matsushita Electric Industrial Co., Ltd.	100	100/115	MSM011P1A	MSD011P1E
		200/230	MSM012P1A	MSD013P1E
Mitsubishi Electric Corporation	100	100/115	HC-PQ13	MR-C10A1
		200/230		MR-C10A
Yaskawa Electric Corporation	100	100/115	SGME-01BF12	SGDE-01BP
		200/230	SGME-01AF12	SGDE-01AP

* For motor mounting dimensions, refer to the dimensions on page 182 as a reference for mounting and design.

* Refer to pages starting with 205 for driver dimensions, etc. Furthermore, for detailed specifications, etc., contact each motor manufacturer.

* For a non-standard motor specification, when the motor is mounted before shipping, the driver is included but the cable that connects the motor and driver is optional. Refer to page 178 for part numbers.

Non-standard Motor
Horizontal Mount

Series LG1 H21
With Coupling

Motor Output
100W

High Rigidity
Direct Acting
Guide

Rolled Ball Screw
 $\varnothing 15\text{mm}/20\text{mm}$ lead

How to Order

LG1 H21 G 2 1 NC Stroke F W X10

Frame material

Nil	Aluminum alloy
T	Stainless steel

Motor specification

G	Matsushita Electric Industrial Co., Ltd.
R	Mitsubishi Electric Corporation
Y	Yaskawa Electric Corporation

Power supply voltage

1	100/115VAC (50/60Hz)
2	200/230VAC (50/60Hz)
0	Without motor

Switch

Nil	None
W	N.C. (B contact) 2 pcs.

Specifications

		Standard stroke	mm	500	600	700	800	900	1000
Performance	Body weight	Aluminum (without motor)	kg	8.4	9.2	10.0	10.8	11.6	12.4
		Stainless steel (without motor)	kg	13.4	14.7	15.9	17.2	18.4	19.7
	Operating temperature range	°C 5 to 40 (with no condensation)							
	Work load	kg 30							
	Maximum speed ^{Note)}	mm/s 1000 1000 930 740 600 500							
	Positioning repeatability	mm ± 0.05							
Main parts	Motor	AC servomotor (100W)							
	Encoder	Incremental system							
	Lead screw	Rolled ball screw $\varnothing 15\text{mm}$, 20mm lead							
	Guide	High rigidity direct acting guide							
	Motor/Screw connection	With coupling							
Switch	Model	Photo micro sensor EE-SX674 (Refer to page 319 for details.)							
	Specifications	5 to 24VDC Load current (1C): 100mA, Internal voltage drop: 0.8V or less Load current (1C): 40mA, Internal voltage drop: 0.4V or less							

Intermediate strokes

Strokes other than the standard strokes on the left are available by special order. Consult SMC.

Note) The speed is limited by the transfer load. Contact each motor manufacturer regarding the maximum speeds for each transfer load.

Allowable Moment (N·m)

Allowable static moment

Pitching	142
Rolling	79
Yawing	150

m : Transfer load (kg)

a : Work piece acceleration (mm/s²)

Me: Dynamic moment

L : Overhang to work piece center of gravity (mm)

Allowable dynamic moment

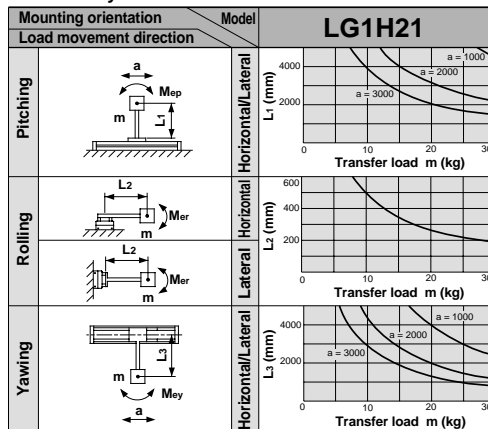

Refer to page 183 for deflection data.

Non-standard Motor/Horizontal Mount Specification **Series LG1□H21**

Dimensions/LG1□H21□2□NC (X10)

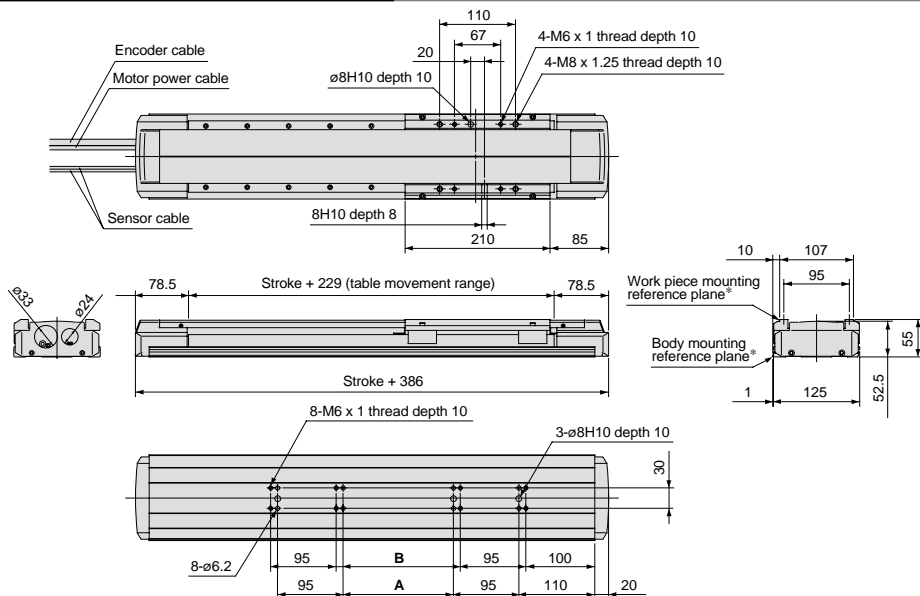

Model	Stroke	A	B
LG1□H21□2□NC-500-F□-X10	500	360	380
LG1□H21□2□NC-600-F□-X10	600	460	480
LG1□H21□2□NC-700-F□-X10	700	560	580
LG1□H21□2□NC-800-F□-X10	800	660	680
LG1□H21□2□NC-900-F□-X10	900	760	780
LG1□H21□2□NC-1000-F□-X10	1000	860	880

* The body mounting reference plane and work piece mounting reference plane should be used as standards when mounting onto equipment.
Refer to pages starting with 181 for mounting.

Positioning Time Guide

Positioning distance (mm)	Positioning time (sec.)					
	1	10	100	500	1000	
Speed (mm/s)	10	0.5	1.5	10.5	50.5	100.5
	100	0.5	0.6	1.5	5.5	10.5
	500	0.5	0.6	0.9	1.7	2.7
	1000	0.5	0.6	0.9	1.4	1.9

* Values will vary slightly depending on the operating conditions.

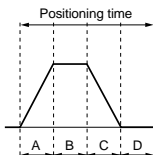

A: Acceleration time
B: Constant velocity time
C: Deceleration time
D: Resting time (0.4sec.)*
Maximum acceleration: 2000mm/s²

* The value is a guide when SMC's series LCI controller is used and may vary depending on the driver capacity.

Non-standard Motors: The following motors will be mounted when a motor mounted type is specified.

	Motor output (W)	Power supply voltage (VAC)	Motor model	Compatible driver model
Matsushita Electric Industrial Co., Ltd.	100	100/115	MSM011P1A	MSD011P1E
		200/230	MSM012P1A	MSD013P1E
Mitsubishi Electric Corporation	100	100/115	HC-PQ13	MR-C10A1
		200/230		MR-C10A
Yaskawa Electric Corporation	100	100/115	SGME-01BF12	SGDE-01BP
		200/230	SGME-01AF12	SGDE-01AP

* For motor mounting dimensions, refer to the dimensions on page 182 as a reference for mounting and design.

* Refer to pages starting with 205 for driver dimensions, etc. Furthermore, for detailed specifications, etc., contact each motor manufacturer.

* For a non-standard motor specification, when the motor is mounted before shipping, the driver is included but the cable that connects the motor and driver is optional. Refer to page 178 for part numbers.

Non-standard Motor
Horizontal Mount

Series LG1 H21
With Coupling

Motor Output
100W

High Rigidity
Direct Acting
Guide

Slide Screw
 $\varnothing 20\text{mm}/20\text{mm}$ lead

How to Order

LG1 H21 G 2 1 SC Stroke F W X10

Frame material

Nil	Aluminum alloy
T	Stainless steel

Motor specification

G	Matsushita Electric Industrial Co., Ltd.
R	Mitsubishi Electric Corporation
Y	Yaskawa Electric Corporation

Power supply voltage

1	100/115VAC (50/60Hz)
2	200/230VAC (50/60Hz)
0	Without motor

Switch

Nil	None
W	N.C. (B contact) 2 pcs.

Specifications

		Standard stroke	mm	100	200	300	400	500	600	700	800	900	1000	1200
Performance	Body weight	Aluminum (without motor)	kg	5.8	6.7	7.5	8.4	9.3	10.2	11.1	11.9	12.8	13.7	15.9
		Stainless steel (without motor)	kg	9.3	10.7	12.0	13.5	14.8	16.2	17.5	19.0	20.3	21.7	25.2
	Operating temperature range	°C 5 to 40 (with no condensation)												
	Work load	kg 15												
	Maximum speed	mm/s 500												
Main parts	Positioning repeatability	mm ± 0.1												
	Motor	AC servomotor (100W)												
	Encoder	Incremental system												
	Lead screw	Slide screw $\varnothing 20\text{mm}$, 20mm lead												
	Guide	High rigidity direct acting guide												
Switch	Motor/Screw connection	With coupling												
	Model	Photo micro sensor EE-SX674 (Refer to page 319 for details.)												
	Specifications	5 to 24VDC Load current (1C): 100mA, Internal voltage drop: 0.8V or less Load current (1C): 40mA, Internal voltage drop: 0.4V or less												

Intermediate strokes

Strokes other than the standard strokes above are available by special order. Consult SMC.

Allowable Moment (N·m)

Allowable static moment

Pitching	142
Rolling	79
Yawing	150

m : Transfer load (kg)
a : Work piece acceleration (mm/s²)
Me : Dynamic moment
L : Overhang to work piece center of gravity (mm)

Allowable dynamic moment

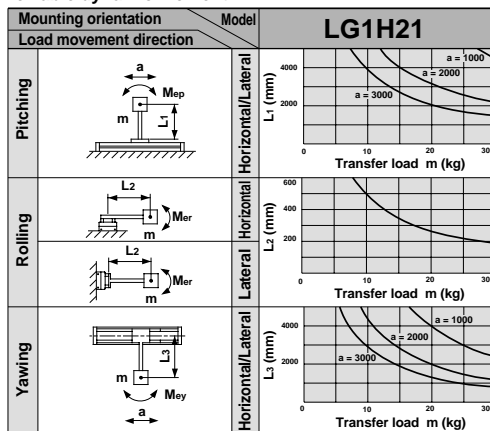

Refer to page 183 for deflection data.

Non-standard Motor/Horizontal Mount Specification **Series LG1□H21**

Dimensions/LG1□H21□2□SC (X10)

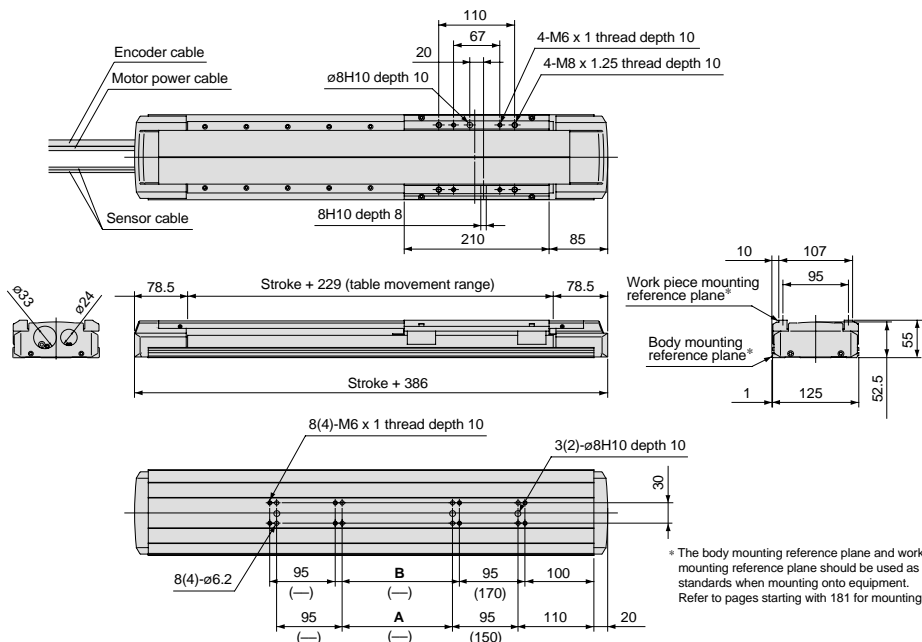

Model	Stroke	A	B
LG1□H21□2□SC- 100-F□-X10*	100	—	—
LG1□H21□2□SC- 200-F□-X10	200	60	80
LG1□H21□2□SC- 300-F□-X10	300	160	180
LG1□H21□2□SC- 400-F□-X10	400	260	280
LG1□H21□2□SC- 500-F□-X10	500	360	380
LG1□H21□2□SC- 600-F□-X10	600	460	480

* Dimensions inside () are for a 100 mm stroke.

Model	Stroke	A	B
LG1□H21□2□SC-700-F□-X10	700	560	580
LG1□H21□2□SC-800-F□-X10	800	660	680
LG1□H21□2□SC-900-F□-X10	900	760	780
LG1□H21□2□SC-1000-F□-X10	1000	860	880
LG1□H21□2□SC-1200-F□-X10	1200	1060	1080

Positioning Time Guide

Positioning distance (mm)		Positioning time (sec.)				
		1	10	100	600	1200
Speed (mm/s)	10	0.5	1.5	10.5	60.5	120.5
	100	0.5	0.6	1.5	6.5	12.5
	250	0.5	0.6	1.0	3.0	5.4
	500	0.5	0.6	0.9	1.9	3.1

* Values will vary slightly depending on the operating conditions.

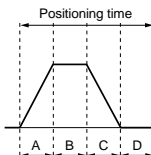

A: Acceleration time
B: Constant velocity time
C: Deceleration time
D: Resting time (0.4sec.)*
Maximum acceleration: 2000mm/s²

* The value is a guide when SMC's series LCI controller is used and may vary depending on the driver capacity.

Non-standard Motors: The following motors will be mounted when a motor mounted type is specified.

	Motor output (W)	Power supply voltage (VAC)	Motor model	Compatible driver model
Matsushita Electric Industrial Co., Ltd.	100	100/115	MSM011P1A	MSD011P1E
		200/230	MSM012P1A	MSD013P1E
Mitsubishi Electric Corporation	100	100/115	HC-PQ13	MR-C10A1
		200/230		MR-C10A
Yaskawa Electric Corporation	100	100/115	SGME-01BF12	SGDE-01BP
		200/230	SGME-01AF12	SGDE-01AP

* For motor mounting dimensions, refer to the dimensions on page 182 as a reference for mounting and design.

* Refer to pages starting with 205 for driver dimensions, etc. Furthermore, for detailed specifications, etc., contact each motor manufacturer.

* For a non-standard motor specification, when the motor is mounted before shipping, the driver is included but the cable that connects the motor and driver is optional. Refer to page 178 for part numbers.

Series LG1H Options

Actuator cable

This cable connects the actuator and the controller.
(Included with the actuator)

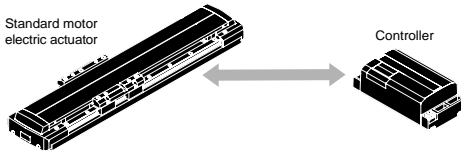

How to Order

LG1-1-B **02**

● Cable length

02	2m
03	3m
04	4m
05	5m

Non-standard motor cables

These cables are used to connect non-standard motors and drivers.
Cable lengths other than those shown below should be arranged by the customer.

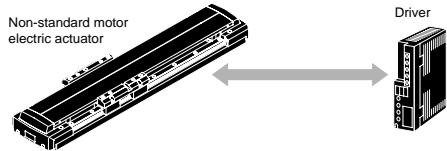

How to Order

LG1-1-**G** **05**

● Compatible model

G	Matsushita Electric Industrial Co., Ltd.
R	Mitsubishi Electric Corporation
Y	Yaskawa Electric Corporation

● Cable length

05	5m
-----------	----

Applicable cables

Model	Manufacturer part no.
LG1-1-G05 *1	MFMCA0050AEB (for motor)
	MFECA0050EAB (for encoder)
LG1-1-R05	(for motor) *2
	MR-JCCBL5M (for encoder)
LG1-1-Y05 *3	DP9320081-2 (for motor)
	DP9320089-2 (for encoder)

* 1 When the Matsushita Electric Industrial Co., Ltd. motor driver is selected, in addition to the cable, a power connector (MOLEX 5569-10R) and an interface connector (Sumitomo/3-M Limited 10126-3000VE) are also required.

* 2 A cable is not provided for the Mitsubishi Electric Corporation motor, and therefore the customer should arrange a 4 core, 0.75mm² electric cable.

* 3 When the Yaskawa Electric Corporation motor driver is selected, a digital operator and PC are required for selecting the various parameters.

Please refer to the technical literature of each manufacturer for further details.

Series LG1H Construction

Construction/ Without coupling

LG1H20

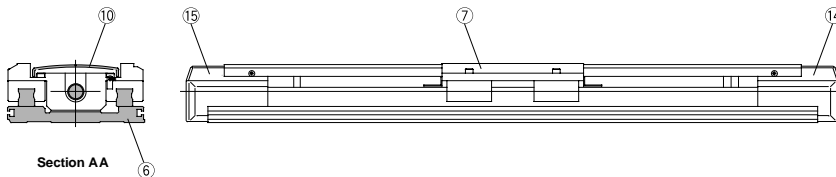
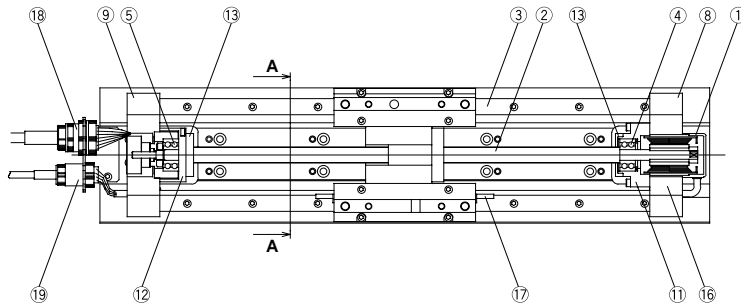

Parts list

No.	Description	Material	Note
1	AC servomotor	—	100W
2	Lead screw	—	Ball screw/Slide screw
3	High rigidity direct acting guide	—	
4	Bearing R	—	
5	Bearing F	—	
6	Body	Aluminum alloy/Stainless steel	
7	Table	Aluminum alloy	
8	Housing A	Aluminum alloy	
9	Housing B	Aluminum alloy	
10	Top cover	Aluminum alloy	

No.	Description	Material	Note
11	Head cover	Aluminum alloy	
12	Encoder cover	Aluminum alloy	
13	Bumper	IIR	
14	End cover A	PC	
15	End cover B	PC	
16	Photo micro sensor	—	
17	Sensor plate	—	
18	Connector A	—	
19	Connector B	—	

Series LG1H Construction

Construction/ Without coupling

LG1H21

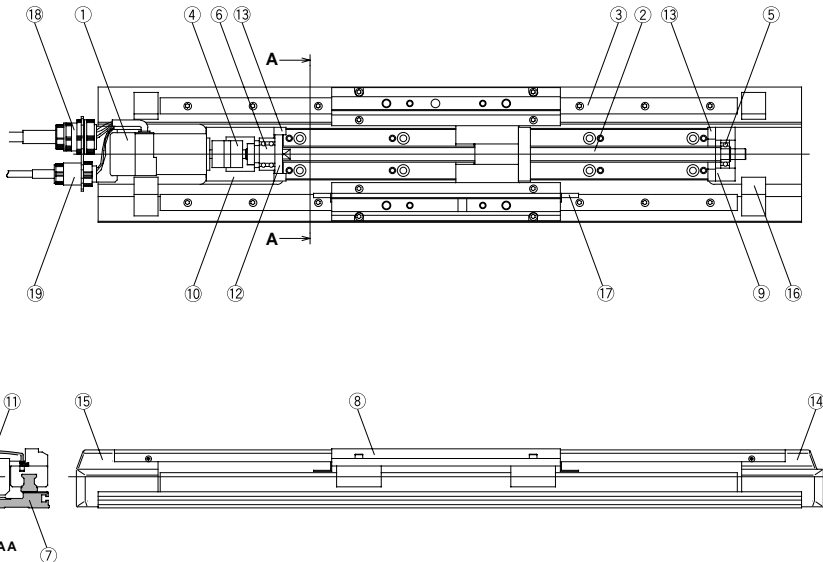

Parts list

No.	Description	Material	Note
1	AC servomotor	—	100W
2	Lead screw	—	Ball screw/Slide screw
3	High rigidity direct acting guide	—	
4	Coupling	—	
5	Bearing R	—	
6	Bearing F	—	
7	Body	Aluminum alloy/Stainless steel	
8	Table	Aluminum alloy	
9	Housing A	Aluminum alloy	
10	Housing B	Aluminum alloy	

No.	Description	Material	Note
11	Top cover	Aluminum alloy	
12	Bearing retainer	Aluminum alloy	
13	Bumper	IIR	
14	End cover A	PC	
15	End cover B	PC	
16	Photo micro sensor	—	
17	Sensor plate	—	
18	Connector A	—	
19	Connector B	—	

Series LG1H Mounting

Top Mount

LG1H20/ Without coupling

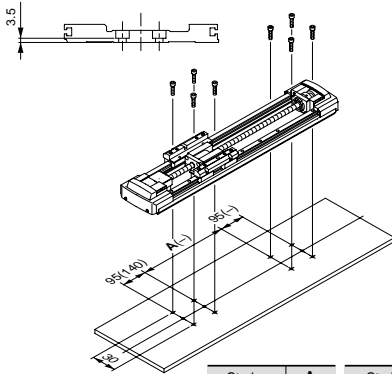

Stroke	A	Stroke	A
100	—	700	550
200	50	800	650
300	150	900	750
400	250	1000	850
500	350	1200	1050
600	450		

Dimensions inside () are for a 100 mm stroke.

LG1H21/ With coupling

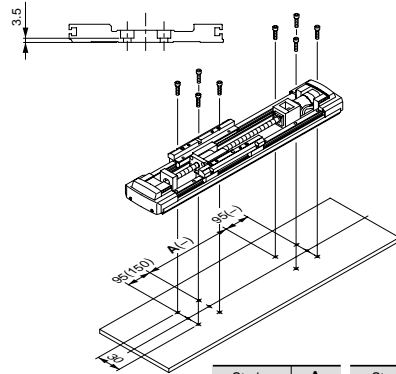

Stroke	A	Stroke	A
100	—	700	560
200	60	800	660
300	160	900	760
400	260	1000	860
500	360	1200	1060
600	460		

Dimensions inside () are for a 100 mm stroke.

Bottom Mount

LG1H20/ Without coupling

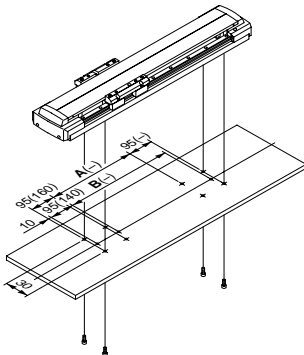

Stroke	A	B	Stroke	A	B
100	—	—	700	570	645
200	70	145	800	670	745
300	170	245	900	770	845
400	270	345	1000	870	945
500	370	445	1200	1070	1145
600	470	545			

Dimensions inside () are for a 100 mm stroke.

LG1H21/ With coupling

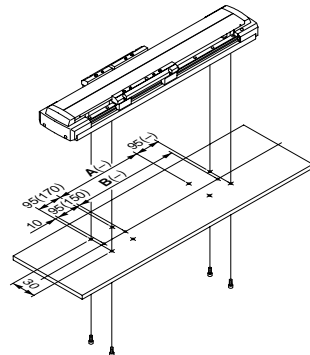

Stroke	A	B	Stroke	A	B
100	—	—	700	580	655
200	80	155	800	680	755
300	180	255	900	780	855
400	280	355	1000	880	955
500	380	455	1200	1080	1155
600	480	555			

Dimensions inside () are for a 100 mm stroke.

LJ1

LG1

LC1

LX

LC6D/LC6C

Switches

Series LG1H Non-standard Motor Mounting Dimensions

Non-standard Motor Mounting Dimensions/ With Coupling

LG1H21

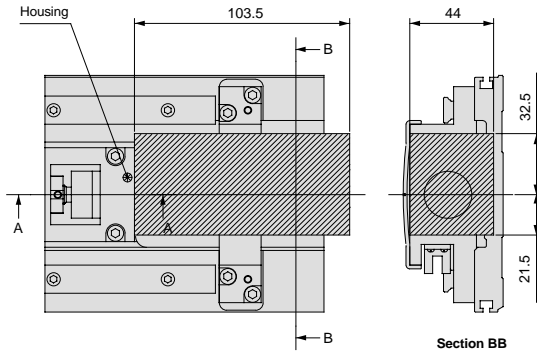

Motor mounting area dimensions

Manufacturer	Mitsubishi Electric Corporation Yaskawa Electric Corporation	Matsushita Electric Industrial Co., Ltd.
Thread size	M4 x 0.7	M3 x 0.5
Effective thread length (mm)	8	6
Quantity	2	4
P.C.D.	46	45

 Motor mounting area

* When mounting a coupling on the motor, mount it within the dimensional range shown on the left.

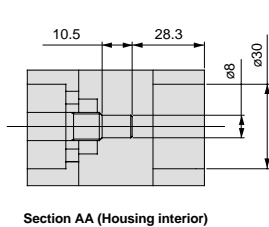

Section AA (Housing interior)

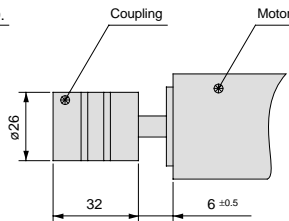
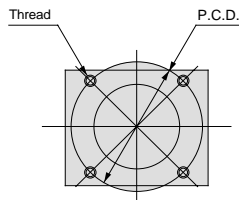

Coupling mounting dimensions

Series LG1H Deflection Data

Deflection Data

The load and the amount of deflection at load point W are shown in the graphs below.

LG1H/ Aluminum body

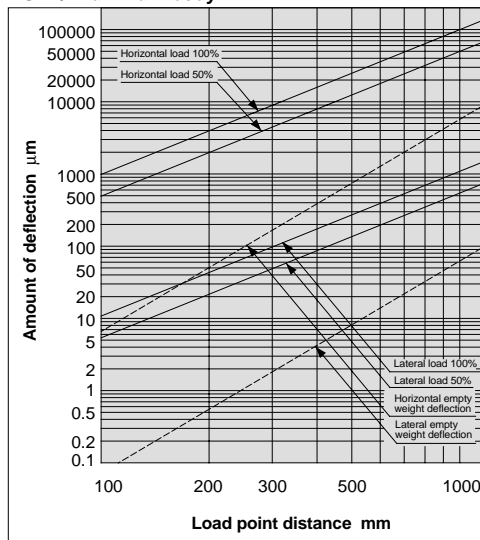

LG1TH/ Stainless steel body

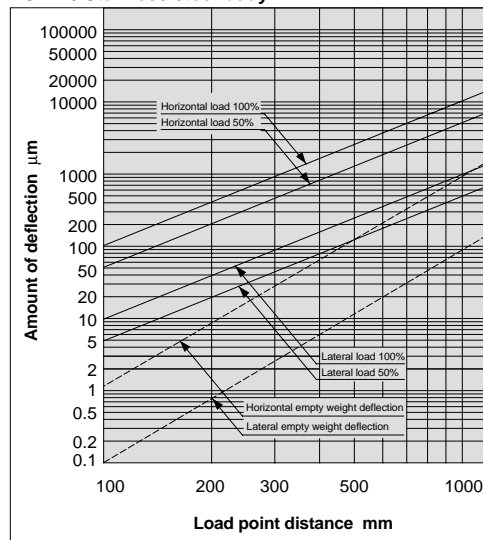

With single end support and table moved to the end of the stroke

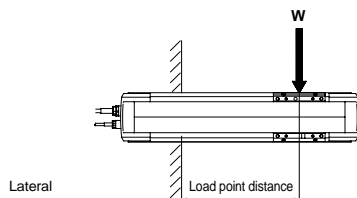
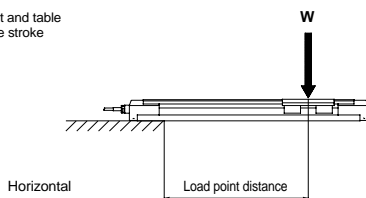

LJ1

LG1

LC1

LX

LC6D/LC6C

Switches