

Speed Controller with Residual Pressure Release Valve with One-touch Fitting

Series AS□□□□FE

Elbow Type/Universal Type

Residual pressure can be easily released with one push of button.

Eye-catching red color release button.



JIS Symbol

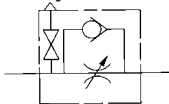

Flow Direction Symbols on Body

	Meter-out type	Meter-in type
Symbol		
JIS Symbol		

Model

Elbow type	Universal type	Port size in the cylinder side	Applicable tubing O.D. (mm)					Applicable cylinder bore size (mm)
			ø4	ø6	ø8	ø10	ø12	
AS22□1FE-01	AS23□1FE-01	R 1/8	●	●	●	● ⁽¹⁾		20, 25, 32
AS22□1FE-02	AS23□1FE-02	R 1/4	●	●	●	●		20, 25, 32, 40
AS32□1FE-03	AS33□1FE-03	R 3/8		●	●	●	●	40, 50, 63
AS42□1FE-04	AS43□1FE-04	R 1/2				●	●	63, 80, 100

Note 1) Elbow type only

Note 2) Distinction between meter-out/meter-in types by appearance

Those are distinguished by the lock nut. The meter-out type is electroless nickel plated, while the meter-in type is black zinc chromate plated.

Specifications

Fluid	Air
Proof pressure	1.5 MPa
Max. operating pressure	1.0 MPa
Min. operating pressure	0.1 MPa
Ambient and fluid temperature	-5 to 60°C (No freezing)
Number of needle rotations	10 turns
Effective area of residual exhaust valve	0.8 mm ²
Applicable tubing material	Nylon, Soft nylon, Polyurethane

Flow Rate and Effective Area

Model		AS22□1FE-01 AS23□1FE-01		AS22□1FE-02 AS23□1FE-02			AS32□1FE AS33□1FE			AS42□1FE AS43□1FE	
Tubing O.D.	Metric size	ø4	ø6 ø8 ø10	ø4	ø6	ø8 ø10	ø6	ø8	ø10 ø12	ø10	ø12
Controlled flow (Free flow)	Flow rate (l/min (ANR))	180	230	260	390	460	660	790	920	1580	1710
	Effective area (mm ²)	2.7	3.5	4	6	7	10	12	14	24	26

Note) Flow rate values are measured at 0.5 MPa and 20°C.

How to Order

AS 2 2 1 1 FE 01-06 S K

- Body size**
 - 2 1/8, 1/4 standard
 - 3 3/8 standard
 - 4 1/2 standard
- Type**
 - 2 Elbow
 - 3 Universal
- Control type**
 - 0 Meter-out
 - 1 Meter-in
- Port size**
 - 01 R 1/8
 - 02 R 1/4
 - 03 R 3/8
 - 04 R 1/2
- Applicable tubing O.D. (mm)**
 - 04 ø4
 - 06 ø6
 - 08 ø8
 - 10 ø10
 - 12 ø12
- Hexagonal lock nut**
- With seal**
- With residual pressure release valve**
- With One-touch fitting**

**Speed Controller with Residual Pressure
Release Valve with One-touch Fitting, Elbow Type/Universal Type**

Needle Valve/Flow Characteristics

**AS2201FE-01, AS2211FE-01
AS2301FE-01, AS2311FE-01**

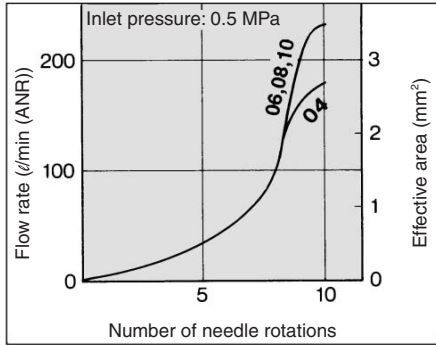

**AS2201FE-02, AS2211FE-02
AS2301FE-02, AS2311FE-02**

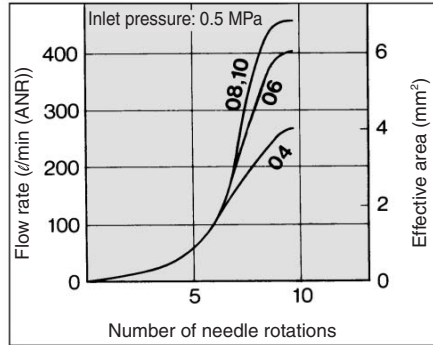

**AS3201FE, AS3211FE
AS3301FE, AS3311FE**

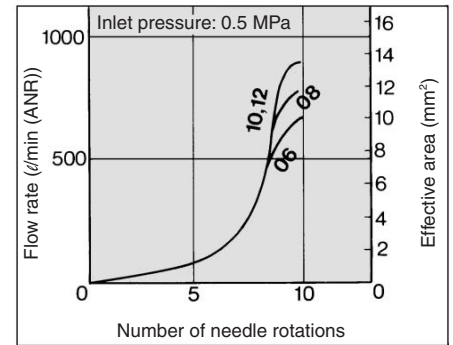

**AS4201FE, AS4211FE
AS4301FE, AS4311FE**

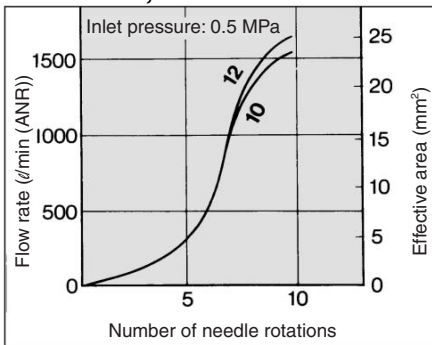

⚠ Caution

Be sure to read before handling. Refer to pages 15-18-3 to 15-18-4 for Safety Instructions and Common Precautions on the products mentioned in this catalog, and refer to pages 15-8-6 to 15-8-8 for Precautions on every series.

- AS
- ASP
- ASN
- AQ
- ASV
- AK
- ASS
- ASR
- ASF

Construction

Elbow type, Meter-out type

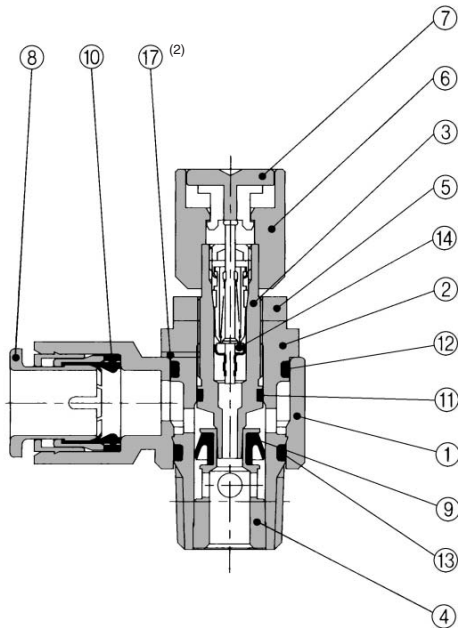

Meter-in type

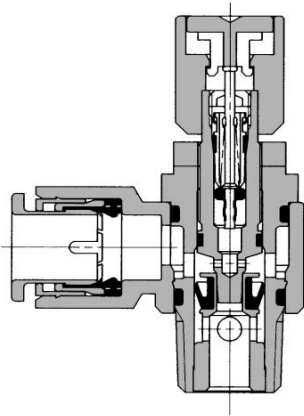

Universal type Meter-out type

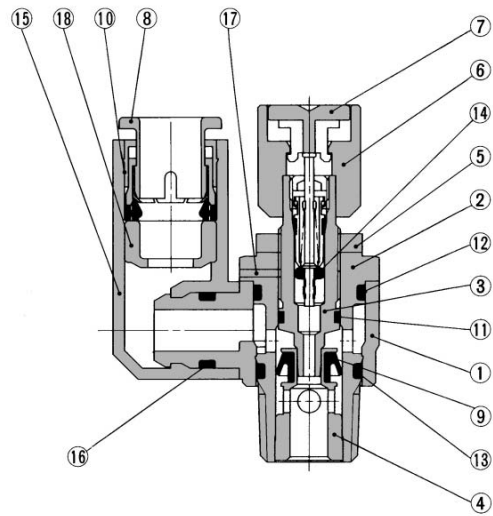

Meter-in type

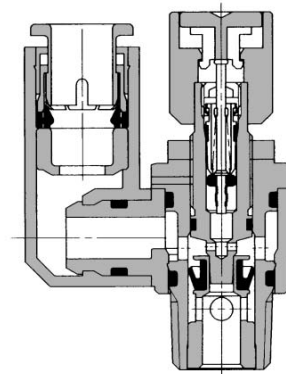

Component Parts

No.	Description	Material	Note
①	Body A	PBT	White
②	Body B	Brass	Electroless nickel plated
③	Needle	Brass	Electroless nickel plated
④	Seat ring	Brass	⁽¹⁾
⑤	Lock nut	Brass	Electroless nickel plated ⁽²⁾
⑥	Handle	Aluminum alloy	Red painted
⑦	Push button	POM	Red
⑧	Cassette	POM, Stainless steel	
⑨	U seal	NBR	
⑩	Seal	NBR	
⑪	O-ring	NBR	
⑫	O-ring	NBR	
⑬	O-ring	NBR	
⑭	Valve core	NBR, Brass, Stainless steel	
⑮	Elbow body	PBT	
⑯	O-ring	NBR	
⑰	Accidental release prevention screw	Stainless steel	AS2□□1FE-01 ⁽³⁾
⑱	Spacer	PBT ⁽⁴⁾	

Note 1) AS2□□1FE type is electroless nickel plated.
Note 2) Meter-in type is black zinc chromate plated.

Note 3) Only for AS2□□1FE-01.
Note 4) AS23□1FE-01 (ø4, ø6) is POM.

Speed Controller with Residual Pressure Release Valve with One-touch Fitting, Elbow Type/Universal Type

Dimensions

Elbow type

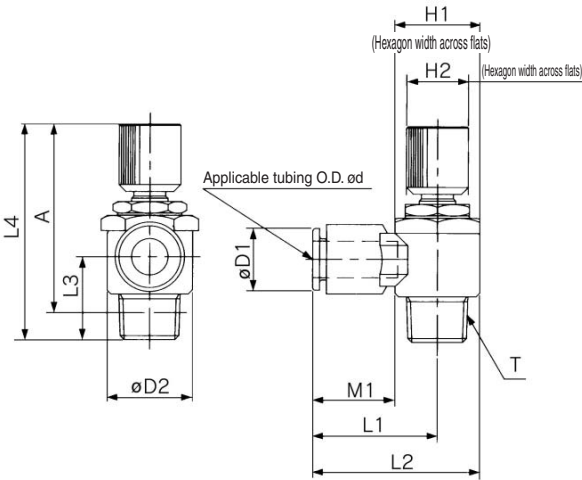

Model	Applicable tubing O.D. ød	T	H1	H2	D1	D2	L1	L2	L3	L4		A*		M1	Weight (g)
										Max.	Min.	Max.	Min.		
AS22□1FE-01-04SK	4	R 1/8	12	12	9.3	14.2	20.4	27.5	14.3	53.9	48.9	49.9	44.9	12.7	26
AS22□1FE-01-06SK	6				11.6		20.4	27.5						13.5	27
AS22□1FE-01-08SK	8				15.2		25.3	32.4						18.5	29
AS22□1FE-01-10SK	10				18.5	33.1	40.2	15						21	31
AS22□1FE-02-04SK	4	R 1/4	17	14	10.4	18.5	25.2	34.4	18.2	52.2	47.2	46.2	41.2	16	36
AS22□1FE-02-06SK	6				12.8		25.2	34.4						17	37
AS22□1FE-02-08SK	8				15.2		27.2	36.4						18.5	39
AS22□1FE-02-10SK	10				18.5	33.9	43.2	20						21	42
AS32□1FE-03-06SK	6	R 3/8	19	14	12.8	23	27.8	39.3	20.9	57.8	52.8	51.5	46.5	16	57
AS32□1FE-03-08SK	8				15.2		29.5	41						18.5	60
AS32□1FE-03-10SK	10				18.5		31.9	43.3						21	62
AS32□1FE-03-12SK	12				20.9	32.8	44.3							22	64
AS42□1FE-04-10SK	10	R 1/2	24	17	18.5	28.6	33.6	47.9	25.4	64.7	59.7	56.5	51.5	21	103
AS42□1FE-04-12SK	12				20.9		34.6	48.9						22	105

* Reference dimensions of R thread after installation.

Dimensions

Universal type

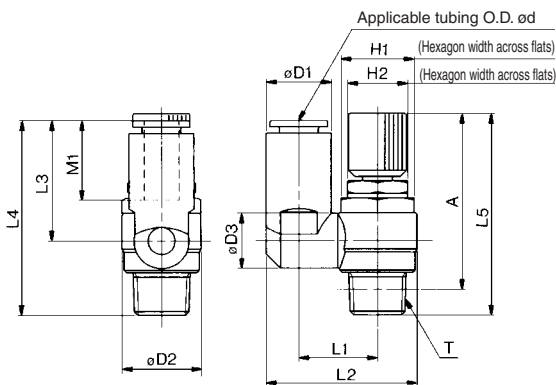

Model	Applicable tubing O.D. ød	T	H1	H2	D1	D2	D3	L1	L2	L3	L4	L5		A*		M1	Weight (g)
												Max.	Min.	Max.	Min.		
AS23□1FE-01-04SK	4	R 1/8	12	12	9.3	14.2	9.3	13.1	24.9	17.5	31.8	53.9	48.9	49.9	44.9	12.7	26
AS23□1FE-01-06SK	6				11.6		10.9	14	26.9	22.9	37.2					13.5	27
AS23□1FE-01-08SK	8				15.2		12.9	16.2	30.9	28.2	41.7					18.5	29
AS23□1FE-02-04SK	4	R 1/4	14	14	10.4	18.5	10.9	16.2	30.6	21.9	40.1	52.2	47.2	46.2	41.2	16	36
AS23□1FE-02-06SK	6				12.8		18.4	34	25.2	42.6	17					37	
AS23□1FE-02-08SK	8				15.2		12.9	18.3	35.2	28.2	45.6					18.5	39
AS23□1FE-02-10SK	10				18.5	20.2	38.7	31	48.4						21	42	
AS33□1FE-03-06SK	6	R 3/8	19	14	12.8	23	12.9	20.6	38.5	25.2	46.1	57.8	52.8	51.5	46.5	17	57
AS33□1FE-03-08SK	8				15.2		39.7	28.2	49.1	18.5	60						
AS33□1FE-03-10SK	10				18.5		43.7	32.6	53.5	21	62						
AS33□1FE-03-12SK	12				20.9	44.9	34.4	55.3							22	64	
AS43□1FE-04-10SK	10	R 1/2	24	17	18.5	28.6	16.2	25.8	49.4	32.6	58	64.7	59.7	56.5	51.5	21	103
AS43□1FE-04-12SK	12				21.7		19.4	26.8	52	36.3	61.7					22	105

* Reference dimensions of R thread after installation.

AS

ASP

ASN

AQ

ASV

AK

ASS

ASR

ASF