

Speed Controller: Standard Type

Series AS

In-line Type

Compact size saves space.
Speed may be accurately controlled even at low speeds.
Constant speed easily set.
Retainer prevents an accidental loss of needle.

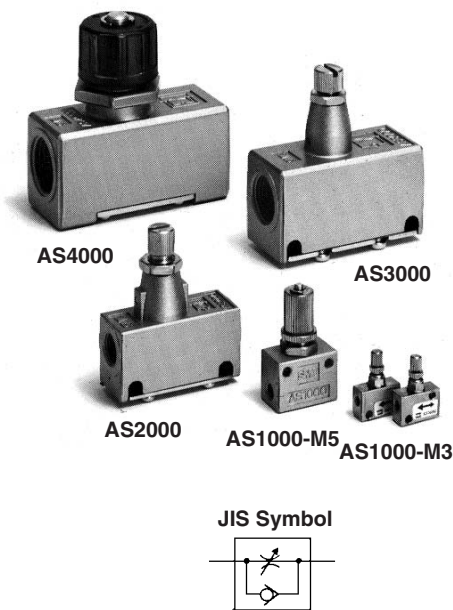

Model/Flow Rate and Effective Area

Model	Port size	Free flow		Controlled flow		Applicable cylinder bore size (mm)	Weight (g)
		Flow rate (l/min (ANR))	Effective area (mm ²)	Flow rate (l/min (ANR))	Effective area (mm ²)		
AS1000-M3	M3 x 0.5	20	0.3	20	0.3	2.5, 4, 6	4.7
AS1000-M5	M5 x 0.8	90	1.4	80	1.2	6, 10, 16, 20, 25	33
AS2000-01	1/8	340	5.2	250	3.8	20, 25, 32, 40	90
AS2000-02	1/4	340	5.2	250	3.8		115
AS3000-02	1/4	810	12.3	810	12.3	32, 40, 50, 63	130
AS3000-03	3/8	810	12.3	810	12.3		124
AS4000-02	1/4	1,670	25.5	1,670	25.5	40, 50, 63 80, 100	221
AS4000-03	3/8	1,670	25.5	1,670	25.5		214
AS4000-04	1/2	1,670	25.5	1,670	25.5		205
AS5000-02	1/4	2,840	44	2,840	44	40, 50, 63 80, 100	242
AS5000-03	3/8	4,270	66	4,270	66		233
AS5000-04	1/2	4,270	66	4,270	66		224

Note) Flow rate values are measured at 0.5 Mpa and 20°C.

Specifications

Fluid	Air
Proof pressure note)	1.5 MPa (1.05 MPa)
Max. operating pressure note)	1 MPa (0.7 MPa)
Min. operating pressure note)	0.05 MPa (0.1 MPa)
Ambient and fluid temperature	-5 to 60°C (No freezing)
Number of needle rotations note)	8 turns (10 turns)

Note) (): Values for AS1000.

Accessory

Description	Part no.	Applicable model
Nipple	M-5N	AS1000

Note) AS1000 with nipple: AS1000-M5-N

How to Order

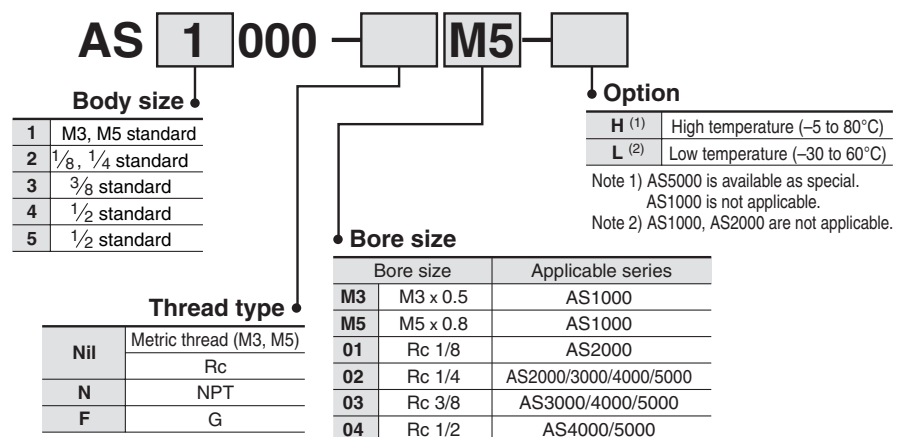

⚠ Caution

Be sure to read before handling. Refer to pages 15-18-3 to 15-18-4 for Safety Instructions and Common Precautions on the products mentioned in this catalog, and refer to pages 15-8-6 to 15-8-8 for Precautions on every series.

Needle Valve/Flow Characteristics

AS1000-M3

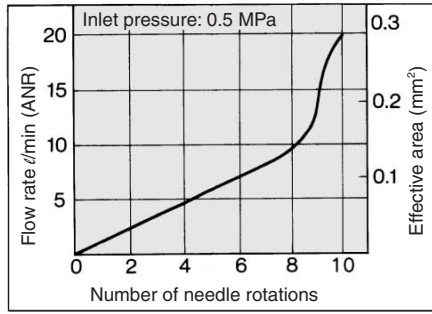

AS1000-M5

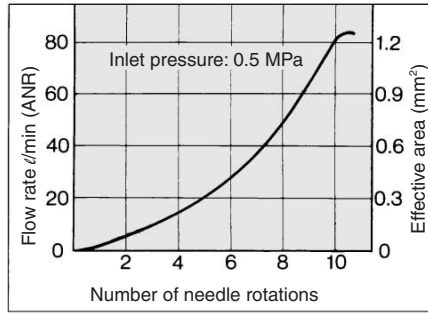

AS2000

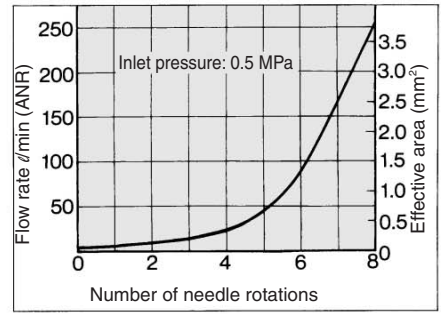

AS3000

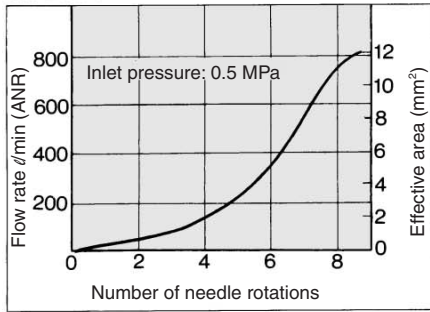

AS4000

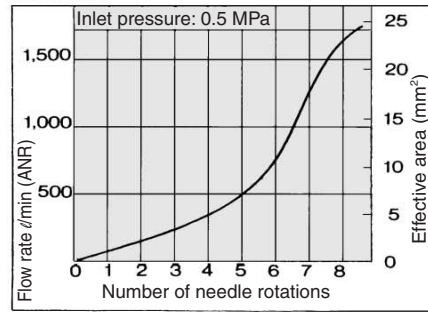

AS5000

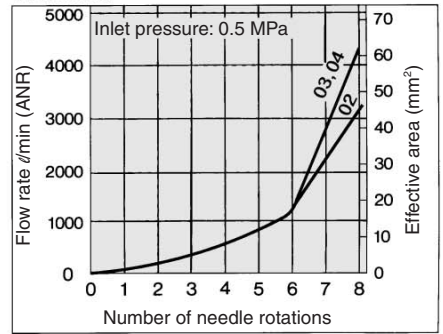

Construction: AS1000-M3

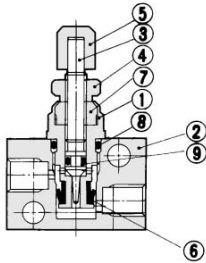

Component Parts

No.	Description	Material	Note
①	Body B	Brass	Electroless nickel plated
②	Body	Brass	Electroless nickel plated
③	Needle	Brass	Electroless nickel plated
④	Lock nut	Brass	Electroless nickel plated
⑤	Handle	Brass	Electroless nickel plated
⑥	U seal	HNBR	
⑦	Needle guide	Brass	Electroless nickel plated
⑧	O-ring	NBR	4.5 x 3 x 0.75
⑨	O-ring	NBR	2.2 x 0.8 x 0.7

Construction: AS1000-M5

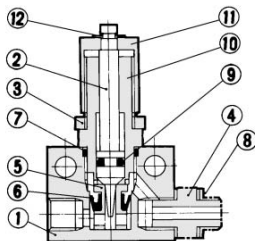

Component Parts

No.	Description	Material
①	Body	Zinc alloy
②	Needle	Stainless steel
③	Lock nut *	Brass
④	Nipple	Stainless steel

* Electroless nickel plated

No.	Description	Material	Note
⑨	O-ring	NBR	
⑩	Needle guide	Brass	Electroless nickel plated
⑪	Handle	Brass	Electroless nickel plated
⑫	E type snap ring	Steel	Black oxidized coated

Replacement Parts

No.	Description	Material	Part no.
⑤	Valve seat	Brass	1429138
⑥	U seal	HNBR	142964
⑦	O-ring	NBR	ø9 x ø7 x ø1
⑧	Gasket	PVC	M-5G1

- AS
- ASP
- ASN
- AQ
- ASV
- AK
- ASS
- ASR
- ASF

Series AS

Construction: AS2000/3000

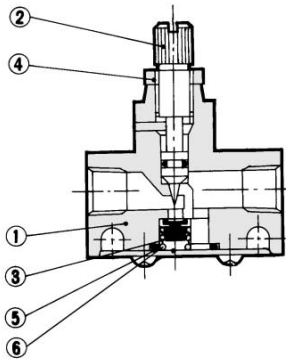

Component Parts

No.	Description	Model	
		AS2000	AS3000
①	Body	Zinc alloy	Aluminum alloy
②	Needle *	Brass	Brass
④	Lock nut *	Brass	Carbon steel

Replacement Parts

No.	Description	Model	
		AS2000	AS3000
③	Valve	143022	14283
⑤	O-ring	143021	14284
⑥	Spring	143023	14282

* Electroless nickel plated

Construction: AS4000

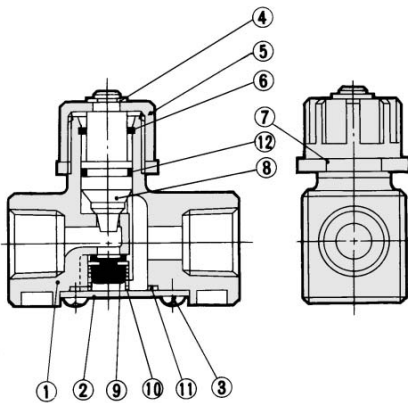

Component Parts

No.	Description	Material	Note
①	Body	Aluminum alloy	Chromated
②	Cap	Rolled steel	Zinc chromated
③	Cross-recessed head cap screw	Steel wire	4 x 0.7 x 8
④	E type snap ring	Stainless steel	JIS B 2805 Nominal 6
⑤	Handle	Zinc alloy	Black zinc chromate plated
⑥	Ring	Steel wire	Zinc chromated
⑦	Lock nut	Zinc alloy	
⑧	Needle	Aluminum alloy	
⑫	O-ring	NBR	143112

Replacement Parts

No.	Description	Material	Parts no.
⑨	Valve	NBR, Brass	143145
⑩	Spring	Stainless steel	143146
⑪	O-ring	NBR	143147

Construction: AS5000

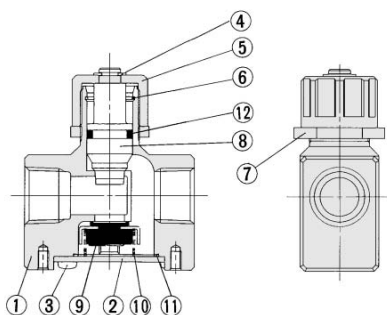

Component Parts

No.	Description	Material	Note
①	Body	Aluminum alloy	Chromated
②	Cap	Rolled steel	Nickel plated
③	Cross-recessed head cap screw	Steel wire	M4 x 0.7 x 8 Nickel plated
④	E type snap ring	Stainless steel	JIS B 2805 Nominal 6
⑤	Handle	Zinc alloy	Chromated
⑥	Ring	Stainless steel	
⑦	Lock nut	Zinc alloy	Chromated
⑧	Needle	Aluminum alloy	Chromated
⑫	O-ring	NBR	JIS B 2401 P12

Replacement Parts

No.	Description	Material	Parts no.
⑨	Valve	NBR, Stainless steel	14143
⑩	Spring	Stainless steel	14144
⑪	Seal	NBR	14147

Speed Controller: Standard Type In-line Type **Series AS**

Dimensions: AS1000-M3

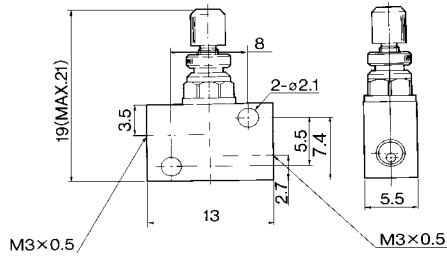

Dimensions: AS1000-M5

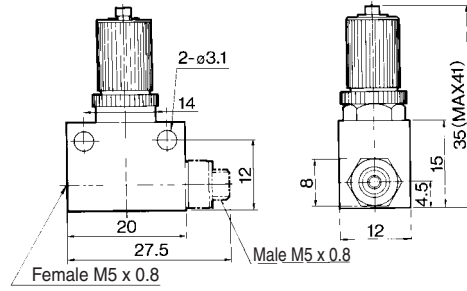

Dimensions: AS2000/3000

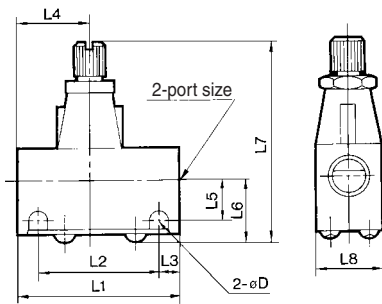

Dimensions: AS4000

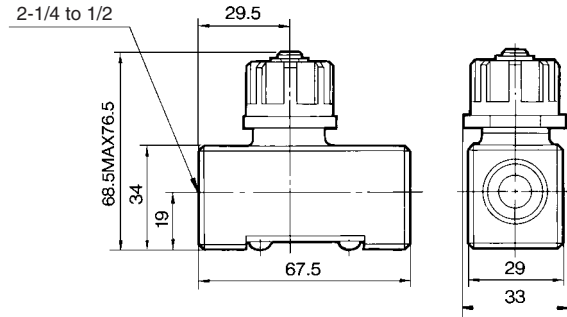

Dimensions

Model	Bore size	L1	L2	L3	L4	L5	L6	L7		L8	D
								Max.	Min.		
AS2000-01	Rc 1/8	40	30	5	17	10	15.5	54.5	50	16	4.5
AS2000-02	Rc 1/4	40	30	5	23	11.5	17	56	51.5	20	4.5
AS3000-02, 03	Rc 1/4, 3/8	56	45.5	5.25	25	13.2	20.6	68	61	26	5.5

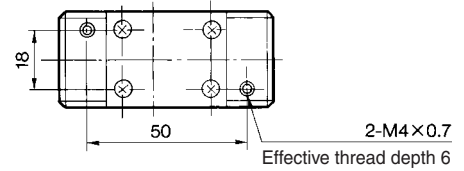

Dimensions: AS5000

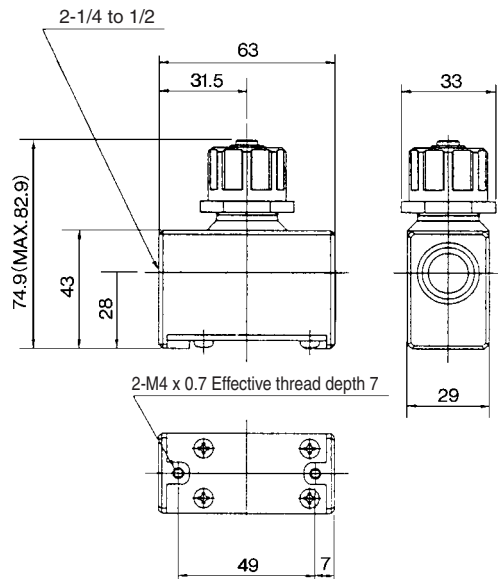

- AS
- ASP
- ASN
- AQ
- ASV
- AK
- ASS
- ASR
- ASF