

Related Products: AHC System/Auto Hand Changing System Series MA

AHC System Auto Hand Changing System Series MA

The robot hand tools change automatically to accommodate workpieces of different shapes, thus making it possible to adopt the FMS (flexible manufacturing system) in the assembly line.



Specifications

Series	MA210	MA310	MA311	MA320	MA321
Positioning	Ball coupling			Curved coupling	
Max. transportable weight	3 kg	5 kg			
Handling	Single acting/Air supply at separation		Double acting	Single acting/Air supply at separation	Double acting
Handling air pressure	0.4 to 0.7 MPa				
Proof pressure	1.05 MPa				
Ambient and fluid temperature	0 to 60°C				
Positioning repeatability	±0.01 mm				

System Construction

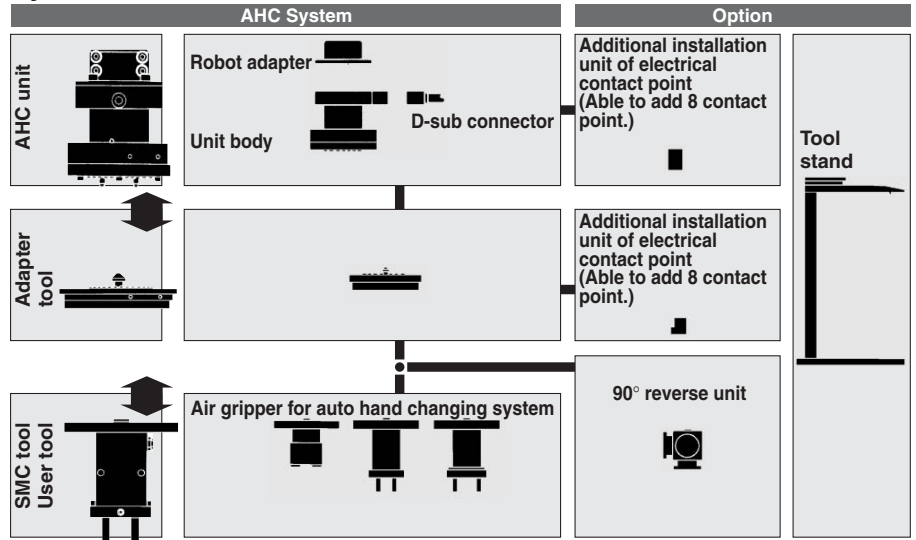

Variations

Adapter for assembling robot
Series MA2
ø8, ø10, ø11, ø14, ø15, ø20
Series MA3
ø10, ø11, ø14, ø15, ø20,
ø24, ø25

Air grippers for auto hand changing system (ø10 to ø20)

Standard type
10D
MHZ2-16D
20D

Narrow type
10DN
MHZ2-16DN
20DN

Rotary actuated type
10
MHR2-15

Additional installation unit of electrical contact point (Able to add 8 contact points)

Added to the standard AHC unit

Added to the standard tool adapter
(Series MA3 only)

90° reverse unit

By attaching 2 tools, a single robot can perform 2 types of tasks. An auto switch for detecting the location can be mounted.

(Series MA3 only)

Tool stand

The height for setting a tool can be adjusted. An auto switch for detecting a tool can be mounted.

- MHZ
- MHF
- MHL
- MHR
- MHK
- MHS
- MHC
- MHT
- MHY
- MHW
- MRHQ
- Misc.
- D-
- 20-

Refer to "AHC system Series MA".