



Stainless Steel Heat Exchanger Type Air Dryer

Air Flow Capacity

Increased up to
40%

(Compared to the previous model)

Power Consumption

Reduced by up to
38%

(Compared to the previous model)

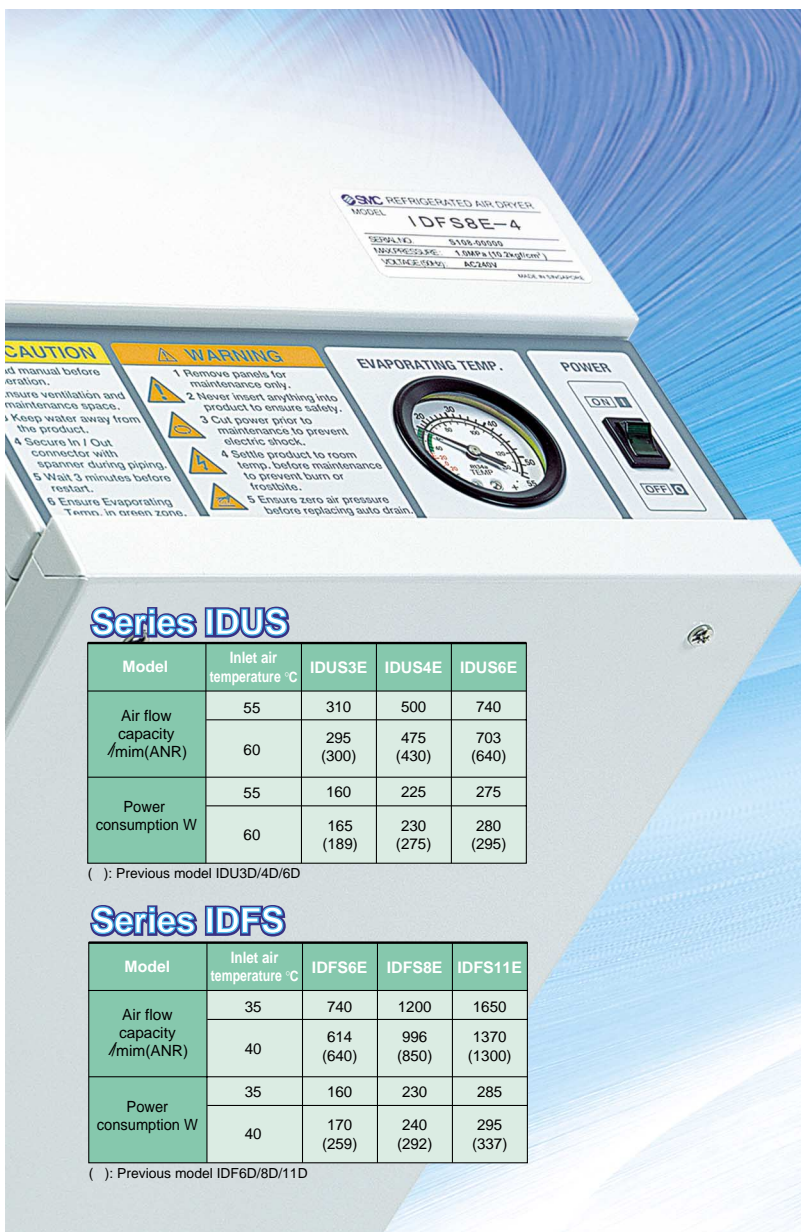

Series IDUS

Model	Inlet air temperature °C	IDUS3E	IDUS4E	IDUS6E
Air flow capacity /mim(ANR)	55	310	500	740
	60	295 (300)	475 (430)	703 (640)
Power consumption W	55	160	225	275
	60	165 (189)	230 (275)	280 (295)

() : Previous model IDU3D/4D/6D

Series IDFS

Model	Inlet air temperature °C	IDFS6E	IDFS8E	IDFS11E
Air flow capacity /mim(ANR)	35	740	1200	1650
	40	614 (640)	996 (850)	1370 (1300)
Power consumption W	35	160	230	285
	40	170 (259)	240 (292)	295 (337)

() : Previous model IDF6D/8D/11D

- Improved corrosion resistance with the use of stainless steel heat exchanger
- Standard evaporation thermometer facilitates daily inspection
- Compact heat exchanger reduces overall dimensions of the air dryer
- Environmentally friendly refrigerant R134a

Series IDUS/IDFS
(220/240VAC 50Hz)

Model Selection

- 1** Obtain the correction factor for the temperature from data A or B and the correction factor for the air pressure from data C.

Temperature Data A or B =

Series IDUS: Data A
Series IDFS: Data B

Air pressure Data C =
- 2** Calculate corrected air flow by using A or B and C.

Corrected air flow = (Air flow) ÷ (Data A x Data C)

Corrected air flow = (Air flow) ÷ (Data B x Data C)
- 3** Select a model having an air flow capacity that is higher than the corrected air flow.

IDUS selection example

The procedure for selecting the optimum model under the following conditions is shown below.

- Condition
- ① Inlet air temperature 55°C
 - ② Outlet air pressure dew point 10°C
 - ③ Ambient temperature 35°C
 - ④ Inlet air pressure 0.7MPa
 - ⑤ Air flow 350 /min (ANR)

- 1 A = 0.75 based on conditions ①, ② and ③
- 2 C = 1.00 based on condition ④
- 3 Based on condition ⑤, A and C
Corrected air flow = 350 ÷ (0.75 x 1.00) = 467 /min (ANR)
- 4 Based on condition ⑥;
IDUS4E is selected as the model to process an air flow larger than 467 /min (ANR) with a 50Hz power supply, according to data D-1.

Note) /min (ANR) is for reference conditions of 20°C, 1 ATM and 65% relative humidity.

IDFS selection example

The procedure for selecting the optimum model under the following conditions is shown below.

- Condition
- ① Inlet air temperature 35°C
 - ② Outlet air pressure dew point 10°C
 - ③ Ambient temperature 35°C
 - ④ Inlet air pressure 0.5MPa
 - ⑤ Air flow 1200 /min (ANR)

- 1 B = 0.95 based on conditions ①, ② and ③
- 2 C = 0.90 based on condition ④
- 3 Based on condition ⑤, B and C
Corrected air flow = 1200 ÷ (0.95 x 0.90) = 1400 /min (ANR)
- 4 Based on condition ⑥;
IDFS11E is selected as the model to process an air flow larger than 1400 /min (ANR) with a 60Hz power supply, according to data D-2.

Data A Correction factor for temperature (Series IDUS)

Inlet air temp. (°C) \ Ambient temp. (°C)		50			55			60			65			70			80		
		5	10	15	5	10	15	5	10	15	5	10	15	5	10	15	5	10	15
30		0.88	1.26	1.64	0.74	1.05	1.37	0.70	1.00	1.30	0.66	0.95	1.23	0.62	0.89	1.16	0.59	0.84	1.09
32		0.84	1.20	1.56	0.70	1.00	1.30	0.67	0.95	1.24	0.63	0.90	1.17	0.60	0.85	1.11	0.56	0.80	1.04
35		0.81	1.15	1.50	0.67	0.96	1.25	0.64	0.91	1.19	0.60	0.86	1.12	0.57	0.82	1.06	0.54	0.77	1.00
40		0.76	1.08	1.40	0.63	0.90	1.17	0.60	0.86	1.11	0.57	0.81	1.05	0.54	0.77	0.99	0.50	0.72	0.94

Data B Correction factor for temperature (Series IDFS)

Inlet air temp. (°C) \ Ambient temp. (°C)		30			35			40			45			50		
		5	10	15	5	10	15	5	10	15	5	10	15	5	10	15
30		0.92	1.31	1.71	0.74	1.05	1.37	0.59	0.84	1.09	0.48	0.68	0.89	0.40	0.58	0.75
32		0.88	1.25	1.63	0.70	1.00	1.30	0.46	0.83	1.04	0.46	0.65	0.85	0.39	0.55	0.72
35		0.84	1.20	1.56	0.67	0.96	1.25	0.37	0.77	1.00	0.44	0.62	0.81	0.37	0.53	0.69
40		0.79	1.13	1.46	0.63	0.90	1.17	0.28	0.72	0.94	0.41	0.59	0.76	0.35	0.50	0.64

Data C Correction factor for air pressure (Series IDUS)

Inlet air pressure (MPa)	0.15	0.2	0.3	0.4	0.5	0.6	0.7	0.8	0.9	1.0
Correction factor	0.65	0.68	0.77	0.84	0.90	0.95	1.00	1.03	1.06	1.08

Data D-1 Air flow capacity (Series IDUS)

Model	IDUS3E	IDUS4E	IDUS6E
Air flow capacity (/min (ANR))	310	500	740

Data D-2 Air flow capacity (Series IDFS)

Model	IDFS6E	IDFS8E	IDFS11E
Air flow capacity (/min (ANR))	740	1200	1650

Stainless Steel Heat Exchanger Type

Series *IDUS*

3E, 4E, 6E

How to Order

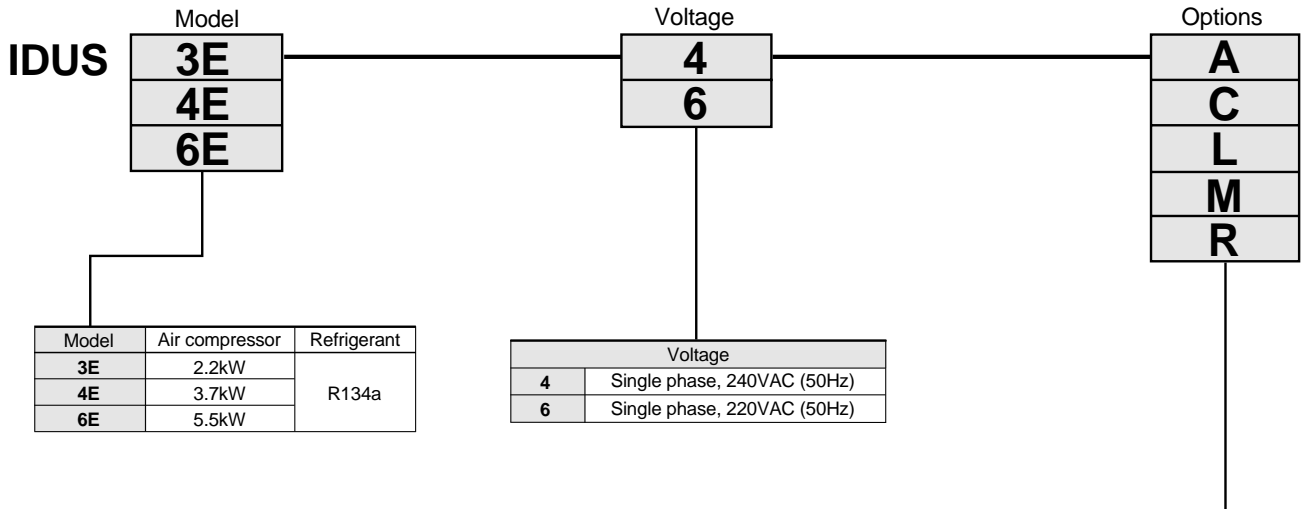

Model	Air compressor	Refrigerant
3E	2.2kW	R134a
4E	3.7kW	
6E	5.5kW	

Voltage	
4	Single phase, 240VAC (50Hz)
6	Single phase, 220VAC (50Hz)

Option	A	C	L	M	R
	With cool compressed air	With anti corrosive treatment	With heavy duty auto drain	With motor operated auto drain	With circuit breaker
Model					
IDUS3E	●	●	●	●	●
IDUS4E	●	●	●	●	●
IDUS6E	●	●	●	●	●

Note 1) All the options are not currently available. Please contact SMC if necessary.

Note 2) Refer to page 7 for further information of options.

Note 3) Combination of L and M is not available.

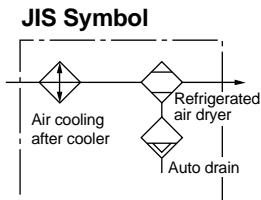

Standard Specifications/Models

Specification		Model	IDUS3E	IDUS4E	IDUS6E
Rated conditions	Air flow rate ^{Note 2)}	/min (ANR)	310	500	740
	Operating pressure	MPa	0.7		
	Inlet air temperature	°C	55		
	Ambient temperature	°C	32		
	Pressure dew point	°C	10		
Operating ranges	Working fluid		Compressed air		
	Inlet air pressure	MPa	0.15 to 1.0		
	Inlet air temperature	°C	2 to 80		
	Ambient temperature	°C	2 to 40 (Relative humidity of 85% or less)		
Electrical specifications	Power source	V	Single phase, 220VAC (50Hz), 240VAC (50Hz)		
	Power consumption	W	160	225	275
	Circuit breaker ^{Note 3)}	A	5		
Condenser			Air cooled		
Refrigerant			R134a		
Air connection	Rc		1/2		3/4
Drain connection			Outside diameter 10mm (One-touch fitting)		
Auto drain			AD44		
Weight	kg		27	33	35
Coating color			Munsell 10Y8/0.5 (White)		
Applicable compressor (screw type)	kW		2.2	3.7	5.5

Note 1) Select an air dryer according to the selection method and note the rated conditions.
 Note 2) The data for /min (ANR) refers to the conditions of 20°C, 1 atm. pressure and relative humidity of 65%.
 Note 3) Install a circuit breaker with sensitivity of ≤ 30mA.

Operation Principles

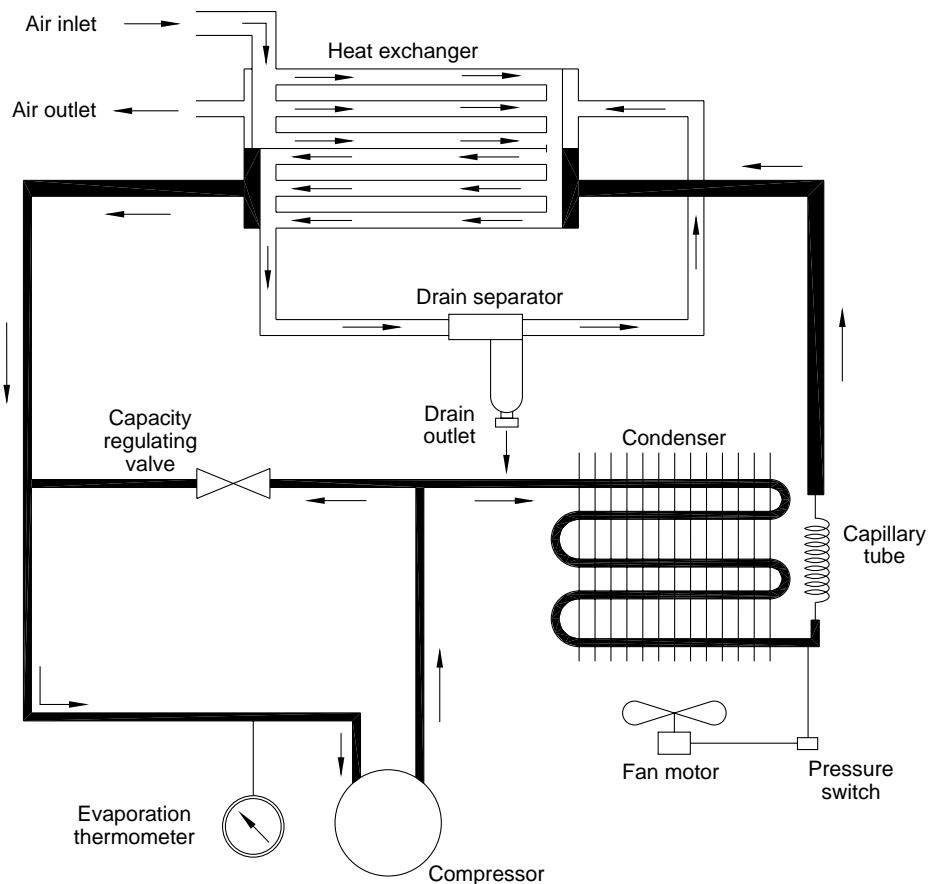

IDUS3E, 4E, 6E

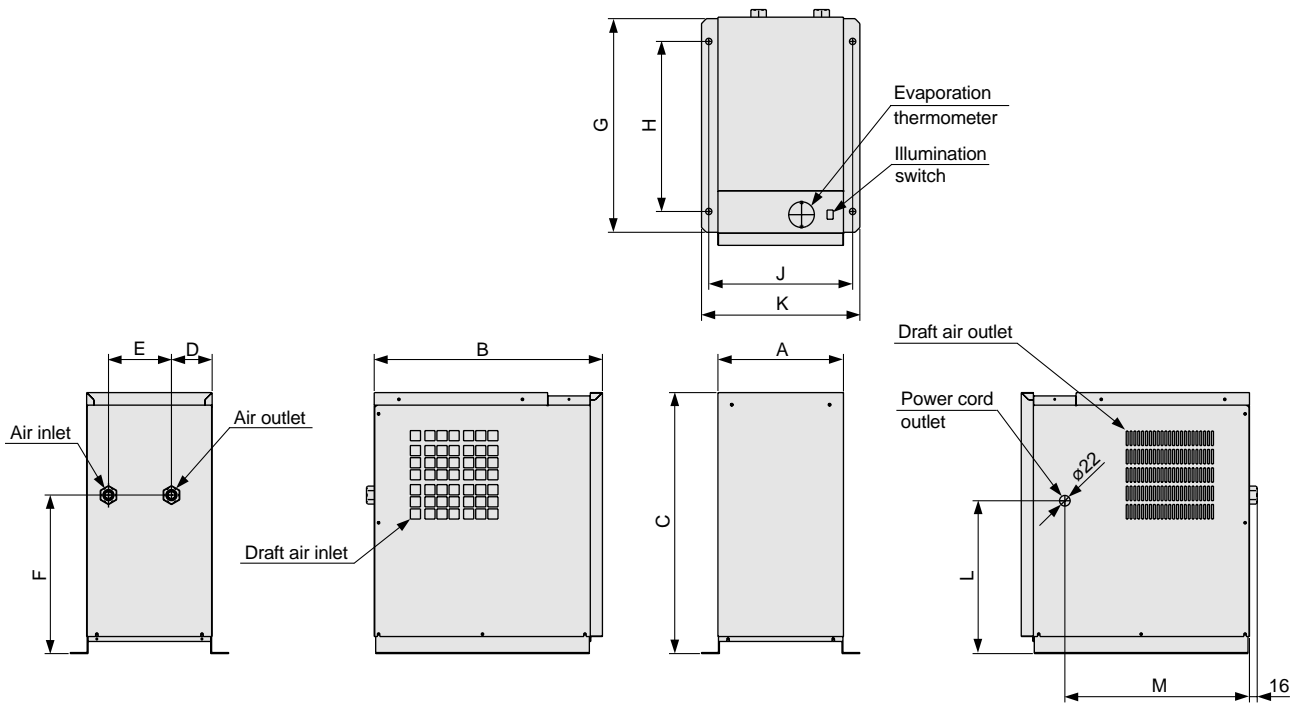

Model	Port size	A	B	C	D	E	F	G	H	J	K	L	M
IDUS3E	Rc 1/2	260	470	540	85	130	325	440	350	297	330	315	380
IDUS4E	Rc 1/2	260	560	540	85	130	325	530	440	297	330	315	470
IDUS6E	Rc 3/4	285	605	540	110	130	325	575	485	325	355	315	515

Note: The diagram above is drawn base on IDUS3E dimension with scale 1:6

Stainless Steel Heat Exchanger Type

Series *IDFS*

6E, 8E, 11E

How to Order

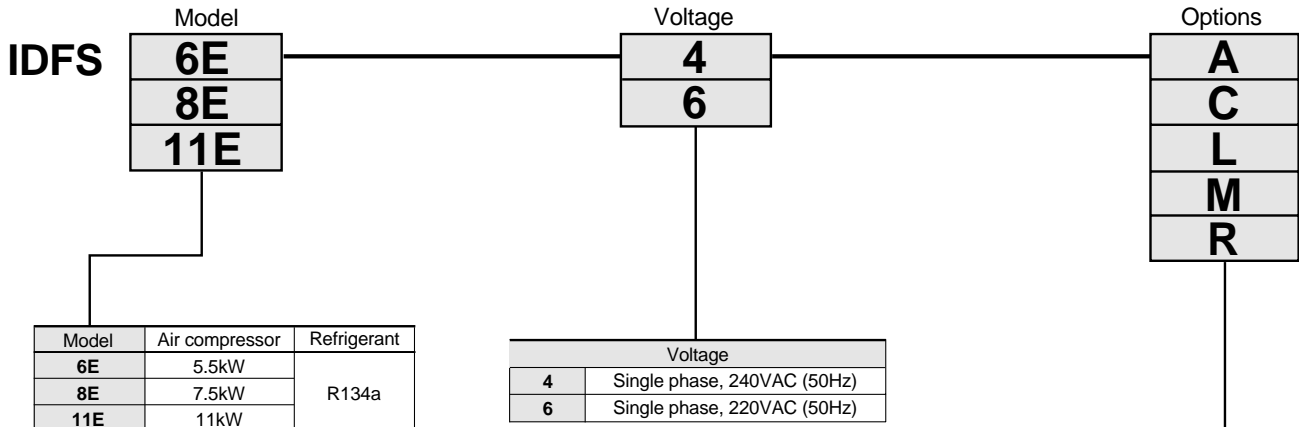

Option	A	C	L	M	R
	With cool compressed air	With anti corrosive treatment	With heavy duty auto drain	With motor operated auto drain	With circuit breaker
Model					
IDUF6E	●	●	●	●	●
IDUF8E	●	●	●	●	●
IDUF11E	●	●	●	●	●

Note 1) All the options are not currently available. Please contact SMC if necessary.

Note 2) Refer to page 7 for further information of options.

Note 3) Combination of L and M is not available.

Standard Specifications/Models



Specification		Model	IDFS6E	IDFS8E	IDFS11E
Rated conditions	Air flow rate ^{Note 2)}	/min (ANR)	740	1200	1650
	Operating pressure	MPa	0.7		
	Inlet air temperature	°C	35		
	Ambient temperature	°C	32		
	Pressure dew point	°C	10		
Operating conditions	Working fluid		Compressed air		
	Inlet air pressure	MPa	0.15 to 1.0		
	Inlet air temperature	°C	2 to 50		
	Ambient temperature	°C	2 to 40 (Relative humidity of 85% or less)		
Electrical specifications	Power source	V	Single phase, 220VAC (50Hz), 240VAC (50Hz)		
	Power consumption	W	160	230	285
	Circuit breaker	A	5		
Condenser ^{Note 3)}			Air cooled		
Refrigerant			R134a		
Air connection		Rc	3/4		
Drain connection			Diameter 10mm (One-touch fitting)		
Auto drain			AD44		
Weight		kg	27	33	35
Coating color			Munsell 10Y8/0.5 (White)		
Applicable compressor (screw type)		kW	5.5	7.5	11

JIS Symbol

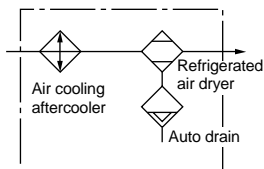

Note 1) Select an air dryer according to the selection method and note the rated conditions.

Note 2) The data for /min (ANR) refers to the conditions of 20°C, 1 atm. pressure and relative humidity of 65%.

Note 3) Install a circuit breaker with sensitivity of ≤ 30mA.

Operation Principles

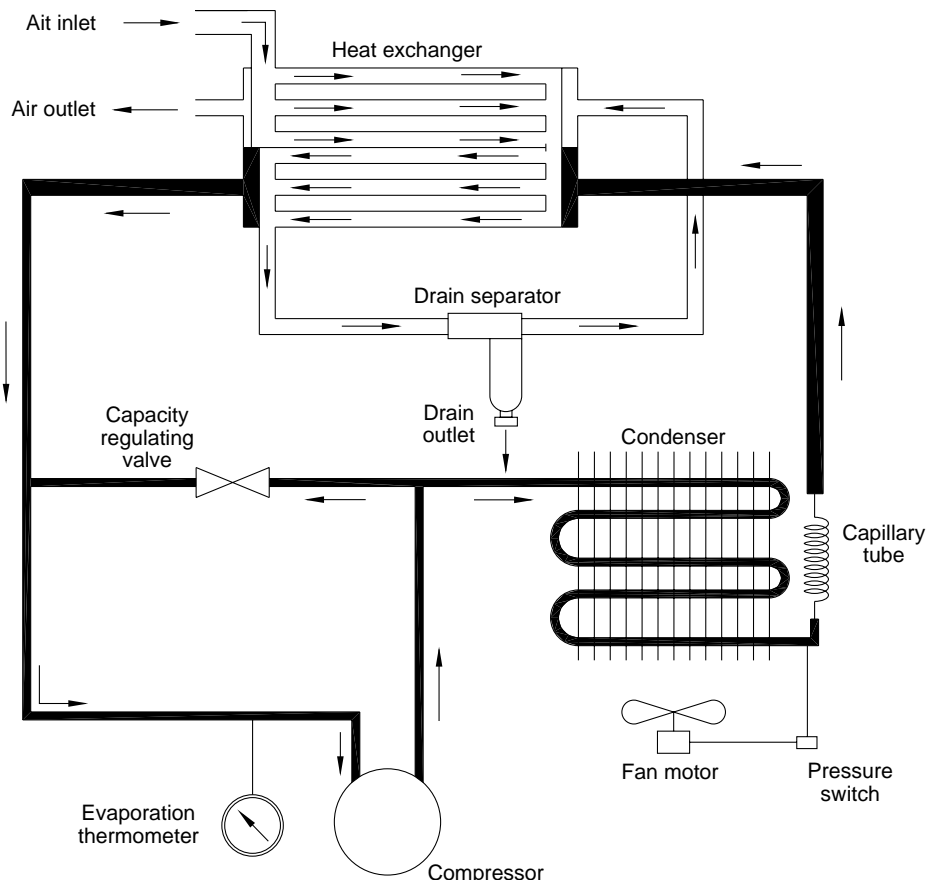

IDFS6E, 8E, 11E

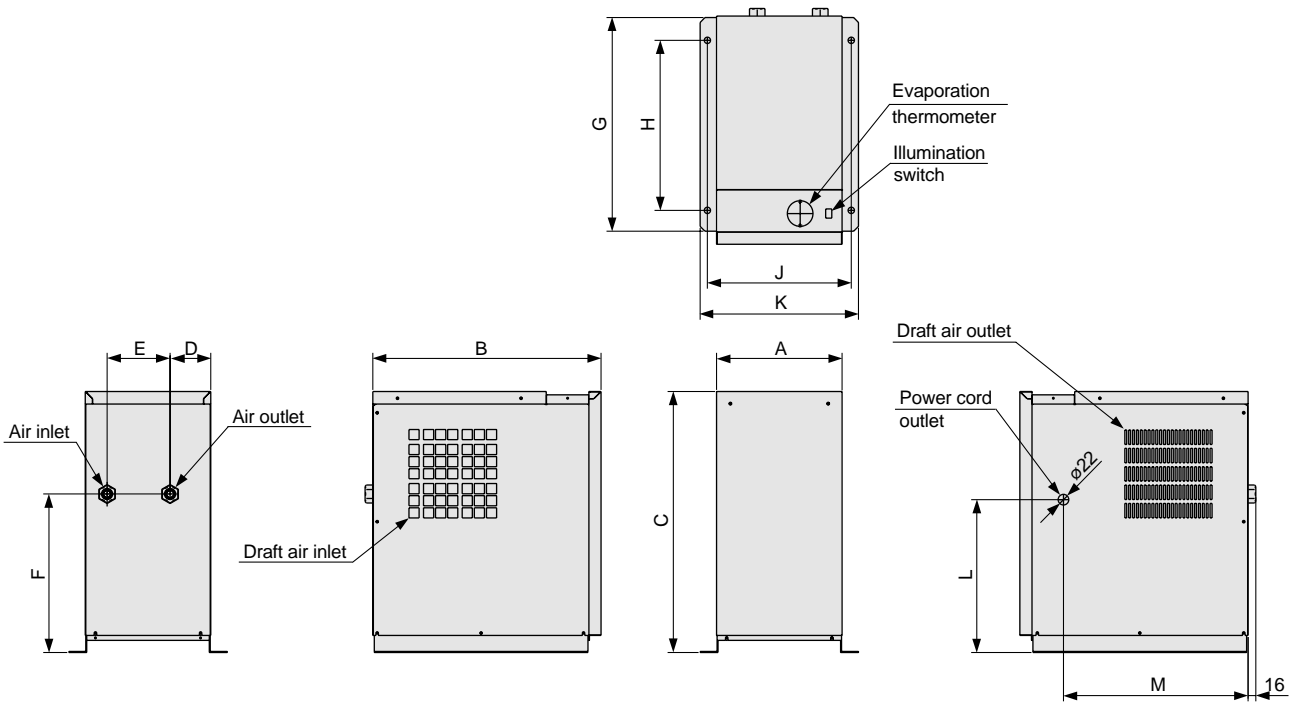

Model	Port size	A	B	C	D	E	F	G	H	J	K	L	M
IDFS6E	Rc 3/4	260	470	540	85	130	325	440	350	297	330	315	380
IDFS8E	Rc 3/4	260	560	540	85	130	325	530	440	297	330	315	470
IDFS11E	Rc 3/4	285	605	540	110	130	325	575	485	325	355	315	515

Note: The diagram above is drawn base on IDFS6E dimension with scale 1:6

Series IDUS/IDFS Option Specification

Refer to pages 1 and 5 for "How to Order" of options.

A Option symbol With cool compressed air

The air flow with this option is lower than that of the standard dryer.

Model	IDUS3E	IDUS4E	IDUS6E	IDFS6E	IDFS8E	IDFS11E
/min (ANR)	155	250	370	370	600	825

Condition

Inlet air pressure: 0.7MPa

Inlet air temperature: 35°C saturation

Ambient temperature: 32°C

Outlet air temperature: 10°C or less

C Option symbol With anti corrosive treatment

This minimizes the corrosion of the copper and copper alloy parts when the air dryer is used in an atmosphere containing hydrogen sulfide or sulfurous acid gas. This option extends the service life.

Special epoxy coating of copper tube and copper alloy parts.

The coating is not applied on the heat exchanger or around electrical parts, where operation may be affected by coating.

L Option symbol With heavy duty auto drain

A dryer with heavy duty auto drain (ADH4000-04) is installed instead of the float type auto drain (AD44).

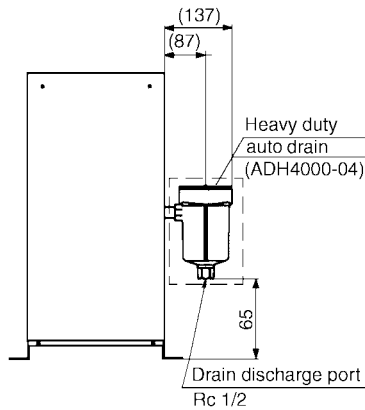

M Option symbol With motor operated auto drain

This option changes the float style auto drain (AD44) used by standard air dryers to a motor operated auto drain (ADM200-04) where by drainage is discharged more precisely.

Operating air pressure	Air discharge if no drainage
0.3MPa	6 / (ANR) each time
0.5MPa	10 / (ANR) each time
0.7MPa	14 / (ANR) each time

* Operation cycle: 1 cycle/min. Operation time: 2 sec./min.

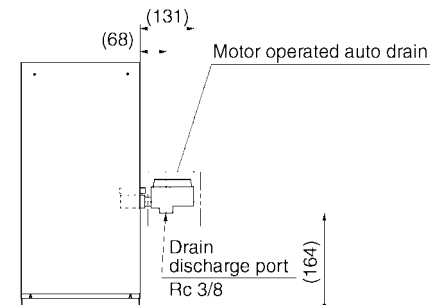

* Motor operated auto drain is packed together with main unit. Assembly is required.

R Option symbol With circuit breaker

A circuit breaker is attached to the side of the air dryer. This saves additional electrical wiring at the time of installation.

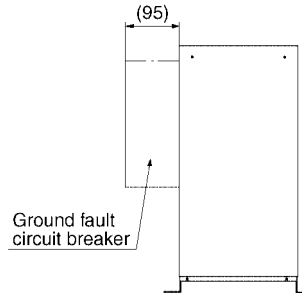

Breaker capacity	Sensitivity current
5A	15 to 30mA

Technical Data

Pressure dew point — Condensed water calculation

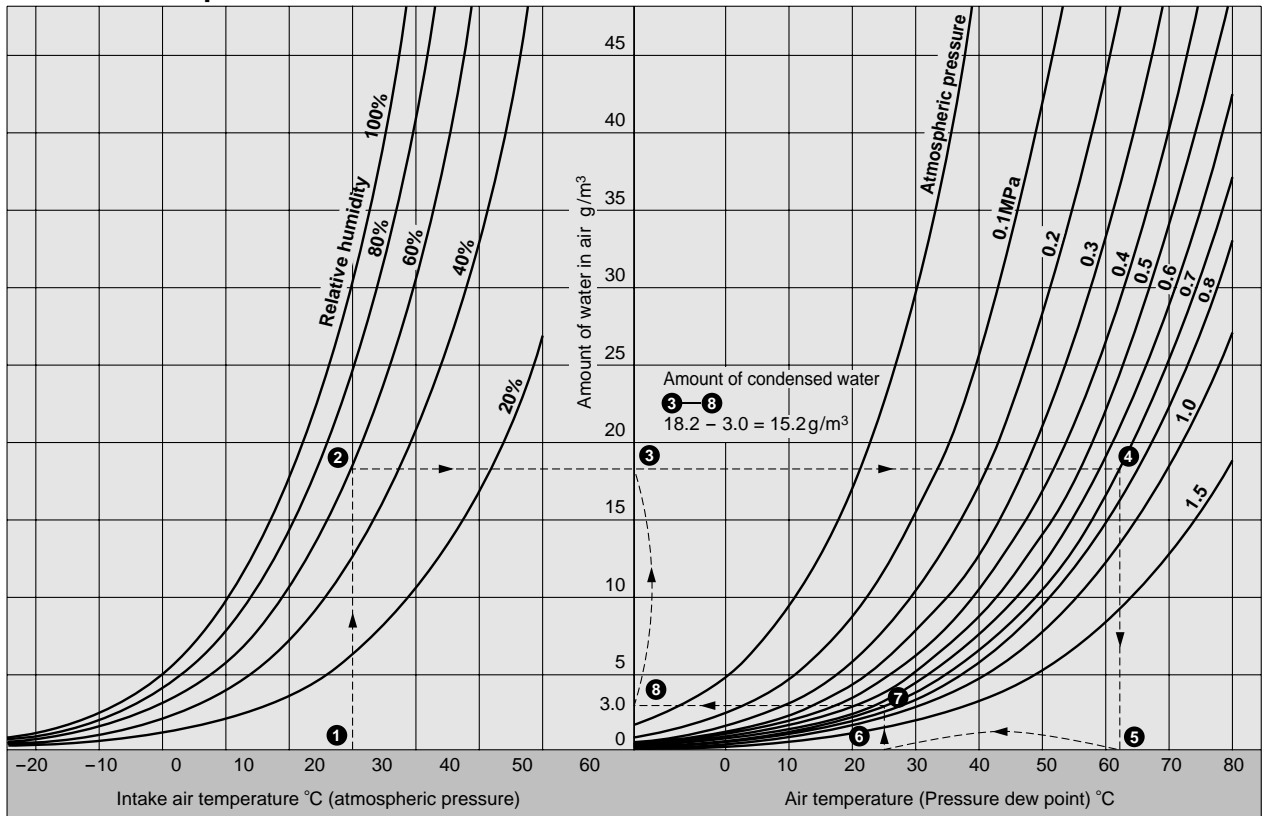

[Example] If air at 30°C and 60% humidity is pressurized to 0.7MPa, the dew point of the air will be 62°C. (1→2→3→4→5) If this is cooled to 25°C, the amount of condensed water generated will be 15.2g/m³. (6→7→8→3) Therefore, with an air flow rate of 3m³/min (22kW equivalent compressor), the amount of condensed water per unit of time is 15.2 x 3 x 60 = 2736g/h.

Dew point conversion chart

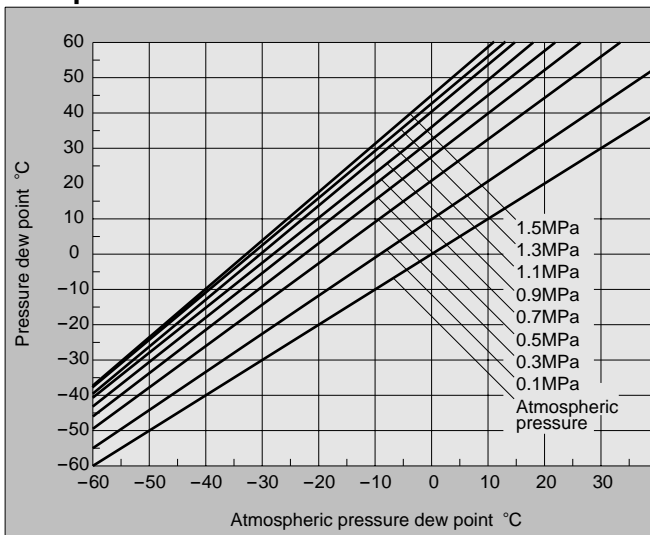



Series IDUS/IDFS

Safety Instructions

These safety instructions are intended to prevent a hazardous situation and/or equipment damage. These instructions indicate the level of potential hazard by a label of "**Caution**", "**Warning**" or "**Danger**". To ensure safety, be sure to observe ISO 4414 Note 1), JIS B 8370 Note 2) and other safety practices.

⚠ Caution : Operator error could result in injury or equipment damage.

⚠ Warning : Operator error could result in serious injury or loss of life.

⚠ Danger : In extreme conditions, there is a possible result of serious injury or loss of life.

Note 1) ISO 4414: Pneumatic fluid power – Recommendations for the application of equipment to transmission and control systems

Note 2) JIS B 8370: General Rules for Pneumatic Equipment

⚠ Warning

1. The compatibility of pneumatic equipment is the responsibility of the person who designs the pneumatic system or decides its specifications.

Since the products specified here are used in various operating conditions, their compatibility for the specific pneumatic system must be based on specifications or after analysis and/or tests to meet your specific requirements. The expected performance and safety assurance will be the responsibility of the person who has determined the compatibility of the system. This person should continuously review the suitability of all items specified. Referring to the latest catalogue information with a view to giving due consideration to any possibility of equipment failure when configuring a system.

2. Only trained personnel should operate pneumatically operated machinery and equipment.

Compressed air can be dangerous if handled incorrectly. Assembly, handling or repair of pneumatic systems should be performed by trained and experienced operators.

3. Do not service machinery/equipment or attempt to remove components until safety is confirmed.

1. Inspection and maintenance of machinery/equipment should only be performed after confirmation of safe locked-out control positions.
2. When equipment is to be removed, first confirm the safety process as mentioned above.
3. Before machinery/equipment is restarted, first confirm that safety measures are implemented, and proceed with caution.

4. Contact SMC if the product is to be used in any of the following conditions:

1. Conditions and environments beyond the given specifications, or if product is used outdoors.
2. Installation on equipment in conjunction with atomic energy, railway, air navigation, vehicles, medical equipment, food and beverages, recreation equipment, emergency stop circuits, press applications, or safety equipment.
3. An application which has the possibility of having negative effects on people, property, or animals, requiring special safety analysis.



Series IDUS/IDFS

Air Preparation Equipment Precautions 1

Be sure to read before handling.

Precautions on Design

Employ a safe design so that the following type of unexpected conditions will not occur.

⚠ Warning

1. Design so that high temperature compressed air does not flow to pneumatic equipment.

In case of cooling equipment failure (stoppage of cooling water in water cooled type after cooler, stoppage of fan motor in air cooled type after cooler, etc.) on the air supply side, high temperature compressed air can flow downstream and cause damage or malfunction of downstream equipment.

2. Use a design that allows for stoppage of the compressed air supply.

Compressed air flow may be stopped by freezing of a refrigerated air dryer or malfunction of the switching valve (heatless dryer).

⚠ Caution

1. Use a design that prevents reverse pressure and back flow.

Reverse pressure and back flow can cause equipment damage or malfunction, etc.

Give attention to safety measures, including handling procedures.

Selection

⚠ Warning

1. When selecting equipment, first adequately confirm the purpose for which it will be used, the required specifications and the operating conditions (pressure, flow rate, temperature, environment), etc. Then select equipment from the latest catalogs without exceeding the specification ranges. Contact SMC in advance regarding any questions.

2. Do not use for breathing apparatus for divers, respiration, respiration, medical treatment or for blowing of medicine or food products which will enter human body.

This cleaning equipment is exclusively for use with industrial compressed air, and should not be used for other applications. If other application is unavoidable, give attention to safety measures and contact SMC in advance.

3. This product cannot be used on vehicles or vessels.

This product cannot be used on vehicles, vessels or other transportation devices, because vibration will cause damage. If this type of use is unavoidable, contact SMC in advance.

Selection

⚠ Caution

1. Do not allow flow greater than the rated flow rate.

If the flow exceeds the rated flow rate even momentarily, this can cause drainage and oil to be sprayed downstream or cause damage, etc.

2. The product cannot be used with low pressure air (blowers).

Operating below the minimum operating pressure can cause reduced performance and malfunction. If this type of use is unavoidable, contact SMC in advance.

Mounting

⚠ Caution

1. Confirm the mounting orientation.

Since the mounting orientation is different for each piece of equipment, this should be confirmed either in this catalog or in the instruction manual. Mounting in a tilted orientation can cause faulty drainage discharge, auto drain malfunction and damage in some types of equipment.

2. Ensure sufficient maintenance space.

When installing and mounting, be sure to allow the space required for maintenance and inspections. Confirm the necessary maintenance space in the instruction manual for each piece of equipment.

Piping

⚠ Caution

1. Preparation before piping

Before piping is connected, it should be thoroughly blown out with air (flushing) or washed to remove chips, cutting oil and other debris from inside the pipe.

2. Wrapping of pipe tape

When screwing together pipes and fittings, etc., be certain that chips from the pipe threads and sealing material do not get inside the piping.

Furthermore, when pipe tape is used, leave 1.5 to 2 thread ridges exposed at the end of the threads.

3. Implement measures to prevent drainage from collecting inside piping.

Drains should be installed in the lower sections of piping that rises, or piping should be designed with a slight taper provided along the direction of flow so that drainage will not accumulate.

4. Confirm IN and OUT ports.

When piping is being installed, take care to prevent incorrect connection of the water and air sides, or the IN and OUT ports.



Series IDUS/IDFS

Air Preparation Equipment Precautions 2

Be sure to read before handling.

Air Supply

Warning

1. Do not use with fluids other than compressed air.

Cleaning equipment is designed exclusively for use with compressed air. Contact SMC in advance if a fluid other than compressed air is to be used.

2. Do not use compressed air which contains chemicals, organic solvents or corrosive gases.

Do not use compressed air containing chemicals, organic solvents, salt or corrosive gases, as this can cause damage and/or malfunction, etc.

3. Use within the operating pressure range.

The operating pressure range is determined by the equipment being used. Operation beyond this range can cause damage, failure or malfunction.

Operating Environment

Warning

1. Do not use in the following environments, as this can cause failure.

1. Locations with an atmosphere of corrosive gases, organic solvents or chemical solutions, or where there may be contact with these.
2. Locations where there is contact with sea spray, water or steam.
3. Locations which receive direct sunlight. (Sunlight should be blocked to prevent deterioration of resin from ultra violet rays, and over heating, etc.)
4. Locations near heat sources with poor ventilation. (Heat sources should be blocked off, because radiated heat may cause damage due to softening of materials.)
5. Locations with impacts or vibration. (Check the specifications for each series.)
6. Locations with high moisture and dust. (Contact SMC in advance.)

2. Adhere to the fluid and ambient temperature ranges.

The fluid and ambient temperatures are determined by the equipment being used. Operation outside of the prescribed range can cause damage, failure or malfunction, etc.

Maintenance

Warning

1. If an abnormality occurs, stop the compressed air.

If abnormalities such as smoke, unusual odor or unusual noise occur, stop the inflow of compressed air, as this may indicate a fire.

2. When performing inspections, set the compressed air pressure at zero.

When the compressed air side is to be disassembled for auto drain inspection, separator element replacement or film module replacement, etc., confirm that the pressure is at zero before proceeding.

Caution

1. Do not place heavy objects on the unit or use it as a step.

The equipment may be deformed or damaged, and if balance is lost, falling may cause injury.

2. Discharge drainage regularly.

Accumulation of drainage in equipment, piping or other areas can cause malfunction of the equipment or unexpected trouble due to splash over into the downstream side, etc. Therefore, the amount of drainage and the operation of auto drains should be checked every day.



Series IDUS/IDFS Specific Product Precautions 1 Air Preparation Equipment Precautions

Refer to pages 12 through 14 for safety instructions and cleaning equipment precautions.

Installation Location

⚠ Caution

- Avoid locations where the air dryer will be in direct contact with wind and rain. (Places where relative humidity is more than 85%)
- Avoid exposure to direct sunlight.
- Avoid dusty or corrosive environments.

If it is used in the above environments, select option C (with anti-corrosive treatment).

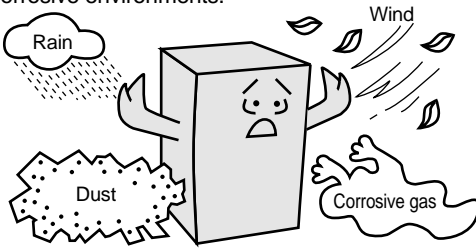

- Avoid places with poor ventilation and high temperature.

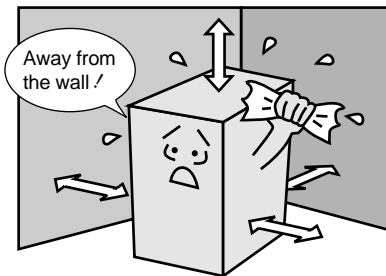

- Allow ample space around the air dryer.

- Avoid locations subjected to vibrations.
- Avoid locations where drainage can freeze.

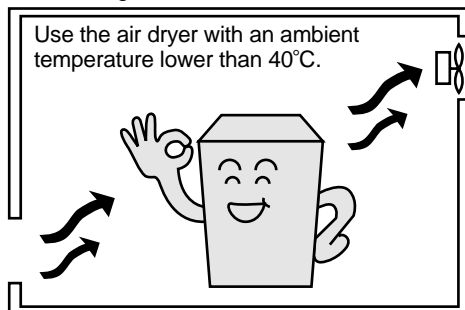

- Avoid installation on moving objects like trucks, ships, and so forth.

Drain Tube

⚠ Caution

- A polyurethane tube of 10mm outer diameter is provided as the drain tube for IDFS6E to 11E and IDUS3E to 6E. Use this tube to discharge drainage.
- Do not use the drain tube in an upward direction. Do not bend or crush the drain tube. (Operation of auto drain will stop and water will flow out through the air outlet.)

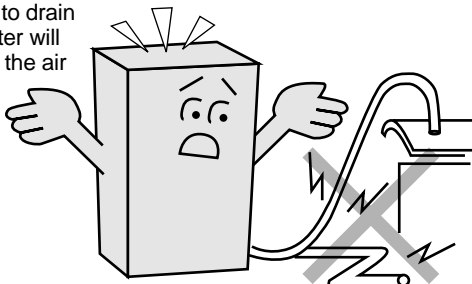

Power Supply

⚠ Caution

- Connect the power supply to the terminal block.
- Install a suitable circuit breaker applicable to each model.
- * Use a circuit breaker having a sensitivity current of 30mA or less and a rated current of 5A.

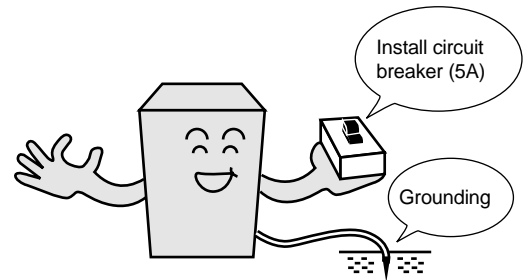

Air Piping

⚠ Caution

- Be careful to avoid errors in connecting the air piping to the compressed air inlet (IN) and outlet (OUT).
- Install bypass piping which it is needed for maintenance.

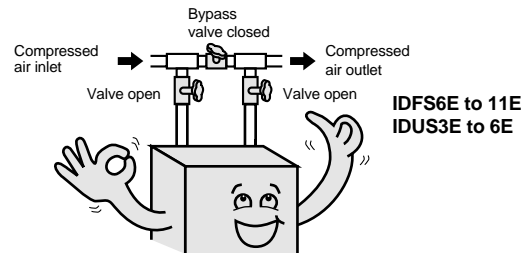

- When installing air piping at the air inlet/outlet of air dryer, the IN/OUT port's fitting of air dryer must be held firmly in place with a wrench.
- Variation of operating conditions may cause condensate to form on the surface of the outlet piping. Roll thermal insulation around piping to prevent condensate from forming.
- Vibration caused by the compressor should not be transmitted through air piping to the air dryer.
- Do not allow the weight of piping to be applied directly to the air dryer.



Series IDUS/IDFS Specific Product Precautions 2 Air Preparation Equipment Precautions

Refer to pages 12 through 14 for safety instructions and cleaning equipment precautions.

Protection Circuit

⚠ Caution

When the air dryer is operated under the following conditions, the protection circuit is activated, the light goes off and operation stops.

- When compressed air temperature is too high
- When compressed air flow rate is too high
- When ambient temperature is too high (40°C or higher)
- When power supply is beyond rated voltage by $\pm 10\%$
- When ventilation port is obstructed by a wall or clogged with dust

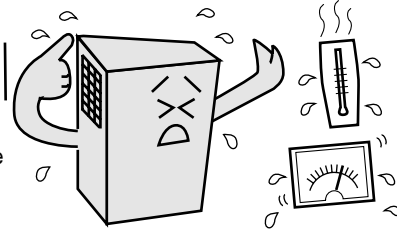

Time Delay for Restarting

⚠ Caution

Allow at least three minutes before restarting the dryer. If the air dryer is restarted within three minutes after being stopped, the protection circuit will be activated, the operating light goes off and the dryer will not be activated.

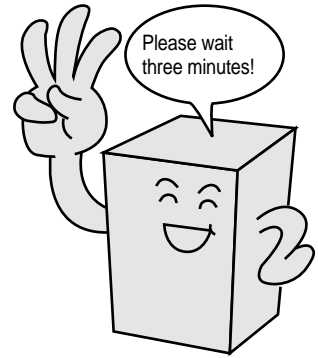

Compressor Air Delivery

⚠ Caution

Strainer, attached as air dryer's accessories, must be installed to the inlet to prevent the foreign particles from flowing into air dryer, which leads to the choking air dryer.

Use an air compressor of 100 /min or greater air delivery.

Since the auto drain is designed in such a way that the valve remains open unless the air pressure rises to 0.15MPa or higher, air will blow out from the drain discharge port when the air compressor starts up until the pressure increases. Therefore, if an air compressor has a low air delivery, the pressure may not be sufficient.

Auto Drain

⚠ Caution

The auto drain may not function properly, depending on the quality of compressed air. Check its operation once a day.

Cleaning of Ventilation Area

⚠ Caution

Remove dust from the ventilation area once a month using a vacuum cleaner or an air blow nozzle.

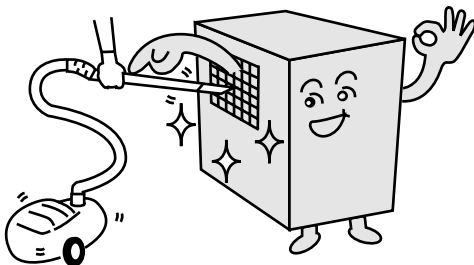



SMC'S GLOBAL MANUFACTURING, DISTRIBUTION AND SERVICE NETWORK

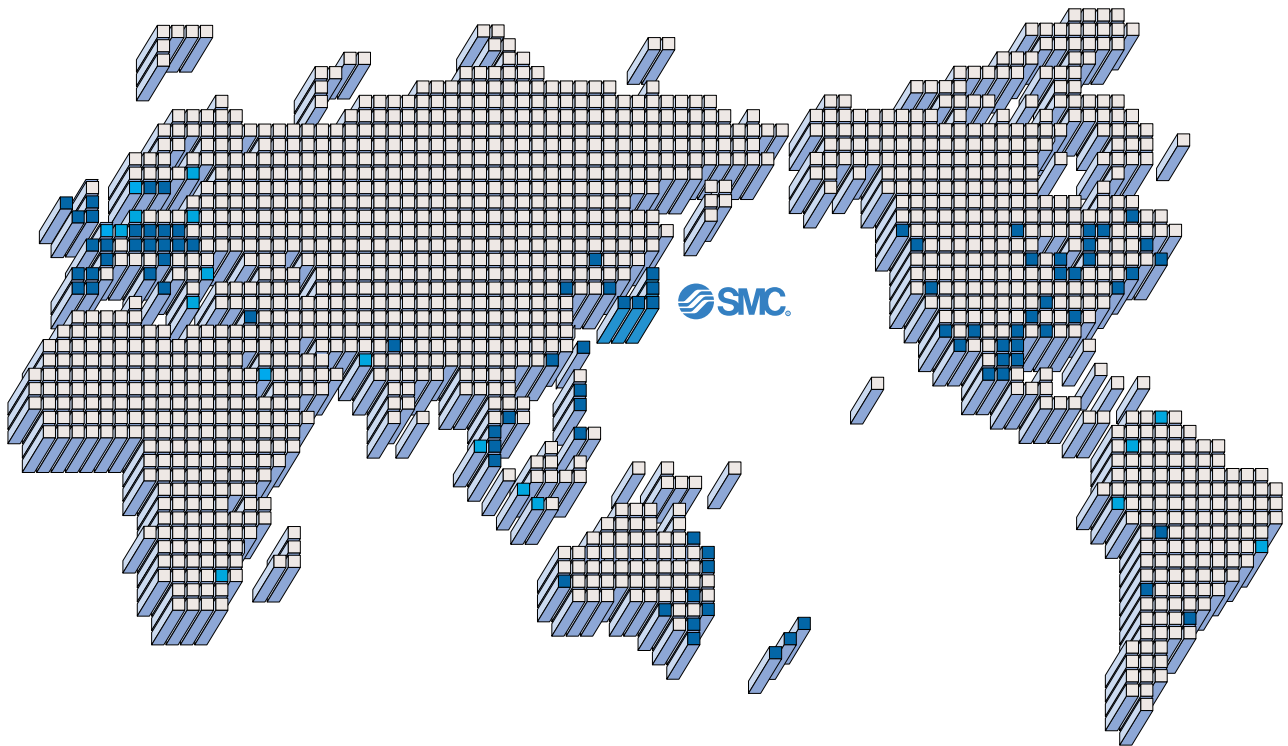

EUROPE

AUSTRIA

SMC Pneumatik GmbH

CZECH

SMC Industrial Automation CZ s.r.o.

DENMARK

SMC Pneumatik A/S

FINLAND

SMC Pneumatics Finland OY

FRANCE

SMC Pneumatique SA

GERMANY

SMC Pneumatik GmbH

HUNGARY

SMC Hungary Ipari Automatizálási Kft.

IRELAND

SMC Pneumatics (Ireland) Ltd.

ITALY

SMC Italia S.p.A.

LATVIA

SMC Pneumatics Latvia SIA

NETHERLANDS

SMC Pnuematics BV.

NORWAY

SMC Pneumatics Norway A/S

POLAND

SMC Industrial Automation Polska Sp.z.o.o.

ROMANIA

SMC Romania s.r.l.

RUSSIA

SMC Pneumatik LLC.

EUROPE

SLOVAKIA

SMC Priemyselná Automatizácia, s.r.o.

SLOVENIA

SMC Industrijska Avtomatika d.o.o.

SPAIN/PORTUGAL

SMC España, S.A.

SWEDEN

SMC Pneumatics Sweden AB

SWITZERLAND

SMC Pneumatik AG.

UK

SMC Pneumatics (U.K.) Ltd.

ASIA

CHINA

SMC (China) Co., Ltd.

HONG KONG

SMC Pneumatics (Hong Kong) Ltd.

INDIA

SMC Pneumatics (India) Pvt. Ltd.

MALAYSIA

SMC Pneumatics (S.E.A.) Sdn. Bhd.

PHILIPPINES

SMC Pneumatics (Philippines), Inc.

SINGAPORE

SMC Pneumatics (S.E.A.) Pte. Ltd.

SOUTH KOREA

SMC Pneumatics Korea Co., Ltd.

TAIWAN

SMC Pneumatics (Taiwan) Co., Ltd.

ASIA

THAILAND

SMC Thailand Ltd.

NORTH AMERICA

CANADA

SMC Pneumatics (Canada) Ltd.

MEXICO

SMC Corporation (Mexico) S.A. de C.V.

USA

SMC Corporation of America

SOUTH AMERICA

ARGENTINA

SMC Argentina S.A.

BOLIVIA

SMC Pneumatics Bolivia S.R.L.

BRAZIL

SMC Pneumaticos Do Brazil Ltda.

CHILE

SMC Pneumatics (Chile) S.A.

VENEZUELA

SMC Neumatica Venezuela S.A.

OCEANIA

AUSTRALIA

SMC Pneumatics (Australia) Pty. Ltd.

NEW ZEALAND

SMC Pneumatics (N.Z.) Ltd.

SMC Corporation

1-16-4 Shimbashi, Minato-ku, Tokyo 105-8659, JAPAN

Tel: 03-3502-2740 Fax: 03-3508-2480

URL <http://www.smcworld.com>

© 2002 SMC Corporation All Rights Reserved

1st printing May, 2002 D-DAD P-80 (YG)

This catalog is printed on recycled paper with concern for the global environment.

Specifications are subject to change without prior notice and any obligation on the part of the manufacturer.

Printed in Japan.