



Low torque Metal seal type Rotary joint

Long Life

0.1 to 1 billion rotations

* Under SMC's life test conditions.

Low rotational torque

0.003 to 0.20 N·m or less

Allowable RPM

600 to 3000 min⁻¹ (r.p.m)

Operating temperature

-10 to 80°C

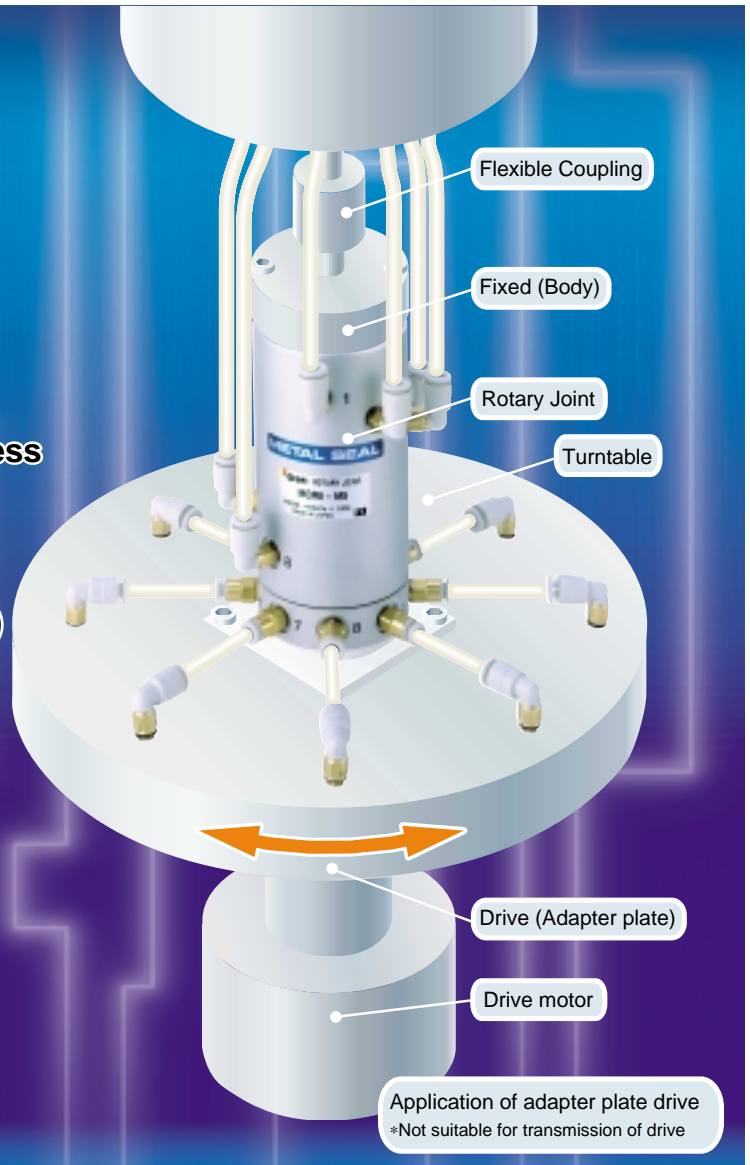

Series MQR

Low torque Metal seal type Rotary joint *Series MQR*



Rotational torque unaffected by supply pressure and temperature fluctuations

Use of metal seals prevents the spool from sticking to the rotating surface even after a long period of non-operation.

Operating pressure **-100kPa to 1MPa**

Piping ports are aligned in a spiral line for easy piping

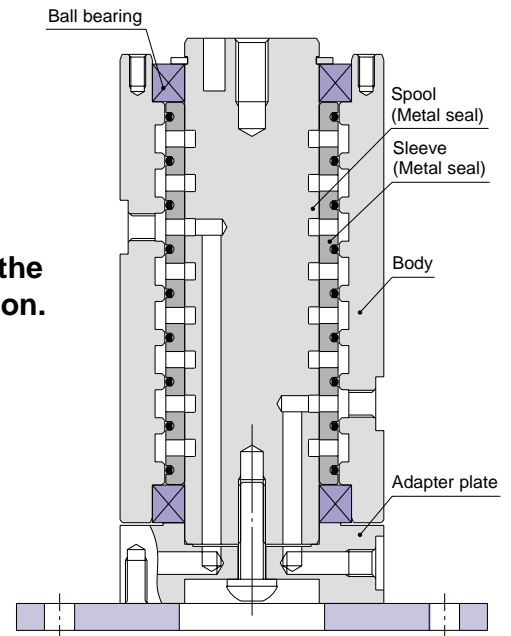

Applications

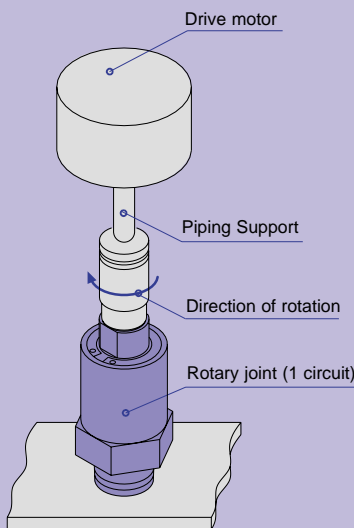

Example of 1 circuit

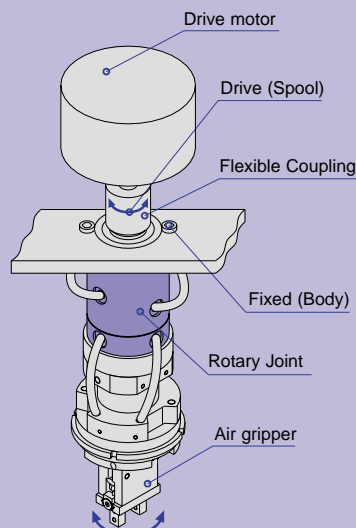

Example of spool drive

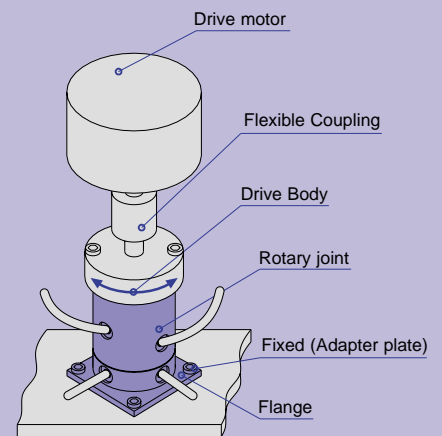

Example of body drive

Made to Order

- Operating temperature – 40 to 100°C
- 16 or more circuits

Features



Low torque Metal seal type Rotary joint

Series MQR

1 circuit, 2 circuits, 4 circuits, 8 circuits, 12 circuits

How to Order

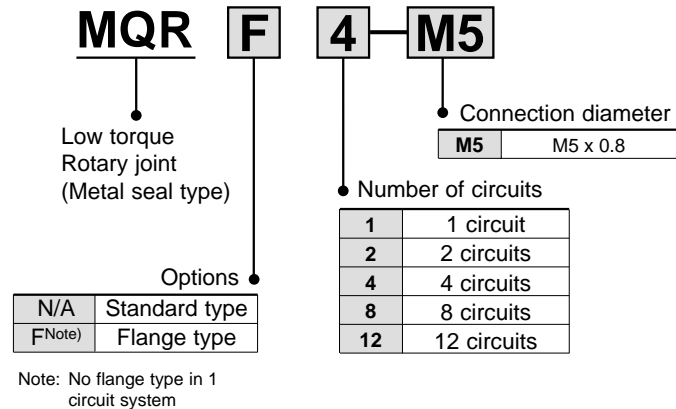

Options / Mounting bracket

| Number of circuits | Flange part number |
|--------------------|--------------------|
| 2 circuits | MQR2-F |
| 4 circuits | MQR4-F |
| 8 circuits | MQR8-F |
| 12 circuits | MQR12-F |



Specifications

| Model | MQR1-M5 | MQR2-M5 | MQR4-M5 | MQR8-M5 | MQR12-M5 |
|---|--|---------------------------------|---------------------------------|--------------------------------|--------------------------------|
| Number of circuits | 1 | 2 | 4 | 8 | 12 |
| Operating fluid | Air / Inert gas | | | | |
| Seal structure | Metal seal | | | | |
| Guide structure | Bearing supported at both ends | | | | |
| Port size | Bearing supported | | | | |
| | Male R1/8 | M5 x 0.8 | | | |
| | Female M5 x 0.8 | | | | |
| Flow rate characteristics | C[dm ³ /(s·bar)] | | b | | Cv |
| | 0.50 | | 0.40 | | 0.17 |
| Lubrication | Not required | | | | |
| Min. operating pressure | -100kPa | | | | |
| Max. operating pressure | 1.0MPa | | | | |
| Ambient temperature and operating fluid temperature ^{Note 1)} | -10 to 80°C | | | | |
| Allowable torque ^{Note 2)} | 0.003 N·m or less | 0.03 N·m or less | 0.05 N·m or less | 0.10 N·m or less | 0.20 N·m or less |
| Allowable rotation speed | 3000 min ⁻¹ (r.p.m.) ^{Note 3)} | 2000 min ⁻¹ (r.p.m.) | 1500 min ⁻¹ (r.p.m.) | 900 min ⁻¹ (r.p.m.) | 600 min ⁻¹ (r.p.m.) |
| Allowable radial load (allowable coupling axis reaction) ^{Note 4)} | 1N | 15N | 30N | 40N | 50N |
| Weight | 0.025kg | 0.16kg | 0.39kg | 0.76kg | 1.26kg |

Note 1) The temperature 80°C includes temperature rise during rotation.

Note 2) The rotational torque does not change with the supply pressure or with non-use (remains within allowable torque), but it does change with the rotational speed. (Refer to page 2).

Note 3) If using at a speed above 600 min⁻¹ (r.p.m.), ensure rotation is in the direction in which the joint is fastened.

Note 4) Rubber / resin couplings are recommended due to their excellent absorption of off center, shocks, and vibrations.

Construction

MQR1-M5

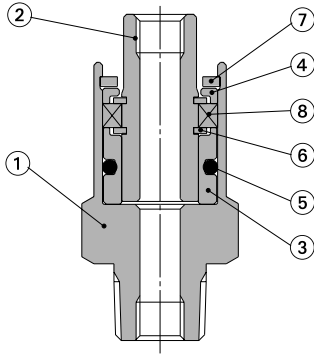

Components / (MQR1 - M5, 1 circuit)

| No. | Name | Material | Remarks |
|-----|----------------|-------------------------|---------|
| 1 | Body | Stainless steel | |
| 2 | Spool | Special stainless steel | |
| 3 | Sleeve | Special stainless steel | |
| 4 | Plate | Aluminium | |
| 5 | O-ring | H-NBR | |
| 6 | Retaining ring | Carbon steel | |
| 7 | Retaining ring | Carbon steel | |
| 8 | Radial bearing | | |

MQR2 to 12-M5

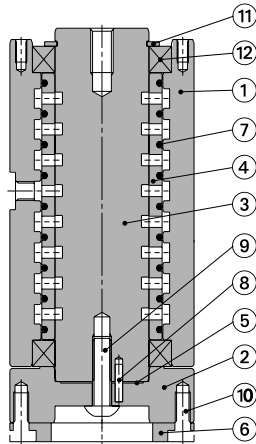

Components / (MQR2 to 12 - M5, 2 to 12 circuits)

| No. | Name | Material | Remarks |
|-----|----------------|-------------------------|------------------------|
| 1 | Body | Aluminum | |
| 2 | Adapter plate | Aluminum | |
| 3 | Spool | Special stainless steel | |
| 4 | Sleeve | Special stainless steel | |
| 5 | Gasket | H-NBR | |
| 6 | Flange | Aluminum | |
| 7 | O-ring | H-NBR | |
| 8 | Spring pin | Carbon steel | |
| 9 | Bolt | Carbon steel | Not in 2 circuit model |
| 10 | Bolt | Carbon steel | |
| 11 | Retaining ring | Carbon steel | |
| 12 | Radial bearing | — | |

Allowable leakage according to differential pressure

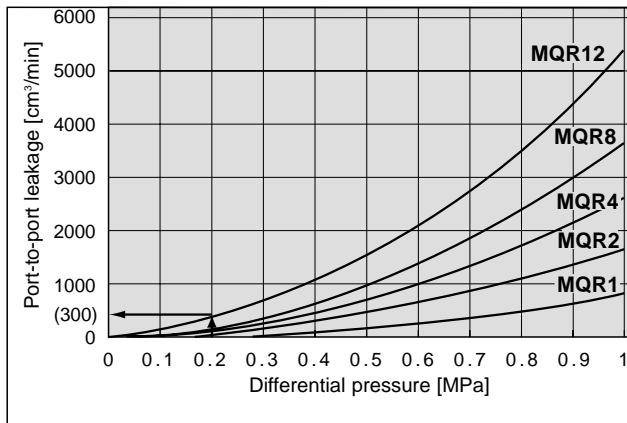

e.g.: If adjacent ports are connected to positive vacuum pressure of -0.1 MPa and 0.1 MPa in MQR12, then differential pressure is 0.2 MPa, and leakage is 300 (cm³/min).

Temperature rise with rotation speed

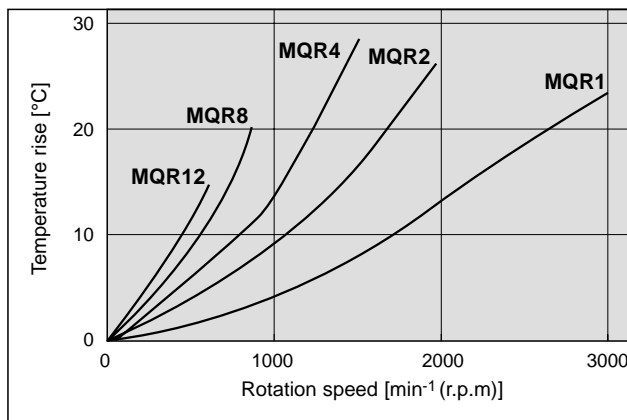

Change in rotational torque with rotation speed

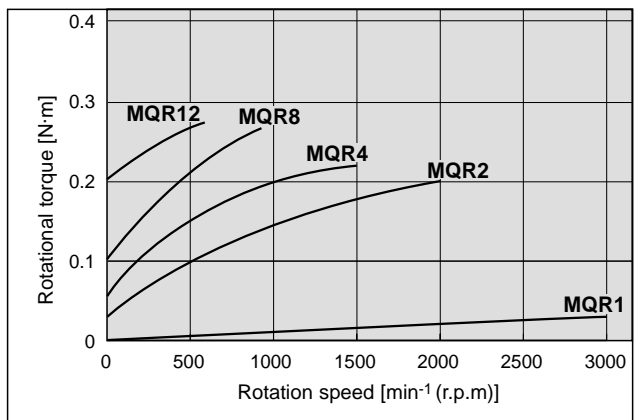

Note 1: Value when no pressure applied. Temperature rise is reduced by supply of air.

Series MQR

Dimensions/Standard Type, Flange Type

* symbol indicates flange dimensions

MQR1-M5

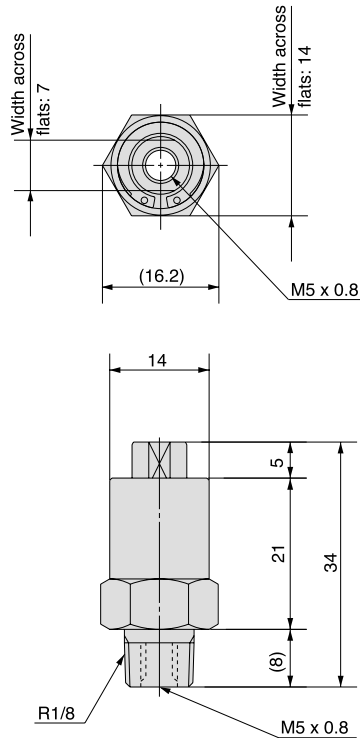

MQR2-M5

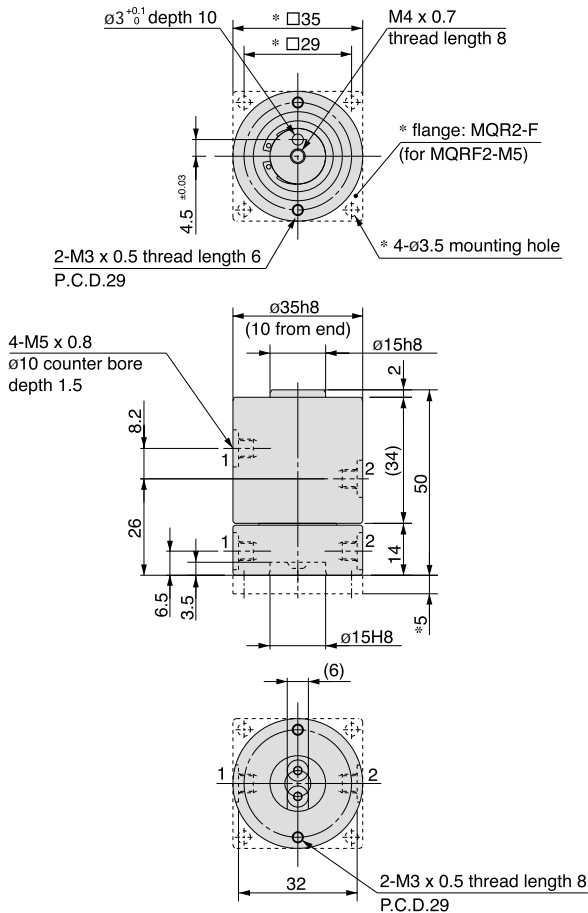

MQR4-M5

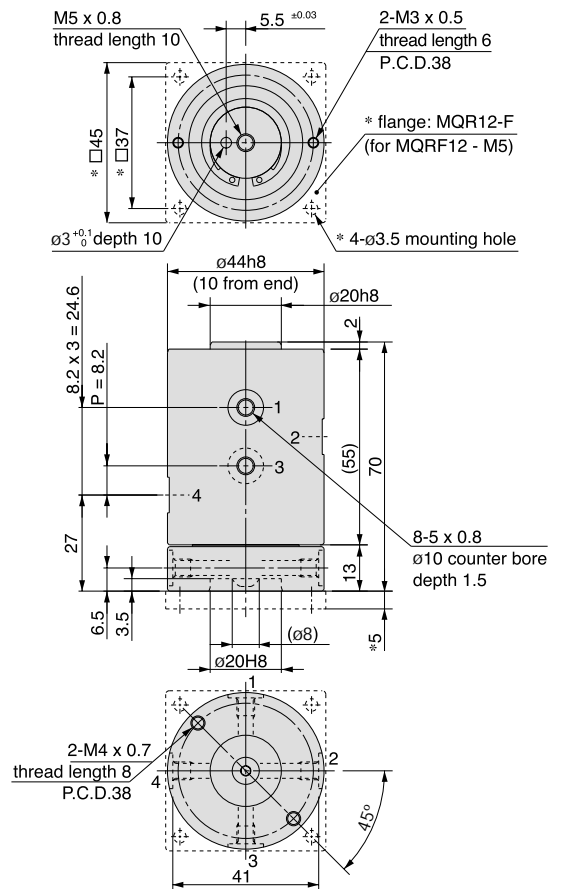

Dimensions/Standard Type, Flange Type

* symbol indicates flange dimensions

MQR8-M5

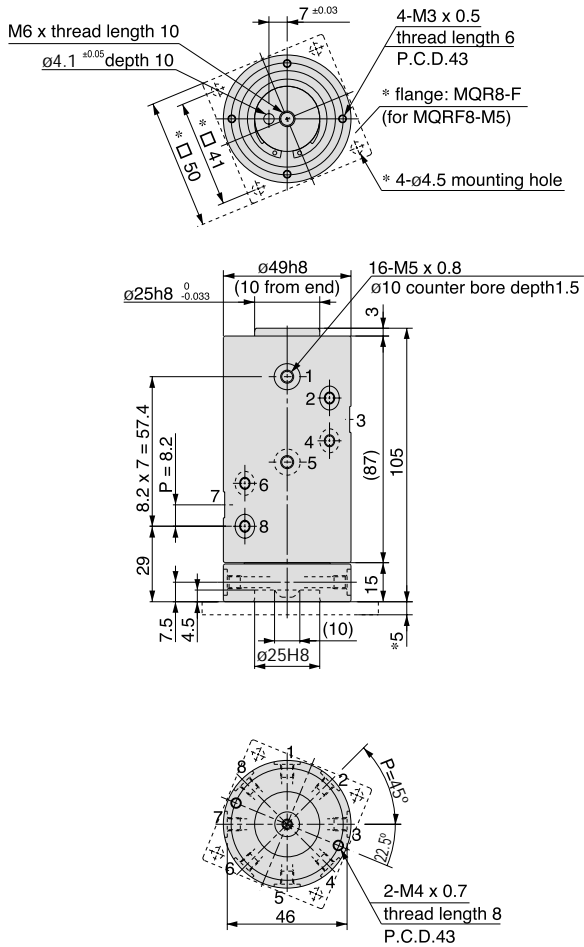

MQR12-M5

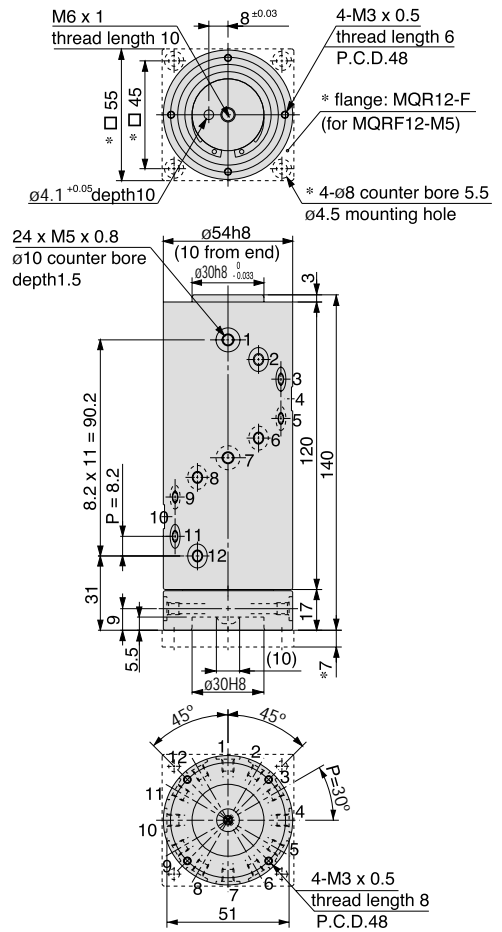

Mounting Brackets/Flanges

MQR2-F

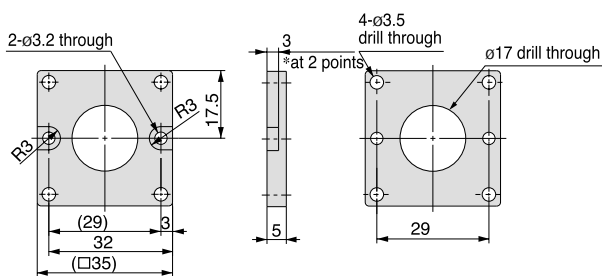

MQR4-F

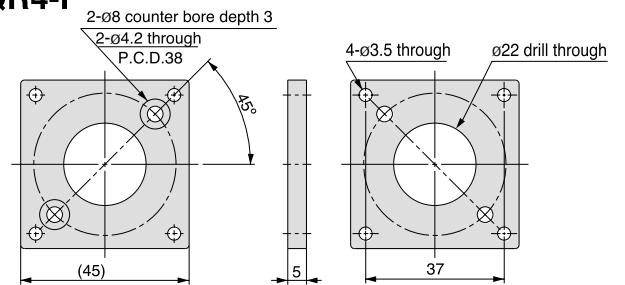

MQR8-F

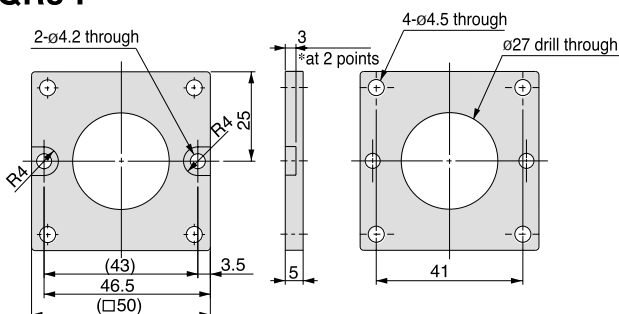

MQR12-F

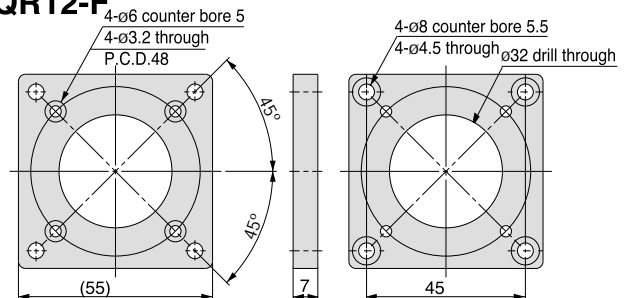





Series MQR

Safety Instructions

These safety instructions are intended to prevent a hazardous situation and/or equipment damage. These instructions indicate the level of potential hazard by a label of “**Caution**”, “**Warning**” or “**Danger**”. To ensure safety, be sure to observe ISO 4414 ^{Note 1)}, JIS B8370 ^{Note 2)} and other safety practices.

-  **Caution** : Operator error could result in injury or equipment damage.
-  **Warning**: Operator error could result in serious injury or loss of life.
-  **Danger** : In extreme conditions, there is a possible result of serious injury or loss of life.

Note 1) ISO 4414: Pneumatic fluid power – Recommendations for the application of equipment to transmission and control systems

Note 2) JIS B 8370 : General Rules for Pneumatic Equipment

Warning

1. The compatibility of pneumatic equipment is the responsibility of the person who designs the pneumatic system or decides its specifications.

Since the products specified here are used in various operating conditions, analysis and/or tests should be carried out before determining their compatibility for a specific pneumatic system. The expected performance and safety assurance will be the responsibility of the person who has determined the compatibility of the system. This person should continuously review the suitability of all items specified. Referring to the latest catalog information with a view to giving due consideration to any possibility of equipment failure when configuring a system.

2. Only trained personnel should operate pneumatically operated machinery and equipment.

Compressed air can be dangerous if an operator is unfamiliar with it. Assembly, handling or repair of pneumatic systems should be performed by trained and experienced operators.

3. Do not service machinery/equipment or attempt to remove components until safety is confirmed.

1. Inspection and maintenance of machinery/equipment should only be performed after confirmation of safe locked-out control positions.
2. When equipment is to be removed, confirm the aforementioned safety step. Cut the supply pressure to the equipment and exhaust all residual compressed air in the system.
3. Before restarting machinery/equipment, ensure that anti-lurching measures have been taken.

4. Contact SMC if the product is to be used in any of the following conditions:

1. Conditions and environments beyond the given specifications, or if the product is used outdoors.
2. Installation on equipment in conjunction with atomic energy, railway, air navigation, vehicles, medical equipment, food and beverages, recreational equipment, emergency stop circuits, press applications, or safety equipment.
3. An application which has the possibility of having negative effects on people, property, or animals, requiring special safety analysis.



Series MQR Rotary Joint/Precautions 1

Be sure to read before handling.

Design

Warning

- 1. A protective cover is recommended to minimize the risk of human injury**
If a moving part poses a risk of human injury and/or damage to machinery/equipment, then a structure which prevents direct contact with that part should be adopted.
- 2. Securely tighten all stationary parts and connected parts so that they will not become loose**
Secure fastening is particularly important when the rotary joint has a high operating frequency.
- 3. Provide safety devices in drive circuit**
Collisions, or foreign material introduced by the air source, may cause scuffing or burning of rotating parts, which in turn leads to increased rotational torque. Install safety devices in the drive circuit accordingly.
- 4. Pressure**
Air leakage occurs in these products. They cannot be used for pressure holding in pressure vessels, etc.
- 5. Do not use in an emergency shutdown air circuit**
These products are not designed for use in a safety circuit performing emergency shutdown. Other reliable safety protection means should be adopted for such systems.
- 6. Ensure room for maintenance**
Leave sufficient space for maintenance work.
- 7. Releasing residual pressure**
Provide a residual pressure release function in order to carry out maintenance work.
- 8. Using vacuum supply**
When using a vacuum air supply, install a suction filter, or equivalent, to prevent infiltration of dirt and foreign material via the absorption pad or exhaust port.

Selection

Warning

- 1. Confirm the specifications**
The products advertised in this catalog are designed according to use in industrial compressed air systems. If the products are used in conditions where pressure, temperature, etc., are out of specification, damage and/or malfunction may be caused. Do not use in these conditions. (Refer to specifications.)
- 2. Do not use for power transmission**
These products are not designed to be used as bearings for transmitting power from a drive source, such as a motor. Such use may lead to rotation faults, or damage.

Mounting

Warning

- 1. Prevent impacts on shaft when drive source is started**
If excessive offset load is applied to the product, it may cause malfunction, breakdown, or personal injury or damage to machinery and equipment. Use a flexible coupling as illustrated below, to avoid direct radial load or axial load on the shaft. A rubber/resin coupling is recommended, due to its excellent absorption of off center, shocks, and vibrations. Please consult the coupling manufacturer to discuss the detailed operating conditions.
- 2. Do not make additions to this product**
Any additions made to this product will weaken it and may cause product failure, leading to human injury and/or damage to machinery/equipment.
- 3. Allow freedom of movement when securing the shaft**
If you do not allow some freedom of movement when fixing the shaft, then any eccentricity will cause abnormal wear, leading to malfunction, breakdown, and possible human injury and/or damage to machinery/equipment.

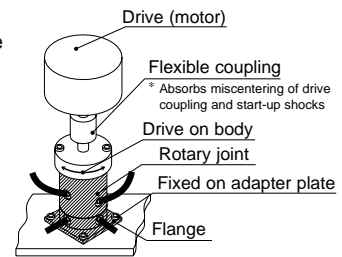

Caution

- 1. Confirm the model and size before installation. Check that there are no scratches, impact marks, cracks, or the like, on the product.**
- 2. When connecting tubes, take account of variations in pressure according to tube length.**
- 3. Do not wipe model designation on nameplate with organic solvents, etc.**
This will cause designation to disappear.
- 4. Do not knock rotary shaft when main unit is fixed, or knock main unit when rotary shaft is fixed.**
This may bend the rotary shaft and cause damage to the bearings. The rotary shaft should be fixed when attaching a load, etc. to it.

Piping

Caution

- 1. Preparation before piping**
Before piping is connected, it should be thoroughly blown out with air (flushed), to remove chips, cutting oil and other debris from inside the piping.
- 2. Wrapping of sealant tape**
When screwing together pipes and fittings, etc., be certain that chips from the pipe threads and sealant material do not get inside the piping. Also, when sealant tape is used, leave approximately 2 thread ridges exposed at the end of the threads.

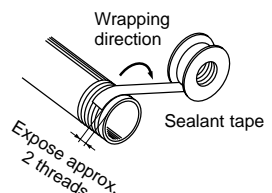



Series MQR Rotary Joint/Precautions (2)

Be sure to read before handling.

Piping

Caution

3. Screw tightening and tightening torque

Use the tightening torques in the table below, when screwing a fitting onto a piping port. Particular attention is required in the case of MQR1 (1 circuit), as this joint supports the piping.

Tightening torque for piping

| Connecting threads | Suitable tightening torque |
|--------------------|----------------------------|
| M5 | 1.5 to 2 N·m |
| Rc 1/8 | 7 to 9 N·m |

Comments

Fastening M5 thread fittings

Tighten manually, and then tighten a further quarter-turn using the fastening tool. If using miniature fittings, tighten manually, and then tighten a further quarter-turn using the fastening tool. If there are two gaskets, such as a universal elbow or universal tee, the final tightening should be doubled to a half-turn.

Note: Over-tightening of fittings may cause fracturing of the thread sections or deformation of the gaskets, leading to air leaks. If the fittings are under-tightened, the loosening of thread and air leaks may occur.

Lubrication

Caution

1. Lubrication

1. Due to the initial lubricant provided, the product can be used without lubrication.
2. Do not lubricate if using the product at low torque. Lubrication may cause an increase in the rotational torque, due to the viscosity and surface tension of the oil.
3. In the event that lubrication is applied, use turbine oil class 1 (without additives) ISO VG32.
Please consult us regarding use of turbine oil class 2 (with additives) ISO VG32.

Air Supply

Warning

1. Use clean air.

Do not use compressed air containing chemicals, synthetic oils containing organic solvents, salts, or corrosive gases, etc., as these can cause damage or malfunction.

Air Supply

Caution

1. Use the product within the range of specifications for fluid and ambient temperature

Take measures to prevent freezing when used at 5°C or less, since moisture in circuits can freeze, causing malfunction.

2. Install air filters

Install air filters near valves on their upstream side. The filtration degree should be 5 micron or less. Furthermore, when using at low friction, it is also recommended to use clean air (atmospheric pressure dew point temperature of -10°C) and install mist separator series AM (filtration degree 0.3 micron or less) or series AM + AMD (filtration degree 0.01 micron or less).

3. Install an after-cooler, air dryer or water separator, etc.

Air containing excessive drainage can cause malfunction of valves and other pneumatic equipment. To prevent this, install an after-cooler, air dryer or water separator, etc.

Refer to the "Best Pneumatics vol.4" catalog for details on compressed air quality.

Operating Environment

Warning

1. Do not use in environments where there is a danger of corrosion.

Refer to the construction drawings regarding rotary joint materials.

2. Do not use in dusty locations or where water, oil, etc., will splash on the equipment.

Maintenance

Warning

1. Perform maintenance according to the procedures indicated in the instruction manual.

If handled improperly, malfunction and damage of machinery or equipment may occur.

2. During maintenance, do not perform any disassembly or assembly whilst the air supply is connected.

Caution

1. Drain flushing

Remove condensate from air filters at regular intervals.

Disassembly

Caution

1. The component parts of these products are manufactured to precision tolerances, and therefore cannot be disassembled.



Series MQR

Product-specific Precautions (1)

Be sure to read before handling.

Also consult the safety information and precautions relating to the use of rotary joints on pages 9 and 10.

Operation

⚠ Caution

1. The metal seal structure means that port-to-port leaking occurs. Therefore, please note the following points when using different pressures at neighbouring ports.

When using different pressures at normal pressure

Use relieving type regulators.

Leaks between ports are to be exhausted via the relief port of the regulator on the lower pressure side.

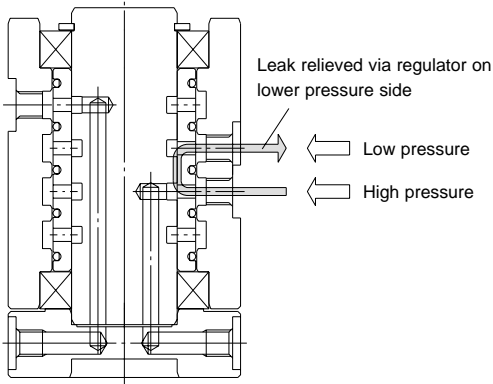

When combination of vacuum and normal pressures

When using a compact vacuum ejector (suction flow rate approx. 10 L/min), the vacuum pressure drop is several kPa or so, depending on the supply source characteristics and the piping conditions. For more details, please refer to the flow rate characteristics graph provided in the vacuum pump catalogue, instruction manual, etc.

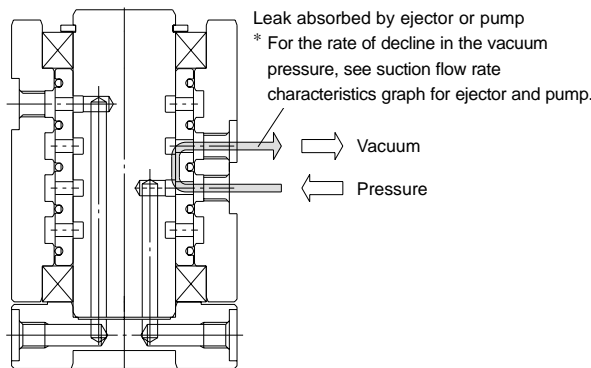

Using different pressures in vacuum

As neither the ejector nor the vacuum pump has a relief function, pressure interference may occur. Install an atmospheric release port (blanking port) or normal pressure circuit between the pressure ports having different vacuum pressures.

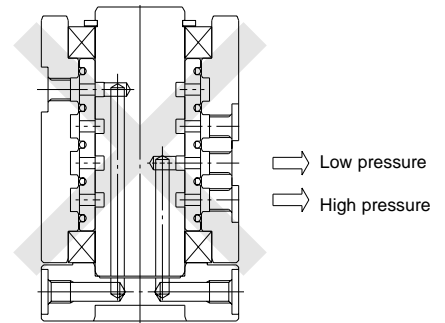

* If neighbouring ports are used at different vacuum pressures, the vacuum pressure on the lower vacuum side will increase and hence it cannot be used.

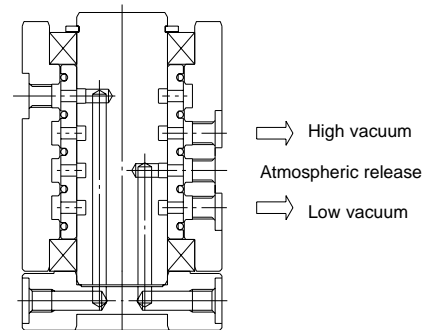

Using atmospheric release port

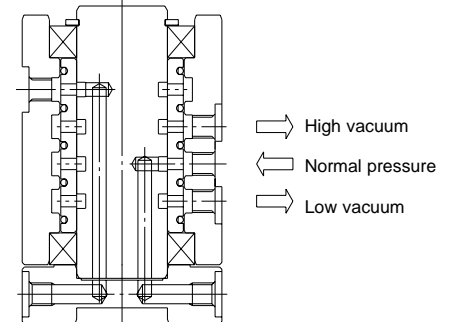

Using normal pressure port

* If using two or more ports at different vacuum pressures, an atmospheric release port or a normal air supply should be provided between the ports.



SMC'S GLOBAL MANUFACTURING, DISTRIBUTION AND SERVICE NETWORK

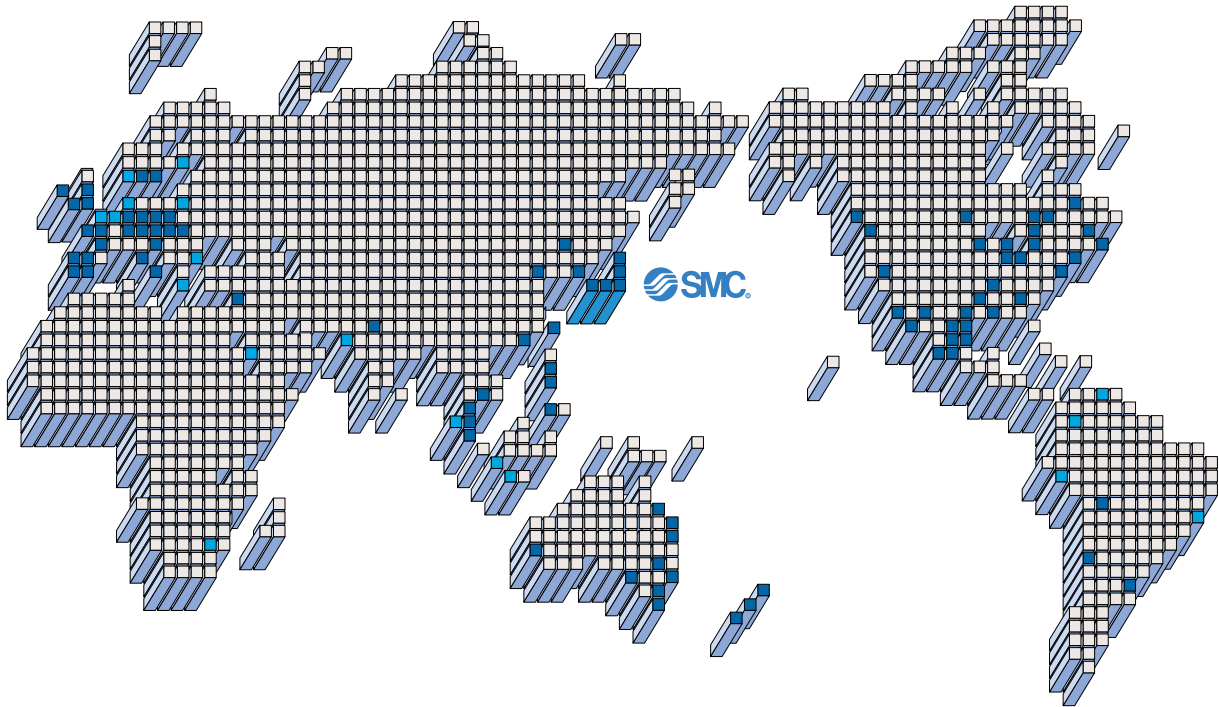

EUROPE

AUSTRIA

SMC Pneumatik GmbH

CZECH

SMC Industrial Automation CZ s.r.o.

DENMARK

SMC Pneumatik A/S

FINLAND

SMC Pneumatics Finland OY

FRANCE

SMC Pneumatique SA

GERMANY

SMC Pneumatik GmbH

HUNGARY

SMC Hungary Ipari Automatizálási Kft.

IRELAND

SMC Pneumatics (Ireland) Ltd.

ITALY

SMC Italia S.p.A.

LATVIA

SMC Pneumatics Latvia SIA

NETHERLANDS

SMC Pnuematics BV.

NORWAY

SMC Pneumatics Norway A/S

POLAND

SMC Industrial Automation Polska Sp.z.o.o.

ROMANIA

SMC Romania s.r.l.

RUSSIA

SMC Pneumatik LLC.

EUROPE

SLOVAKIA

SMC Priemyselná Automatizácia, s.r.o.

SLOVENIA

SMC Industrijska Avtomatika d.o.o.

SPAIN/PORTUGAL

SMC España, S.A.

SWEDEN

SMC Pneumatics Sweden AB

SWITZERLAND

SMC Pneumatik AG.

UK

SMC Pneumatics (U.K.) Ltd.

ASIA

CHINA

SMC (China) Co., Ltd.

HONG KONG

SMC Pneumatics (Hong Kong) Ltd.

INDIA

SMC Pneumatics (India) Pvt. Ltd.

MALAYSIA

SMC Pneumatics (S.E.A.) Sdn. Bhd.

PHILIPPINES

SMC Pneumatics (Philippines), Inc.

SINGAPORE

SMC Pneumatics (S.E.A.) Pte. Ltd.

SOUTH KOREA

SMC Pneumatics Korea Co., Ltd.

TAIWAN

SMC Pneumatics (Taiwan) Co., Ltd.

ASIA

THAILAND

SMC Thailand Ltd.

NORTH AMERICA

CANADA

SMC Pneumatics (Canada) Ltd.

MEXICO

SMC Corporation (Mexico) S.A. de C.V.

USA

SMC Corporation of America

SOUTH AMERICA

ARGENTINA

SMC Argentina S.A.

BOLIVIA

SMC Pneumatics Bolivia S.R.L.

BRAZIL

SMC Pneumaticos Do Brazil Ltda.

CHILE

SMC Pneumatics (Chile) S.A.

VENEZUELA

SMC Neumatica Venezuela S.A.

OCEANIA

AUSTRALIA

SMC Pneumatics (Australia) Pty. Ltd.

NEW ZEALAND

SMC Pneumatics (N.Z.) Ltd.

SMC Corporation

1-16-4 Shimbashi, Minato-ku, Tokyo 105-8659, JAPAN

Tel: 03-3502-2740 Fax: 03-3508-2480

URL <http://www.smcworld.com>

© 2002 SMC Corporation All Rights Reserved

1st printing June, 2002 D-MITAKA P-80 (DN)

This catalog is printed on recycled paper with concern for the global environment.

Specifications are subject to change without prior notice and any obligation on the part of the manufacturer.

Printed in Japan.