

Heatless Air Dryer

Series ID

Heatless ID series is best when dry air with a low dew point is needed.

Supply dry air with a low dew point below -30°C .

Compact and lightweight without heater and electric control board.

Possible to check the outlet dew point with the indicator.

(Self-regenerative style allows for easy maintenance.)

Model

Model	ID20□	ID30□	ID40□	ID60□
Outlet air flow rate (ℓ/min (ANR))	80	155	330	780
Recycled air flow ^{Note)} (ℓ/min (ANR))	20	37	85	195
Inlet air flow rate (ℓ/min (ANR))	100	192	415	975
Port size (Nominal size B)	1/4	1/2	1/2	3/4
Weight (kg)	7	8.5	18.5	25



Note) Inlet air pressure: In the case of 0.7 MPa

Specifications

Model	ID20□	ID30□	ID40□	ID60□
Fluid	Compressed air			
Operating pressure (MPa)	0.3 to 1.0		0.3 to 0.9	
Inlet air temperature ($^{\circ}\text{C}$)	5 to 50			
Ambient temperature ($^{\circ}\text{C}$)	2 to 50			
Voltage & power consumption $\pm 10\%$	100 VAC, 200 VAC (50/60 Hz) 30 W			
Installation features	Indoor			



Note) Inlet air pressure: 0.7 MPa, Inlet air temperature: 35°C , Outlet air dew point (atmospheric pressure): -30°C

Accessory (Option)/Replacement Parts

Applicable model	ID20□	ID30□	ID40□	ID60□
Bracket	6604113	6604113	660651	660651
Mist Separator	AM150	AM250	AM250	AM350
Adsorbent set ^{Note)}	ID-200S	ID-300S	ID-400S	ID-600S
Adsorbent set (for low dew point) ^{Note)}	ID-200Z	ID-300Z	ID-400Z	ID-600Z
Indicator set	ID-DPM8			



Note) Adsorbent and adsorption tube filter for one air dryer (two adsorption tubes), set of O-rings

Option Specifications (Low dew point)

Model	ID20□	ID30□	ID40□	ID60□
Outlet atmospheric pressure dew point	-50°C ^{Note)}			



Note) When the refrigerated air dryer is installed on the inlet side. (Inlet air pressure: 0.7 MPa, Inlet air temperature: 20°C)



JIS Symbol

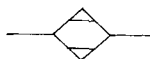

How to Order

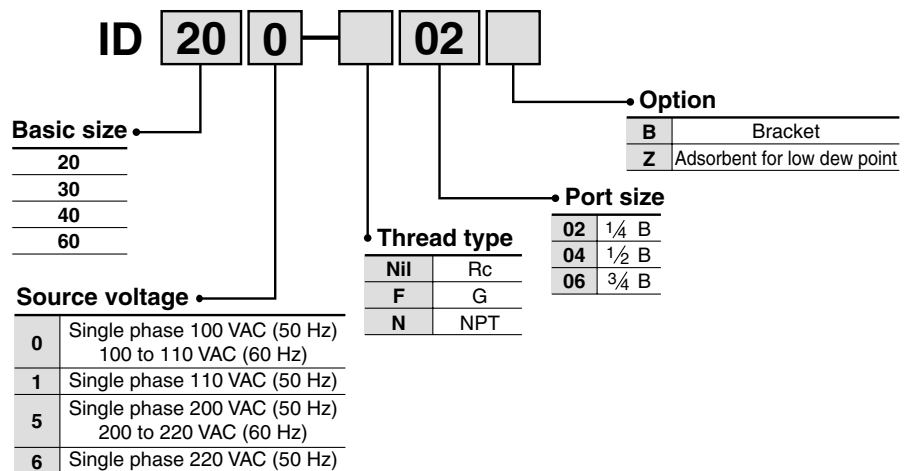

HA□

AT

ID□

AMG

AFF

AM□

Misc.

Series ID

Working Principle

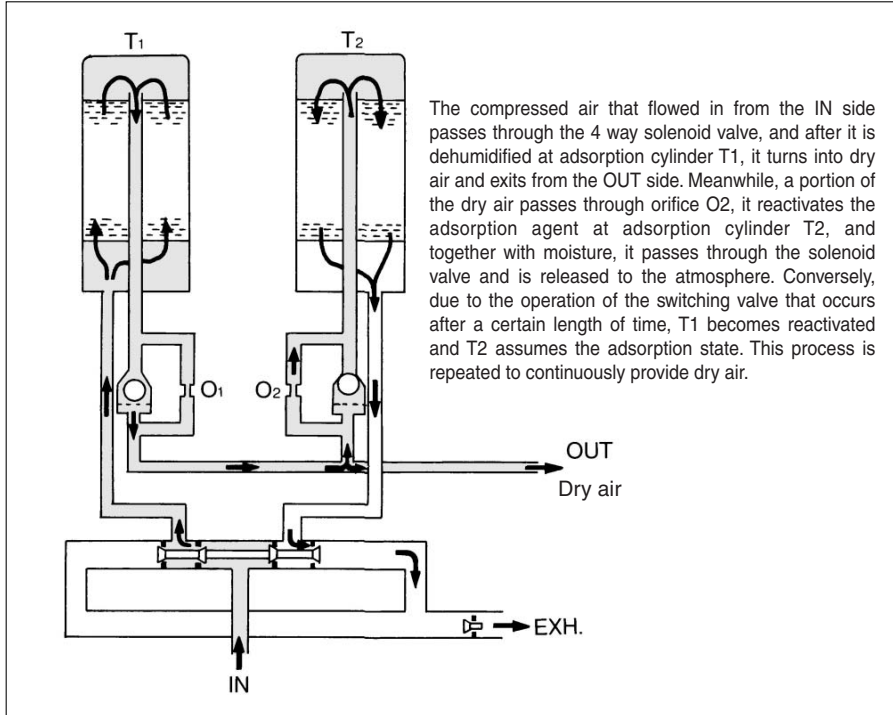

Flow Rate Inlet pressure: 0.7 MPa

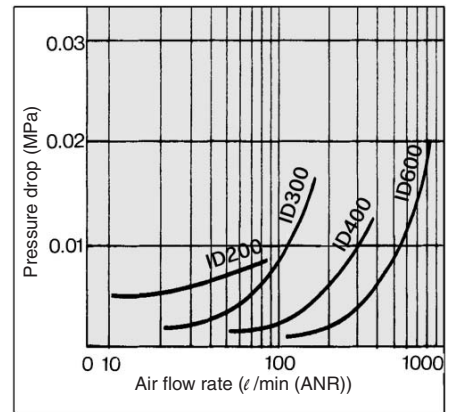

Recycled Flow Rate

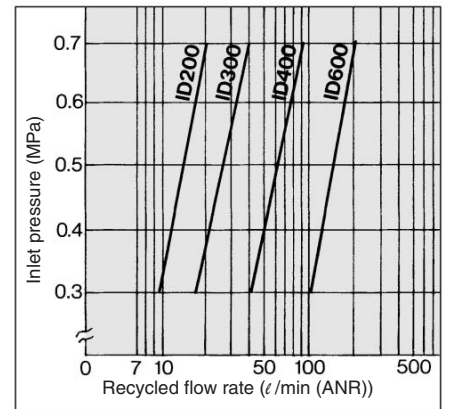

Dew Point Condition: Air flow/Rating

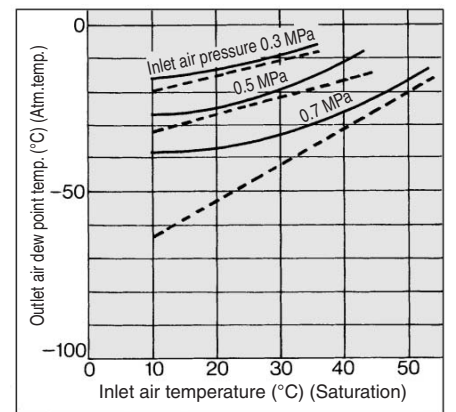

Operating System Diagram/Time Chart/Electric Circuit Diagram

Operating system diagram

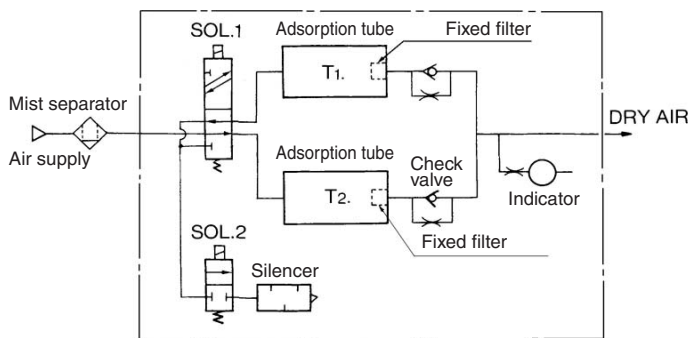

Time chart

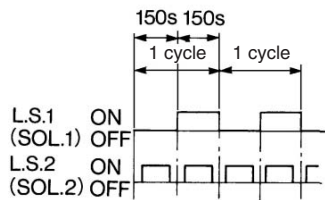

Electric circuit

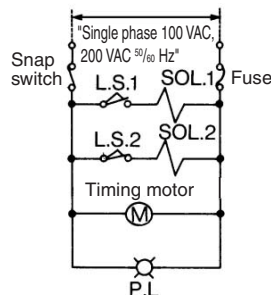

Note 1) 100 VAC: Length of cord with attachment plug 2 m
 Note 2) 200 VAC: Length with cable cord 2 m

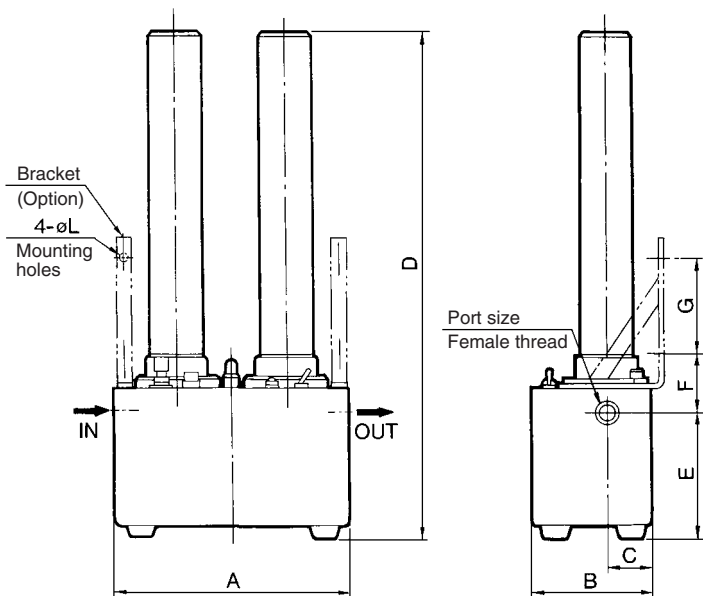
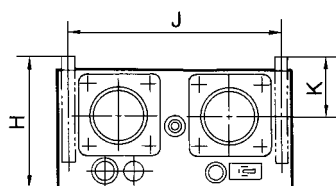
Dimensions

Model	Port size Nominal size (B)	A	B	C	D	E	Mounting dimension					
							F	G	H	J	K	øL
ID200	1/4	240	120	45	520	128.5	59.5	95	134.5	222	59.5	9
ID300	1/2	240	120	45	615	128.5	59.5	95	134.5	222	59.5	9
ID400	1/2	320	170	75	850	243.5	66.5	95	183	302	88	9
ID600	3/4	320	170	75	961	243.5	66.5	95	183	302	88	9

⚠ Precautions

Be sure to read before handling. Refer to pages 14-21-3 to 14-21-4 for Safety Instructions and Common Precautions on the products mentioned in this catalog, and refer to pages 14-14-6 to 14-14-8 for Precautions on every series.

Caution on Design**⚠ Caution**

1. Install this air dryer on a pneumatic line that provides a supply capacity that exceeds the required outlet air flow rate and reactivated air flow rate.
If the pneumatic line cannot provide the supply capacity indicated, the required outlet air flow rate and pressure cannot be obtained.
2. Make sure to install a mist separator on the inlet side.
If foreign matter such as oil mist or dust is present in the compressed

air, the capillary tissue of the adsorption agent becomes blocked. This will substantially reduce the adsorption capacity and at the same time, shorten the life of the adsorption agent.

3. Due to a pressure fluctuation that occurs during the switching of the adsorption cylinders, the small particles of the adsorption agent could splash to the outlet side.
Install a mist separator or a micro-mist separator on the outlet side according to the application.
4. When installing a regulator, install it on the outlet side of the heatless air dryer.
If it is installed on the inlet side and used when the pneumatic pressure is low, the air dryer's dehumidifying capacity cannot be put into full play. (For details, refer to the performance line graph in this section.)

Piping**⚠ Caution**

1. Make sure to provide a bypass pipe in case the flow of air cannot be stopped during maintenance, such as when replacing the adsorption agent.
2. Install the dryer horizontally.
3. Do not allow the weight of piping to lie directly on air dryer.

Operating Environment**⚠ Caution**

The air that has been used for reactivating the adsorption agent and the air that has passed through the indicator are discharged externally from the heatless air dryer. Therefore, use the dryer in an area where the discharge will not be a problem.

Operation**⚠ Caution**

Turn ON the power after the air dryer has been pressurized.
If the power is turned ON before it is pressurized (particularly when the pressure is low), the check valve will not operate properly, possibly creating an abnormally large reactivated air flow rate.

Maintenance**⚠ Caution**

1. Replace the adsorbent according to color of the indicator.

Dew point temperature (Atmospheric pressure)	Color of indicator
-30°C or less	Dark blue
-18°C	Light blue
-10°C	Light pink
-5°C	Pink

* Conditions/Inlet air pressure 0.7 MPa
Inlet air temperature 30°C

Please use the adsorbent set (refer to page 14-19-1 for "Accessory/Replacement Parts") when replacing the adsorbent.

2. Replace the element of the mist separator, installed on the inlet side, on a regular basis. (Refer to the instruction manual of the mist separator for details such as the replacement interval and procedures.)

HA AT ID AMG AFF AM Misc.