

Sine Rodless Cylinder  
**Series REA/REB**  
(Max. speed: 300mm/s) (Max. speed: 600mm/s)

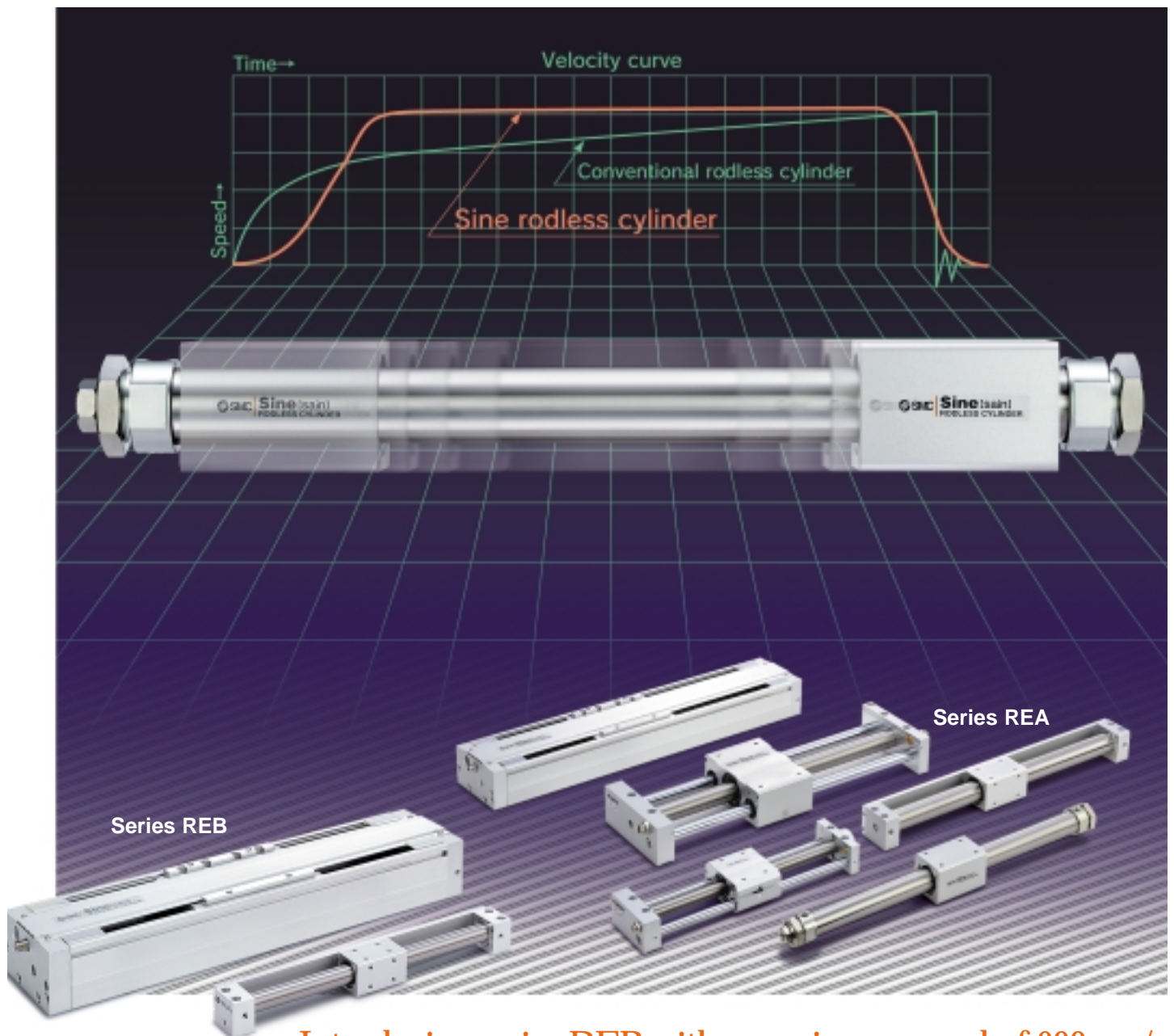

Introducing series REB with a maximum speed of 600mm/s

# Allows rapid

Semiconductor wafers  
Magnetic disks  
Ceramic products  
Glass products  
Liquid crystal substrates

# transfer of impact

## Throughput dramatically increased (Maximum speed: 600mm/s)

Series REB introduced with a maximum speed of 600mm/s. Compared with the previous type (series REA: 300mm/s), the tact time can be shortened by approximately 1/2.

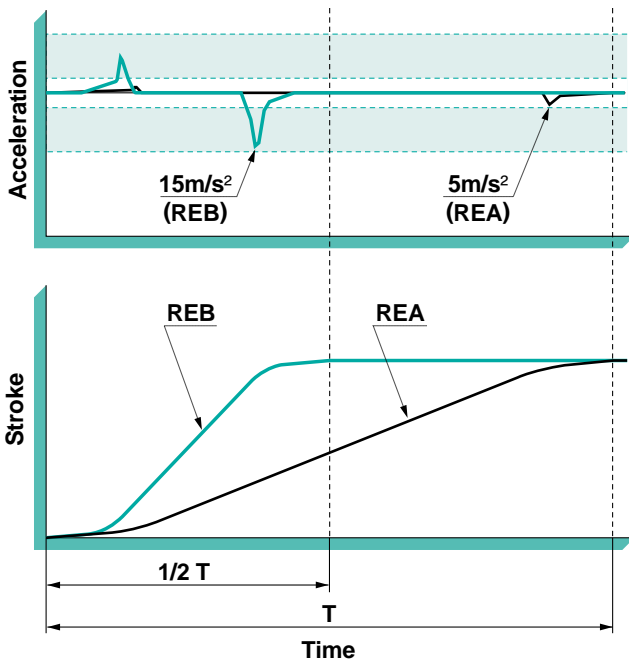

Smooth acceleration & deceleration at  $5\text{m/s}^2$

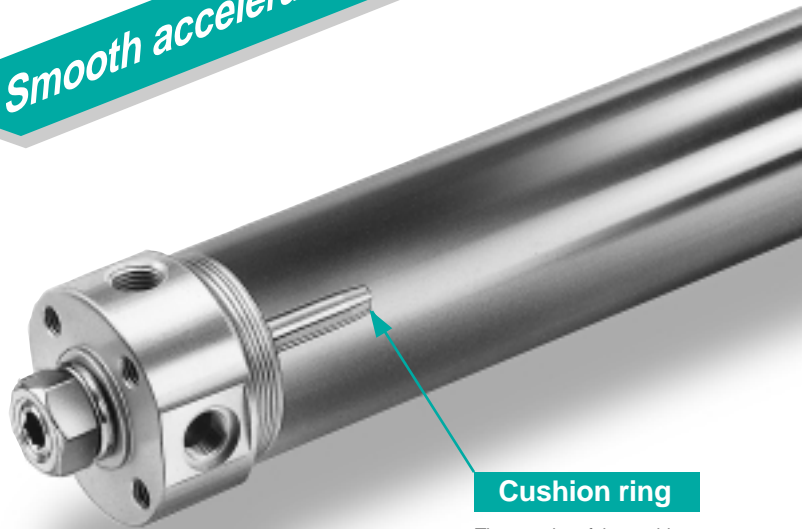

**Cushion ring**

The exterior of the cushion ring is provided with a variable throttle groove in its longitudinal direction.

## Acceleration ranges

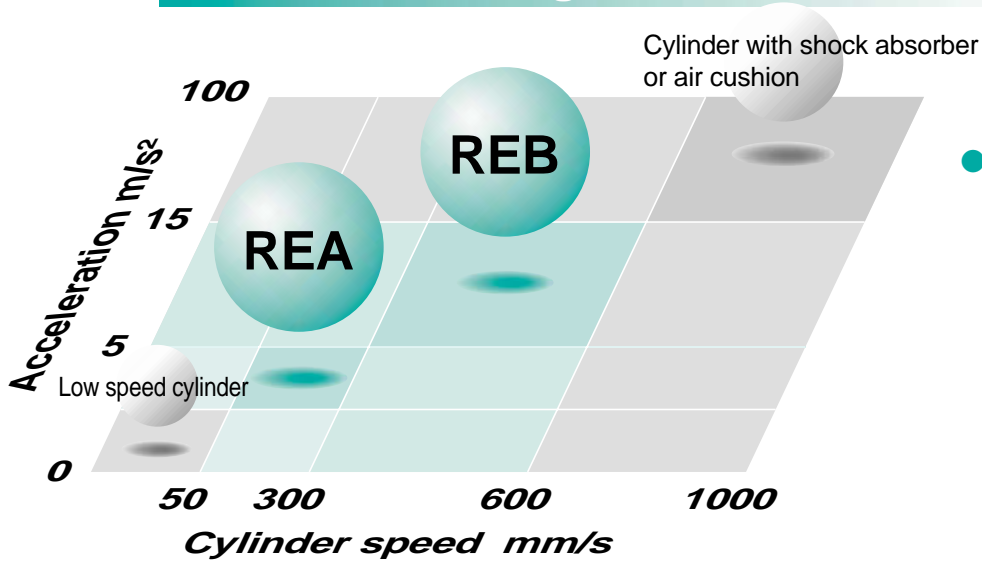





### Series variations Series REA (300mm/s)

Guide type	Base cylinder	Model
Basic type	CY1B	REA
Direct mount type	CY1R	REAR
Slider type (slide bearing)	CY1S	REAS
Slider type (ball bushing)	CY1L	REAL
High precision guide (1 axis)	CY1H	REAH
High precision guide (2 axes)	CY1HT	REAHT

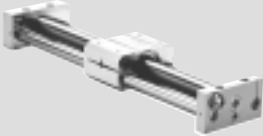

# Series REA/REAR/REBR/REAS/REAL/REAH/REBH Model Selection Criteria

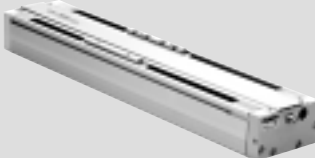
Model selection criteria	Recommended cylinder			
		Appearance	Features	
<ul style="list-style-type: none"> <li>• When many different types of guides are used</li> <li>• When a long stroke is necessary</li> </ul>	Non-integrated guide type	<p>Series <b>REA</b> Size: <math>\phi 25</math>, <math>\phi 32</math>, <math>\phi 40</math>, <math>\phi 50</math>, <math>\phi 63</math></p> 	<ul style="list-style-type: none"> <li>• Wide variations from <math>\phi 25</math> to <math>\phi 63</math></li> </ul>	<ul style="list-style-type: none"> <li>• Long strokes available.</li> </ul>
<ul style="list-style-type: none"> <li>• When many different types of guides are used</li> <li>• When auto switches are added to the basic type</li> <li>• When used without a guide for a light load</li> <li>• When space is very limited</li> </ul>		<p>Series <b>REAR</b> Size: <math>\phi 10</math>, <math>\phi 15</math>, <math>\phi 20</math>, <math>\phi 25</math>, <math>\phi 32</math>, <math>\phi 40</math></p> <p>Series <b>REBR</b> Size: <math>\phi 15</math>, <math>\phi 25</math>, <math>\phi 32</math></p> 	<ul style="list-style-type: none"> <li>• Available with a maximum speed of 300mm/s or 600mm/s.</li> </ul>	<ul style="list-style-type: none"> <li>• Cylinder can be directly mounted.</li> <li>• Auto switch capable, with no cylinder lurching.</li> <li>• Rotation can be stopped within an allowable range.</li> <li>• Compact external dimensions</li> <li>• Mounting can be performed from the top or one side.</li> </ul>
<ul style="list-style-type: none"> <li>• To ensure a permanent path</li> <li>• When used for general transfer operations</li> </ul>	Integrated guide type	<p>Series <b>REAS</b> Size: <math>\phi 10</math>, <math>\phi 15</math>, <math>\phi 20</math>, <math>\phi 25</math>, <math>\phi 32</math>, <math>\phi 40</math></p> 	<ul style="list-style-type: none"> <li>• A load can be carried directly by the integrated guide type.</li> <li>• The centralized piping type allows concentration of piping on one side plate.</li> <li>• Auto switch capable.</li> <li>• Available with a maximum speed of 300mm/s or 600mm/s. (RE□H/High precision guide type)</li> </ul>	<ul style="list-style-type: none"> <li>• Smooth operation is made possible by using special slide bearings.</li> </ul>
<ul style="list-style-type: none"> <li>• To ensure a permanent path</li> <li>• When smoother operation is required, even with an eccentric load</li> </ul>		<p>Series <b>REAL</b> Size: <math>\phi 10</math>, <math>\phi 15</math>, <math>\phi 20</math>, <math>\phi 25</math>, <math>\phi 32</math>, <math>\phi 40</math></p> 		<ul style="list-style-type: none"> <li>• Stable operation is possible, even with an eccentric load, by using ball bushings.</li> </ul>
<ul style="list-style-type: none"> <li>• To ensure a permanent path</li> <li>• When a large load, large moment or high precision are required</li> <li>• When used for pick-and-place operations, etc.</li> </ul>		<p>Series <b>REAH</b> Size: <math>\phi 10</math>, <math>\phi 15</math>, <math>\phi 20</math>, <math>\phi 25</math>, <math>\phi 32</math></p> <p>Series <b>REBH</b> Size: <math>\phi 15</math>, <math>\phi 25</math>, <math>\phi 32</math></p> 		<ul style="list-style-type: none"> <li>• The use of a linear guide facilitates a large load, large moment and high precision.</li> <li>• Mounting freedom is improved by providing T-slots on the mounting surfaces.</li> <li>• A top cover mounted over the sliding parts of the cylinder prevents scratches and damage, etc.</li> </ul>

# Series REA

## Basic Type/ø25, ø32, ø40, ø50, ø63

Max. Speed  
300  
mm/s

Basic Type  
REA

Direct Mount Type  
REAR

Slider Type/Slide Bearing  
REAS

Slider Type/Ball Bushing  
REAL

High Precision Guide Type  
REAH

Max. Speed  
600  
mm/s

Direct Mount Type  
REBR

High Precision Guide Type  
REBH

Auto Switches

Order Made

### How to Order



**Basic type** REA 25 — 300

Sine rodless cylinder (basic type)

Bore size

25	25mm
32	32mm
40	40mm
50	50mm
63	63mm

Stroke (mm)

Refer to the standard stroke table.

### Specifications

Fluid	Air
Proof pressure	1.05MPa
Maximum operating pressure	0.7MPa
Minimum operating pressure	0.18MPa
Ambient and fluid temperature	-10 to 60°C (with no freezing)
Piston speed	50 to 300mm/s
Lubrication	Non-lube
Stroke length tolerance	0 to 250st: $^{+1}_0$ , 251 to 1000st: $^{+1.4}_0$ , 1001st and up: $^{+1.8}_0$

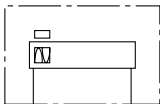

Symbol

### Standard Strokes

Bore size (mm)	Standard stroke (mm)	Maximum manufacturable stroke (mm)
25	200, 250, 300, 350, 400, 450, 500, 600, 700, 800	4000
32	200, 250, 300, 350, 400, 450, 500, 600, 700, 800	
40	200, 250, 300, 350, 400, 450, 500, 600, 700, 800, 900, 1000	5000
50	200, 250, 300, 350, 400, 450, 500, 600, 700, 800, 900, 1000	6000
63	200, 250, 300, 350, 400, 450, 500, 600, 700, 800, 900, 1000	

Note 1) Intermediate strokes can be arranged in 1mm increments.

Note 2) Strokes over 2000mm are available as order made. (Refer to -XB11 on page 88)

### Magnetic Holding Force

Bore size (mm)	25	32	40	50	63
Holding force (N)	363	588	922	1,470	2,260

### Weights

Bore size (mm)	25	32	40	50	63
Basic weight (kg)	0.71	1.34	2.15	3.4	5.7
Additional weight per 50mm stroke (kg)	0.05	0.07	0.08	0.095	0.12

Calculation example: REA32-500  
 Basic weight ..... 1.34kg  
 Additional weight ..... 0.07/50mm  
 Cylinder stroke ..... 500mm  
 }  $1.34 + 0.07 \times 500 \div 50 = 2.04\text{kg}$

## ⚠ Specific Product Precautions

Be sure to read before handling. Refer to pages 92 through 94 for safety instructions and actuator precautions.

### Mounting

#### ⚠ Caution

1. Take care to avoid nicks or other damage on the outside surface of the cylinder tube.

This can lead to damage of the scraper and wear ring, which in turn can cause malfunction.

2. Pay attention to the rotation of the external slider.

Rotation should be controlled by connecting it to another shaft (linear guide, etc.).

3. Do not operate with the magnetic coupling out of position.

In case the magnetic coupling is out of position, push the external slider back into the correct position by hand at the end of the stroke (or correct the piston slider with air pressure).

4. Be sure that both head covers are secured to the mounting surface before operating the cylinder.

Avoid operation with the external slider secured to the surface.

5. Do not apply a lateral load to the external slider.

When a load is mounted directly to the cylinder, variations in the alignment of each shaft center cannot be offset, and this results in the generation of a lateral load that can cause malfunction. The cylinder should be operated using a connection method which allows for shaft alignment variations and deflection due to the cylinder's own weight. A drawing of a recommended mounting is shown in Figure 2.

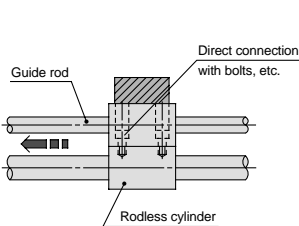

Variations in the load and cylinder shaft alignment cannot be offset and may result in a malfunction.

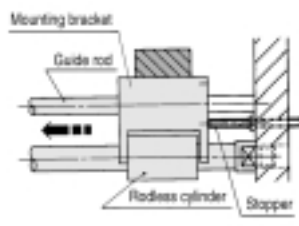

Shaft alignment variations are offset by providing clearance between the mounting bracket and cylinder. Moreover, the mounting bracket is extended above the cylinder shaft center, so that the cylinder is not subjected to moment.

Figure 1.

Incorrect mounting

Figure 2.

Recommended mounting

6. Use caution regarding the allowable load weight when operating in a vertical direction.

The allowable load weight when operating in a vertical direction (reference values on page 5 is determined by the model selection method. However, if a load greater than the allowable value is applied, the magnetic coupling may break and there is a possibility of dropping the load. When using this type of application, contact SMC regarding the operating conditions (pressure, load, speed, stroke, frequency, etc.).

### Disassembly & Maintenance

#### ⚠ Caution

1. When reattaching the head covers after disassembly, confirm that they are tightened securely.

When disassembling, hold the wrench flats of one head cover with a vise, and remove the other cover using a spanner or adjustable wrench on the wrench flats. When retightening, first coat with Loctite (No. 542 red), and retighten 3 to 5° past the original position prior to removal.

### Stroke Adjustment

#### ⚠ Caution

1. This mechanism is not intended for adjustment of the cushion effect (smooth start-up, soft stop). This mechanism is for matching of the cylinder's stroke end position to the mechanical stopper, etc., of a machine. (adjustment range from 0 to -2mm)
2. Before adjustment is performed, shut off the drive air, release any residual pressure and implement measures to prevent dropping of work pieces, etc.

### Stroke End Adjustment

(To ensure safety, implement with air shut down.)

#### ⚠ Caution

1. Loosen lock nut A.
2. Insert a wrench into the hexagon socket of the adjustment screw, and turn it to the left or right, matching the cushion ring holder (stroke end) with the position of the external stopper by moving it backward or forward.
3. After the stroke end adjustment is completed, retighten lock nut A, and apply high strength Loctite No. 262 or another comparable locking agent.

#### Adjustment screw hexagon socket

Model	Width across flats (mm)
REA25	5
REA32	5
REA40	6
REA50	8
REA63	8

#### Lock nut A fastening torque

Model	Fastening torque (N·m)
REA25	1.2
REA32	1.2
REA40	2.1
REA50	3.4
REA63	3.4

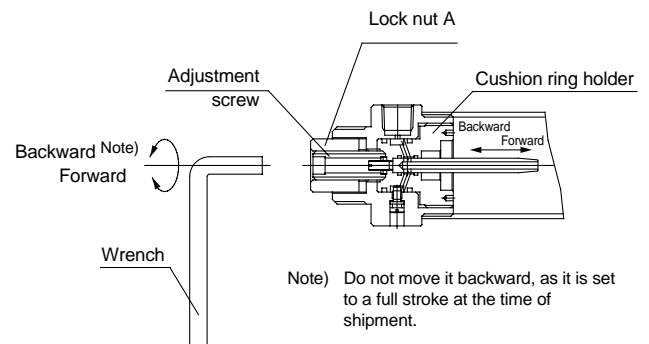

# Series REA Model Selection 1

**F<sub>n</sub>**: Allowable driving force (N)  
**P<sub>v</sub>**: Maximum operating pressure for vertical operation (MPa)  
**W<sub>Bmax</sub>**: Maximum connection fitting weight (kg)  
**W<sub>v</sub>**: Allowable load weight for vertical operation (kg)

**Operating conditions**

- **W**: Load weight (kg)
- **W<sub>B</sub>**: Connection fitting weight (kg)
- **μ**: Guide's coefficient of friction
- **L<sub>o</sub>**: Distance from cylinder shaft center to work piece point of application (cm)
- **Mode of operation** (horizontal, inclined, vertical)
- **P**: Operating pressure (MPa)
- **U**: Maximum speed (mm/s)
- **Stroke** (mm)

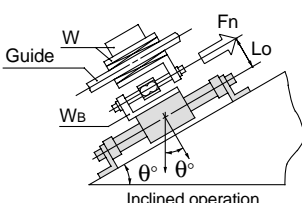
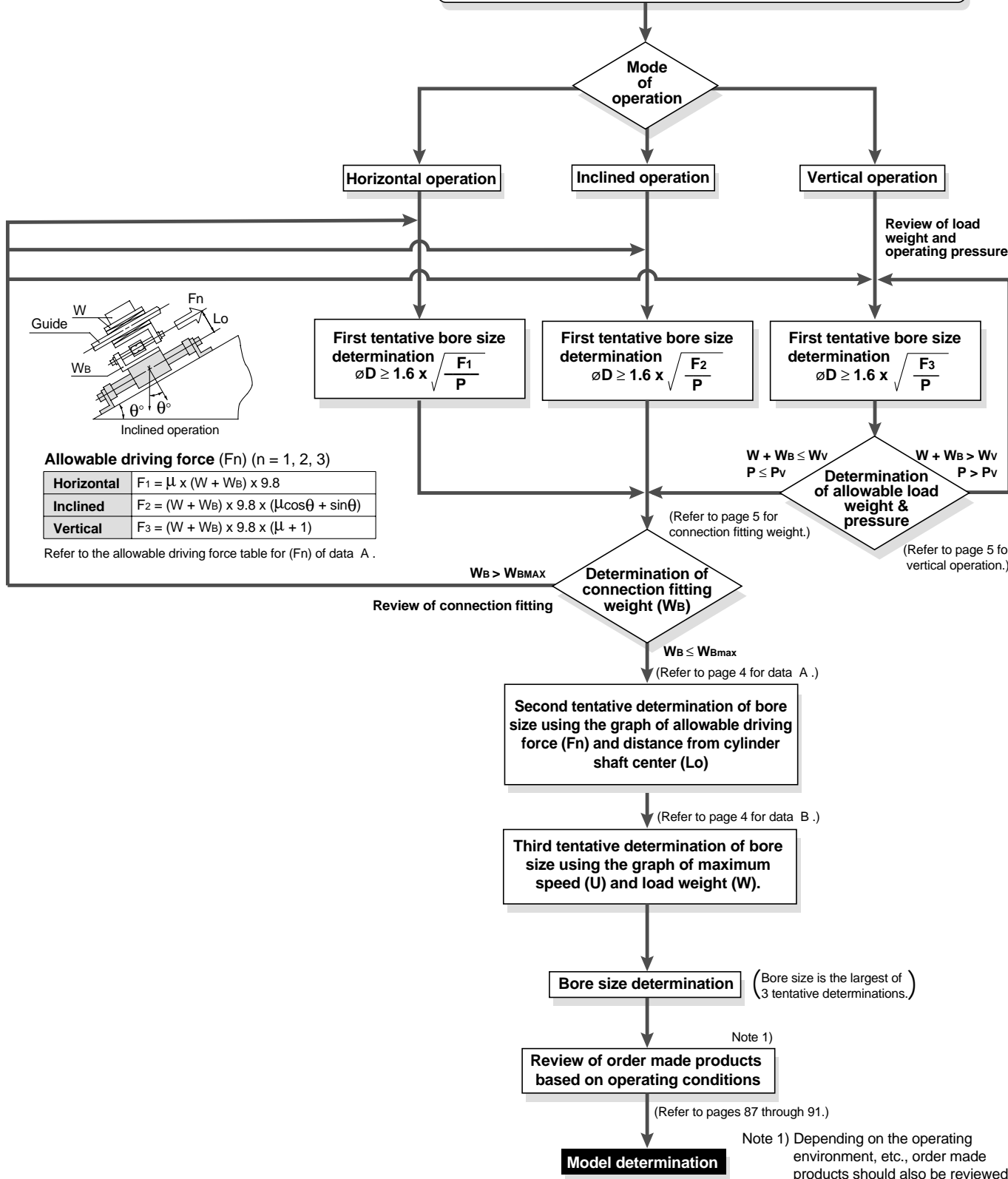

**Allowable driving force (F<sub>n</sub>) (n = 1, 2, 3)**

<b>Horizontal</b>	$F_1 = \mu \times (W + W_B) \times 9.8$
<b>Inclined</b>	$F_2 = (W + W_B) \times 9.8 \times (\mu \cos \theta + \sin \theta)$
<b>Vertical</b>	$F_3 = (W + W_B) \times 9.8 \times (\mu + 1)$

Refer to the allowable driving force table for (F<sub>n</sub>) of data A.

Max. Speed 300 mm/s

Basic Type REA

Direct Mount Type REAR

Slider Type/Slide Bearing REAS

Slider Type/Ball Bushing REAL

High Precision Guide Type REAH

Max. Speed 600 mm/s

Direct Mount Type REBR

High Precision Guide Type REBH

Auto Switches

Order Made

# Series REA Model Selection 2

## Design Parameters 1

### Selection Method

<Data A: Distance from cylinder shaft center — Allowable driving capacity>

ø25

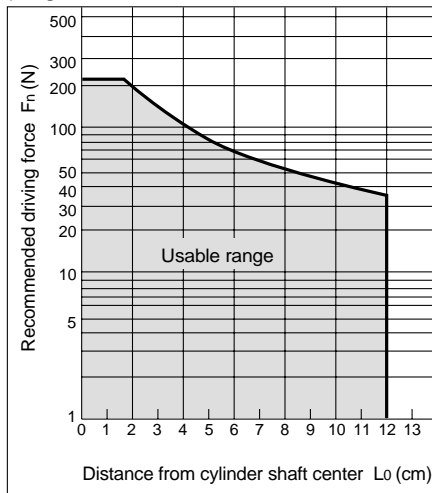

ø32

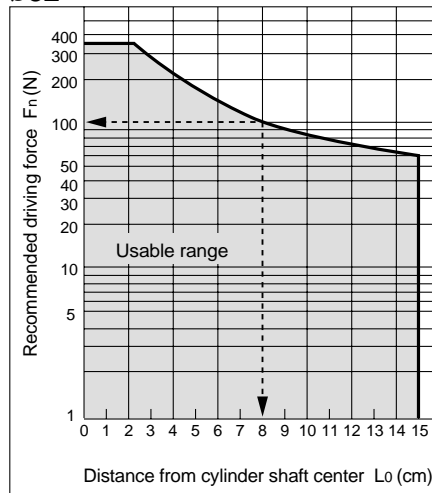

ø40

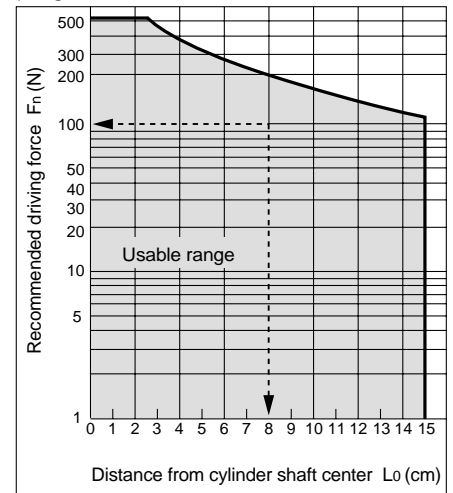

ø50

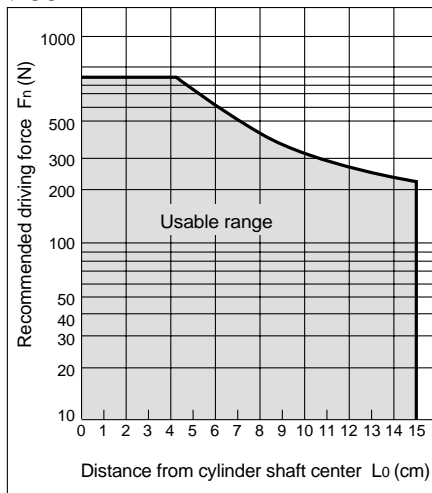

ø63

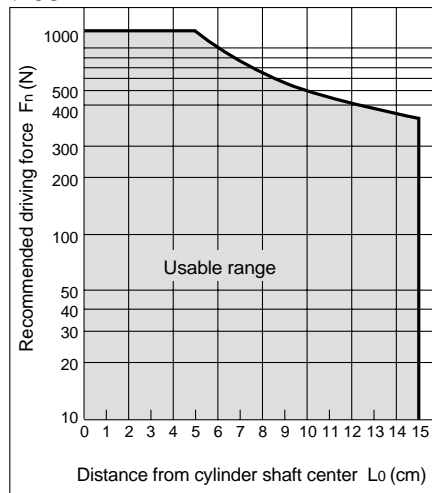

<Data B: Maximum speed — Load weight chart >

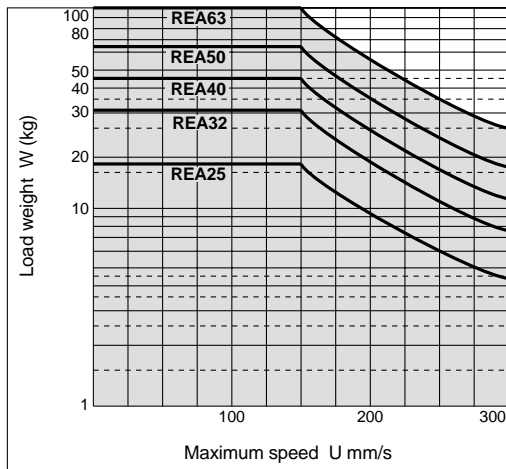



# Series REA Model Selection 3

## Design Parameters 2

### Cylinder Self Weight Deflection

When the cylinder is mounted horizontally, deflection appears due to its own weight as shown in the data, and the longer the stroke the greater the amount of variation in the shaft centers.

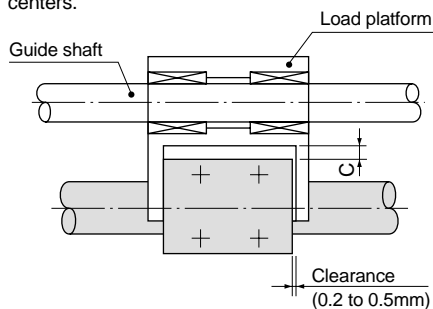

\* The clearance C is determined by considering the cylinder's self weight deflection and the amount of discrepancy with respect to the other shaft.  
Normal value: (self weight deflection) + 1.5 to 2mm

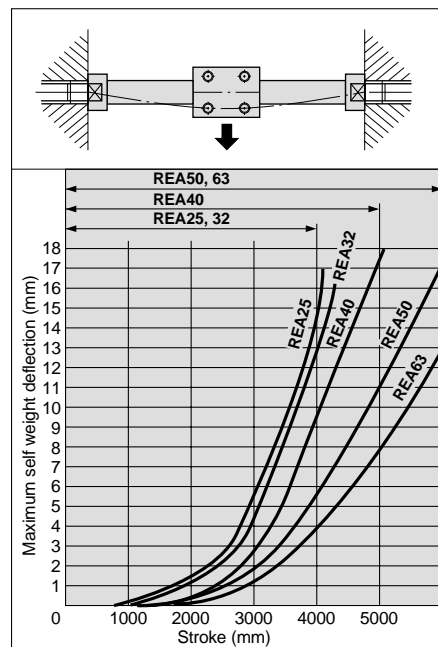

\* The above deflection data indicate values for external movement within the stroke.

### Max. Connection Fitting Weight

The REA (basic type) is not directly connected to the load, and is guided by another shaft (LM guide, etc.). Load connection fittings should be designed so that they do not exceed the weights given in the table below.

Maximum connection fitting weight  $W_{Bmax}$  (kg)

Model	Maximum load (kg)
REA25	1.2
REA32	1.5
REA40	2.0
REA50	2.5
REA63	3.0

\* Consult with SMC if weights greater than the above will be connected.

### Vertical Operation

The load should be guided by a ball type bearing (LM guide, etc.). If a slide bearing is used, sliding resistance increases due to the load weight and load moment, which can cause malfunction.

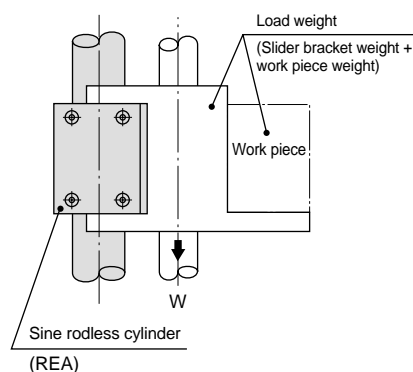

Model	Allowable load weight $W_v$ (kg)	Maximum operating pressure $P_v$ (MPa)
REA25	18.5	0.65
REA32	30.0	0.65
REA40	47.0	0.65
REA50	75.0	0.65
REA63	115.0	0.65

Note) Use caution, as operation above the maximum operating pressure may result in dislocation of the piston.

### Intermediate Stops

The cushion effect (smooth start-up, soft stop) exists only before the stroke end in the stroke ranges indicated in the table below. The cushion effect (smooth start-up, soft stop) cannot be obtained in an intermediate stop or a return from an intermediate stop using an external stopper, etc.

#### Cushion stroke

Model	Stroke (mm)
REA25	30
REA32	30
REA40	35
REA50	40
REA63	40

Max. Speed  
300  
mm/s

Basic Type  
REA

Direct Mount Type  
REAR

Slider Type/Slide Bearing  
REAS

Slider Type/Ball Bushing  
REAL

High Precision Guide Type  
REAH

Max. Speed  
600  
mm/s

Direct Mount Type  
REBR

High Precision Guide Type  
REBH

Auto Switches

Order Made

# Series REA

## Construction

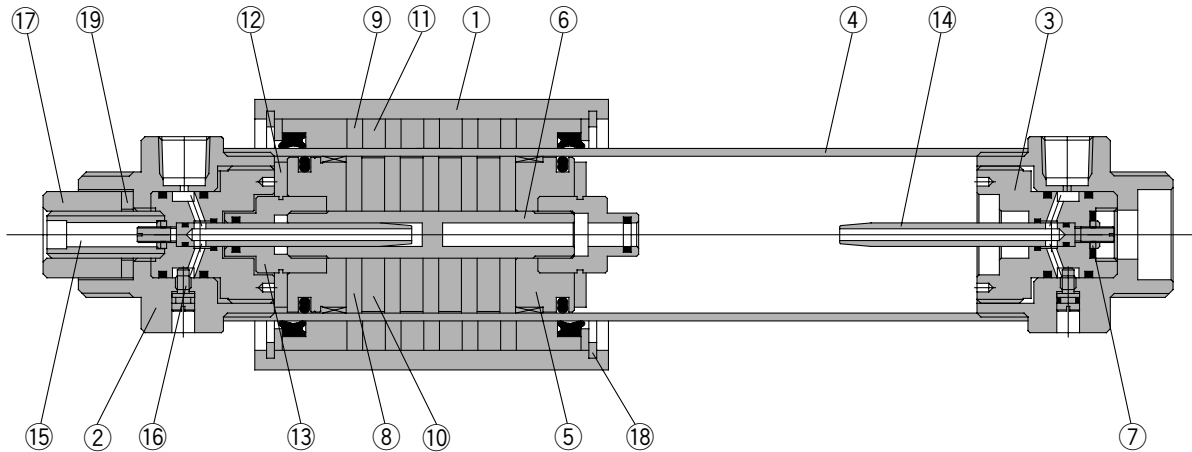

### Parts list

No.	Description	Material	Note
1	Body	Aluminum alloy	Anodized
2	Head cover	Aluminum alloy	Anodized
3	Cushion ring holder	Aluminum alloy	Chromated
4	Cylinder tube	Stainless steel	
5	Piston	Aluminum alloy	Chromated
6	Shaft	Stainless steel	
7	Lock nut B	Carbon steel	Nickel plated
8	Piston side yoke	Rolled steel	Zinc chromated
9	External slider side yoke	Rolled steel	Zinc chromated
10	Magnet A	Rare earth magnet	

No.	Description	Material	Note
11	Magnet B	Rare earth magnet	
12	Bumper	Urethane rubber	
13	Cushion seal holder	Aluminum alloy	Chromated
14	Cushion ring	Brass	Electroless nickel plated
15	Adjustment screw	Carbon steel	Nickel plated
16	Stopper bolt	Carbon steel	Nickel plated
17	Lock nut A	Carbon steel	Nickel plated
18	Snap ring	Carbon tool steel	
19	Spring washer	Steel wire	

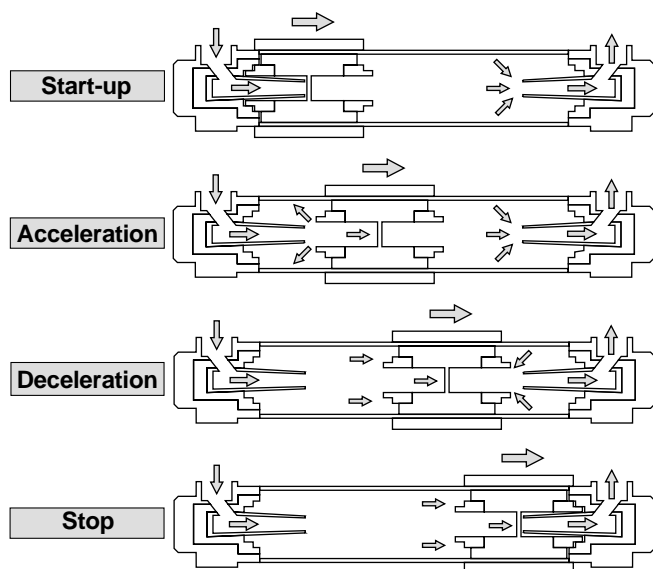

## Operating Principle

### Start-up/Acceleration

The driving air from the cylinder port passes through the inside of the cushion ring, and flows into the left chamber of the drive piston from the clearance between the cushion seal and the U-shaped groove in the outer surface of the cushion ring. Further, the exhaust air in the right chamber of the drive piston passes from inside the hollow cushion ring through the cylinder port and is released to the atmosphere by the drive solenoid valve.

When the differential pressure (thrust) generated on either side of the drive piston becomes larger than the starting resistance of the machinery, the drive piston begins to move to the right. As the drive piston moves to the right, the U-shaped groove in the outer surface of the cushion ring gradually becomes deeper, a flow corresponding to the drive speed of the drive piston flows into the left chamber of the drive piston, and the drive piston proceeds to accelerate. The U-shaped groove is machined into the cushion ring in such a way that this acceleration process can proceed smoothly (as a sine function).

### Deceleration/Stop

In conventional cushion mechanisms, when the cushion seal installed on the drive piston is pushed into the cushion ring at the right stroke end, the drive piston's right chamber is pressurized and a sudden braking force is generated. However, in a sine rodless cylinder, due to the U-shaped groove provided on the outer surface of the cushion ring, whose depth changes as a sine function, a large quantity of the air in the cushion chamber is discharged when the cushion seal is pushed in, and a sudden braking force is not generated. With the progression of the cushion stroke, the discharge flow from the cushion chamber is restricted, and therefore, a soft stop is achieved at the stroke end.

**Dimensions**

**REA 25, 32, 40**

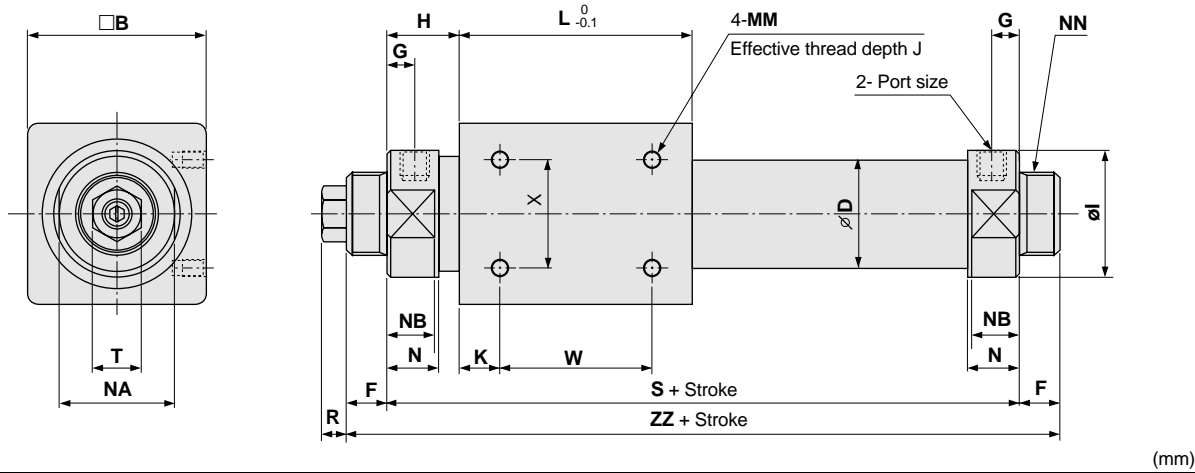

Model	Port size	B	D	F	G	H	I	K	L	MM x J	N	NA	NB	NN
REA25	Rc 1/8	46	27.8	13	8	20.5	34	10	70	M5 x 0.8 x 8	15	30	13	M26 x 1.5
REA32	Rc 1/8	60	35	16	9	22	40	15	80	M6 x 1.0 x 8	17	36	15	M26 x 1.5
REA40	Rc 1/4	70	43	16	11	29	50	16	92	M6 x 1.0 x 10	21	46	19	M32 x 2.0

Model	S	W	X	ZZ	R	T
REA25	111	50	30	137	8	17
REA32	124	50	40	156	8	17
REA40	150	60	40	182	10	19

**REA 50, 63**

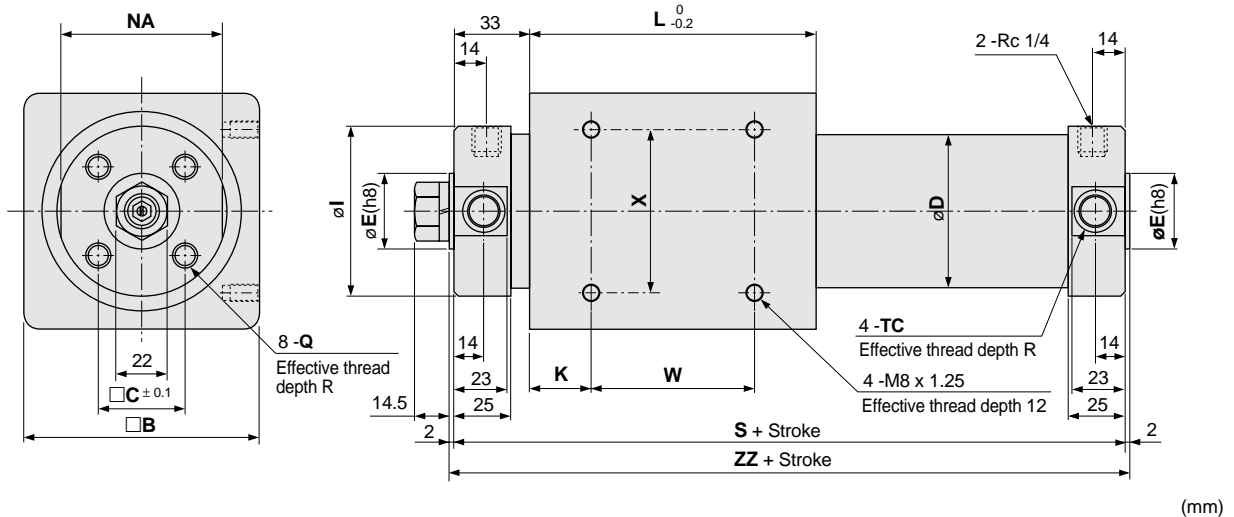

Model	B	C	D	E(h8)	I	K	L	NA	Q x R	S	TC x R	W	X	ZZ
REA50	86	32	53	30 <sup>0</sup> <sub>0.033</sub>	58.2	25	110	55	M8 x 1.25 x 16	176	M12 x 1.25 x 7.5	60	60	180
REA63	100	38	66	32 <sup>0</sup> <sub>0.039</sub>	72.2	26	122	69	M10 x 1.5 x 16	188	M14 x 1.5 x 11.5	70	70	192

**Mounting nuts: 2pcs. packaged with each cylinder**

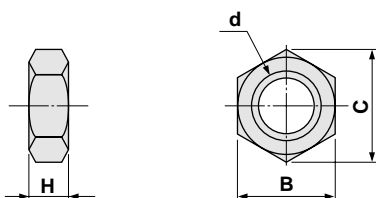

Part No.	Applicable bore size (mm)	d	H	B	C
SN-032B	ø25, ø32	M26 x 1.5	8	32	37
SN-040B	ø40	M32 x 2.0	11	41	47.3

# Series REAR

## Direct Mount Type

∅10, ∅15, ∅20, ∅25, ∅32, ∅40

### How to Order

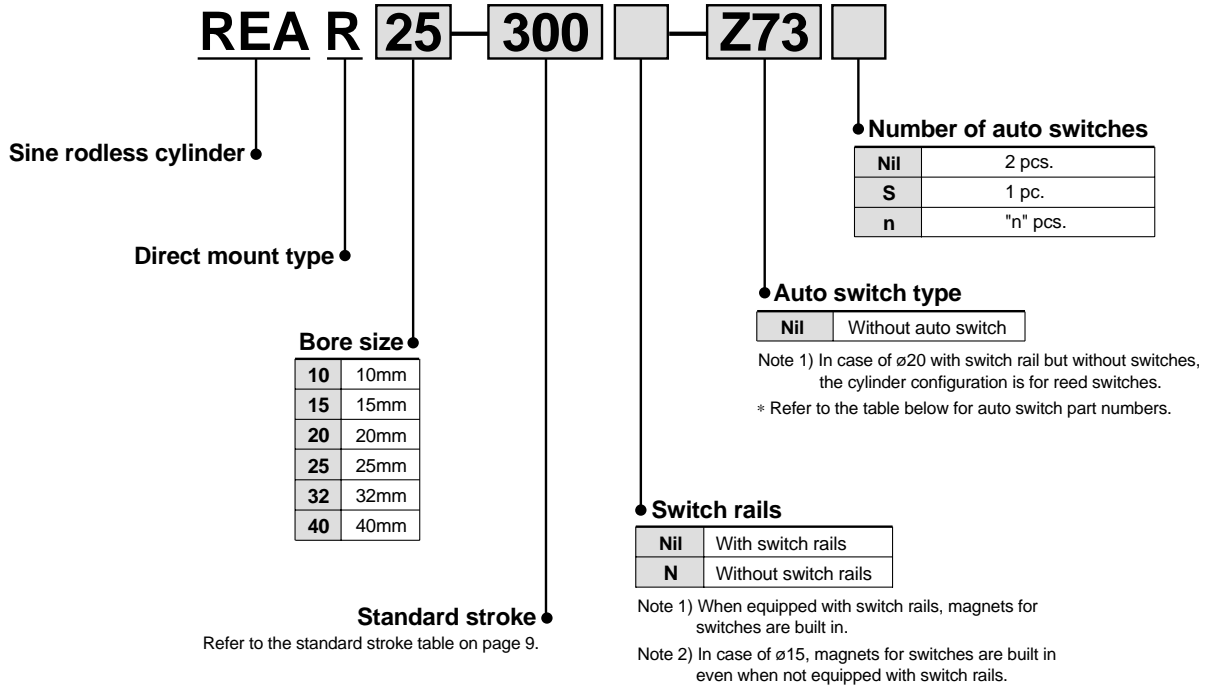

#### Applicable auto switches For ∅10, ∅15, ∅20

Refer to "Auto Switch Guide" (E274-A) for further details on auto switch units.  
Refer to pages 84 and 85 for auto switch circuit diagrams.

Type	Special function	Electrical entry	Indicator light	Wiring (output)	Load voltage			Auto switch model	Lead wire length (m) <sup>Note 1)</sup>			Applicable load		
					DC	AC			0.5 (Nil)	3 (L)	5 (Z)			
Reed switch	—	Grommet	No	2 wire	24V	5, 12V	100V or less	A90	●	●	—	IC circuit	Relay, PLC	
			Yes			12V	100V		A93	●	●	—		—
Solid state switch	—	Grommet	Yes	3 wire (NPN)	24V	12V	—	F9N	●	●	—	—	Relay, PLC	
				3 wire (PNP)					F9P	●	●			—
				2 wire					F9B	●	●			—

Note 1) Lead wire length symbol 0.5m ..... Nil (Example) F9N  
3m ..... L F9NL

#### For ∅25, ∅32, ∅40

Type	Special function	Electrical entry	Indicator light	Wiring (output)	Load voltage			Auto switch model	Lead wire length (m) <sup>Note 1)</sup>			Applicable load		
					DC	AC			0.5 (Nil)	3 (L)	5 (Z)			
Reed switch	—	Grommet	Yes	3 wire	24V	5V	—	Z76	●	●	—	IC circuit	—	
				2 wire		12V	100V		Z73	●	●	●		—
			No	5, 12V	100V or less	Z80	●	●	—	IC circuit	Relay, PLC			
Solid state switch	—	Grommet	Yes	3 wire (NPN)	24V	5, 12V	—	Y59A	●	●	○	IC circuit	Relay, PLC	
				3 wire (PNP)					Y7P	●	●	○		
				2 wire					Y59B	●	●	○		—
				3 wire (NPN)					Y7NW	●	●	○		IC circuit
				3 wire (PNP)					Y7PW	●	●	○		IC circuit
				2 wire					Y7BW	●	●	○		—

Note 1) Lead wire length symbol 0.5m ..... Nil (Example) Y59A  
3m ..... L Y59AL  
5m ..... Z Y59AZ

Note 2) Solid state auto switches marked with a "○" are produced upon receipt of order.

## Specifications

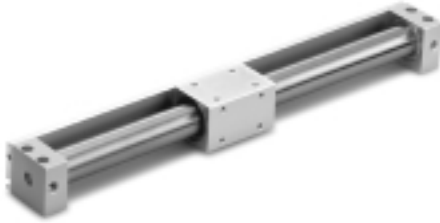

Fluid	Air
Proof pressure	1.05MPa
Maximum operating pressure	0.7MPa
Minimum operating pressure	0.18MPa
Ambient and fluid temperature	-10 to 60°C
Piston speed	50 to 300mm/s
Lubrication	Non-lube
Stroke length tolerance	0 to 250st: $+1.0_0$ , 251 to 1000st: $+1.4_0$ , 1001st and up: $+1.8_0$
Mounting	Direct mount type

## Standard Strokes

Bore size (mm)	Standard stroke (mm)	Maximum manufacturable stroke (mm)	Maximum stroke with switch (mm)
10	150, 200, 250, 300	500	500
15	150, 200, 250, 300, 350, 400, 450, 500	1000	750
20	200, 250, 300, 350, 400, 450, 500, 600, 700, 800	1500	1000
25		2000	1500
32			
40	200, 250, 300, 350, 400, 450, 500, 600, 700, 800, 900, 1000	2000	1500

Note) Intermediate strokes can be arranged in 1mm increments.

## Magnetic Holding Force

Bore size (mm)	10	15	20	25	32	40
Holding force (N)	53.9	137	231	363	588	922

## Weights

Item	Bore size (mm)						
	10	15	20	25	32	40	
Basic weight (for 0st)	REAR□ (with switch rail)	0.111	0.277	0.440	0.660	1.27	2.06
	REAR□-□N (without switch rail)	0.080	0.230	0.370	0.580	1.15	1.90
Additional weight per 50mm stroke (when equipped with switch rail)	0.034	0.045	0.071	0.083	0.113	0.133	
Additional weight per 50mm stroke (when not equipped with switch rail)	0.014	0.020	0.040	0.050	0.070	0.080	

Calculation method/Example: REAR25-500 (with switch rail)  
Basic weight ... 0.660kg, Additional weight ... 0.083kg/50mm, Cylinder stroke ... 500mm  
 $0.660 + 0.083 \times 500 \div 50 = 1.49\text{kg}$

## ⚠ Specific Product Precautions

Be sure to read before handling. Refer to pages 92 through 94 for safety instructions and actuator precautions.

### Mounting

#### ⚠ Caution

- 1. Take care to avoid nicks or other damage on the outside surface of the cylinder tube.**  
This can lead to damage of the scraper and wear ring, which in turn can cause malfunction.
- 2. Pay attention to the rotation of the external slider.**  
Rotation should be controlled by connecting it to another shaft (linear guide, etc.).
- 3. Do not operate with the magnetic coupling out of position.**  
In case the magnetic coupling is out of position, push the external slider back into the correct position by hand at the end of the stroke (or correct the piston slider with air pressure).
- 4. The cylinder is mounted with bolts through the mounting holes in the end covers. Be sure they are tightened securely.**
- 5. Be sure that both end covers are secured to the mounting surface before operating the cylinder.**  
Avoid operation with the external slider secured to the surface.
- 6. Do not apply a lateral load to the external slider.**  
When a load is mounted directly to the cylinder, variations in the alignment of each shaft center cannot be offset, which results in the generation of a lateral load that can cause malfunction. The cylinder should be operated using a connection method which allows for shaft alignment variations and deflection due to the cylinder's own weight. A drawing of a recommended mounting is shown in Figure 2.

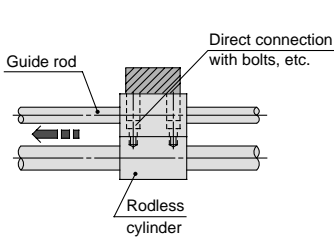

Variations in the load and cylinder shaft alignment cannot be offset and may result in a malfunction.

**Figure 1.**  
Incorrect mounting

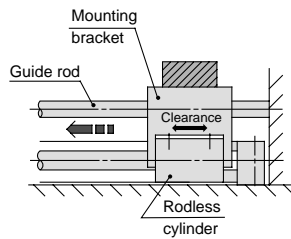

Shaft alignment variations are offset by providing clearance between the mounting bracket and cylinder. Moreover, the mounting bracket is extended above the cylinder shaft center, so that the cylinder is not subjected to moment.

**Figure 2.**  
Recommended mounting

- 7. Use caution regarding the allowable load weight when operating in a vertical direction.**

The allowable load weight when operating in a vertical direction (reference values on page 13) is determined by the model selection method. However, if a load greater than the allowable value is applied, the magnetic coupling may break and there is a possibility of dropping the load. When using this type of application, contact SMC regarding the operating conditions (pressure, load, speed, stroke, frequency, etc.).

### Disassembly & Maintenance

#### ⚠ Caution

- 1. Special tools are necessary for disassembly.**

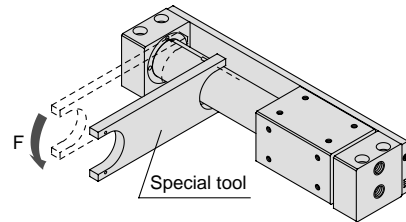

#### Special tool number list

No.	Applicable bore size (mm)
CYRZ-V	10, 15, 20
CYRZ-W	25, 32, 40

# Series REAR Model Selection 1

**F<sub>n</sub>**: Allowable driving force (N)  
**M<sub>d</sub>**: Maximum allowable moment when connection fitting, etc., is directly loaded (N·m)  
**P<sub>v</sub>**: Maximum operating pressure for vertical operation (MPa)  
**W<sub>Bmax</sub>**: Maximum load weight when loaded directly on the body (kg)  
**W<sub>v</sub>**: Allowable load weight for vertical operation (kg)

- Operating conditions**
- **W**: Load weight (kg)
  - **W<sub>B</sub>**: Connection fitting weight (kg)
  - **μ**: Guide's coefficient of friction
  - **L<sub>o</sub>**: Distance from cylinder shaft center to work piece point of application (cm)
  - **L<sub>1</sub>**: Distance from cylinder shaft center to center of gravity of connection fitting, etc. (mm)
  - Presence of switches
  - **P**: Operating pressure (MPa)
  - **U**: Maximum Speed (mm/s)
  - Stroke (mm)
  - Mode of operation (horizontal, inclined, vertical)

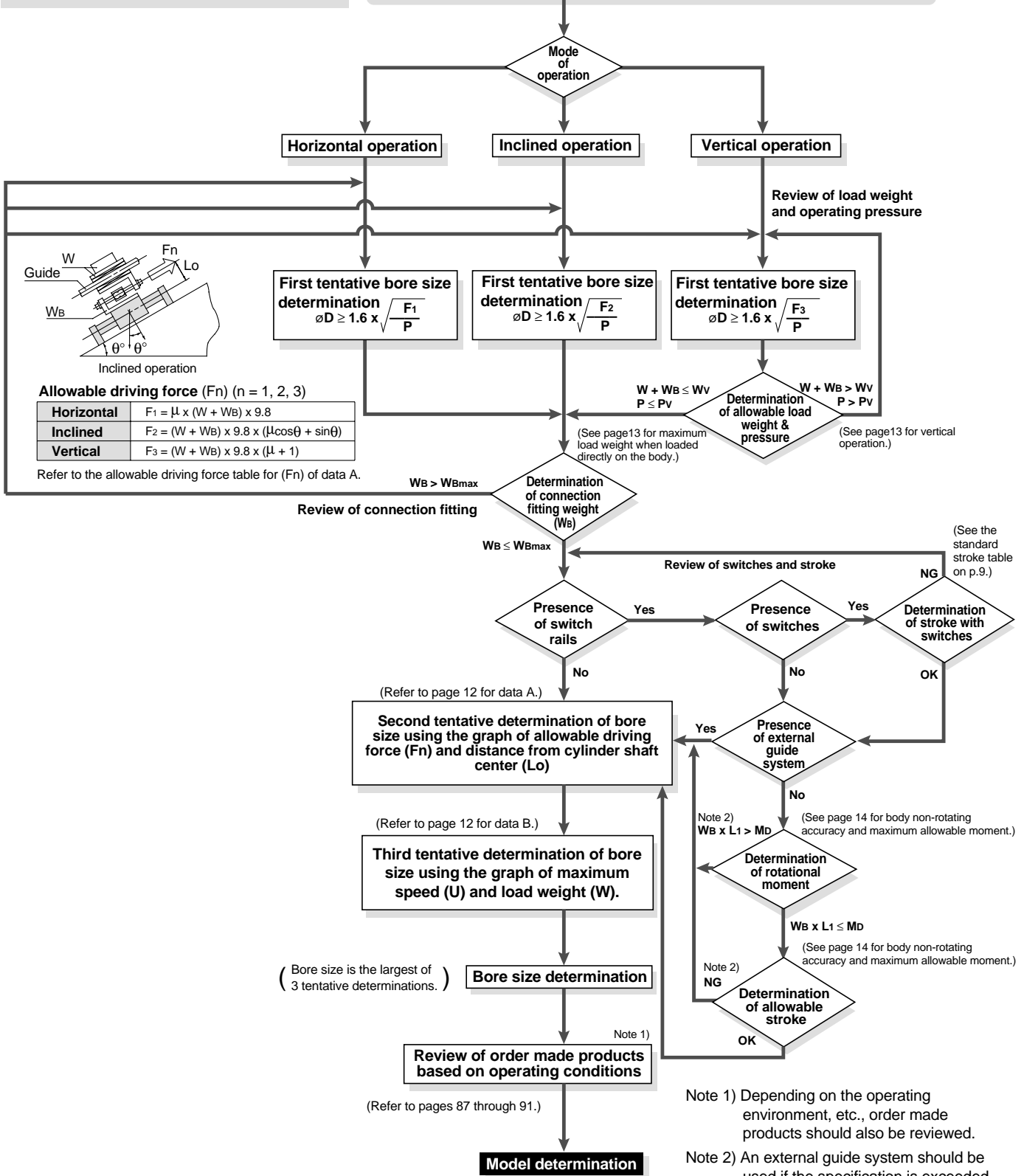

Note 1) Depending on the operating environment, etc., order made products should also be reviewed.  
 Note 2) An external guide system should be used if the specification is exceeded.

Max. Speed  
300  
mm/s

Basic Type  
REAR

Direct Mount Type  
REAR

Slider Type/Slide Bearing  
REAS

Slider Type/Ball Bushing  
REAL

High Precision Guide Type  
REAH

Max. Speed  
600  
mm/s

Direct Mount Type  
REBR

High Precision Guide Type  
REBH

Auto Switches

Order Made

# Series REAR Model Selection 2

## Design Parameters 1

### Selection Method

<Data A: Distance from cylinder shaft center — Allowable driving capacity>

**REAR10**

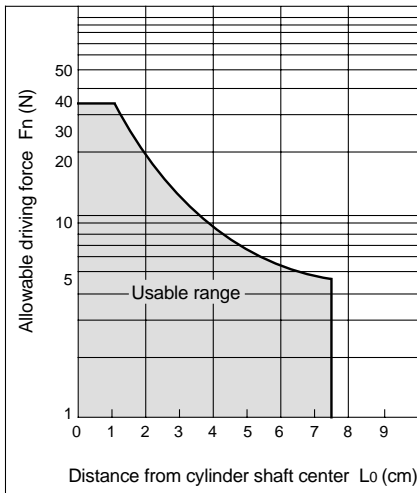

**REAR20**

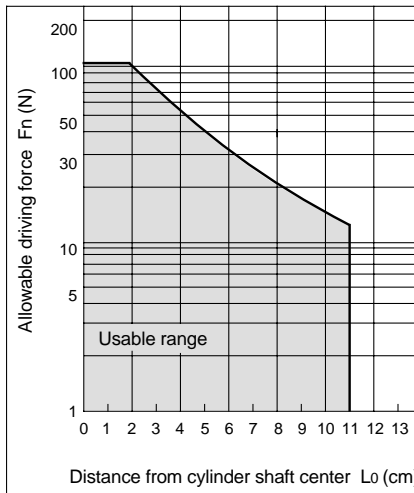

**REAR32**

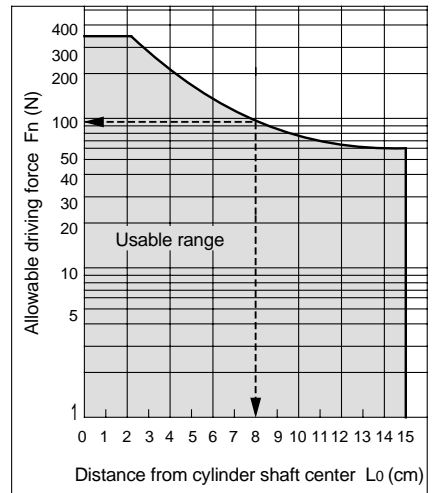

**REAR15**

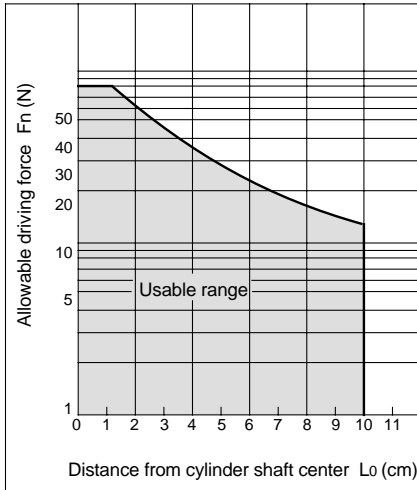

**REAR25**

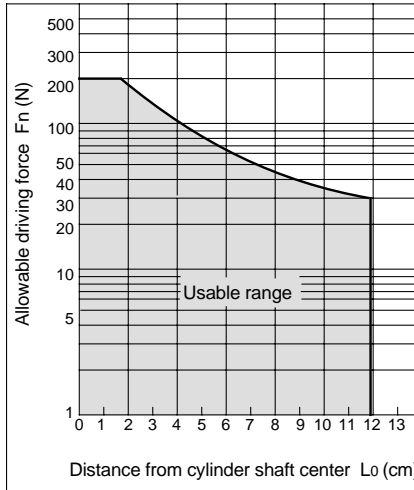

**REAR40**

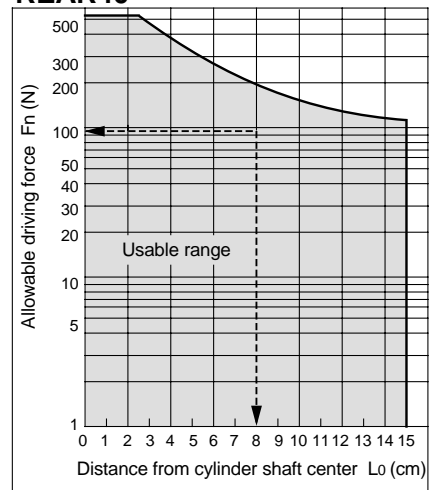

<Data B: Maximum speed — Load weight chart >

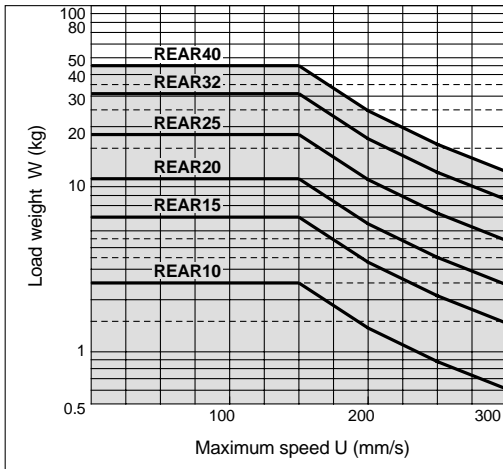



# Series REAR Model Selection 3

## Design Parameters 2

### Cylinder Self Weight Deflection

When the cylinder is mounted horizontally, deflection appears due to its own weight as shown in the data, and the longer the stroke, the greater the amount of variation in the shaft centers. Therefore, a connection method should be considered which allows for this variation as shown in the drawing.

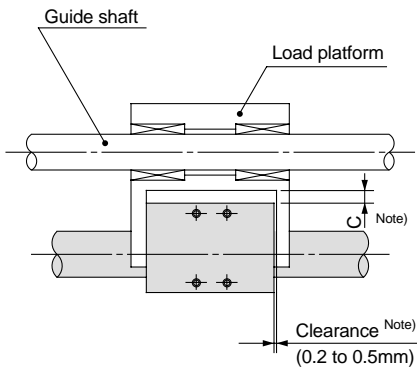

Note) Referring to the self weight deflection in the figure below, provide clearance so that the cylinder is able to operate smoothly through the full stroke within the minimum operating pressure range, without touching the mounting surface or the load, etc.

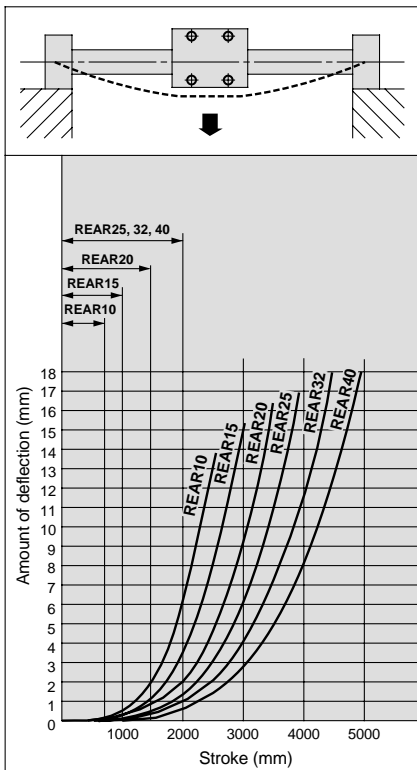

\* The above deflection data indicate values when the external slider has moved to the middle of the stroke.

### Vertical Operation

The load should be guided by a ball type bearing (LM guide, etc.). If a slide bearing is used, sliding resistance will increase due to the load weight and moment, and this can cause malfunction.

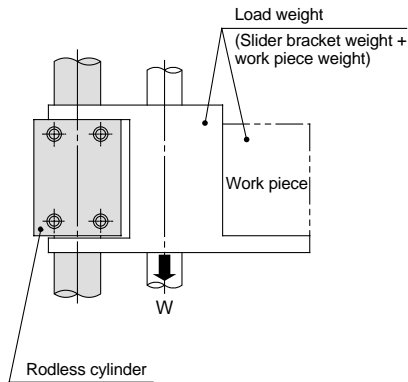

Cylinder bore size (mm)	Model	Allowable load weight $W_v$ (kg)	Max. operating pressure $P_v$ (MPa)
10	REAR10	2.7	0.55
15	REAR15	7.0	0.65
20	REAR20	11.0	0.65
25	REAR25	18.5	0.65
32	REAR32	30.0	0.65
40	REAR40	47.0	0.65

Note) Use caution, as operation above the maximum operating pressure can result in breaking of the magnetic coupling.

### Max. Load Weight when Loaded Directly on Body

When the load is applied directly to the body, it should be no greater than the maximum values shown in the table below.

Model	Maximum load weight $W_{max}$ (kg)
REAR10	0.4
REAR15	1.0
REAR20	1.1
REAR25	1.2
REAR32	1.5
REAR40	2.0

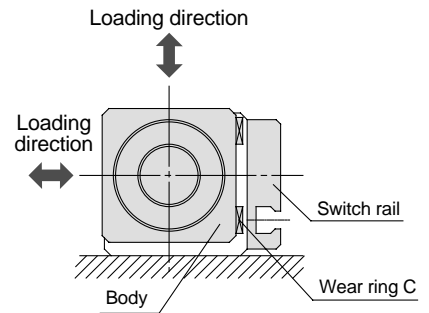

Max. Speed  
300  
mm/s

Basic Type  
REAR

Direct Mount Type  
REAR

Slider Type/Slide Bearing  
REAS

Slider Type/Ball Bushing  
REAL

High Precision Guide Type  
REAH

Max. Speed  
600  
mm/s

Direct Mount Type  
REBR

High Precision Guide Type  
REBH

Auto Switches

Order Made

# Series REAR Model Selection 4

## Design Parameters 3

### Intermediate Stops

The cushion effect (smooth start-up, soft stop) exists only before the stroke end in the stroke ranges indicated in the table below.

The cushion effect (smooth start-up, soft stop) cannot be obtained in an intermediate stop or a return from an intermediate stop using an external stopper, etc.

#### Cushion Stroke

Model	Stroke (mm)
<b>REAR10</b>	20
<b>REAR15</b>	25
<b>REAR20</b>	30
<b>REAR25</b>	30
<b>REAR32</b>	30
<b>REAR40</b>	35

### Body Non-rotating Accuracy and Maximum Allowable Moment (with Switch Rail) (Reference Values)

Reference values for non-rotating accuracy and maximum allowable moment at stroke end are indicated below.

Bore size (mm)	Non-rotating accuracy (°)	Max. allowable moment (M <sub>0</sub> ) (N·m)	Allowable stroke (mm) <sup>Note 2)</sup>
<b>10</b>	6.0	0.05	100
<b>15</b>	4.5	0.15	200
<b>20</b>	3.7	0.20	300
<b>25</b>	3.7	0.25	300
<b>32</b>	3.1	0.40	400
<b>40</b>	2.8	0.62	400

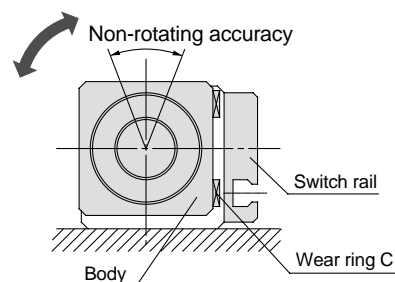

Note 1) Avoid operations where rotational torque (moment) is applied. In such a case, the use of an external guide is recommended.

Note 2) The above reference values will be satisfied within the allowable stroke ranges. However, caution is necessary because as the stroke becomes longer the inclination (rotation angle) within the stroke can be expected to increase.

Note 3) When a load is applied directly to the body, the loaded weight should be no greater than the allowable load weights on page 13.

**Construction/ø10, ø15**

Max. Speed  
**300**  
mm/s

Basic Type  
**REA**

Direct Mount Type  
**REAR**

Slider Type/Slide Bearing  
**REAS**

Slider Type/Ball Bushing  
**REAL**

High Precision Guide Type  
**REAH**

Max. Speed  
**600**  
mm/s

Direct Mount Type  
**REBR**

High Precision Guide Type  
**REBH**

Auto Switches

Order Made

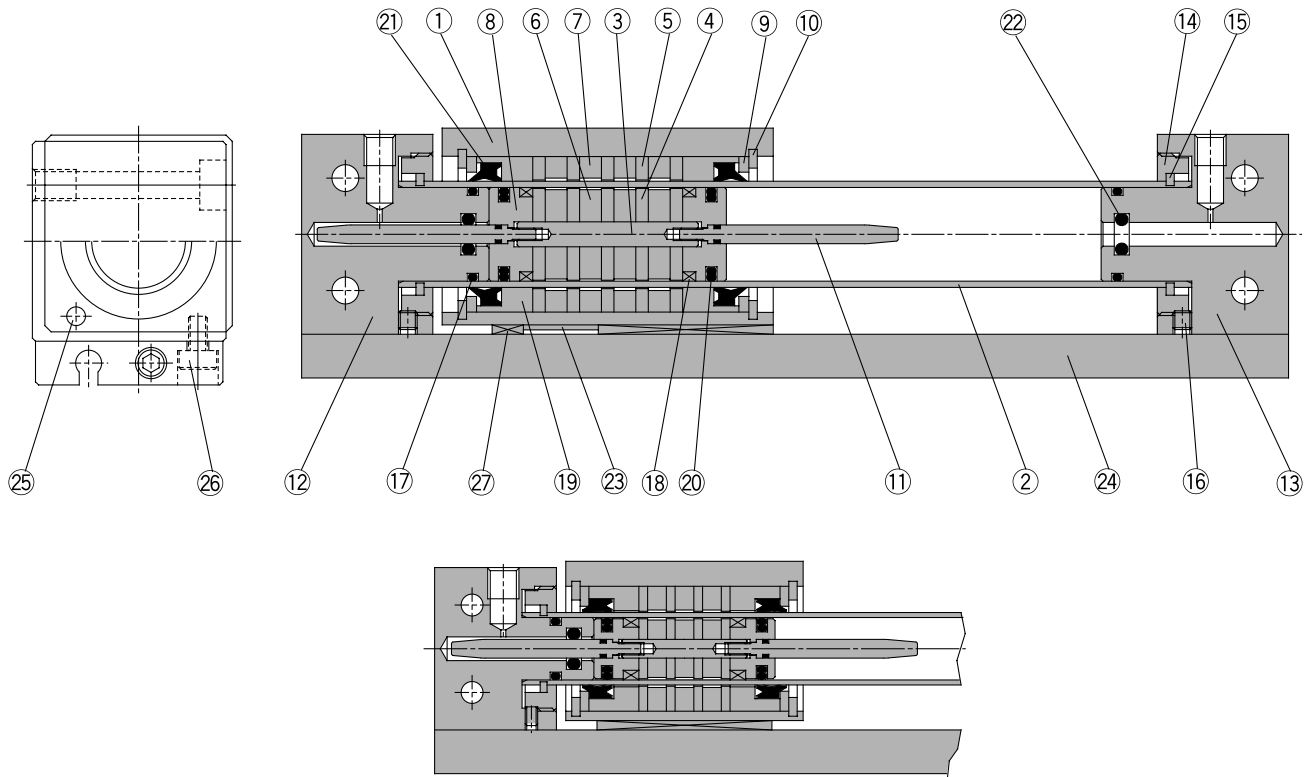

**REAR10**

**Parts list**

No.	Description	Material	Note
1	Body	Aluminum alloy	Hard anodized
2	Cylinder tube	Stainless steel	
3	Shaft	Stainless steel	
4	Piston side yoke	Rolled steel plate	Zinc chromated
5	External slider side yoke	Rolled steel plate	Zinc chromated
6	Magnet A	Rare earth magnet	
7	Magnet B	Rare earth magnet	
8	Piston	Brass	Electroless nickel plated
9	Spacer	Rolled steel plate	Nickel plated
10	Snap ring	Carbon tool steel	Nickel plated
11	Cushion ring	Stainless steel	
12	End cover A	Aluminum alloy	Hard anodized
13	End cover B	Aluminum alloy	Hard anodized
14	Attachment ring	Aluminum alloy	Hard anodized
15	C type snap ring for shaft	Stainless steel	REAR10
		Hard steel wire	Nickel plated (REAR15)
16	Hexagon socket head set screw	Chromium steel	Nickel plated
17*	Cylinder tube gasket	NBR	

**Parts list**

No.	Description	Material	Note
18*	Wear ring A	Special resin	
19*	Wear ring B	Special resin	
20*	Piston seal	NBR	
21*	Scraper	NBR	
22*	Cushion seal	NBR	
23	Magnetic shielding plate	Rolled steel plate	Chromated
24	Switch rail	Aluminum alloy	Clear anodized
25	Magnet	Rare earth magnet	
26	Hexagon socket head screw	Chromium steel	Nickel plated
27*	Wear ring C	Special resin	

\* Seal kits are sets consisting of numbers 17 through 22 above, and can be ordered using the order number for each bore size.

**Replacement parts: Seal kits**

Bore size (mm)	Order no.	Content
10	<b>REAR10-PS</b>	Above numbers 17, 18, 19, 20, 21, 22, 27
15	<b>REAR15-PS</b>	

**Switch Rail Accessory Kits**

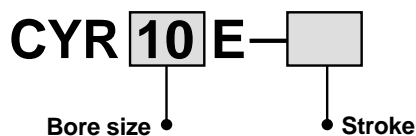

**Switch rail accessory kits**

Bore size (mm)	Kit no.	Content
10	<b>CYR10E-□</b>	Above numbers 24, 25, 26, 27
15	<b>CYR15E-□</b>	Above numbers 23, 24, 26, 27 <sup>Note 2)</sup>

Note 1) □ indicates the stroke.  
Note 2) ø15 has internal magnets in the body.

# Series REAR

## Construction/ø20 to ø40

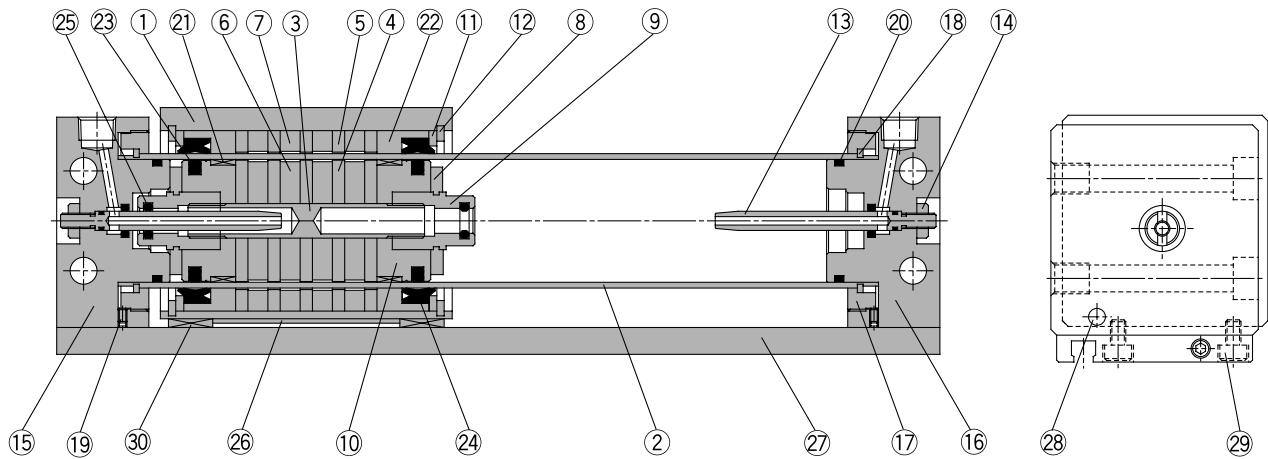

### Parts list

No.	Description	Material	Note
1	Body	Aluminum alloy	Hard anodized
2	Cylinder tube	Stainless steel	
3	Shaft	Stainless steel	
4	Piston side yoke	Rolled steel plate	Zinc chromated
5	External slider side yoke	Rolled steel plate	Zinc chromated
6	Magnet A	Rare earth magnet	
7	Magnet B	Rare earth magnet	
8	Bumper	Urethane rubber	
9	Cushion seal holder	Aluminum alloy	Chromated
10	Piston	Aluminum alloy	Chromated
11	Spacer	Rolled steel plate	Nickel plated
12	Snap ring	Carbon tool steel	Nickel plated
13	Cushion ring	Brass	Electroless nickel plated (REAR 32, 40)
		Stainless steel	REAR 20, 25
14	Lock nut B	Carbon steel	Nickel plated
15	End cover A	Aluminum alloy	Hard anodized
16	End cover B	Aluminum alloy	Hard anodized
17	Attachment ring	Aluminum alloy	Hard anodized
18	C type snap ring for shaft	Stainless steel	REAR 25, 32
		Hard steel wire	Nickel plated (REAR 20, 40)
19	Hexagon socket head set screw	Chromium steel	Nickel plated
20*	Cylinder tube gasket	NBR	

### Parts list

No.	Description	Material	Note
21*	Wear ring A	Special resin	
22*	Wear ring B	Special resin	
23*	Piston seal	NBR	
24*	Scraper	NBR	
25*	Cushion seal	NBR	
26	Magnetic shielding plate	Rolled steel plate	Chromated
27	Switch rail	Aluminum alloy	Clear anodized
28	Magnet	Rare earth magnet	
29	Hexagon socket head screw	Chromium steel	Nickel plated
30*	Wear ring C	Special resin	

\* Seal kits are sets consisting of numbers 20 through 25 and 30 above, and can be ordered using the kit number for each bore size.

### Replacement parts: Seal kits

Bore size (mm)	Kit no.	Content
20	REAR20-PS	Above numbers 20, 21, 22, 23, 24, 25, 30
25	REAR25-PS	
32	REAR32-PS	
40	REAR40-PS	

## Switch Rail Accessory Kits

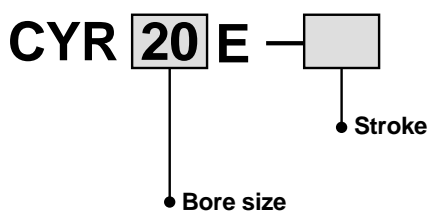

### Switch rail accessory kits

Bore size (mm)		Kit no.	Content
20	For reed switch	CYR20E-□	Above numbers 26, 27, 28, 29, 30
	For solid state	CYR20EN-□	
25		CYR25E-□	
32		CYR32E-□	
40		CYR40E-□	

Note 1) □ indicates the stroke.

**Dimensions**

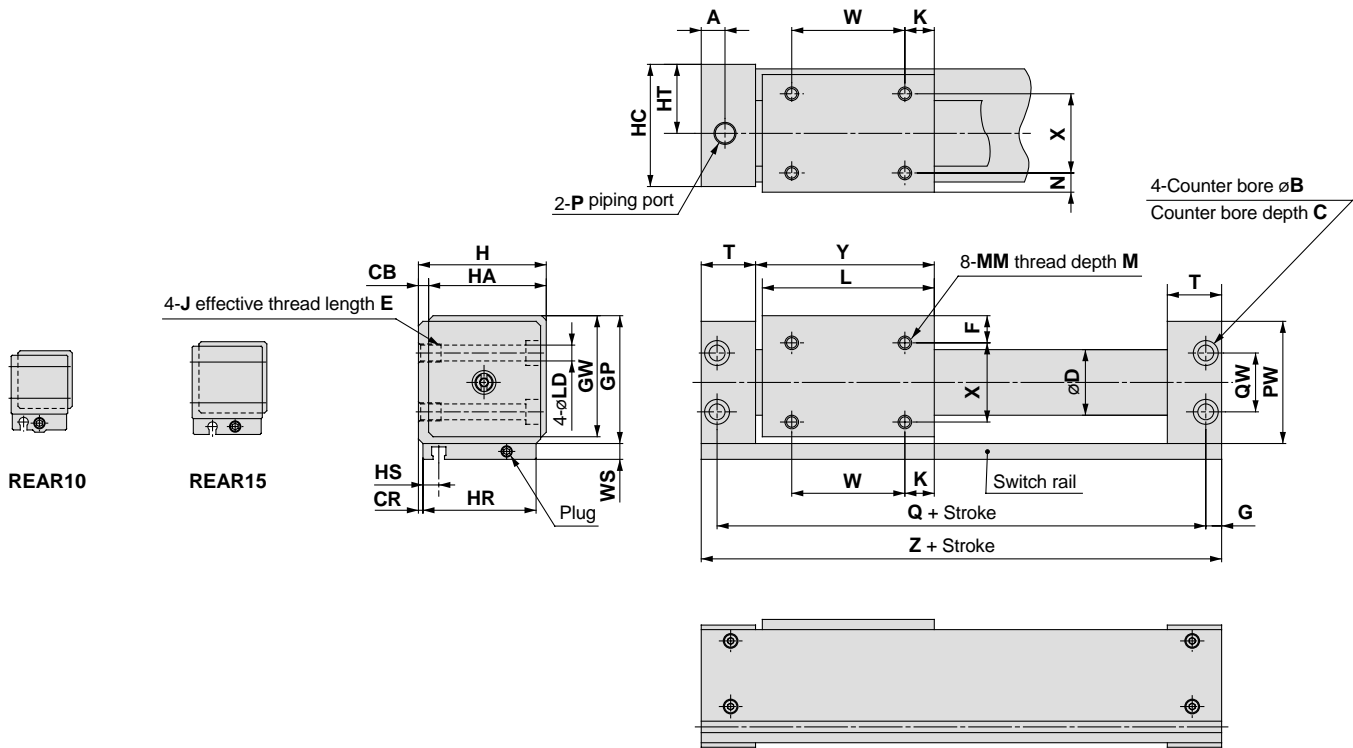

(mm)

Model	A	B	C	CB	CR	D	F	G	GP	GW	H	HA	HC	HR	HS	HT	J x E
REAR10	10.5	6.5	3.2	2	0.5	12	6.5	6	27	25.5	26	24	25	24	5	14	M4 x 0.7 x 6
REAR15	12	8	4.2	2	0.5	17	8	7	33	31.5	32	30	31	30	8.5	17	M5 x 0.8 x 7
REAR20	9	9.5	5.2	3	1	22.8	9	6	39	37.5	39	36	38	36	7.5	21	M6 x 1 x 8
REAR25	8.5	9.5	5.2	3	1	27.8	8.5	6	44	42.5	44	41	43	41	6.5	23.5	M6 x 1 x 8
REAR32	10.5	11	6.5	3	1.5	35	10.5	7	55	53.5	55	52	54	51	7	29	M8 x 1.25 x 10
REAR40	10	11	6.5	5	2	43	13	7	65	63.5	67	62	66	62	8	36	M8 x 1.25 x 10

Model	K	L	LD	M	MM	N	P	PW	Q	QW	T	W	WS	X	Y	Z
REAR10	9	38	3.5	4	M3 x 0.5	4.5	M5 x 0.8	26	68	14	19.5	20	8	15	39.5	80
REAR15	14	53	4.3	5	M4 x 0.7	6	M5 x 0.8	32	84	18	21	25	7	18	54.5	98
REAR20	11	62	5.6	5	M4 x 0.7	7	Rc 1/8	38	95	17	20.5	40	7	22	64	107
REAR25	15	70	5.6	6	M5 x 0.8	6.5	Rc 1/8	43	105	20	21.5	40	7	28	72	117
REAR32	13	76	7	7	M6 x 1	8.5	Rc 1/8	54	116	26	24	50	7	35	79	130
REAR40	15	90	7	8	M6 x 1	11	Rc 1/4	64	134	34	26	60	7	40	93	148

Max. Speed  
300  
mm/s

Basic Type  
REAR

Direct Mount Type  
REAR

Slider Type/Slide Bearing  
REAS

Slider Type/Ball Bushing  
REAL

High Precision Guide Type  
REAH

Max. Speed  
600  
mm/s

Direct Mount Type  
REBR

High Precision Guide Type  
REBH

Auto Switches

Order Made

# Series REAR

## Proper Auto Switch Mounting Position for Stroke End Detection

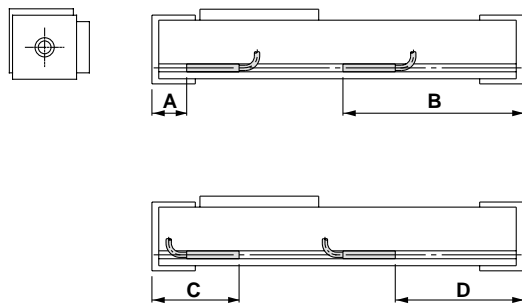

## Auto Switch Operation Range

Bore size (mm)	Auto switch model			
	D-A9□	D-F9□	D-Z7□ D-Z8□	D-Y5□ D-Y7□ D-Y7□W
10	13	7	—	—
15	8	5	—	—
20	6	4	—	—
25	—	—	9	7
32	—	—	9	6
40	—	—	11	6

Note 1) Switches cannot be mounted in some cases.

Note 2) Operating ranges are standards including hysteresis, and are not guaranteed. Large variations may occur depending on the surrounding environment (variations on the order of ±30%).

### ø10 to ø20

Bore size (mm)	Auto switch model		A		B		C		D	
	D-A9□	D-F9□	D-A9□	D-F9□	D-A9□	D-F9□	D-A9□	D-F9□	D-A9□	D-F9□
10	28	32	48	44	48	44	28	32		
15	17.5	21.5	76.5	72.5	—	—	56.5	60.5		
20	19.5	23.5	87.5	83.5	39.5	35.5	67.5	71.5		

Note) Auto switches cannot be installed in Area C in the case of ø15.

### ø25 to ø40

Bore size (mm)	Auto switch model		A		B		C		D	
	D-Z7□ D-Z8□	D-Y5□ D-Y7□ D-Y7□W	D-Z7□ D-Z8□	D-Y5□ D-Y7□ D-Y7□W	D-Z7□ D-Z8□	D-Y5□ D-Y7□ D-Y7□W	D-Z7□ D-Z8□	D-Y5□ D-Y7□ D-Y7□W	D-Z7□ D-Z8□	D-Y5□ D-Y7□ D-Y7□W
25	18	18	97	99	43	43	74	74		
32	21.5	21.5	108.5	108.5	46.5	46.5	83.5	83.5		
40	23.5	23.5	124.5	124.5	48.5	48.5	99.5	99.5		

## Auto Switch Mounting

When mounting auto switches, they should be inserted into the cylinder's switch groove from the direction shown in the drawing on the right. After setting in the mounting position, use a flat head watchmakers screw driver to tighten the mounting screw which is included.

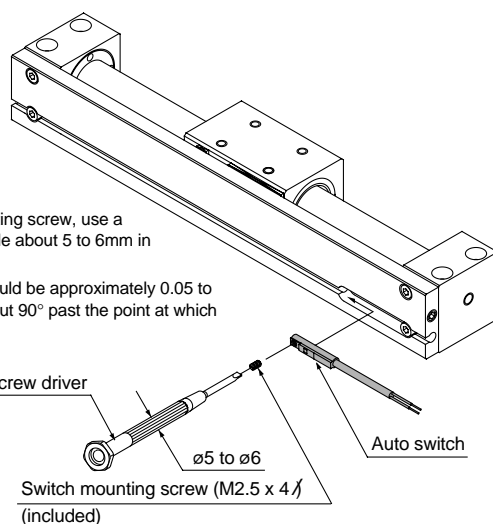

Note) When tightening the auto switch mounting screw, use a watchmakers screw driver with a handle about 5 to 6mm in diameter.

Furthermore, the tightening torque should be approximately 0.05 to 0.1N·m. As a rule, it can be turned about 90° past the point at which tightening can be felt.

## Auto Switch Specifications

- (1) Switches (switch rail) can be added to the standard type (without switch rail). Switch rail accessory kits are mentioned on pages 15 and 16 and can be ordered together with auto switches.
- (2) Refer to the separate disassembly instructions for switch magnet installation procedures.

# Series REAS

## Slider Type/Slide Bearing

Max. Speed  
300  
mm/s

Basic Type  
REA

Direct Mount Type  
REAR

Slider Type/Slide Bearing  
REAS

Slider Type/Ball Bushing  
REAL

High Precision Guide Type  
REAH

Max. Speed  
600  
mm/s

Direct Mount Type  
REBR

High Precision Guide Type  
REBH

Auto Switches

Order Made

### How to Order

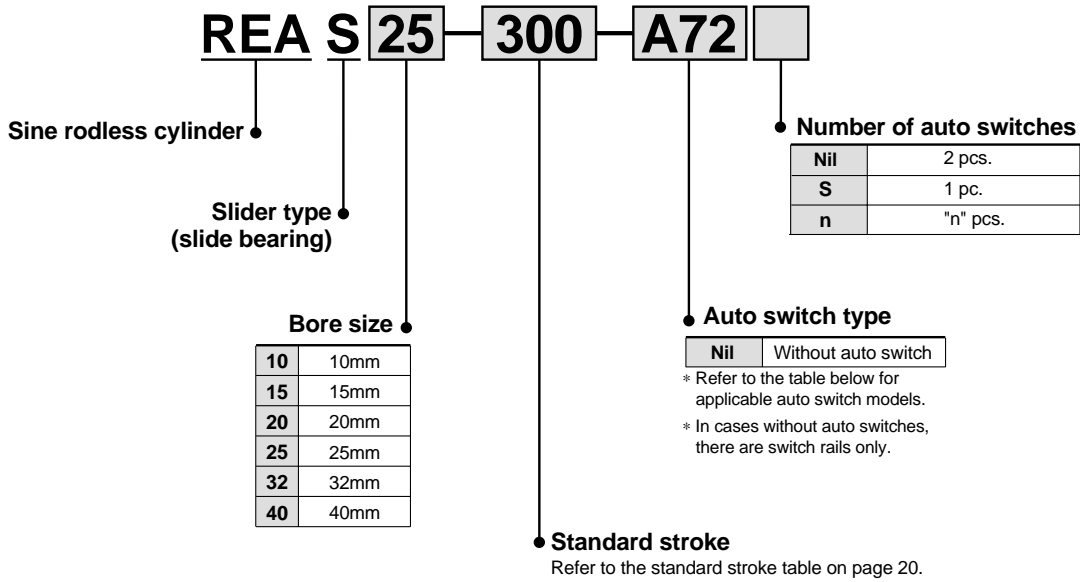

### Applicable auto switches

Refer to "Auto Switch Guide" (E-274-A) for further details on auto switch units.  
Refer to pages 84 and 85 for auto switch circuit diagrams.

Type	Special function	Electrical entry	Indicator light	Wiring (output)	Load voltage		Auto switch model		Lead wire length (m) <sup>Note 1)</sup>				Applicable load				
					DC	AC	Electrical entry direction		0.5 (Nil)	3 (L)	5 (Z)	None (N)					
							Perpendicular	In-line									
Reed switches	—	Grommet	Yes	3 wire (NPN equiv.)	—	5V	—	A76H	●	●	—	—	IC circuit	—			
				2 wire	—	—	200V	A72	A72H	●	●	—	—	—	Relay, PLC		
					24V	5V, 12V	100V or less	A73	A73H	●	●	●	—	—		IC circuit	
		Connector	No	Yes		12V	—	—	A80	A80H	●	●	—	—	IC circuit	—	
				No	5V, 12V	24V or less	A73C	—	●	●	●	●	—	—	IC circuit	—	
		Solid state switches	—	Grommet	—	3 wire (NPN)	5V, 12V	—	—	F7NV	F79	●	●	○	—	IC circuit	Relay, PLC
3 wire (PNP)	F7PV					F7P				●	●	○	—	—			
2 wire	F7BV					J79				●	●	○	—	—			
Connector	—			—	3 wire (NPN)	5V, 12V	—	—	J79C	—	●	●	●	●	—	—	
					3 wire (PNP)				F7NWV	F79W	●	●	○	—	—	IC circuit	
					2 wire				—	F7PW	●	●	○	—	—	—	
Grommet	Yes			—	3 wire (NPN)	5V, 12V	—	—	F7BWV	J79W	●	●	○	—	—	—	
					3 wire (PNP)				—	F7BA	—	●	○	—	—	—	
					2 wire				—	F7NT	—	●	○	—	—	IC circuit	
Grommet	—			—	3 wire (NPN)	5V, 12V	—	—	—	F79F	●	●	○	—	—	—	
					4 wire (NPN)				—	—	—	—	—	—	—	—	—
					—				—	—	—	—	—	—	—	—	—
Grommet	—	—	—	—	—	—	—	F7LF <sup>Note 3)</sup>	●	●	○	—	—	—			

Note 1) Lead wire length symbol 0.5m ..... Nil (Example) A80C  
3m ..... L (Example) A80CL  
5m ..... Z (Example) A80CZ  
None ..... N (Example) A80CN

Note 2) Solid state auto switches marked with a "○" are produced upon receipt of order.

Note 3) Type D-F7LF cannot be mounted on bore size ø10.

# Series REAS



## Specifications

Fluid	Air
Proof pressure	1.05MPa
Maximum operating pressure	0.7MPa
Minimum operating pressure	0.18MPa
Ambient and fluid temperature	-10 to 60°C
Piston speed	50 to 300mm/s
Lubrication	Non-lube
Stroke length tolerance	0 to 250st: $^{+1.0}_0$ , 251 to 1000st: $^{+1.4}_0$ , 1001st and up: $^{+1.8}_0$

## Standard Strokes

Bore size (mm)	Standard stroke (mm)	Maximum manufacturable stroke (mm)
10	150, 200, 250, 300	500
15	150, 200, 250, 300, 350, 400 450, 500	750
20	200, 250, 300, 350, 400, 450 500, 600, 700, 800	1000
25		1500
32		1500
40	200, 250, 300, 350, 400, 450 500, 600, 700, 800, 900, 1000	1500

Note) Intermediate strokes can be arranged in 1mm increments.

## Magnetic Holding Force

Bore size (mm)	10	15	20	25	32	40
<b>Holding force</b>	53.9	137	231	363	588	922

(N)

## Weights

Bore size (mm)	10	15	20	25	32	40
<b>Basic weight</b>	0.48	0.91	1.48	1.84	3.63	4.02
<b>Additional weight per 50mm stroke</b>	0.074	0.104	0.138	0.172	0.267	0.406

(kg)

Calculation method/Example: REAS32-500

Basic weight ..... 3.63kg Additional weight ..... 0.267/50mm Cylinder stroke ... 500mm  
 $3.63 + 0.267 \times 500 \div 50 = 6.3\text{kg}$



 **Specific Product Precautions**

Be sure to read before handling. Refer to pages 92 through 94 for safety instructions and actuator precautions.

**Operation**

 **Warning**

- 1. Be aware of the space between the plates and the slide block.**

Take sufficient care as fingers and hands, etc., may be injured if caught while the cylinder is in operation.

- 2. Do not apply a load to a cylinder, which is greater than the allowable value stated in the "model selection pages".**

**Mounting**

 **Caution**

- 1. Avoid operation with the external slider fixed to the mounting surface.**

The cylinder should be operated with the plates fixed to the mounting surface.

- 2. Perform mounting so that the external slider will operate through the entire stroke at the minimum operating pressure.**

If the mounting surface is not flat, the guides will be warped, increasing the minimum operating pressure and causing premature wear of the bearings. Therefore, mounting should be performed so that the external slider will operate through the entire stroke at the minimum operating pressure. A mounting surface with a high degree of flatness is desirable, but in cases where this is not possible, adjust with shims, etc.

# Series REAS Model Selection 1

Pv: Maximum operating pressure for vertical operation (MPa)  
 WA: Allowable load weight based on these operating conditions (kg)  
 Wv: Allowable load weight for vertical operation (kg)  
 σ: Stroke coefficient

$$\sigma = \frac{\text{Load weight within stroke}}{\text{Max. load weight}}$$

- Operating conditions**
- W: Load weight (kg)
  - U: Maximum speed (mm/s)
  - P: Operating pressure (MPa)
  - Stroke (mm)
  - L<sub>o</sub>: Distance from slide block mounting surface to work piece center of gravity (cm)
  - Mode of operation (horizontal, inclined, vertical)

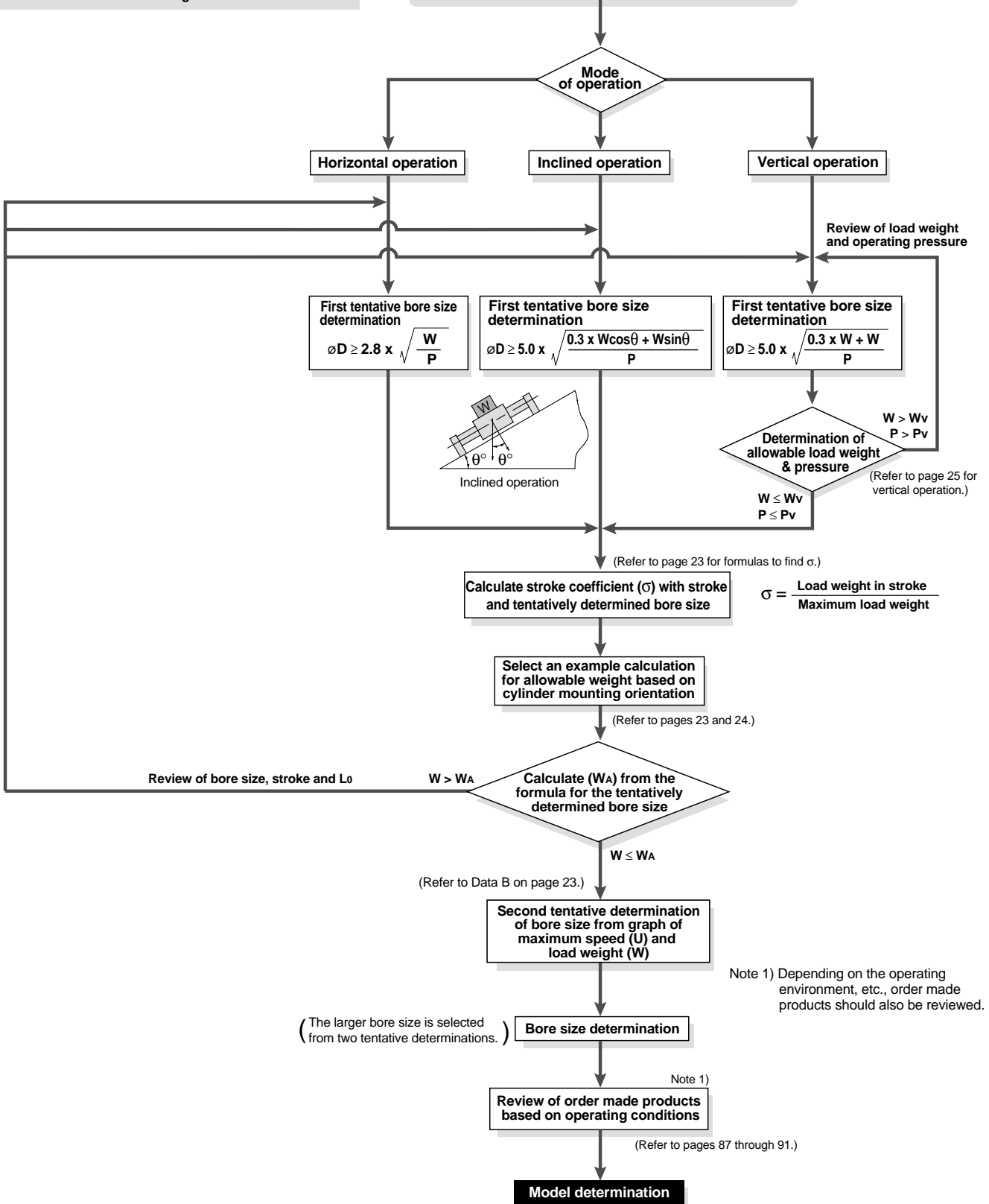

Note 1) Depending on the operating environment, etc., order made products should also be reviewed.

# Series REAS Model Selection 2

Max. Speed  
300  
mm/s

Basic Type  
REA

Direct Mount Type  
REAR

Slider Type/Slide Bearing  
REAS

Slider Type/Ball Bushing  
REAL

High Precision Guide Type  
REAH

Max. Speed  
600  
mm/s

Direct Mount Type  
REBR

High Precision Guide Type  
REBH

Auto Switches

Order Made

## Design Parameters 1

### How to Find $\sigma$ when Selecting the Allowable Load Weight

Since the maximum load weight with respect to the cylinder stroke changes as shown in the table below,  $\sigma$  should be considered as a coefficient determined in accordance with each stroke.

Example) for REAS25-650

- (1) Maximum load weight = 20kg
- (2) Load weight for 650st = 13.6kg
- (3)  $\sigma = \frac{13.6}{20} = 0.68$  is the result.

### Calculation formula for $\sigma$ ( $\sigma \leq 1$ )

ST: Stroke (mm)

Model	REAS10	REAS15	REAS20
$\sigma =$	$\frac{10^{(0.86 - 1.3 \times 10^{-3} \times ST)}}{3}$	$\frac{10^{(1.5 - 1.3 \times 10^{-3} \times ST)}}{7}$	$\frac{10^{(1.71 - 1.3 \times 10^{-3} \times ST)}}{12}$
Model	REAS25	REAS32	REAS40
$\sigma =$	$\frac{10^{(1.98 - 1.3 \times 10^{-3} \times ST)}}{20}$	$\frac{10^{(2.26 - 1.3 \times 10^{-3} \times ST)}}{30}$	$\frac{10^{(2.48 - 1.3 \times 10^{-3} \times ST)}}{50}$

Note) Calculate with  $\sigma = 1$  for all applications up to  $\phi 10$ -300mmST,  $\phi 15$ -500mmST,  $\phi 20$ -500mmST,  $\phi 25$ -500mmST,  $\phi 32$ -600mmST and  $\phi 40$ -600mmST.

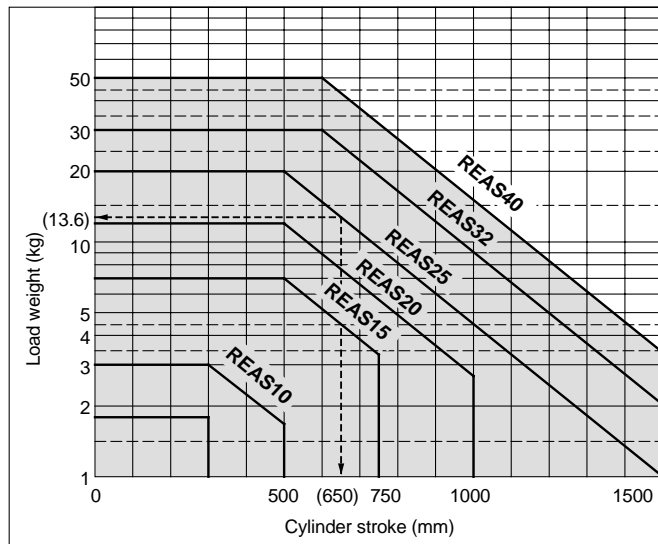

### <Data (B): Maximum speed — Load weight chart>

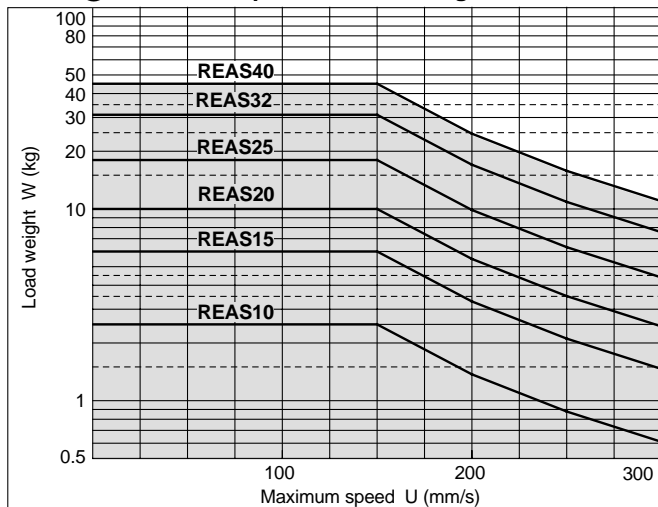

### Examples of Allowable Load Weight Calculation Based on Cylinder Mounting Orientation

#### 1. Horizontal operation (floor mounting)

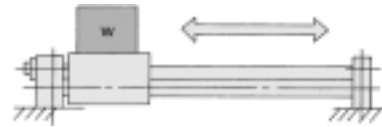

Maximum load weight (center of slide block)

(kg)

Bore size (mm)	10	15	20	25	32	40
Max. load weight (kg)	3	7	12	20	30	50
Stroke (max)	to 300st	to 500st	to 500st	to 500st	to 600st	to 600st

The above maximum load weight values will change with the stroke length for each cylinder size, due to limitation from warping of the guide shafts. (Take note of the coefficient  $\sigma$ .) Moreover, depending on the operating direction, the allowable load weight may be different from the maximum load weight.

#### 2. Horizontal operation (wall mounting)

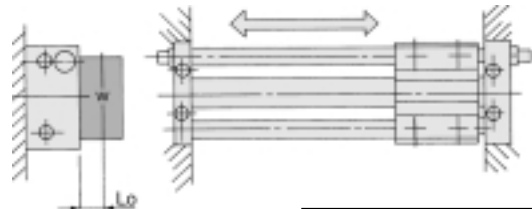

Lo: Distance from mounting surface to load center of gravity (cm)

Bore size (mm)	Allowable load weight $W_A$ (kg)
10	$\sigma \cdot 12.0$ $8.4 + 2L_o$
15	$\sigma \cdot 36.4$ $10.6 + 2L_o$
20	$\sigma \cdot 74.4$ $12 + 2L_o$
25	$\sigma \cdot 140$ $13.8 + 2L_o$
32	$\sigma \cdot 258$ $17 + 2L_o$
40	$\sigma \cdot 520$ $20.6 + 2L_o$

#### 3. Vertical operation

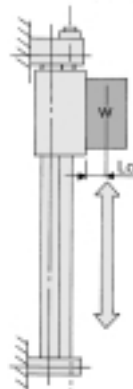

Bore size (mm)	Allowable load weight $W_A$ (kg)
10	$\sigma \cdot 4.16$ $2.2 + L_o$
15	$\sigma \cdot 13.23$ $2.7 + L_o$
20	$\sigma \cdot 26.8$ $2.9 + L_o$
25	$\sigma \cdot 44.0$ $3.4 + L_o$
32	$\sigma \cdot 88.2$ $4.2 + L_o$
40	$\sigma \cdot 167.8$ $5.1 + L_o$

Lo: Distance from mounting surface to load center of gravity (cm)  
Note) A safety factor should be considered to prevent dropping.

# Series REAS Model Selection 3

## Design Parameters 2

### Examples of Allowable Load Weight Calculation Based on Cylinder Mounting Orientation

#### 4. Inclined operation (in operating direction)

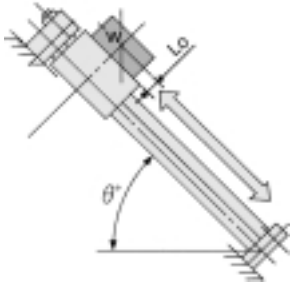

Angle	to 45°	to 60°	to 75°	to 90°
k	1	0.9	0.8	0.7

Angle coefficient (k): k = [to 45° (= θ)] = 1,  
[to 60°] = 0.9,  
[to 75°] = 0.8,  
[to 90°] = 0.7

Lo: Distance from mounting surface to load center of gravity (cm)

Bore size (mm)	Allowable load weight WA (kg)
10	$\frac{\sigma \cdot 10.5 \cdot K}{3.5 \cos \theta + 2 (2.2 + Lo) \sin \theta}$
15	$\frac{\sigma \cdot 35 \cdot K}{5 \cos \theta + 2 (2.7 + Lo) \sin \theta}$
20	$\frac{\sigma \cdot 72 \cdot K}{6 \cos \theta + 2 (2.9 + Lo) \sin \theta}$
25	$\frac{\sigma \cdot 120 \cdot K}{6 \cos \theta + 2 (3.4 + Lo) \sin \theta}$
32	$\frac{\sigma \cdot 210 \cdot K}{7 \cos \theta + 2 (4.2 + Lo) \sin \theta}$
40	$\frac{\sigma \cdot 400 \cdot K}{8 \cos \theta + 2 (5.1 + Lo) \sin \theta}$

#### 5. Inclined operation (at a right angle to operating direction)

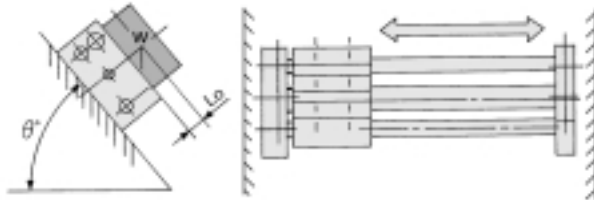

Lo: Distance from mounting surface to load center of gravity (cm)

Bore size (mm)	Allowable load weight WA (kg)
10	$\frac{\sigma \cdot 12.0}{4 + 2 (2.2 + Lo) \sin \theta}$
15	$\frac{\sigma \cdot 36.4}{5.2 + 2 (2.7 + Lo) \sin \theta}$
20	$\frac{\sigma \cdot 74.4}{6.2 + 2 (2.9 + Lo) \sin \theta}$
25	$\frac{\sigma \cdot 140}{7 + 2 (3.4 + Lo) \sin \theta}$
32	$\frac{\sigma \cdot 258}{8.6 + 2 (4.2 + Lo) \sin \theta}$
40	$\frac{\sigma \cdot 520}{10.4 + 2 (5.1 + Lo) \sin \theta}$

#### 6. Load center offset in operating direction (Lo)

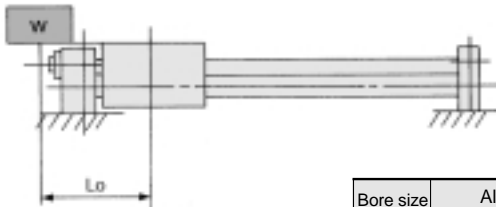

Lo: Distance from slide block center to load center of gravity (cm)

Bore size (mm)	Allowable load weight WA (kg)
10	$\frac{\sigma \cdot 5.25}{Lo + 3.5}$
15	$\frac{\sigma \cdot 17.5}{Lo + 5.0}$
20	$\frac{\sigma \cdot 36}{Lo + 6.0}$
25	$\frac{\sigma \cdot 60}{Lo + 6.0}$
32	$\frac{\sigma \cdot 105}{Lo + 7.0}$
40	$\frac{\sigma \cdot 200}{Lo + 8.0}$

#### 7. Horizontal operation (pushing load, pusher)

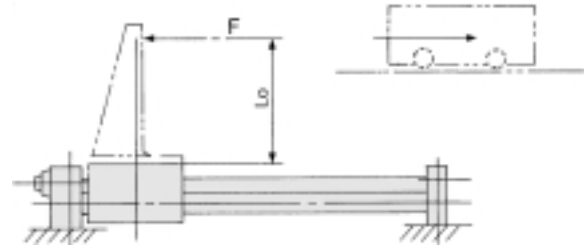

F: Drive (from slide block to position Lo) resistance force (kg)  
Lo: Distance from mounting surface to load center of gravity (cm)

Bore size (mm)	10	15	20
Allowable load weight WA (kg)	$\frac{\sigma \cdot 5.25}{2.2 + Lo}$	$\frac{\sigma \cdot 17.5}{2.7 + Lo}$	$\frac{\sigma \cdot 36}{2.9 + Lo}$
Bore size (mm)	25	32	40
Allowable load weight WA (kg)	$\frac{\sigma \cdot 60}{3.4 + Lo}$	$\frac{\sigma \cdot 105}{4.2 + Lo}$	$\frac{\sigma \cdot 200}{5.1 + Lo}$

#### 8. Horizontal operation (load, lateral offset Lo)

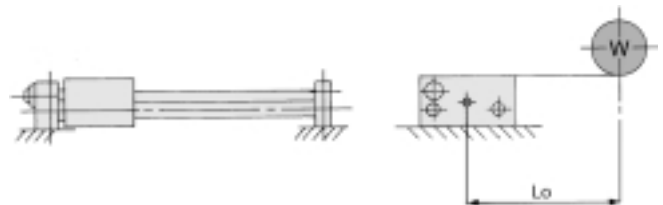

Lo: Distance from mounting surface to load center of gravity (cm)

Bore size (mm)	10	15	20
Allowable load weight WA (kg)	$\frac{\sigma \cdot 8.40}{4 + Lo}$	$\frac{\sigma \cdot 25.48}{5.2 + Lo}$	$\frac{\sigma \cdot 52.1}{6.2 + Lo}$
Bore size (mm)	25	32	40
Allowable load weight WA (kg)	$\frac{\sigma \cdot 98}{7.0 + Lo}$	$\frac{\sigma \cdot 180}{8.6 + Lo}$	$\frac{\sigma \cdot 364}{10.4 + Lo}$

# Series REAS Model Selection 4

## Design Parameters 3

### Vertical Operation

When operating a load vertically, it should be operated within the allowable load weights and maximum operating pressures shown in the table below. Use caution, as operating above the prescribed values may lead to dropping of the load.

Bore size (mm)	Model	Allowable load weight Wv (kg)	Max. operating pressure Pv (MPa)
10	REAS10	2.7	0.55
15	REAS15	7.0	0.65
20	REAS20	11.0	0.65
25	REAS25	18.5	0.65
32	REAS32	30.0	0.65
40	REAS40	47.0	0.65

Note) Use caution, as there is a possibility of breaking the magnetic coupling if operated above the maximum operating pressure.

### Stroke Adjustment

The adjustment bolt is adjusted to the optimum position for smooth acceleration and deceleration at the time of shipment, and should be operated at the full stroke. When stroke adjustment is necessary, the maximum amount of adjustment on one side is 2mm. (Do not adjust more than 2mm, as it will not be possible to obtain smooth acceleration and deceleration.)

#### Stroke Adjustment

Loosen the hexagon nut, and after performing the stroke adjustment from the plate side with a hexagon wrench, retighten and secure the hexagon nut.

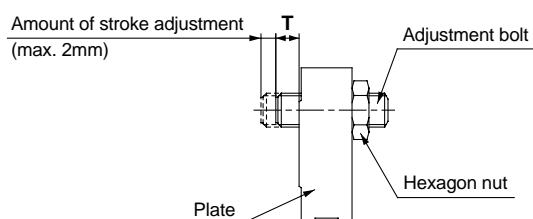

### Adjustment Bolt Position (at Shipment), Hexagon Nut Tightening Torque

Model	T (mm)	Tightening torque (N·m)
REAS10	1	1.67
REAS15	1	
REAS20	1.5	3.14
REAS25	1.5	10.8
REAS32	3	23.5
REAS40	2	

### Intermediate Stops

The cushion effect (smooth start-up, soft stop) exists only before the stroke end in the stroke ranges indicated in the table below.

The cushion effect (smooth start-up, soft stop) cannot be obtained in an intermediate stop or a return from an intermediate stop using an external stopper, etc.

#### Cushion stroke

Model	Stroke (mm)
REAS10	20
REAS15	25
REAS20	30
REAS25	30
REAS32	30
REAS40	35

Max. Speed  
300  
mm/s

Basic Type  
REA

Direct Mount Type  
REAR

Slider Type/Slider Bearing  
REAS

Slider Type/Ball Bushing  
REAL

High Precision Guide Type  
REAH

Max. Speed  
600  
mm/s

Direct Mount Type  
REBR

High Precision Guide Type  
REBH

Auto Switches

Order Made

# Series REAS

Construction/ø10, ø15

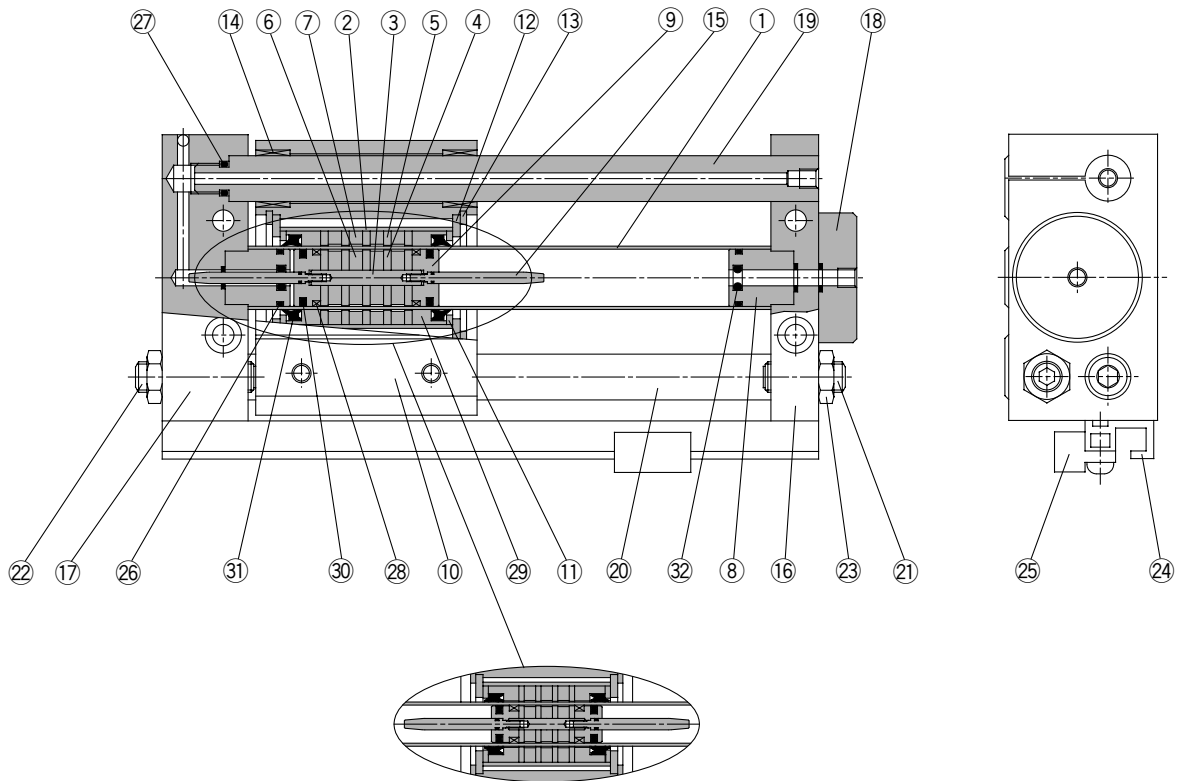

**REAS10**

## Parts list

No.	Description	Material	Note
1	Cylinder tube	Stainless steel	
2	External slider tube	Aluminum alloy	
3	Shaft	Stainless steel	
4	Piston side yoke	Rolled steel plate	Zinc chromated
5	External slider side yoke	Rolled steel plate	Zinc chromated
6	Magnet A	Rare earth magnet	
7	Magnet B	Rare earth magnet	
8	Cushion seal holder	Aluminum alloy	Anodized
9	Piston	Brass	Electroless nickel plated
10	Slide block	Aluminum alloy	Hard anodized
11	Spacer	Rolled steel plate	Nickel plated
12	Slider spacer	Rolled steel plate	Nickel plated
13	Snap ring	Carbon tool steel	Nickel plated
14	Bushing	Oil retaining bearing material	
15	Cushion ring	Stainless steel	
16	Plate A	Aluminum alloy	Hard anodized

## Parts list

No.	Description	Material	Note
17	Plate B	Aluminum alloy	Hard anodized
18	Port cover	Aluminum alloy	Hard anodized
19	Guide shaft A	Carbon steel	Hard chrome plated
20	Guide shaft B	Carbon steel	Hard chrome plated
21	Adjustment bolt A	Chromium molybdenum steel	Nickel plated
22	Adjustment bolt B	Chromium molybdenum steel	Nickel plated
23	Hexagon nut	Carbon steel	Nickel plated
24	Switch mounting rail	Aluminum alloy	
25	Auto switch	-	
26*	Cylinder tube gasket	NBR	
27*	Guide shaft gasket	NBR	
28*	Wear ring A	Special resin	
29*	Wear ring B	Special resin	
30*	Piston seal	NBR	
31*	Scraper	NBR	
32*	Cushion seal	NBR	

\* Seal kits are sets consisting of items 26 through 32 above, and can be ordered using the kit number for each bore size.

## Replacement parts: Seal kits

Bore size (mm)	Kit no.	Contents
10	REAS10-PS	Above numbers 26, 27, 28, 29, 30, 31, 32
15	REAS15-PS	

## Construction/ø20 to ø40

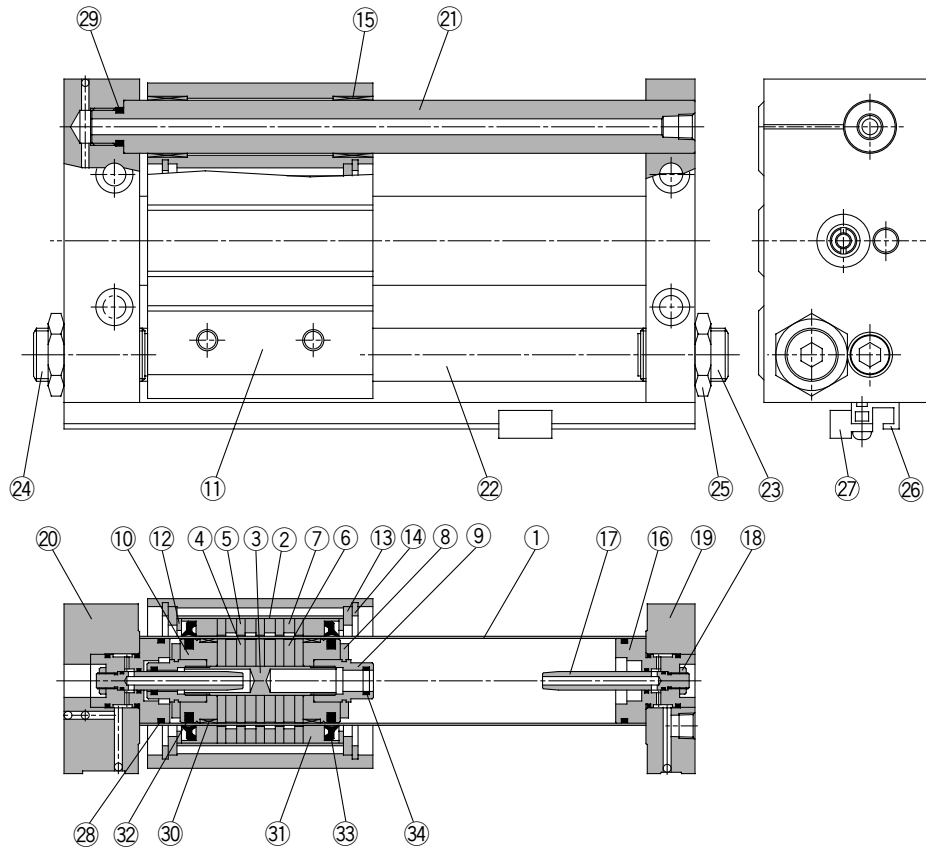

### Parts list

No.	Description	Material	Note
1	Cylinder tube	Stainless steel	
2	External slider tube	Aluminum alloy	
3	Shaft	Stainless steel	
4	Piston side yoke	Rolled steel plate	Zinc chromated
5	External slider side yoke	Rolled steel plate	Zinc chromated
6	Magnet A	Rare earth magnet	
7	Magnet B	Rare earth magnet	
8	Bumper	Urethane rubber	
9	Cushion seal holder	Aluminum alloy	Chromated
10	Piston	Aluminum alloy	Chromated
11	Slide block	Aluminum alloy	Hard anodized
12	Spacer	Rolled steel plate	Nickel plated
13	Slider spacer	Rolled steel plate	Nickel plated
14	Snap ring	Carbon tool steel	Nickel plated
15	Bushing	Oil retaining bearing material	
16	Cushion ring holder	Aluminum alloy	Anodized
17	Cushion ring	Brass	Electroless nickel plated (REAS32, 40)
		Stainless steel	REAS20, 25

### Parts list

No.	Description	Material	Note
18	Lock nut B	Carbon steel	Nickel plated
19	Plate A	Aluminum alloy	Hard anodized
20	Plate B	Aluminum alloy	Hard anodized
21	Guide shaft A	Carbon steel	Hard chrome plated
22	Guide shaft B	Carbon steel	Hard chrome plated
23	Adjustment bolt A	Chromium molybdenum steel	Nickel plated
24	Adjustment bolt B	Chromium molybdenum steel	Nickel plated
25	Hexagon nut	Carbon steel	Nickel plated
26	Switch mounting rail	Aluminum alloy	
27	Auto switch	-	When equipped with auto switch
28*	Cylinder tube gasket	NBR	
29*	Guide shaft gasket	NBR	
30*	Wear ring A	Special resin	
31*	Wear ring B	Special resin	
32*	Piston seal	NBR	
33*	Scraper	NBR	
34*	Cushion seal	NBR	

\* Seal kits are sets consisting of items 28 through 34 above, and can be ordered using the kit number for each bore size.

### Replacement parts: Seal kits

Bore size (mm)	Kit no.	Contents
20	REAS20-PS	Above numbers 28, 29, 30, 31, 32, 33, 34
25	REAS25-PS	
32	REAS32-PS	
40	REAS40-PS	

# Series REAS

## Dimensions/ø10

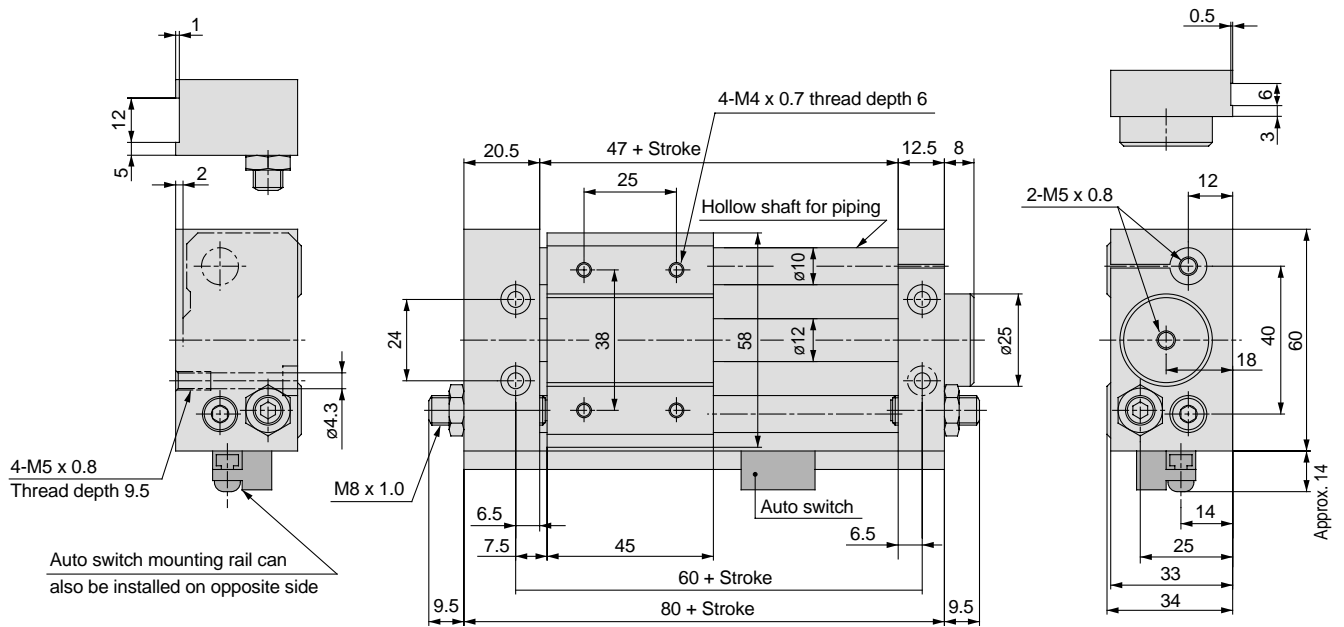



**Dimensions/ø15 to ø40**

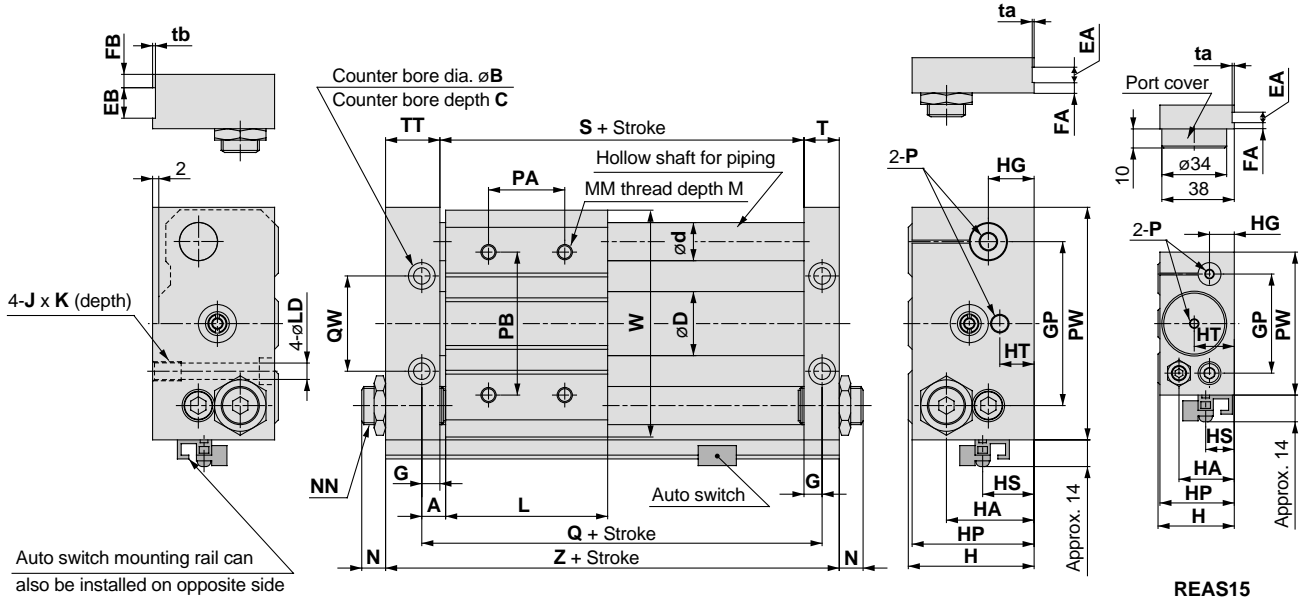

Model	A	B	C	D	d	EA	EB	FA	FB	G	GP	H	HA	HG
REAS15	7.5	9.5	5	16.6	12	6	13	3	6	6.5	52	40	29	13
REAS20	10	9.5	5	21.6	16	—	—	—	—	8.5	62	46	36	17
REAS25	10	11	6.5	26.4	16	8	14	4	7	8.5	70	54	40	20
REAS32	12.5	14	8	33.6	20	8	16	5	7	9.5	86	66	46	24
REAS40	12.5	14	8	41.6	25	10	20	5	10	10.5	104	76	57	25

Model	HP	HS	HT	J x K	L	LD	M	MM	N	NN
REAS15	39	15	21	M6 x 1.0 x 9.5	60	5.6	8	M5 x 0.8	7.5	M8 x 1.0
REAS20	45	25.5	10	M6 x 1.0 x 9.5	70	5.6	10	M6 x 1.0	9.5	M10 x 1.0
REAS25	53	23	10	M8 x 1.25 x 10	70	7	10	M6 x 1.0	11	M14 x 1.5
REAS32	64	27	17	M10 x 1.5 x 15	85	8.7	12	M8 x 1.25	11.5	M20 x 1.5
REAS40	74	31	14	M10 x 1.5 x 15	95	8.7	12	M8 x 1.25	10.5	M20 x 1.5

Model	P	PA*	PB	PW	Q	QW	S	T	TT	ta	tb	W	Z
REAS15	M5 x 0.8	30	50	75	75	30	62	12.5	22.5	0.5	1	72	97
REAS20	Rc 1/8	40	70	90	90	38	73	16.5	25.5	—	—	87	115
REAS25	Rc 1/8	40	70	100	90	42	73	16.5	25.5	0.5	1	97	115
REAS32	Rc 1/8	40	75	122	110	50	91	18.5	28.5	0.5	1	119	138
REAS40	Rc 1/4	65	105	145	120	64	99	20.5	35.5	1	1	142	155

\* PA dimensions are for split from center.

Max. Speed  
300  
mm/s

Basic Type  
REA

Direct Mount Type  
REAR

Slider Type/Slide Bearing  
REAS

Slider Type/Ball Bushing  
REAL

High Precision Guide Type  
REAH

Max. Speed  
600  
mm/s

Direct Mount Type  
REBR

High Precision Guide Type  
REBH

Auto Switches

Order Made

# Series REAS

## Proper Auto Switch Mounting Position for Stroke End Detection

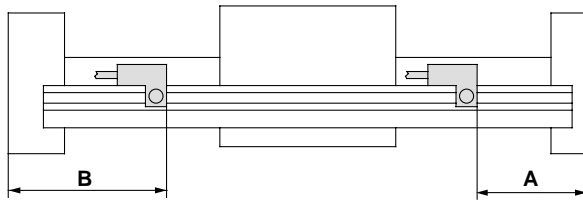

## Auto Switch Operating Range

(mm)

Auto switch model	Bore size (mm)		
	D-A7□/A80 D-A7□H/A80H D-A73C/A80C	D-F7□/J79 D-J79C D-F7□V D-F7NTL D-F7□W/J79W D-F7□WV D-F7BAL	D-F7LF D-F79F
10	6	3	4.5
15	6	4	4.5
20	6	3	4.5
25	6	3	4.5
32	6	3	4.5
40	6	3.5	4.5

Note) Operating ranges are standards including hysteresis, and are not guaranteed. Large variations may occur depending on the surrounding environment. (variations on the order of  $\pm 30\%$ )

(mm)

Auto switch model	Dimension A				Dimension B			
	D-A73/A80	D-A72 D-A7□H/A80H D-A73C/A80C D-F7□/J79 D-J79C D-F7□V	D-F7□W/J79W D-F7□WV D-F7LF (Note 1) D-F79F D-F7BAL	D-F7NTL	D-A73/A80	D-A72 D-A7□H/A80H D-A73C/A80C D-F7□/J79 D-J79C D-F7□V	D-F7□W/J79W D-F7□WV D-F7LF (Note 1) D-F79F D-F7BAL	D-F7NTL
10	35	35.5	39.5	40.5	45	44.5	40.5	39.5
15	34.5	35	39	40	62.5	62	58	57
20	64	64.5	68.5	69.5	50	49.5	45.5	44.5
25	44	44.5	48.5	49.5	71	70.5	66.5	65.5
32	55	55.5	59.5	59.5	83	82.5	78.5	77.5
40	61	61.5	65.5	65.5	94	93.5	89.5	88.5

Note1 ) Model D-F7LF cannot be mounted on bore size  $\phi 10$ .

## Auto Switch Mounting

When mounting an auto switch, the switch mounting screw should be screwed into a hexagon nut (M3 x 0.5) which has been inserted into the groove of the switch rail. (The tightening torque should be about 0.05 to 0.1N·m.)

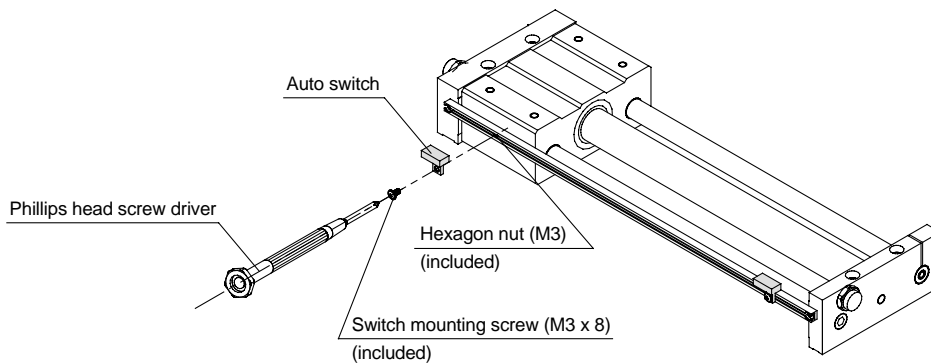

# Series REAL Slider Type/Ball Bushing

## How to Order

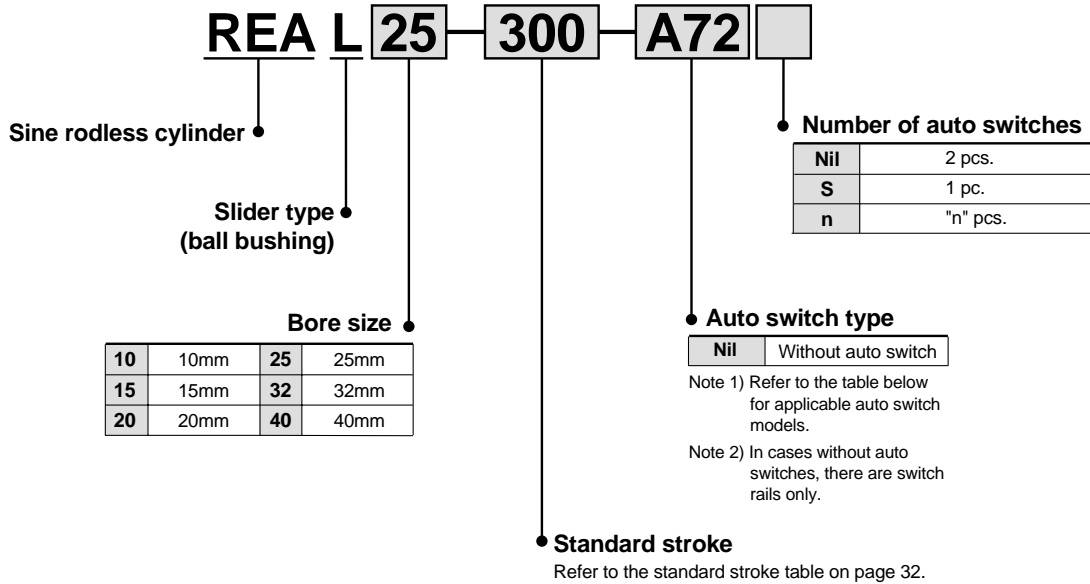

**Applicable auto switches** / Refer to "Auto Switch Guide" (E-274-A) for further details on auto switch units. Refer to pages 84 and 85 for auto switch circuit diagrams.

Type	Special function	Electrical entry	Indicator light	Wiring (output)	Load voltage		Auto switch model		Lead wire length (m) <sup>Note 1)</sup>				Applicable load									
					DC	AC	Electrical entry direction		0.5 (Nil)	3 (L)	5 (Z)	None (N)										
							Perpendicular	In-line														
Reed switches	—	Grommet	Yes	3 wire (NPN equiv.)	—	5V	—	—	A76H	●	●	—	—	IC circuit	—							
										24V	—	200V	A72			A72H	●	●	—	—		
													12V			100V	A73	A73H	●	●	●	—
													5V, 12V			100V or less	A80	A80H	●	●	—	—
																	A73C	—	●	●	●	●
Connector	Yes	24V or less	A80C	—	●	●	●	●														
			No	5V, 12V	24V or less	—	—	●	●	●	●											
Solid state switches	—	Grommet	Yes	3 wire (NPN)	24V	5V, 12V	—	F7NV	F79	●	●	○	—	IC circuit	Relay, PLC							
				3 wire (PNP)				F7PV	F7P	●	●	○	—									
				2 wire				F7BV	J79	●	●	○	—									
		Connector		Yes				24V	J79C	—	●	●	●			●						
									5V, 12V	—	—	●	●			○	—					
		Diagnostic indication (2 color indicator)		Grommet				Yes	24V	F7NWV	F79W	●	●			○	—					
	—		F7PW		●	●	○			—												
	Water resistant (2 color indicator)	Grommet	Yes	24V	F7BWV	J79W	●	●	○	—												
	With timer				—	F7BA	—	●	○	—												
	With diagnostic output (2 color indicator)	Grommet	Yes	24V	—	F7NT	—	●	○	—												
	Latch type with diagnostic output (2 color indicator)				—	F79F	●	●	○	—												
	—	—	—	—	—	—	—	—	—	—	—	—	—	—	—							
	—	—	—	—	—	—	—	—	—	—	—	—	—	—	—	—						
—	—	—	—	—	—	—	—	—	—	—	—	—	—	—	—							
—	—	—	—	—	—	—	—	—	—	—	—	—	—	—	—							
—	—	—	—	—	—	—	—	—	—	—	—	—	—	—	—							
—	—	—	—	—	—	—	—	—	—	—	—	—	—	—	—							

Note 1) Lead wire length symbol 0.5m ..... Nil (Example) A80C  
3m ..... L (Example) A80CL  
5m ..... Z (Example) A80CZ  
None ..... N (Example) A80CN

Note 2) Solid state auto switches marked with a "○" are produced upon receipt of order.

Note 3) Type D-F7LF cannot be mounted on bore size ø10.

# Series REAL



## Specifications

Fluid	Air
Proof pressure	1.05MPa
Maximum operating pressure	0.7MPa
Minimum operating pressure	0.18MPa
Ambient and fluid temperature	-10 to 60°C
Piston speed	50 to 300mm/s
Lubrication	Non-lube
Stroke length tolerance	0 to 250st: $^{+1.0}_0$ , 251 to 1000st: $^{+1.4}_0$ , 1001st and up: $^{+1.8}_0$

## Standard Strokes

Bore size (mm)	Standard stroke (mm)	Maximum manufacturable stroke (mm)
10	150, 200, 250, 300	500
15	150, 200, 250, 300, 350, 400, 450, 500	750
20	200, 250, 300, 350, 400, 450, 500, 600, 700, 800	1000
25		1500
32		1500
40	200, 250, 300, 350, 400, 450, 500, 600, 700, 800, 900, 1000	1500

Note) Intermediate strokes can be arranged in 1mm increments.

## Magnetic Holding Force

Bore size (mm)	10	15	20	25	32	40
Holding force	53.9	137	231	363	588	922

(N)

## Weights

Bore size (mm)	10	15	20	25	32	40
Basic weight	0.58	1.10	1.85	2.21	4.36	4.83
Additional weight per 50mm stroke	0.077	0.104	0.138	0.172	0.267	0.406

(kg)

Calculation method/Example: REALS32-500

Basic weight ..... 4.36kg Additional weight ..... 0.267/50mm Cylinder stroke ... 500mm  
 $4.36 + 0.267 \times 500 \div 50 = 7.03\text{kg}$

 **Specific Product Precautions**

Be sure to read before handling. Refer to pages 92 through 94 for safety instructions and actuator precautions.

**Operation**

 **Warning**

- 1. Be aware of the space between the plates and the slide block.**  
Take sufficient care as fingers and hands, etc., may be injured if caught while the cylinder is in operation.
- 2. Do not apply a load to a cylinder which is greater than the allowable value stated in the "model selection pages".**

**Mounting**

 **Caution**

- 1. Avoid operation with the external slider fixed to the mounting surface.**  
The cylinder should be operated with the plates fixed to the mounting surface.
- 2. Perform mounting so that the external slider will operate through the entire stroke at the minimum operating pressure.**  
If the mounting surface is not flat, the guides will be warped, increasing the minimum operating pressure and causing premature wear of the bearings. Therefore, mounting should be performed so that the external slider will operate through the entire stroke at the minimum operating pressure. A mounting surface with a high degree of flatness is desirable, but in cases where this is not possible, adjust with shims, etc.

# Series REAL Model Selection 1

Pv: Maximum operating pressure for vertical operation (MPa)  
 WA: Allowable load weight based on these operating conditions (kg)  
 Wv: Allowable load weight for vertical operation (kg)  
 σ: Stroke coefficient

$$\sigma = \frac{\text{Load weight within stroke}}{\text{Max. load weight}}$$

- Operating conditions**
- W: Load weight (kg)
  - U: Maximum speed (mm/s)
  - P: Operating pressure (MPa)
  - Stroke (mm)
  - L<sub>0</sub>: Distance from slide block mounting surface to work piece center of gravity (cm)
  - Mode of operation (horizontal, inclined, vertical)

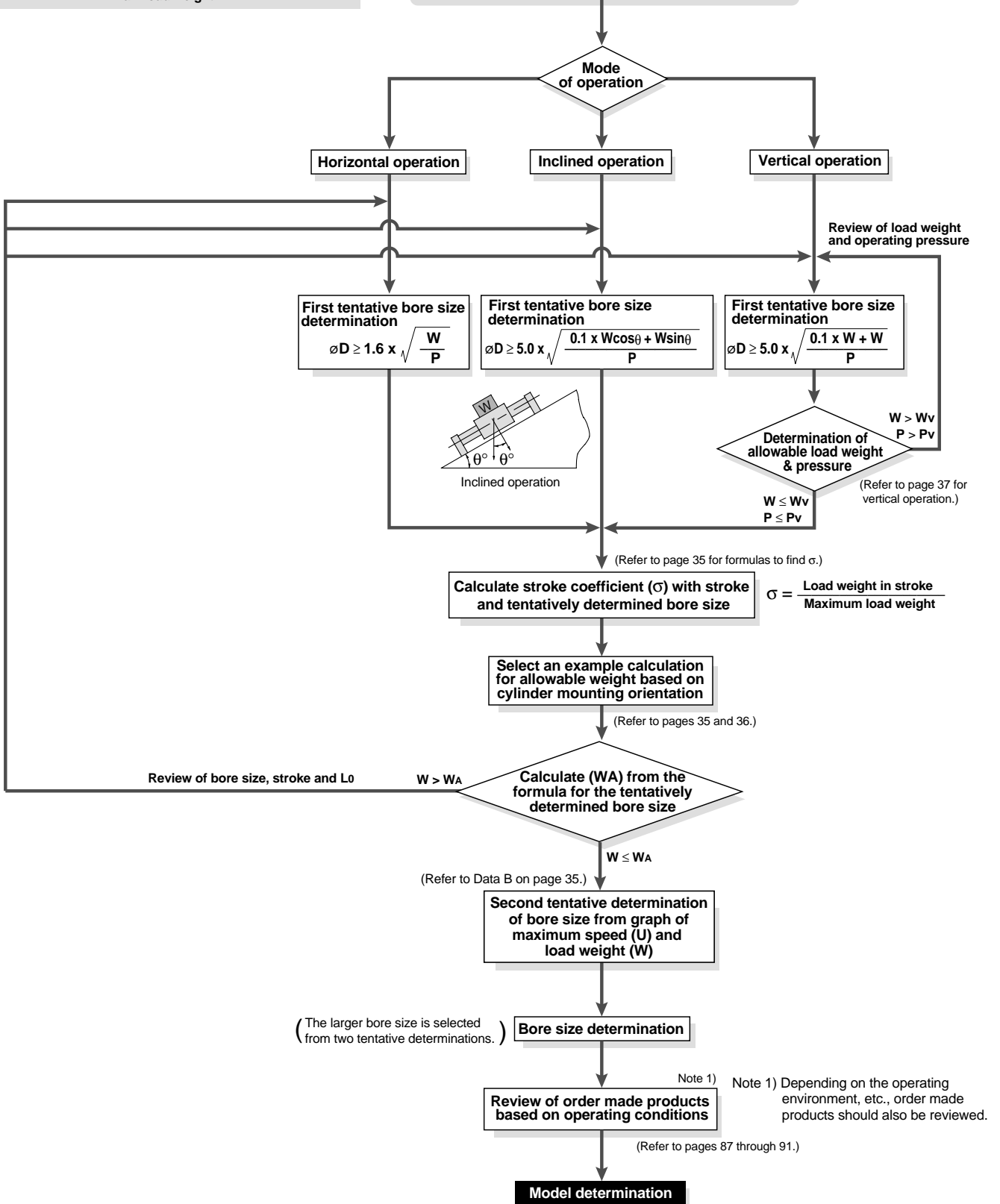

# Series REAL Model Selection 2

Max. Speed  
300  
mm/s

Basic Type  
REAL

Direct Mount Type  
REAR

Slider Type/Slide Bearing  
REAS

Slider Type/Ball Bushing  
REAL

High Precision Guide Type  
REAH

Max. Speed  
600  
mm/s

Direct Mount Type  
REBR

High Precision Guide Type  
REBH

Auto Switches

Order Made

## Design Parameters 1

### How to Find $\sigma$ when Selecting the Allowable Load Weight

Since the maximum load weight with respect to the cylinder stroke changes as shown in the table below,  $\sigma$  should be considered as a coefficient determined in accordance with each stroke.

Example) for REAL25-650

- (1) Maximum load weight = 20kg
- (2) Load weight for 650st = 13.6kg
- (3)  $\sigma = \frac{13.6}{20} = 0.68$  is the result.

### Calculation formula for $\sigma$ ( $\sigma \leq 1$ )

ST: Stroke (mm)

Model	REAL10	REAL15	REAL20
$\sigma =$	$\frac{10^{(0.86 - 1.3 \times 10^{-3} \times ST)}}{3}$	$\frac{10^{(1.5 - 1.3 \times 10^{-3} \times ST)}}{7}$	$\frac{10^{(1.71 - 1.3 \times 10^{-3} \times ST)}}{12}$

Model	REAL25	REAL32	REAL40
$\sigma =$	$\frac{10^{(1.98 - 1.3 \times 10^{-3} \times ST)}}{20}$	$\frac{10^{(2.26 - 1.3 \times 10^{-3} \times ST)}}{30}$	$\frac{10^{(2.48 - 1.3 \times 10^{-3} \times ST)}}{50}$

Note) Calculate with  $\sigma = 1$  for all applications up to  $\phi 10-300$ mmST,  $\phi 15-500$ mmST,  $\phi 20-500$ mmST,  $\phi 25-500$ mmST,  $\phi 32-600$ mmST and  $\phi 40-600$ mmST.

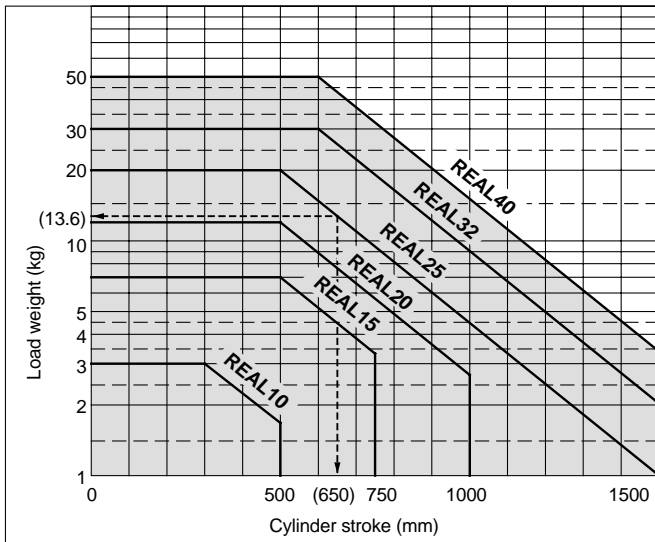

### <Data B: Maximum speed — Load weight chart>

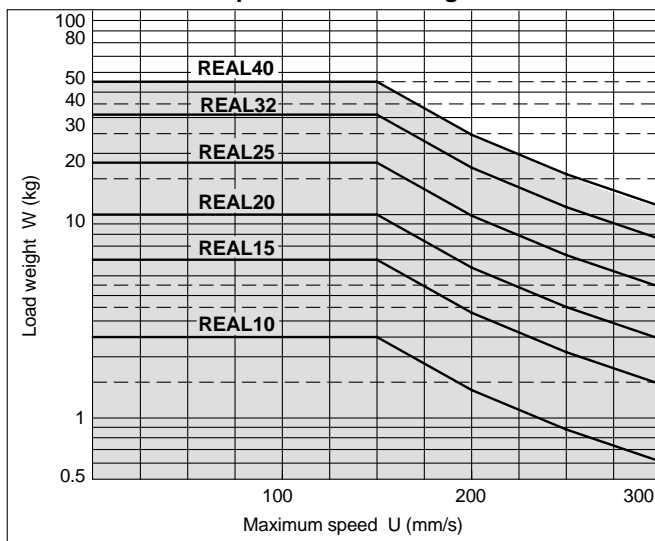

### Examples of Allowable Load Weight Calculation Based on Cylinder Mounting Orientation

#### 1. Horizontal operation (floor mounting)

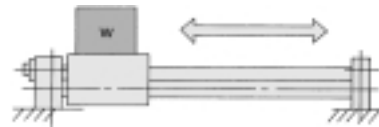

Maximum load weight (center of slide block) (kg)

Bore size (mm)	10	15	20	25	32	40
Max. load weight (kg)	3	7	12	20	30	50
Stroke (max)	to 300st	to 500st	to 500st	to 500st	to 600st	to 600st

The above maximum load weight values will change with the stroke length for each cylinder size, due to limitation from warping of the guide shafts. (Take note of the coefficient  $\sigma$ .) Moreover, depending on the operating direction, the allowable load weight may be different from the maximum load weight.

#### 2. Horizontal operation (wall mounting)

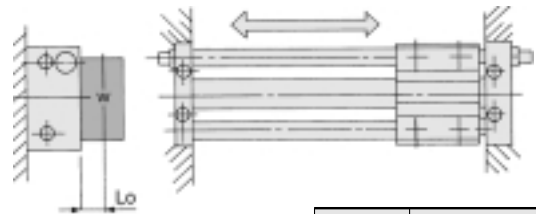

Lo: Distance from mounting surface to load center of gravity (cm)

Bore size (mm)	Allowable load weight WA (kg)
10	$\frac{\sigma \cdot 15.0}{8.9 + 2Lo}$
15	$\frac{\sigma \cdot 45.5}{11.3 + 2Lo}$
20	$\frac{\sigma \cdot 101}{13.6 + 2Lo}$
25	$\frac{\sigma \cdot 180}{15.2 + 2Lo}$
32	$\frac{\sigma \cdot 330}{18.9 + 2Lo}$
40	$\frac{\sigma \cdot 624}{22.5 + 2Lo}$

#### 3. Vertical operation

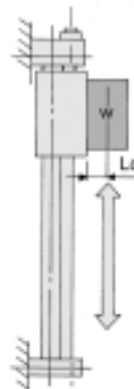

Lo: Distance from mounting surface to load center of gravity (cm)  
Note) A safety factor should be considered to prevent dropping.

Bore size (mm)	Allowable load weight WA (kg)
10	$\frac{\sigma \cdot 5.00}{1.95 + Lo}$
15	$\frac{\sigma \cdot 15.96}{2.4 + Lo}$
20	$\frac{\sigma \cdot 31.1}{2.8 + Lo}$
25	$\frac{\sigma \cdot 54.48}{3.1 + Lo}$
32	$\frac{\sigma \cdot 112.57}{3.95 + Lo}$
40	$\frac{\sigma \cdot 212.09}{4.75 + Lo}$

# Series REAL Model Selection 3

## Design Parameters 2

### Examples of Allowable Load Weight Calculation Based on Cylinder Mounting Orientation

#### 4. Inclined operation (in operating direction)

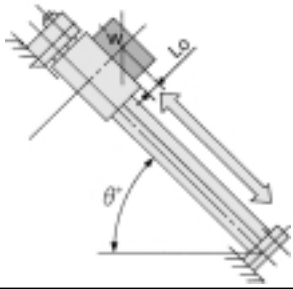

Angle	to 45°	to 60°	to 75°	to 90°
k	1	0.9	0.8	0.7

Angle coefficient (k): k = [to 45° (= θ)] = 1,  
[to 60°] = 0.9,  
[to 75°] = 0.8,  
[to 90°] = 0.7

Lo: Distance from mounting surface to load center of gravity (cm)

Bore size (mm)	Allowable load weight WA (kg)
10	$\frac{\sigma \cdot 10.2 \cdot K}{2.8 \cos \theta + 2(1.95 + Lo) \sin \theta}$
15	$\frac{\sigma \cdot 31.1 \cdot K}{2.9 \cos \theta + 2(2.4 + Lo) \sin \theta}$
20	$\frac{\sigma \cdot 86.4 \cdot K}{6 \cos \theta + 2(2.8 + Lo) \sin \theta}$
25	$\frac{\sigma \cdot 105.4 \cdot K}{3.55 \cos \theta + 2(3.1 + Lo) \sin \theta}$
32	$\frac{\sigma \cdot 178 \cdot K}{4 \cos \theta + 2(3.95 + Lo) \sin \theta}$
40	$\frac{\sigma \cdot 361.9 \cdot K}{5.7 \cos \theta + 2(4.75 + Lo) \sin \theta}$

#### 5. Inclined operation (at a right angle to operating direction)

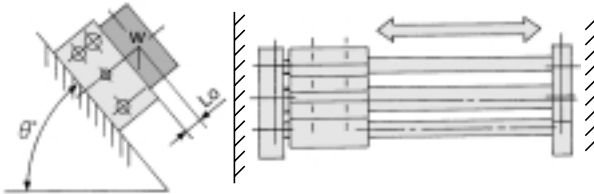

Lo: Distance from mounting surface to load center of gravity (cm)

Bore size (mm)	Allowable load weight WA (kg)
10	$\frac{\sigma \cdot 15}{5 + 2(1.95 + Lo) \sin \theta}$
15	$\frac{\sigma \cdot 45.5}{6.5 + 2(2.4 + Lo) \sin \theta}$
20	$\frac{\sigma \cdot 115}{8 + 2(2.8 + Lo) \sin \theta}$
25	$\frac{\sigma \cdot 180}{9 + 2(3.1 + Lo) \sin \theta}$
32	$\frac{\sigma \cdot 330}{11 + 2(3.95 + Lo) \sin \theta}$
40	$\frac{\sigma \cdot 624}{13 + 2(4.75 + Lo) \sin \theta}$

#### 6. Load center offset in operating direction (Lo)

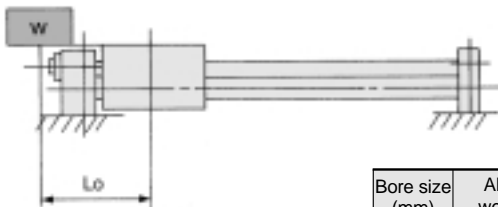

Lo: Distance from slide block center to load center of gravity (cm)

Bore size (mm)	Allowable load weight WA (kg)
10	$\frac{\sigma \cdot 5.6}{Lo + 2.8}$
15	$\frac{\sigma \cdot 13.34}{Lo + 2.9}$
20	$\frac{\sigma \cdot 43.2}{Lo + 6}$
25	$\frac{\sigma \cdot 46.15}{Lo + 3.55}$
32	$\frac{\sigma \cdot 80}{Lo + 4}$
40	$\frac{\sigma \cdot 188.1}{Lo + 5.7}$

#### 7. Horizontal operation (pushing load, pusher)

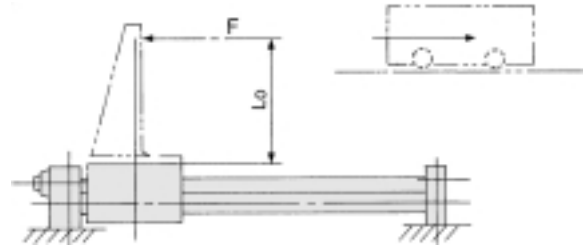

F: Drive (from slide block to position Lo) resistance force (kg)  
Lo: Distance from mounting surface to load center of gravity (cm)

Bore size (mm)	10	15	20
Allowable load weight (WA)(kg)	$\frac{\sigma \cdot 5.55}{1.95 + Lo}$	$\frac{\sigma \cdot 15.96}{2.4 + Lo}$	$\frac{\sigma \cdot 41.7}{2.8 + Lo}$
Bore size (mm)	25	32	40
Allowable load weight (WA)(kg)	$\frac{\sigma \cdot 58.9}{3.1 + Lo}$	$\frac{\sigma \cdot 106.65}{3.95 + Lo}$	$\frac{\sigma \cdot 228}{4.75 + Lo}$

#### 8. Horizontal operation (load, lateral offset Lo)

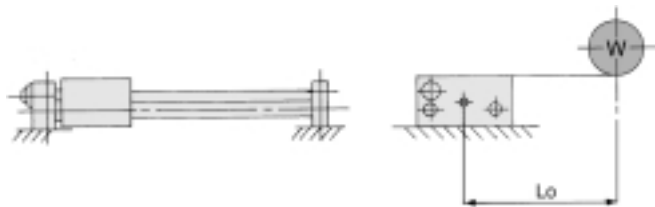

Lo: Distance from center of slide block to load's center of gravity (cm)

Bore size (mm)	10	15	20
Allowable load weight (WA)(kg)	$\frac{\sigma \cdot 15}{5 + Lo}$	$\frac{\sigma \cdot 45.5}{6.5 + Lo}$	$\frac{\sigma \cdot 80.7}{8 + Lo}$
Bore size (mm)	25	32	40
Allowable load weight (WA)(kg)	$\frac{\sigma \cdot 144}{9 + Lo}$	$\frac{\sigma \cdot 275}{11 + Lo}$	$\frac{\sigma \cdot 520}{13 + Lo}$



# Series REAL Model Selection 4

## Design Parameters 3

### Vertical Operation

When operating a load vertically, it should be operated within the allowable load weights and maximum operating pressures shown in the table below. Use caution, as operating above the prescribed values may lead to dropping of the load.

Bore size (mm)	Model	Allowable load weight Wv (kg)	Max. operating pressure Pv (MPa)
10	REAL10	2.7	0.55
15	REAL15	7.0	0.65
20	REAL20	11.0	0.65
25	REAL25	18.5	0.65
32	REAL32	30.0	0.65
40	REAL40	47.0	0.65

Note) Use caution, as there is a possibility of breaking the magnetic coupling if operated above the maximum operating pressure.

### Stroke Adjustment

The adjustment bolt is adjusted to the optimum position for smooth acceleration and deceleration at the time of shipment, and should be operated at the full stroke. When stroke adjustment is necessary, the maximum amount of adjustment on one side is 2mm. (Do not adjust more than 2mm, as it will not be possible to obtain smooth acceleration and deceleration.)

#### Stroke Adjustment

Loosen the hexagon nut, and after performing the stroke adjustment from the plate side with a hexagon wrench, retighten and secure the hexagon nut.

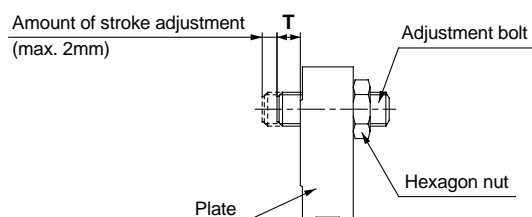

### Adjustment Bolt Position (at Shipment), Hexagon Nut Tightening Torque

Model	T (mm)	Tightening torque (N·m)
REAL10	1	1.67
REAL15	1	
REAL20	1	3.14
REAL25	1	10.8
REAL32	1	23.5
REAL40	1	

### Intermediate Stops

The cushion effect (smooth start-up, soft stop) exists only before the stroke end in the stroke ranges indicated in the table below.

The cushion effect (smooth start-up, soft stop) cannot be obtained in an intermediate stop or a return from an intermediate stop using an external stopper, etc.

#### Cushion stroke

Model	Stroke (mm)
REAL10	20
REAL15	25
REAL20	30
REAL25	30
REAL32	30
REAL40	35

Max. Speed  
300  
mm/s

Basic Type  
REAL

Direct Mount Type  
REAR

Slider Type/Slide Bearing  
REAS

Slider Type/Ball Bushing  
REAL

High Precision Guide Type  
REAH

Max. Speed  
600  
mm/s

Direct Mount Type  
REBR

High Precision Guide Type  
REBH

Auto Switches

Order Made

# Series REAL

## Construction/ø10, ø15

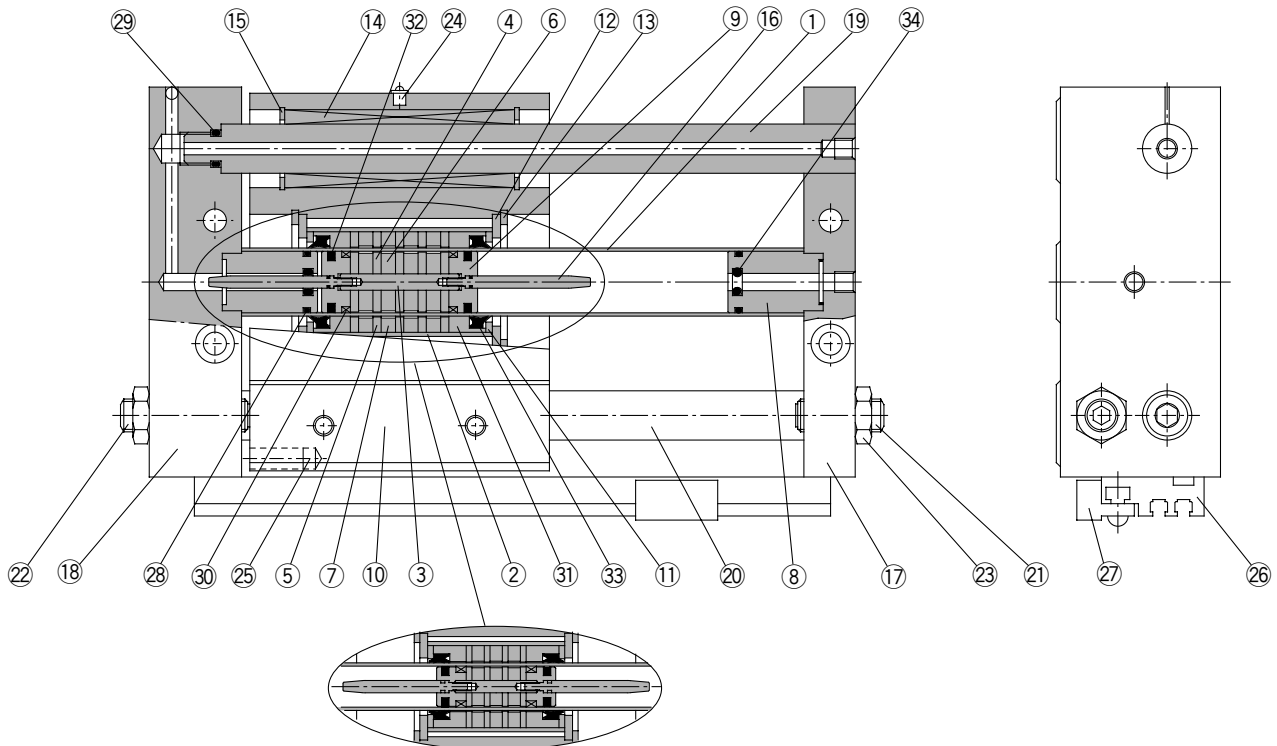

**REAL10**

### Parts list

No.	Description	Material	Note
1	Cylinder tube	Stainless steel	
2	External slider tube	Aluminum alloy	
3	Shaft	Stainless steel	
4	Piston side yoke	Rolled steel plate	Zinc chromated
5	External slider side yoke	Rolled steel plate	Zinc chromated
6	Magnet A	Rare earth magnet	
7	Magnet B	Rare earth magnet	
8	Cushion seal holder	Aluminum alloy	Anodized
9	Piston	Brass	Electroless nickel plated
10	Slide block	Aluminum alloy	Hard anodized
11	Spacer	Rolled steel plate	Nickel plated
12	Slider spacer	Rolled steel plate	Nickel plated
13	Snap ring	Carbon tool steel	Nickel plated
14	Ball bushing	-	
15	Snap ring	Carbon tool steel	Nickel plated
16	Cushion ring	Stainless steel	
17	Plate A	Aluminum alloy	Hard anodized

### Parts list

No.	Description	Material	Note
18	Plate B	Aluminum alloy	Hard anodized
19	Guide shaft A	Carbon steel	Hard chrome plated
20	Guide shaft B	Carbon steel	Hard chrome plated
21	Adjustment bolt A	Chromium molybdenum steel	Nickel plated
22	Adjustment bolt B	Chromium molybdenum steel	Nickel plated
23	Hexagon nut	Carbon steel	Nickel plated
24	Nipple	Carbon steel	Nickel plated (except REAL10)
25	Magnet for auto switch	Rare earth magnet	
26	Switch mounting rail	Aluminum alloy	
27	Auto switch	-	
28*	Cylinder tube gasket	NBR	
29*	Guide shaft gasket	NBR	
30*	Wear ring A	Special resin	
31*	Wear ring B	Special resin	
32*	Piston seal	NBR	
33*	Scraper	NBR	
34*	Cushion seal	NBR	

\* Seal kits are sets consisting of items 28 through 34 above, and can be ordered using the kit number for each bore size.

### Replacement parts: Seal kits

Bore size (mm)	Kit no.	Contents
10	REAS10-PS	Above numbers
15	REAS15-PS	28, 29, 30, 31, 32, 33, 34

Construction/ø20 to ø40

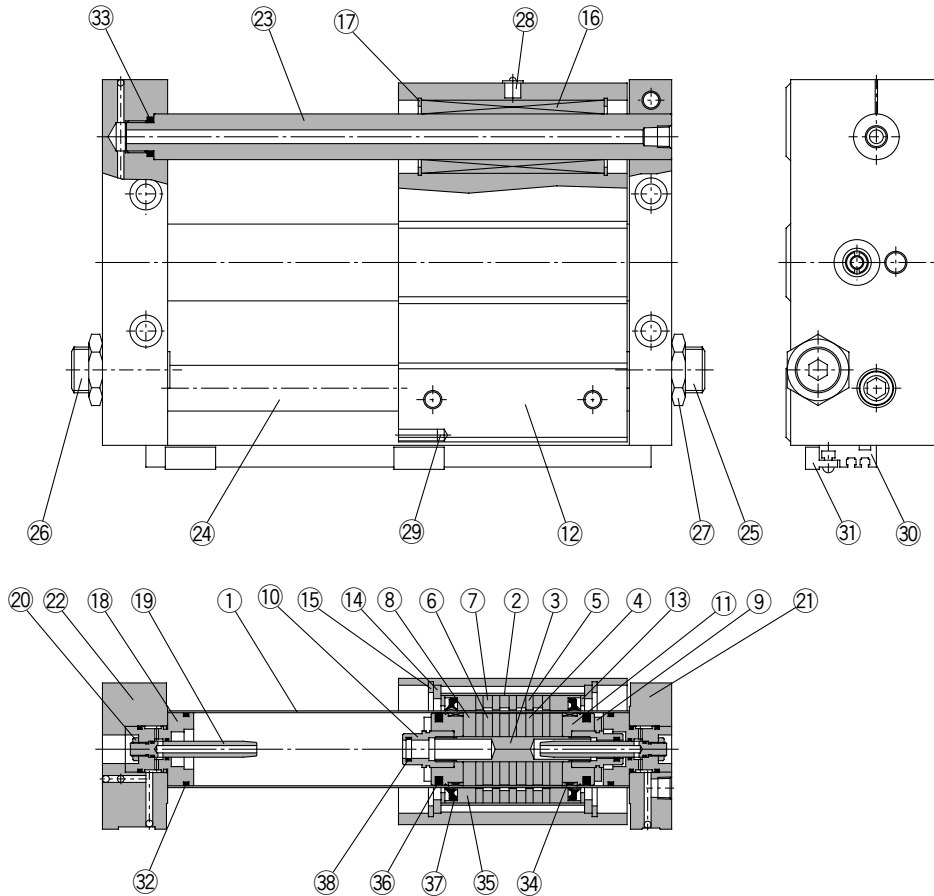

Parts list

No.	Description	Material	Note
1	Cylinder tube	Stainless steel	
2	External slider tube	Aluminum alloy	
3	Shaft	Stainless steel	
4	Piston side yoke	Rolled steel plate	Zinc chromated
5	External slider side yoke	Rolled steel plate	Zinc chromated
6	Magnet A	Rare earth magnet	
7	Magnet B	Rare earth magnet	
8	Piston side spacer	Aluminum alloy	Chromated
9	Bumper	Urethane rubber	
10	Cushion seal holder	Aluminum alloy	Chromated
11	Piston	Aluminum alloy	Chromated
12	Slide block	Aluminum alloy	Hard anodized
13	Spacer	Rolled steel plate	Nickel plated
14	Slider spacer	Carbon steel	Nickel plated
15	Snap ring	Carbon tool steel	Nickel plated
16	Ball bushing	-	
17	Snap ring	Carbon tool steel	Nickel plated
18	Cushion ring holder	Aluminum alloy	Anodized
19	Cushion ring	Brass	Electroless nickel plated (REAL32, 40)
		Stainless steel	REAL20, 25

Parts list

No.	Description	Material	Note
20	Lock nut B	Carbon steel	Nickel plated
21	Plate A	Aluminum alloy	Hard anodized
22	Plate B	Aluminum alloy	Hard anodized
23	Guide shaft A	Carbon steel	Hard chrome plated
24	Guide shaft B	Carbon steel	Hard chrome plated
25	Adjustment bolt A	Chromium molybdenum steel	Nickel plated
26	Adjustment bolt B	Chromium molybdenum steel	Nickel plated
27	Hexagon nut	Carbon steel	Nickel plated
28	Nipple	Brass	Nickel plated
29	Magnet for auto switch	Rare earth magnet	
30	Switch mounting rail	Aluminum alloy	
31	Auto switch	-	
32*	Cylinder tube gasket	NBR	
33*	Guide shaft gasket	NBR	
34*	Wear ring A	Special resin	
35*	Wear ring B	Special resin	
36*	Piston seal	NBR	
37*	Scraper	NBR	
38*	Cushion seal	NBR	

\* Seal kits are sets consisting of items 32 through 38 above, and can be ordered using the kit number for each bore size.

Replacement parts: Seal kits

Bore size (mm)	Kit no.	Contents
20	REAS20-PS	Above numbers 32, 33, 34, 35, 36, 37, 38
25	REAS25-PS	
32	REAS32-PS	
40	REAS40-PS	

Max. Speed  
300  
mm/s

Basic Type  
REA

Direct Mount Type  
REAR

Slider Type/Slide Bearing  
REAS

Slider Type/Ball Bushing  
REAL

High Precision Guide Type  
REAH

Max. Speed  
600  
mm/s

Direct Mount Type  
REBR

High Precision Guide Type  
REBH

Auto Switches

Order Made



Dimensions/ø15 to ø40

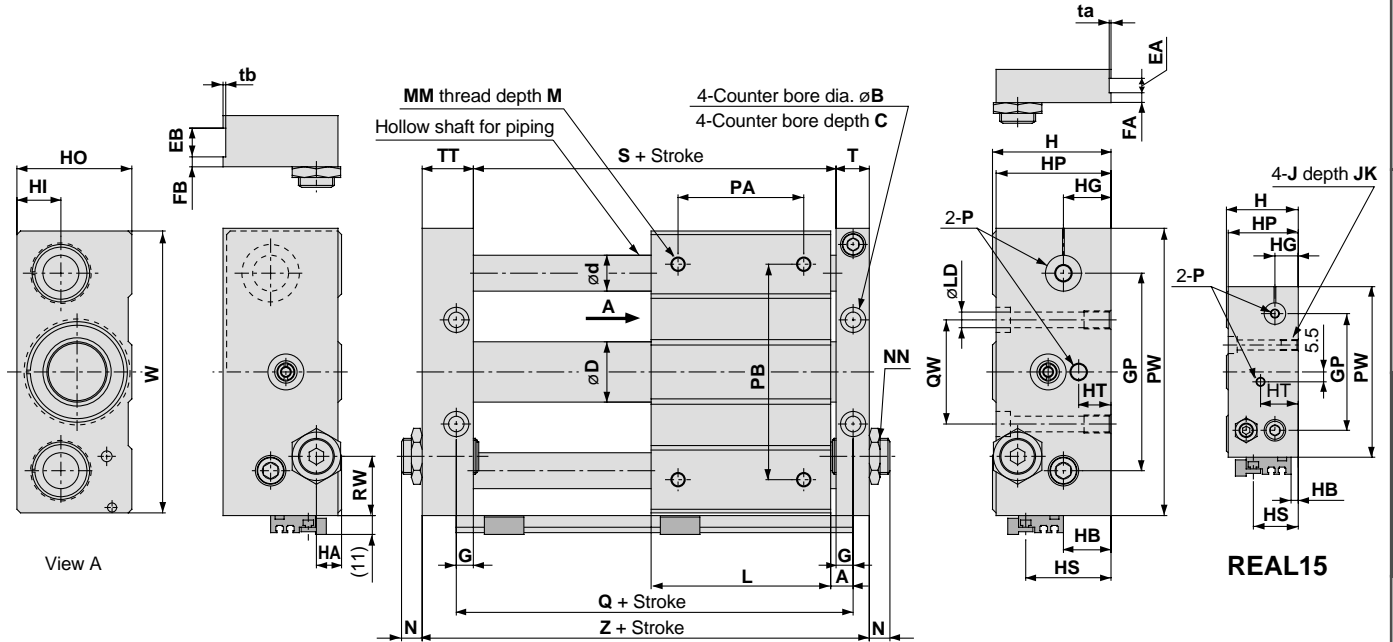

Model	A	B	C	D	d	EA	EB	FA	FB	G	GP	H	HA	HB	HG	HI	HO	HP
REAL15	7.5	9.5	5	16.6	12	6	13	3	6	6.5	65	40	6.5	4	16	14	38	39
REAL20	9.5	9.5	5	21.6	16	-	-	-	-	8.5	80	46	9	10	18	16	44	45
REAL25	9.5	11	6.5	26.4	16	8	14	4	7	8.5	90	54	9	18	23	21	52	53
REAL32	10.5	14	8	33.6	20	8	16	5	7	9.5	110	66	12	26.5	26.5	24.5	64	64
REAL40	11.5	14	8	41.6	25	10	20	5	10	10.5	130	78	12	35	30.5	28.5	76	74

Model	HS	HT	J	JK	L	LD	M	MM	N	NN	P	PA*	PB	PW
REAL15	25	21	M6 x 1.0	9.5	75	5.6	8	M5 x 0.8	7.5	M8 x 1.0	M5 x 0.8	45	70	95
REAL20	31	10	M6 x 1.0	10	86	5.6	10	M6 x 1.0	10	M10 x 1.0	Rc 1/8	50	90	120
REAL25	39	10	M8 x 1.25	10	86	7	10	M6 x 1.0	11	M14 x 1.5	Rc 1/8	60	100	130
REAL32	47.5	17	M10 x 1.5	15	100	9.2	12	M8 x 1.25	11.5	M20 x 1.5	Rc 1/8	70	120	160
REAL40	56	14	M10 x 1.5	15	136	9.2	12	M8 x 1.25	10.5	M20 x 1.5	Rc 1/4	90	140	190

Model	Q	QW	RW	S	T	TT	ta	tb	W	Z
REAL15	90	30	15	77	12.5	22.5	0.5	1.0	92	112
REAL20	105	40	28	88	16.5	25.5	-	-	117	130
REAL25	105	50	22	88	16.5	25.5	0.5	1.0	127	130
REAL32	121	60	33	102	18.5	28.5	0.5	1.0	157	149
REAL40	159	84	35	138	20.5	35.5	1.0	1.0	187	194

\* PA dimensions are for split from center.

Max. Speed  
300  
mm/s

Basic Type  
REAL

Direct Mount Type  
REAL

Slider Type/Slide Bearing  
REALS

Slider Type/Ball Bushing  
REAL

High Precision Guide Type  
REALH

Max. Speed  
600  
mm/s

Direct Mount Type  
REALR

High Precision Guide Type  
REALRH

Auto Switches

Order Made

# Series REAL

## Proper Auto Switch Mounting Position for Stroke End Detection

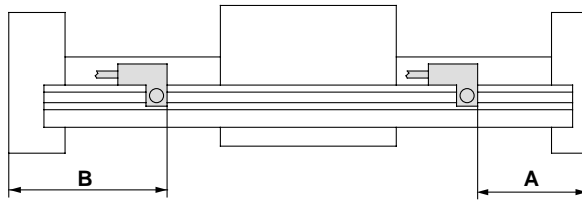

(mm)

Auto switch model Bore size (mm)	Dimension A				Dimension B			
	D-A73/A80	D-A72 D-A7□H/A80H D-A73C/A80C D-F7□J79 D-J79C D-F7□V	D-F7□W/J79W D-F7□WV D-F7LF (Note 1) D-F79F D-F7BAL	D-F7NTL	D-A73/A80	D-A72 D-A7□H/A80H D-A73C/A80C D-F7□J79 D-J79C D-F7□V	D-F7□W/J79W D-F7□WV D-F7LF (Note 1) D-F79F D-F7BAL	D-F7NTL
10	58	58.5	62.5	63.5	45	44.5	40.5	39.5
15	65	65.5	69.5	70.5	47	46.5	42.5	41.5
20	76	76.5	80.5	81.5	54	53.5	49.5	48.5
25	76	76.5	80.5	81.5	54	53.5	49.5	48.5
32	92	92.5	96.5	97.5	57	56.5	52.5	51.5
40	130	130.5	134.5	135.5	64	63.5	59.5	58.5

Note1 ) Model D-F7LF cannot be mounted on bore size  $\phi 10$ .

## Auto Switch Operating range

(mm)

Auto switch model Bore size (mm)	D-A7□/A80 D-A7□H/A80H D-A73C/A80C	D-F7□/J79 D-J79C D-F7□V D-F7NTL D-F7□W/J79W D-F7□WV D-F7BAL	D-F7LF D-F79F
10	6	3	4.5
15	6	4	4.5
20	6	3	4.5
25	6	3	4.5
32	6	3	4.5
40	6	3.5	4.5

Note) Operating ranges are standards including hysteresis, and are not guaranteed. Large variations may occur depending on the surrounding environment. (variations on the order of  $\pm 30\%$ )

## Auto Switch Mounting

When mounting an auto switch, the switch mounting screw should be screwed into a hexagon nut (M3 x 0.5) which has been inserted into the groove of the switch rail. (The tightening torque should be about 0.05 to 0.1N·m.)

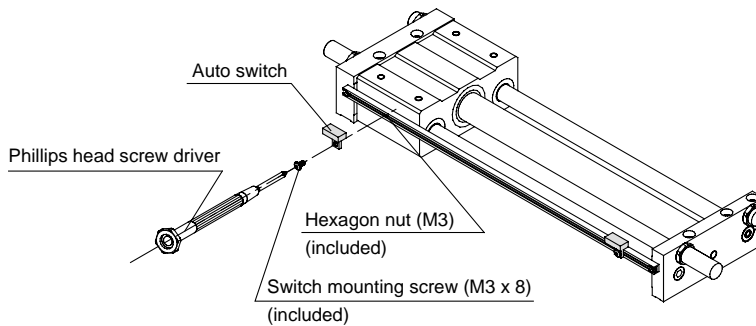

# Series REAH

## High Precision Guide Type

### How to Order

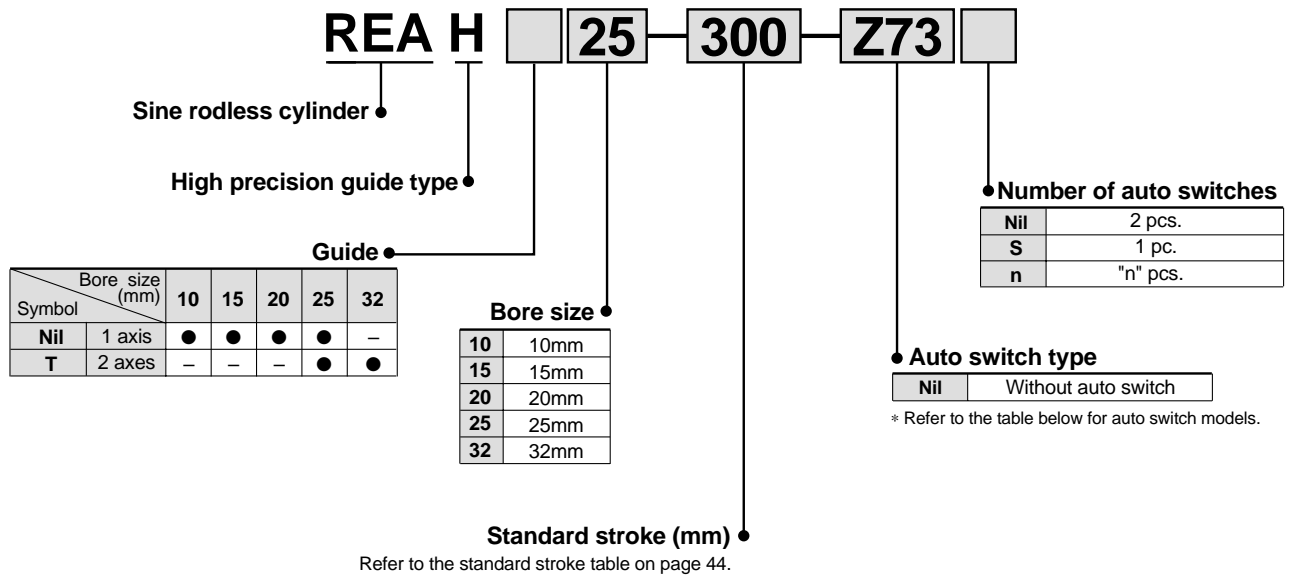

### Applicable auto switches / Refer to "Auto Switch Guide" (E-274-A) for further details on auto switch units. Refer to pages 84 and 85 for auto switch circuit diagrams.

Type	Special function	Electrical entry	Indicator light	Wiring (output)	Load voltage			Auto switch model		Lead wire length (m) <sup>Note 1)</sup>			Applicable load	
					DC	AC	Electrical entry direction	0.5 (Nil)	3 (L)	5 (Z)				
											Perpendicular	In-line		
Reed switches	—	Grommet	Yes	3 wire (NPN equiv.)	—	5V	—	—	Z76	●	●	—	IC circuit	—
				2 wire	12V	100V	—	Z73	●	●	●	—	Relay, PLC	
					5V, 12V	100V or less	—	Z80	●	●	—	IC circuit		
Solid state switches	Diagnostic indication (2 color indicator)	Grommet	Yes	3 wire (NPN)	24V	5V, 12V	—	Y69A	Y59A	●	●	○	IC circuit	Relay, PLC
				3 wire (PNP)				Y7PV	Y7P	●	●	○		
				2 wire				Y69B	Y59B	●	●	○	—	
				3 wire (NPN)				Y7NWV	Y7NW	●	●	○	IC circuit	
				3 wire (PNP)				Y7PWV	Y7PW	●	●	○	—	
				2 wire				Y7BWV	Y7BW	●	●	○	—	

Note 1) Lead wire length symbol 0.5m ..... Nil (Example) Y59A  
3m ..... L (Example) Y59AL  
5m ..... Z (Example) Y59AZ

Note 2) Solid state auto switches marked with a "○" are produced upon receipt of order.

# Series REAH



## Specifications

Bore size (mm)	10	15	20	25	32
Fluid	Air				
Action	Double acting				
Maximum operating pressure	0.7MPa				
Minimum operating pressure	0.2MPa				
Proof pressure	1.05MPa				
Ambient and fluid temperature	-10 to 60°C				
Piston speed	70 to 300mm/s				
Lubrication	Non-lube				
Stroke length tolerance	0 to 1.8mm				
Piping type	Centralized piping				
Piping port size	M5 x 0.8		Rc 1/8		

## Standard Strokes

Bore size (mm)	Number of axes	Standard stroke (mm)	Maximum manufacturable stroke (mm)
10	1 axis	150, 200, 300	500
15		150, 200, 300, 400, 500	750
20		200, 300, 400, 500, 600	1000
25		200, 300, 400, 500, 600, 800	1200
25	2 axes	200, 300, 400, 500, 600, 800, 1000	1200
32			1500

Note 1) Strokes exceeding the standard strokes are available as a special order.

Note 2) Intermediate strokes other than order made (refer to page 91 for XB10) are available by special order.

## Weights

Model	Standard stroke mm							
	150	200	300	400	500	600	800	1000
REAH10	1.2	1.3	1.6	–	–	–	–	–
REAH15	2.5	2.7	3.2	3.6	4.1	–	–	–
REAH20	–	3.5	4.0	4.4	4.9	5.4	–	–
REAH25	–	5.3	6.0	6.6	7.3	8.0	9.4	–
REAH25	–	6.2	7.3	8.3	9.4	10.4	12.5	14.6
REAH32	–	9.6	10.7	11.9	13.0	14.2	16.5	18.8

(kg)

## Magnetic Holding Force

Bore size (mm)	(N)				
	10	15	20	25	32
Holding force	53.9	137	231	363	588

## Theoretical Output

Bore size (mm)	Piston area (mm <sup>2</sup> )	(N)					
		Operating pressure (MPa)					
		0.2	0.3	0.4	0.5	0.6	0.7
10	78	15	23	31	39	46	54
15	176	35	52	70	88	105	123
20	314	62	94	125	157	188	219
25	490	98	147	196	245	294	343
32	804	161	241	322	402	483	563

Note) Theoretical output (N) = Pressure (MPa) x Piston area (mm<sup>2</sup>).



## ⚠ Specific Product Precautions

Be sure to read before handling. Refer to pages 92 through 94 for safety instructions and actuator precautions.

### Mounting

#### ⚠ Caution

1. The interior is protected to a certain extent by the top cover, however, when performing maintenance, etc., take care not to cause scratches or other damage to the cylinder tube, slide table or linear guide by striking them or placing objects on them.

The bore and exterior of tubes are manufactured to precise tolerances, so that even a slight deformation can cause malfunction.

2. Since the slide table is supported by precision bearings, do not apply strong impacts or large moment, etc., when mounting work pieces.

#### 3. Mounting of the cylinder body

The body is mounted using the square nuts, which are included, in the two T-slots on the bottom of the body. Refer to the table below for mounting bolt dimensions and tightening torque.

Model		REAH10	REAH15	REAH20	REAH25	REAH25	REATH32
Bolt dimensions	Screw size	M4 x 0.7	M5 x 0.8	M6 x 1.0	M6 x 1.0	M6 x 1.0	M8 x 1.25
	Dimension t	/7	/8	/9	/9	/9	/12
Tightening torque	N·m	1.37	2.65	4.4	4.4	4.4	13.2

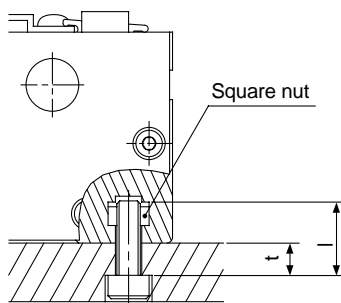

### Operation

#### ⚠ Caution

1. The unit can be used with a direct load within the allowable range, but when connecting to a load which has an external guide mechanism, careful alignment is necessary.

Since variation of the shaft center increases as the stroke becomes longer, a connection method should be devised which allows for this displacement.

2. Since the guide is adjusted at the time of shipment, unintentional movement of the adjustment setting should be avoided.
3. Contact SMC before operating in an environment where there will be contact with chips, dust (paper scraps, thread scraps, etc.) or cutting oil (gas oil, water, hot water, etc.).

4. Do not operate with the magnetic coupling out of position.

In case the magnetic coupling is out of position, push the external slider back into the correct position by hand at the end of the stroke (or correct the piston slider with air pressure).

# Series REAH Model Selection 1

**P<sub>v</sub>**: Maximum operating pressure for vertical operation (MPa)

**W<sub>v</sub>**: Allowable load weight for vertical operation (kg)

**α**: Load factor

$$\Sigma\alpha = \frac{\text{Load weight (W)}}{\text{Max. load weight (Wmax)}} + \frac{\text{Static moment (M)}}{\text{Allowable static moment (Mmax)}} + \frac{\text{Dynamic moment (Me)}}{\text{Allowable dynamic moment (Memax)}}$$

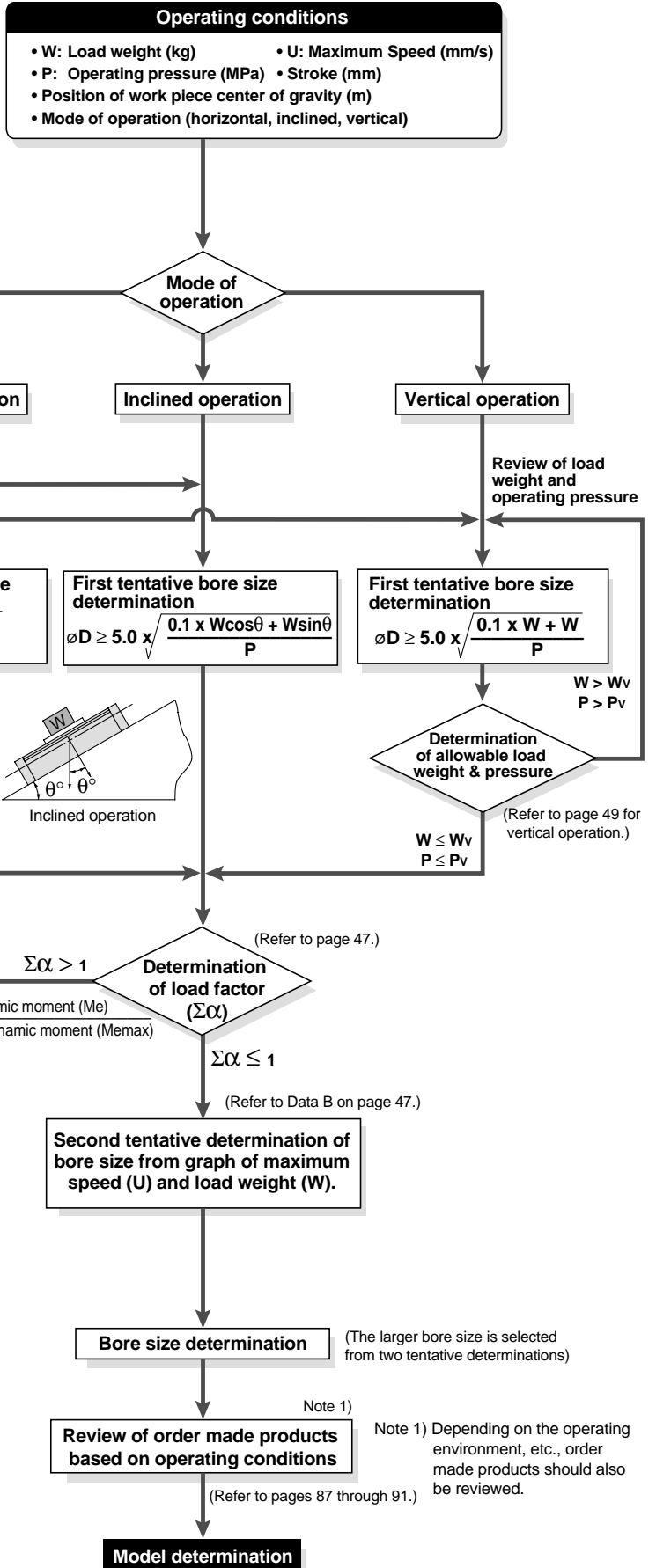

# Series REAH Model Selection 2

## Design Parameters 1

The maximum load weight and allowable moment will differ depending on the work piece mounting method, cylinder mounting orientation and piston speed. A determination of suitability for use should be performed so that the total ( $\Sigma\alpha_n$ ) of the load factors ( $\alpha_n$ ) for each weight and moment does not exceed 1.

$$\Sigma\alpha_n = \frac{\text{Load weight (W)}}{\text{Max. load weight (Wmax)}} + \frac{\text{Static moment (M)}}{\text{Allowable static moment (Mmax)}} + \frac{\text{Dynamic moment (Me)}}{\text{Allowable dynamic moment (Memax)}} \leq 1$$

## Load weight

Max. load weight (kg)

Model	W <sub>max</sub>
REAH10	4
REAH15	9
REAH20	16
REAH25	25
REAH25	
REAH32	40

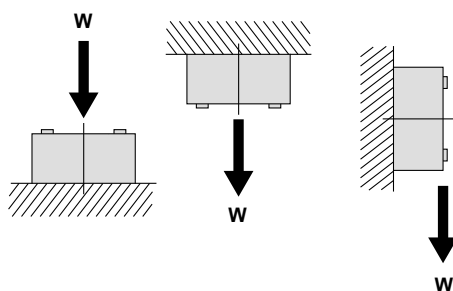

## Moment

Allowable moment (Static moment/Dynamic moment) (N·m)

Model	M <sub>1</sub>	M <sub>2</sub>	M <sub>3</sub>	Model	M <sub>1</sub>	M <sub>2</sub>	M <sub>3</sub>
REAH10	1.5	2.5	1.5	REAH25	28	26	28
REAH15	10	16	10	REAH25	56	85	56
REAH20	13	16	13	REAH32	64	96	64

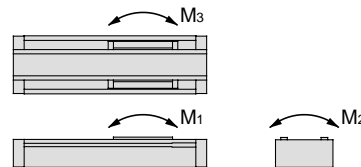

## Static moment

Moment generated by the self weight of the load even when the cylinder is stopped

■ Pitch moment  
M<sub>1</sub> = W·L

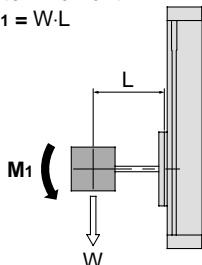

■ Roll moment  
M<sub>2</sub> = W·L

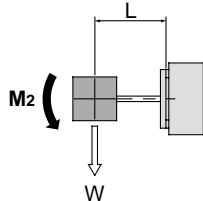

■ Yaw moment  
M<sub>3</sub> = W(L-A)

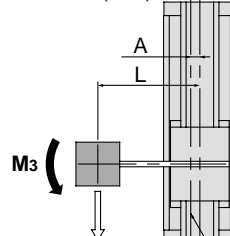

(mm)

Model	A
REAH10	15
REAH15	17.5
REAH20	19.5
REAH25	23.5
REAH25	0°
REAH32	0°

\* Since there are 2 guides, the guides' central axis and the cylinder's central axis are the same.

## Dynamic moment

Moment generated by the load equivalent to the impact at the stroke end

$$We = 5 \times 10^{-3} \cdot W \cdot g \cdot U$$

We: Load equivalent to impact [N]  
W: Load weight [kg]  
U: Maximum speed [mm/s]  
g: Gravitational acceleration (approx. 9.8m/s<sup>2</sup>)

■ Pitch moment  
Me<sub>1</sub> = 1/3·We·L

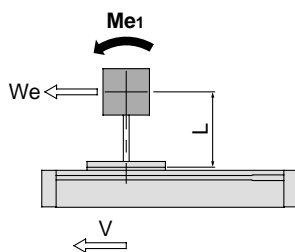

■ Yaw moment  
Me<sub>3</sub> = 1/3·We(L-A)

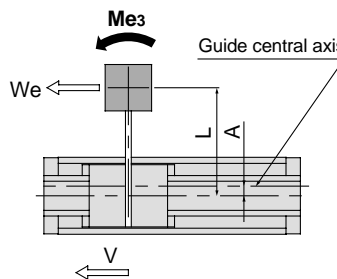

(mm)

Model	A
REAH10	15
REAH15	17.5
REAH20	19.5
REAH25	23.5
REAH25	0°
REAH32	0°

\* Since there are 2 guides, the guides' central axis and the cylinder's central axis are the same.

<Data (B) Maximum speed Load weight chart>

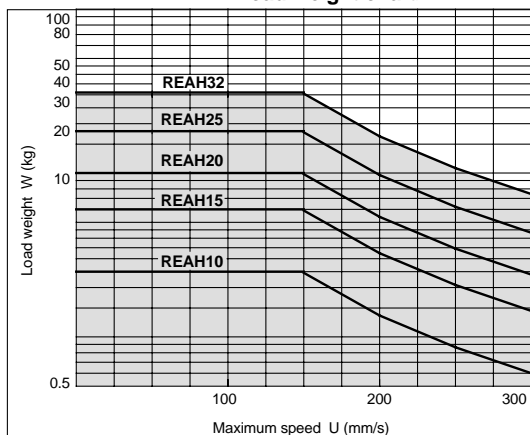

# Series REAH Model Selection 3

## Selection Calculation

The selection calculation finds the load factors ( $\alpha_n$ ) of the items below, where the total ( $\Sigma\alpha_n$ ) does not exceed 1.

$$\Sigma\alpha_n = \alpha_1 + \alpha_2 + \alpha_3 \leq 1$$

Item	Load factor $\alpha_n$	Note
1. Max. load weight	$\alpha_1 = W/W_{max}$	Review W. W <sub>max</sub> is the maximum load weight.
2. Static moment	$\alpha_2 = M/M_{max}$	Review M <sub>1</sub> , M <sub>2</sub> , M <sub>3</sub> . M <sub>max</sub> is the allowable moment.
3. Dynamic moment	$\alpha_3 = M_e/M_{e_{max}}$	Review M <sub>e1</sub> , M <sub>e3</sub> . M <sub>e_{max}}</sub> is the allowable moment.

U: Maximum speed

## Calculation examples

### Operating conditions

Cylinder: REAH15  
Mounting: Horizontal wall mounting  
Maximum speed: U = 300 [mm/s]  
Load weight: W = 1 [kg] (excluding weight of arm section)  
L<sub>1</sub> = 200 [mm]  
L<sub>2</sub> = 200 [mm]

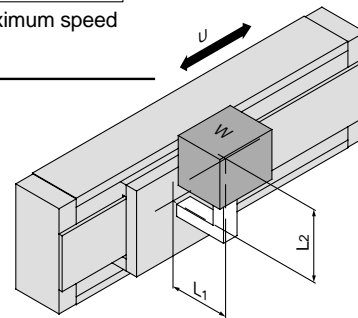

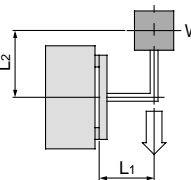
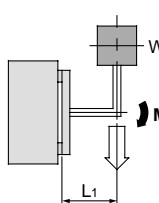
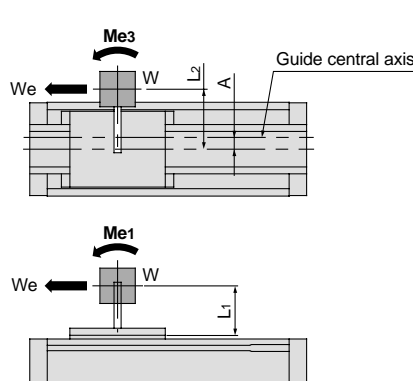
Item	Load factor $\alpha_n$	Note
<b>1. Maximum load weight</b> 	$\alpha_1 = W/W_{max}$ $= 1/9$ $= \mathbf{0.111}$	Review W.
<b>2. Static moment</b> 	$M_2 = W \cdot L_1$ $= 10 \cdot 0.2$ $= 2 \text{ [N}\cdot\text{m]}$ $\alpha_2 = M_2/M_2 \text{ max}$ $= 2/16$ $= \mathbf{0.125}$	$W = 1 \text{ [kg]}$ $= 10 \text{ [N]}$ Review M <sub>2</sub> . Since M <sub>1</sub> & M <sub>3</sub> are not generated, review is unnecessary.
<b>3. Dynamic moment</b> 	$W_e = 5 \times 10^{-3} \cdot W \cdot g \cdot U$ $= 5 \times 10^{-3} \cdot 19.8 \cdot 300$ $= 15 \text{ [N]}$ $M_{e3} = 1/3 \cdot W_e \cdot (L_2 - A)$ $= 1/3 \cdot 15 \cdot 0.182$ $= 0.91 \text{ [N}\cdot\text{m]}$ $\alpha_3 = M_{e3}/M_{e3 \text{ max}}$ $= 0.91/10$ $= \mathbf{0.091}$	Review M <sub>e3</sub> .
	$M_{e1} = 1/3 \cdot W_e \cdot L_1$ $= 1/3 \cdot 15 \cdot 0.2$ $= 0.1 \text{ [N}\cdot\text{m]}$ $\alpha_4 = M_{e1}/M_{e1 \text{ max}}$ $= 1/10$ $= \mathbf{0.1}$	Review M <sub>e1</sub> .

$$\Sigma\alpha_n = \alpha_1 + \alpha_2 + \alpha_3 + \alpha_4$$

$$= 0.111 + 0.125 + 0.091 + 0.10$$

$$= 0.427 \quad \text{Can be used based on } \Sigma\alpha_n = 0.427 \leq 1$$

# Series REAH Model Selection 4

Max. Speed  
300  
mm/s

Basic Type  
REA

Direct Mount Type  
REAR

Slider Type/Slide Bearing  
REAS

Slider Type/Ball Bushing  
REAL

High Precision Guide Type  
REAH

Max. Speed  
600  
mm/s

Direct Mount Type  
REBR

High Precision Guide Type  
REBH

Auto Switches

Order Made

## Design Parameters 2

### Table Deflection

Table deflection due to pitch moment load

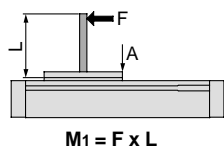

Table deflection due to roll moment load

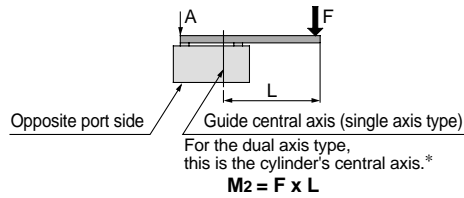
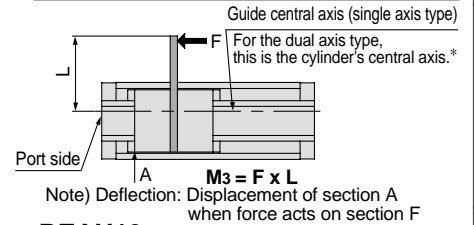
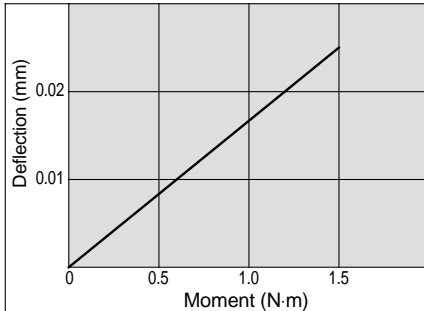

Table deflection due to yaw moment load



#### REAH10



#### REAH10

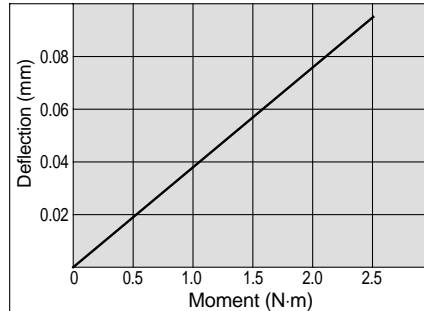

#### REAH10

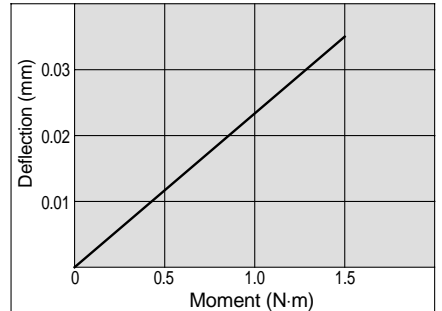

#### REAH15, 20, 25

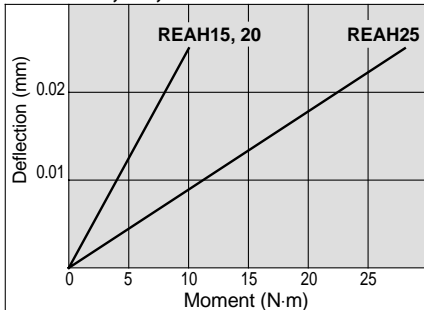

#### REAH15, 20, 25

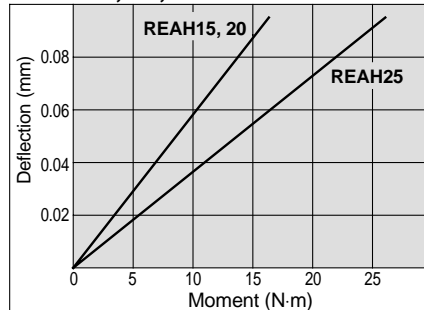

#### REAH15, 20, 25

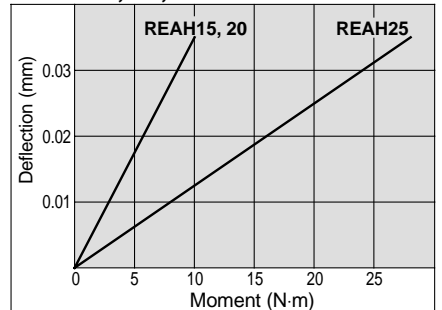

#### REAH25, 32

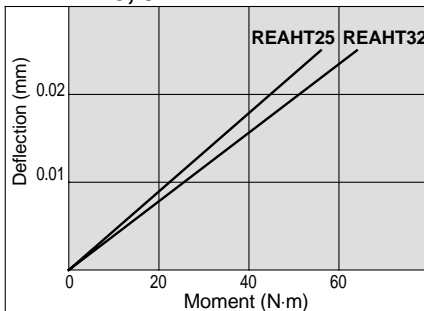

#### REAH25, 32

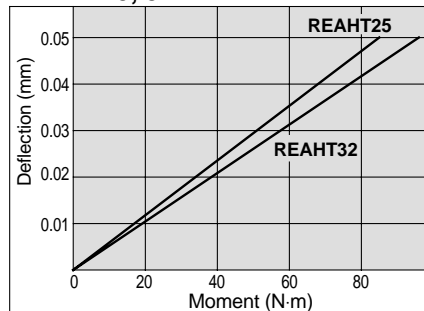

#### REAH25, 32

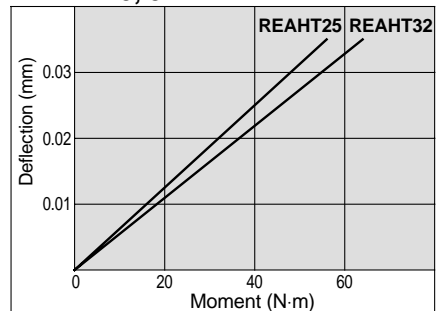

### Vertical Operation

When using in vertical operation, prevention of work piece dropping due to breaking of the magnetic coupling should be considered. The allowable load weight and maximum operating pressure should be as shown in the table below.

Model	Allowable load weight Wv (kg)	Max. operating pressure Pv (MPa)
REAH10	2.7	0.55
REAH15	7.0	0.65
REAH20	11.0	0.65
REAH25	18.5	0.65
REAH25	18.5	0.65
REAH32	30.0	0.65

### Intermediate Stops

The cushion effect (smooth start-up, soft stop) exists only before the stroke end in the stroke ranges indicated in the table below.

The cushion effect (smooth start-up, soft stop) cannot be obtained in an intermediate stop or a return from an intermediate stop using an external stopper, etc.

#### Cushion stroke

Model	Stroke (mm)
REAH10	20
REAH15	25
REAH20	30
REAH25	30
REAH25	30
REAH32	30

# Series REAH

## Stroke Adjustment

The adjustment bolt is adjusted to the optimum position for smooth acceleration and deceleration at the time of shipment, and should be operated at the full stroke. When stroke adjustment is necessary, the maximum amount of adjustment on one side is 2mm. (Do not adjust more than 2mm, as it will not be possible to obtain smooth acceleration and deceleration.)

Do not adjust based on the stopper's movement, as this can cause cylinder damage.

### Stroke Adjustment

Loosen the round head Phillips screws, and remove the top covers and dust covers (4pcs.). Then loosen the hexagon nut, and after performing the stroke adjustment from the plate side with a hexagon wrench, retighten and secure the hexagon nut.

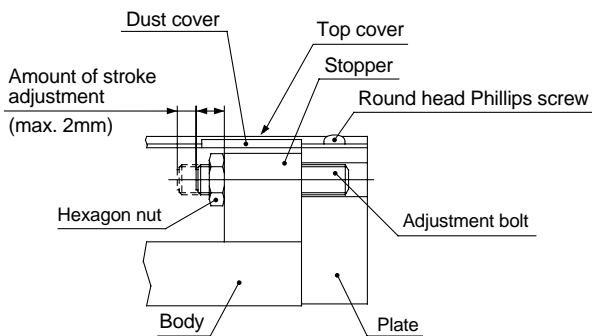

## Adjustment Bolt Position (at Shipment), Hexagon Nut Tightening Torque

Model	T (mm)	Tightening torque (N·m)
REAH10	7	1.67
REAH15	7	
REAH20	7	
REAH25	9	3.14
REAH25	9	
REAH32	9	

After adjusting the stroke, replace the top covers and dust covers. Tighten the round head Phillips screws for securing the top covers with a torque of 0.58N·m.

Construction/ $\phi 10, \phi 15$

Single axis type/REAH

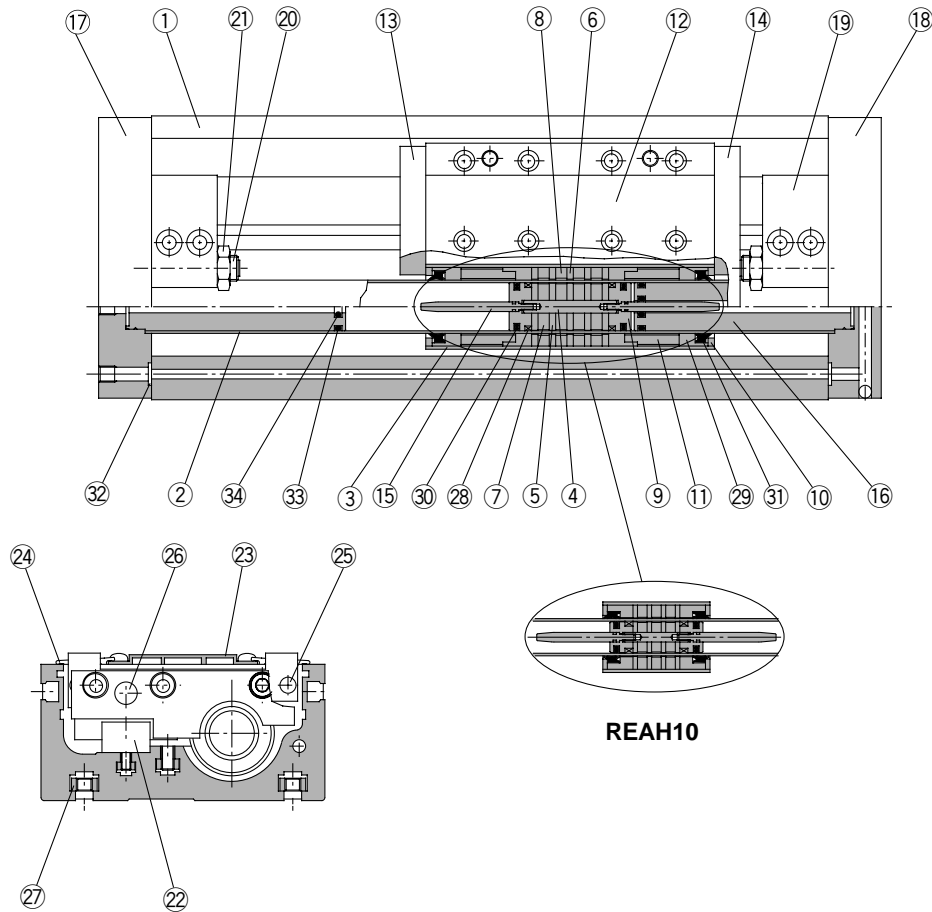

Parts list

No.	Description	Material	Note
1	Body	Aluminum alloy	Hard anodized
2	Cylinder tube	Stainless steel	
3	External slider tube	Aluminum alloy	
4	Shaft	Stainless steel	
5	Piston side yoke	Rolled steel plate	Zinc chromated
6	External slider side yoke	Rolled steel plate	Zinc chromated
7	Magnet A	Rare earth magnet	
8	Magnet B	Rare earth magnet	
9	Piston	Brass	Electroless nickel plated
10	Spacer	Rolled steel plate	Nickel plated
11	Space ring	Aluminum alloy	Chromated (except REAH10)
12	Slide table	Aluminum alloy	Hard anodized
13	Side plate A	Aluminum alloy	Hard anodized
14	Side plate B	Aluminum alloy	Hard anodized
15	Cushion ring	Stainless steel	
16	Internal stopper	Aluminum alloy	Anodized
17	Plate A	Aluminum alloy	Hard anodized

Replacement parts: Seal kits

Bore size (mm)	Kit no.	Contents
10	REAH10-PS	Above numbers
15	REAH15-PS	28, 29, 30, 31, 32, 33, 34

Parts list

No.	Description	Material	Note
18	Plate B	Aluminum alloy	Hard anodized
19	Stopper	Aluminum alloy	Anodized
20	Adjustment bolt	Chromium molybdenum steel	Nickel plated
21	Hexagon nut	Carbon steel	Nickel plated
22	Linear guide		
23	Top cover	Aluminum alloy	Hard anodized
24	Dust cover	Special resin	
25	Magnet (for auto switch)	Rare earth magnet	
26	Parallel pin	Carbon steel	Nickel plated
27	Square nut for body mounting	Carbon steel	Nickel plated (accessory)
28*	Wear ring A	Special resin	
29*	Wear ring B	Special resin	
30*	Piston seal	NBR	
31*	Scraper	NBR	
32*	O-ring	NBR	
33*	O-ring	NBR	
34*	Cushion seal	NBR	

\* Seal kits are sets consisting of items 28 through 34 above, and can be ordered using the kit number for each bore size.

Max. Speed  
300  
mm/s

Basic Type  
REAH

Direct Mount Type  
REAR

Slider Type/Slide Bearing  
REAS

Slider Type/Ball Bushing  
REAL

High Precision Guide Type  
REAH

Max. Speed  
600  
mm/s

Direct Mount Type  
REBR

High Precision Guide Type  
REBH

Auto Switches

Order Made

# Series REAH

Construction/ø20, ø25

Single axis/REAH

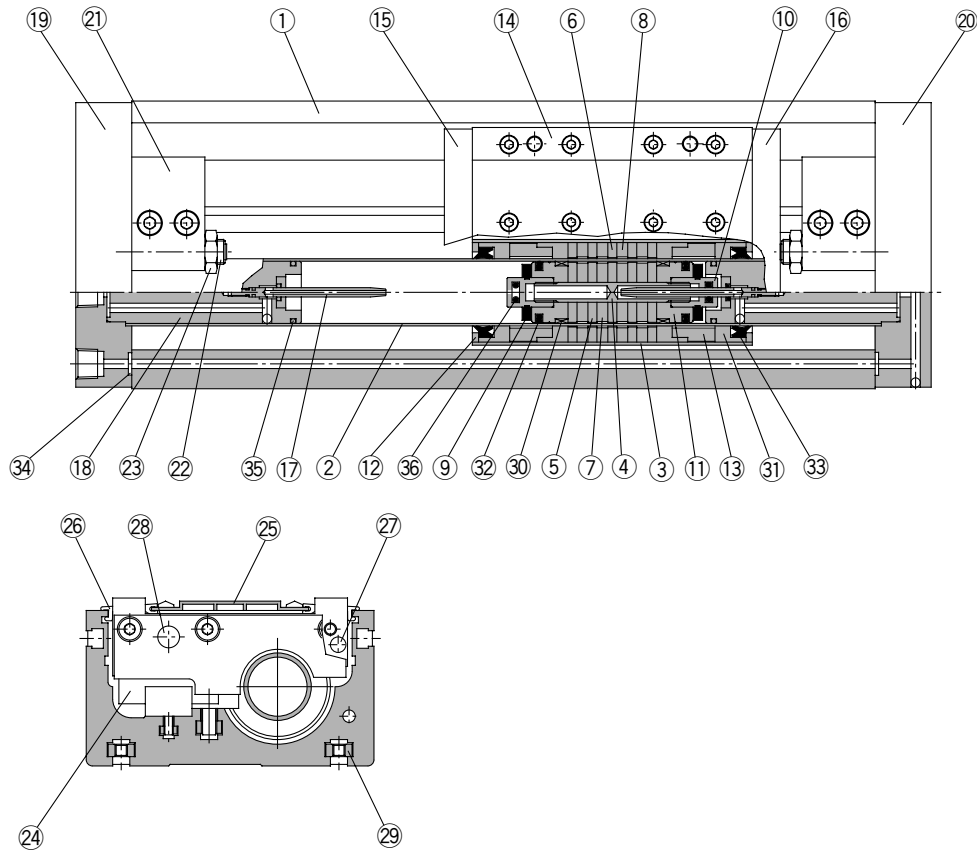

## Parts list

No.	Description	Material	Note
1	Body	Aluminum alloy	Hard anodized
2	Cylinder tube	Stainless steel	
3	External slider tube	Aluminum alloy	
4	Shaft	Stainless steel	
5	Piston side yoke	Rolled steel plate	Zinc chromated
6	External slider side yoke	Rolled steel plate	Zinc chromated
7	Magnet A	Rare earth magnet	
8	Magnet B	Rare earth magnet	
9	Bumper	Urethane rubber	
10	Cushion seal holder	Aluminum alloy	Chromated
11	Piston	Aluminum alloy	Chromated
12	Spacer	Rolled steel plate	Nickel plated
13	Space ring	Aluminum alloy	Chromated
14	Slide table	Aluminum alloy	Hard anodized
15	Side plate A	Aluminum alloy	Hard anodized
16	Side plate B	Aluminum alloy	Hard anodized
17	Cushion ring	Stainless steel	
18	Internal stopper	Aluminum alloy	Anodized

## Parts list

No.	Description	Material	Note
19	Plate A	Aluminum alloy	Hard anodized
20	Plate B	Aluminum alloy	Hard anodized
21	Stopper	Aluminum alloy	Anodized
22	Adjustment bolt	Chromium molybdenum steel	Nickel plated
23	Hexagon nut	Carbon steel	Nickel plated
24	Linear guide		
25	Top cover	Aluminum alloy	Hard anodized
26	Dust cover	Special resin	
27	Magnet (for auto switch)	Rare earth magnet	
28	Parallel pin	Carbon steel	Nickel plated
29	Square nut for body mounting	Carbon steel	Nickel plated (accessory)
30*	Wear ring A	Special resin	
31*	Wear ring B	Special resin	
32*	Piston seal	NBR	
33*	Scraper	NBR	
34*	O-ring	NBR	
35*	O-ring	NBR	
36*	Cushion seal	NBR	

\* Seal kits are sets consisting of items 30 through 36 above, and can be ordered using the kit number for each bore size.

## Replacement parts: Seal kits

Bore size (mm)	Kit no.	Contents
20	REAH20-PS	Above numbers
25	REAH25-PS	30, 31, 32, 33, 34, 35, 36



Construction/ø25, ø32

Dual axis type/REAH

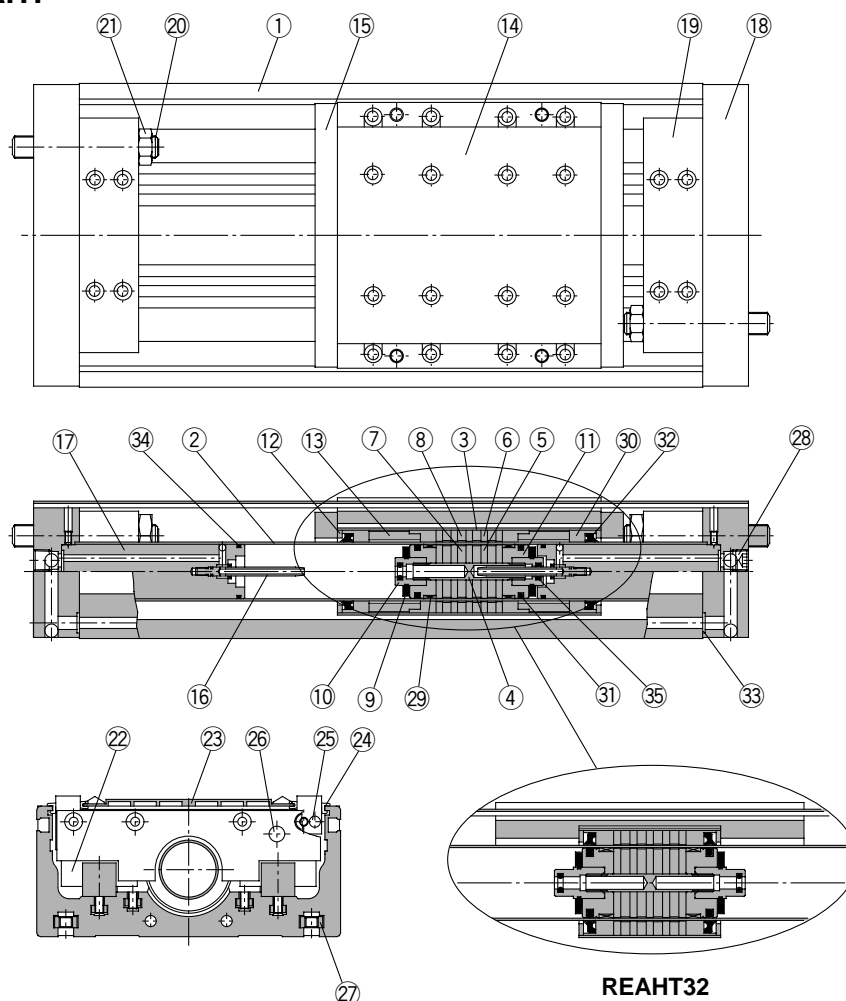

REAH32

Parts list

No.	Description	Material	Note
1	Body	Aluminum alloy	Hard anodized
2	Cylinder tube	Stainless steel	
3	External slider tube	Aluminum alloy	
4	Shaft	Stainless steel	
5	Piston side yoke	Rolled steel plate	Zinc chromated
6	External slider side yoke	Rolled steel plate	Zinc chromated
7	Magnet A	Rare earth magnet	
8	Magnet B	Rare earth magnet	
9	Bumper	Urethane rubber	
10	Cushion seal holder	Aluminum alloy	Chromated
11	Piston	Aluminum alloy	Chromated
12	Spacer	Rolled steel plate	Nickel plated
13	Space ring	Aluminum alloy	Chromated (except REAH32)
14	Slide table	Aluminum alloy	Hard anodized
15	Side plate	Aluminum alloy	Hard anodized (except REAH32)
16	Cushion ring	Brass	Electroless nickel plated (REAH32)
		Stainless steel	REAH25
17	Internal stopper	Aluminum alloy	Anodized

Replacement parts: Seal kits

Bore size (mm)	Kit no.	Contents
25	REAH25-PS	Above numbers
32	REAH32-PS	29, 30, 31, 32, 33, 34, 35

Parts list

No.	Description	Material	Note
18	Plate	Aluminum alloy	Hard anodized
19	Stopper	Aluminum alloy	Anodized
20	Adjustment bolt	Chromium molybdenum steel	Nickel plated
21	Hexagon nut	Carbon steel	Nickel plated
22	Linear guide		
23	Top cover	Aluminum alloy	Hard anodized
24	Dust cover	Special resin	
25	Magnet (for auto switch)	Rare earth magnet	
26	Parallel pin	Carbon steel	Nickel plated
27	Square nut for body mounting	Carbon steel	Nickel plated (accessory)
28	Hexagon socket taper plug	Carbon steel	Nickel plated
29*	Wear ring A	Special resin	
30*	Wear ring B	Special resin	
31*	Piston seal	NBR	
32*	Scraper	NBR	
33*	O-ring	NBR	
34*	O-ring	NBR	
35*	Cushion seal	NBR	

\* Seal kits are sets consisting of items 29 through 35 above, and can be ordered using the kit number for each bore size.

Max. Speed  
300  
mm/s

Basic Type  
REAH

Direct Mount Type  
REAR

Slider Type/Slide Bearing  
REAS

Slider Type/Ball Bushing  
REAL

High Precision Guide Type  
REAH

Max. Speed  
600  
mm/s

Direct Mount Type  
REBR

High Precision Guide Type  
REBH

Auto Switches

Order Made

# Series REAH

## Dimensions/ $\varnothing 10$

### Single axis type/REAH

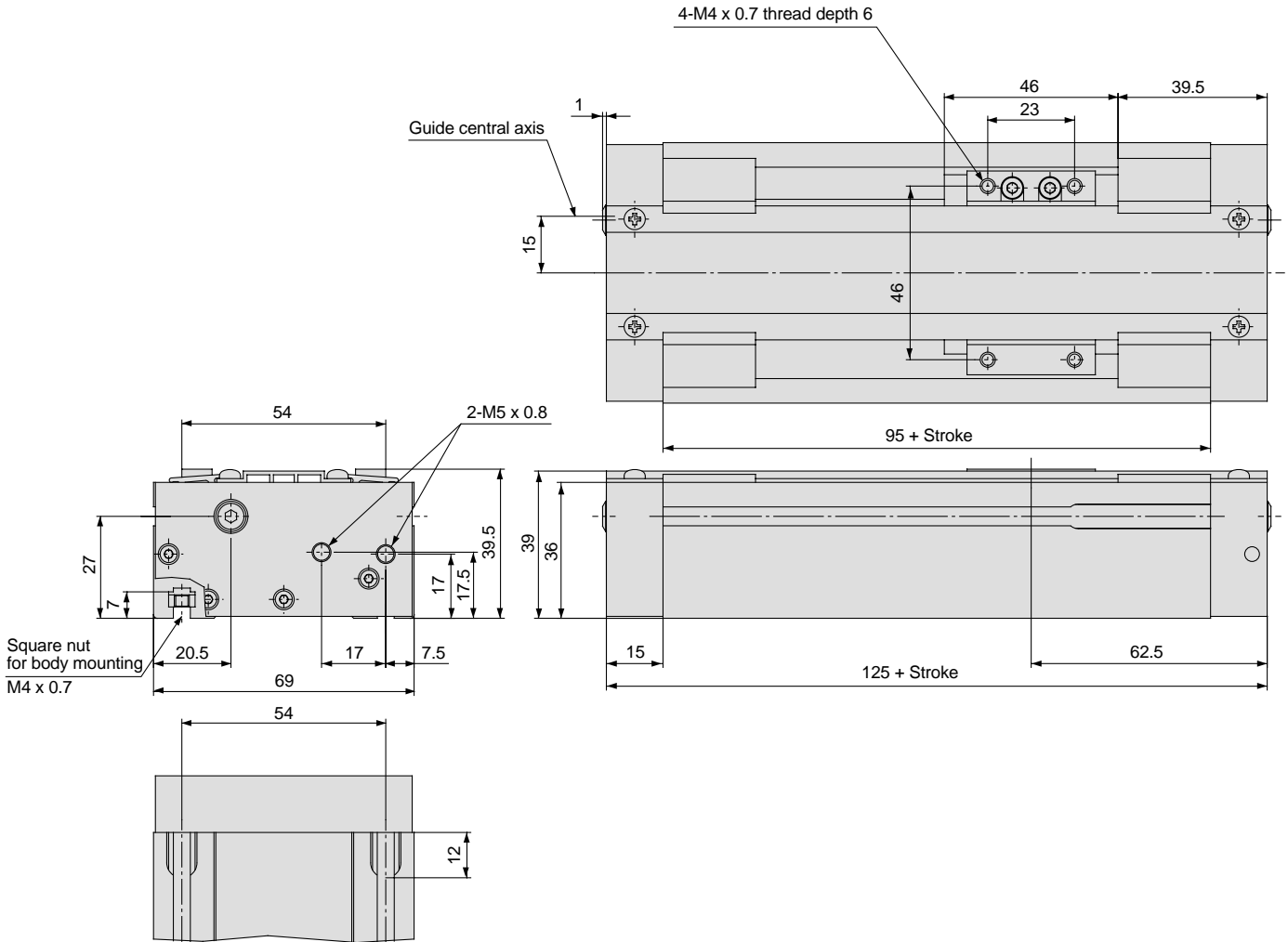

**Dimensions/ø15, ø20, ø25**

**Single axis type/REAH**

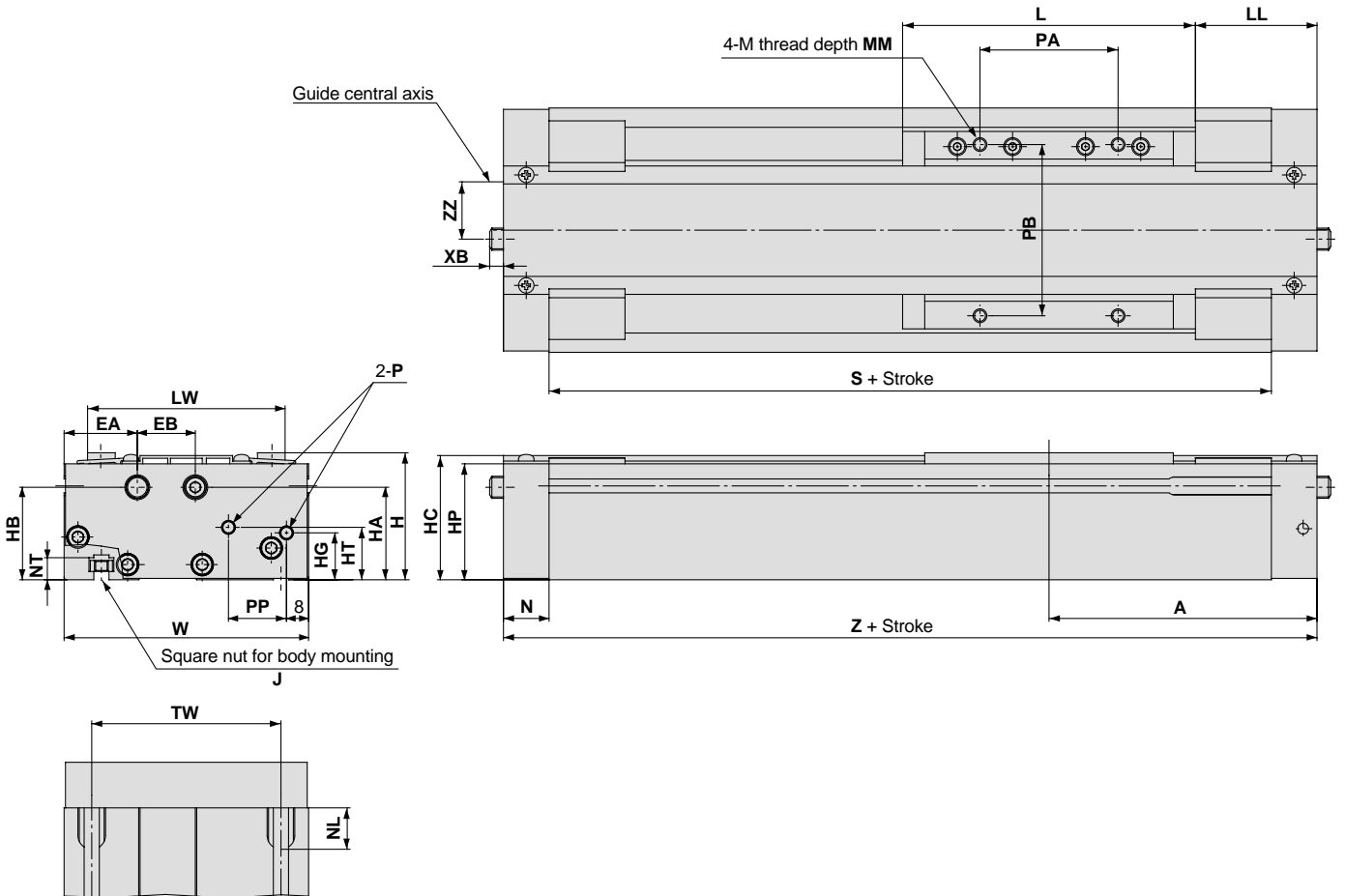

Model	A	EA	EB	H	HA	HB	HC	HG	HP	HT	J	L	LL	LW	M	MM
REAH15	97	26.5	21	46	33.5	33.5	45	17	42	19	M5 x 0.8	106	44	71.5	M5 x 0.8	8
REAH20	102.5	26.5	22	54	42.5	41.5	53	16	50	23.5	M5 x 0.8	108	48.5	75.5	M5 x 0.8	8
REAH25	125	29	24	63	46	46	61.5	25	58.5	28	M6 x 1.0	138	56	86	M6 x 1.0	10

Model	N	NL	NT	P	PA	PB	PP	S	TW	W	XB	Z	ZZ
REAH15	16.5	15	8	M5 x 0.8	50	62	21	161	65	88.5	—	194	17.5
REAH20	18	15	8	Rc 1/8	50	65	23	169	70	92.5	—	205	19.5
REAH25	20.5	18	9	Rc 1/8	65	75	27	209	75	103	9.5	250	23.5

Max. Speed  
300  
mm/s

Basic Type  
REA

Direct Mount Type  
REAR

Slider Type/Slide Bearing  
REAS

Slider Type/Ball Bushing  
REAL

High Precision Guide Type  
REAH

Max. Speed  
600  
mm/s

Direct Mount Type  
REBR

High Precision Guide Type  
REBH

Auto Switches

Order Made

# Series REAH

Dimensions/ $\phi 25, \phi 32$

Dual axis type/REAHT

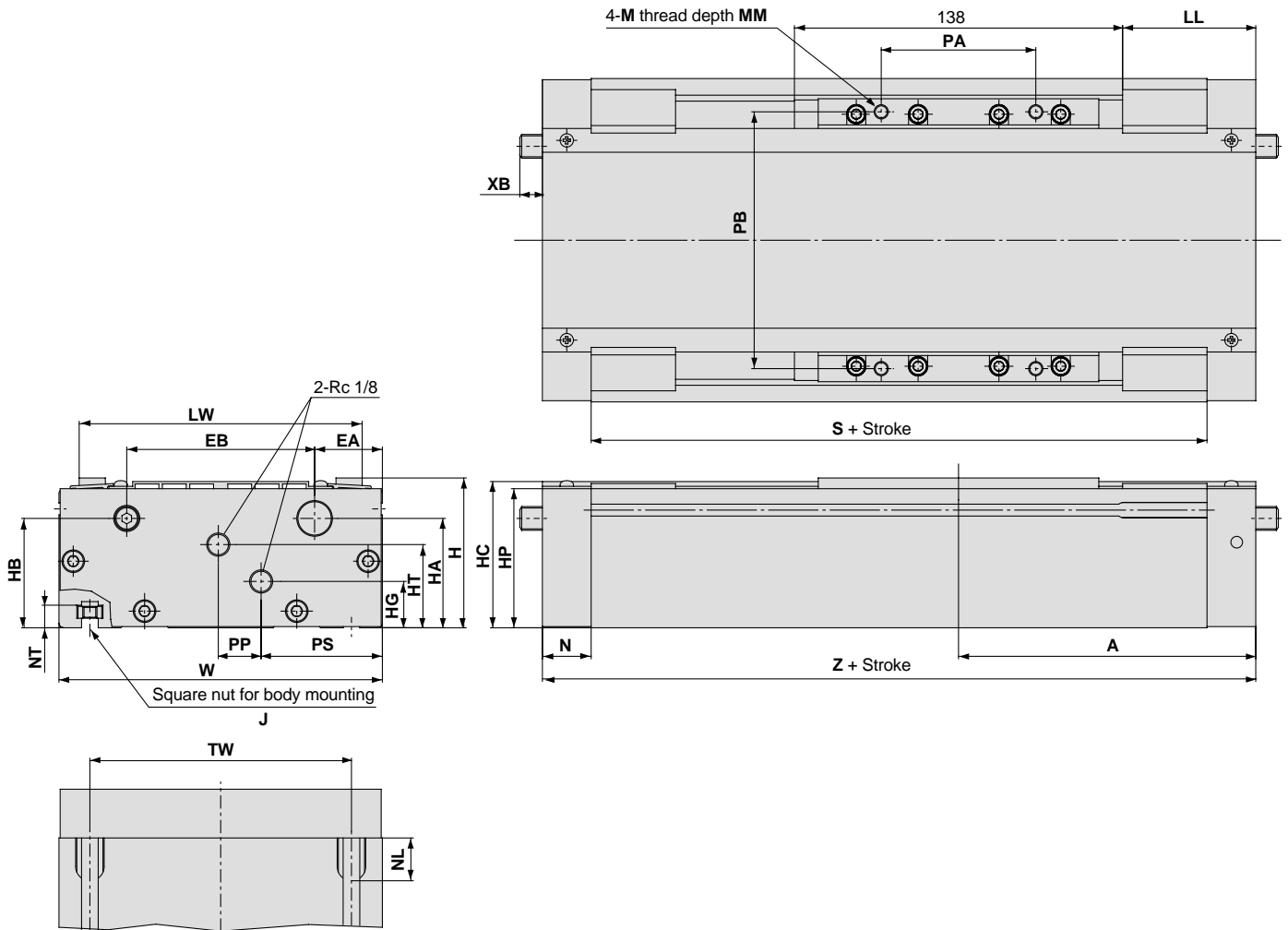

Model	A	EA	EB	H	HA	HB	HC	HG	HP	HT	J	LL	LW	M	MM	N
REAHT25	125	28.5	79	63	46	46	61.5	19.5	58.5	35	M6 x 1.0	56	119	M6 x 1.0	10	20.5
REAHT32	132.5	30	90	75	52.5	57.5	72.5	25	69.5	43	M8 x 1.25	63.5	130	M8 x 1.25	12	23

Model	NL	NT	PA	PB	PP	PS	S	TW	W	XB	Z
REAHT25	18	9	65	108	18	51	209	110	136	9.5	250
REAHT32	22.5	12	66	115	14	61	219	124	150	2	265

## Proper Auto Switch Mounting Position for Stroke End Detection

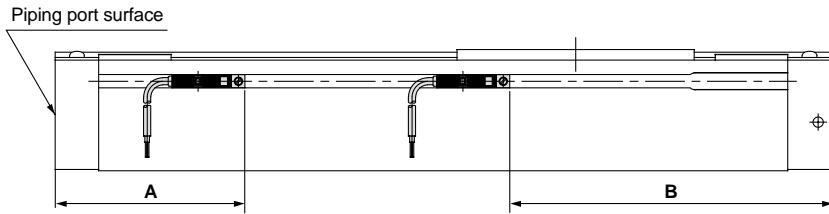

## Auto switch operating range

Auto switch model	(mm)	
	D-Z7□ D-Z80	D-Y7□W D-Y7□WV D-Y6□ D-Y7P D-Y7PV
Cylinder model		
REAH10	8	6
REAH15	6	5
REAH20	6	5
REAH25	6	5
REAH25	6	5
REAH32	9	6

Note) Operating ranges are standards including hysteresis, and are not guaranteed. Large variations may occur depending on the surrounding environment. (variations on the order of ±30%)

## Proper auto switch mounting position

Auto switch model	A			B		
	D-Z7□ D-Z80	D-Y7□W D-Y7□WV	D-Y5□ D-Y6□ D-Y7P D-Y7PV	D-Z7□ D-Z80	D-Y7□W D-Y7□WV	D-Y5□ D-Y6□ D-Y7P D-Y7PV
Cylinder model						
REAH10	65.5	65.5	65.5	59.5	59.5	59.5
REAH15	72	72	72	122	122	122
REAH20	77.5	77.5	77.5	127.5	127.5	127.5
REAH25	86	86	86	164	164	164
REAH25	86	86	86	164	164	164
REAH32	82	82	82	183	183	183

## Auto Switch Mounting

When mounting auto switches, they should be inserted into the cylinder's switch groove from the direction shown in the drawing on the right. After setting in the mounting position, use a flat head watchmakers screw driver to tighten the set screw which is included.

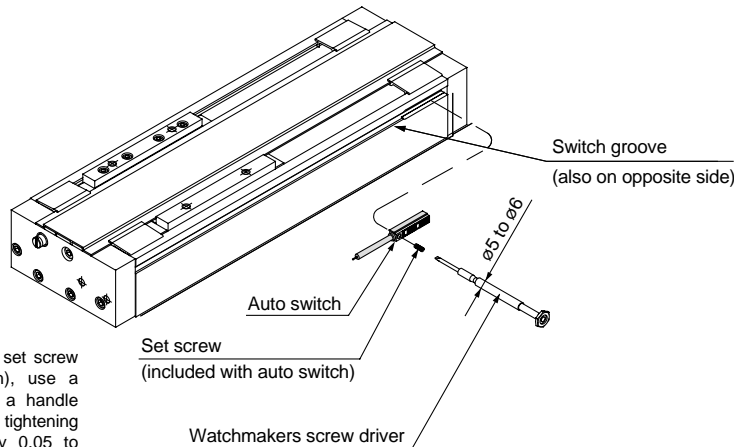

Note) When tightening the auto switch set screw (included with the auto switch), use a watchmakers screw driver with a handle about 5 to 6mm in diameter. The tightening torque should be approximately 0.05 to 0.1N·m.

## Auto Switch Lead Wire Containment Groove

On models REAH20 and REAH25 a groove is provided on the side of the body (one side only) to contain auto switch lead wires. This should be used for placement of wiring.

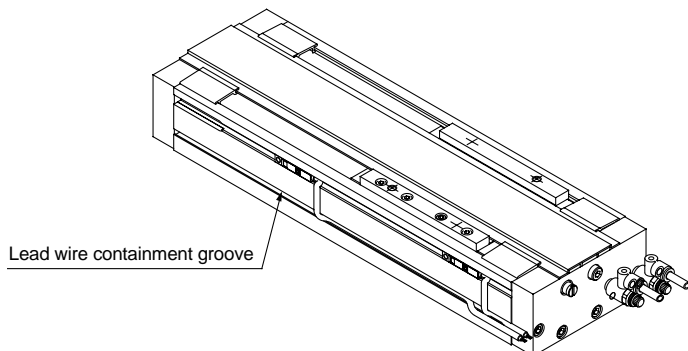

Max. Speed  
300  
mm/s

Basic Type  
Type  
REAH

Direct Mount Type  
Type  
REAR

Slider Type/Slide Bearing  
Type  
REAS

Slider Type/Ball Bushing  
Type  
REAL

High Precision Guide Type  
Type  
REAH

High Precision Guide Type  
Type  
REAH

Max. Speed  
600  
mm/s

Direct Mount Type  
Type  
REBR

High Precision Guide Type  
Type  
REBH

Auto Switches

Order Made

# Series REBR

## Direct Mount Type/ø15, ø25, ø32

### How to Order

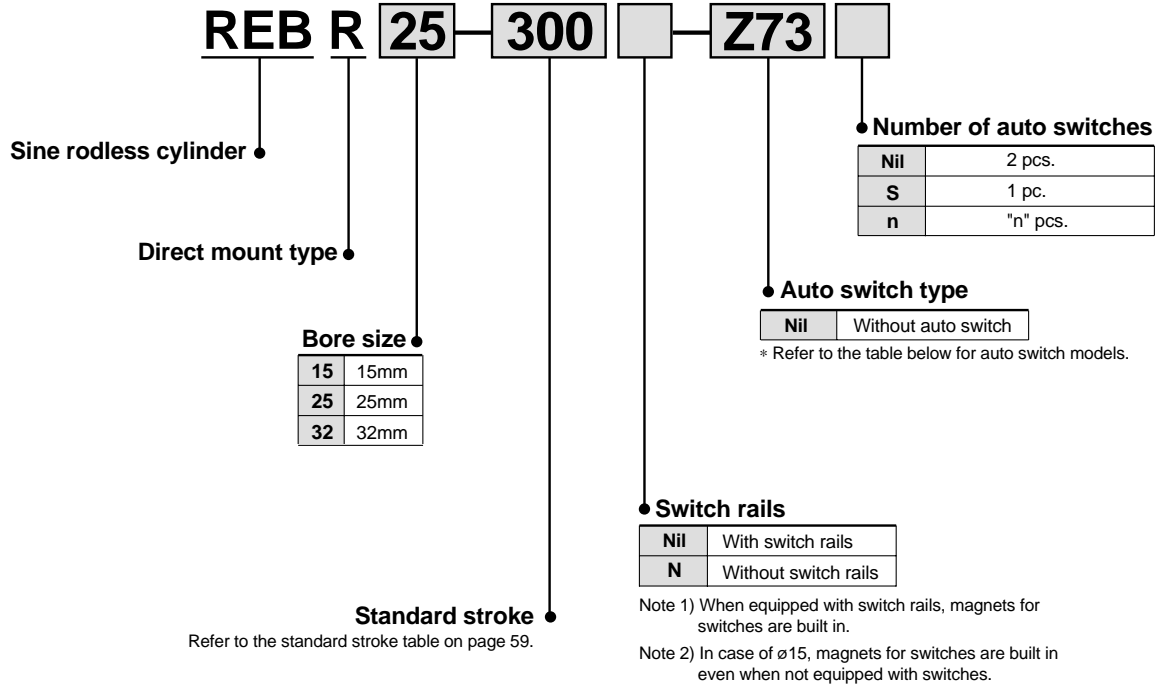

**Applicable auto switches** / Refer to "Auto Switch Guide" (E274-A) for further details on auto switch units.  
**For ø15** / Refer to pages 84 and 85 for auto switch circuit diagrams.

Type	Special function	Electrical entry	Indicator light	Wiring (output)	Load voltage			Auto switch model	Lead wire length (m) <sup>Note 1)</sup>			Applicable load	
					DC	AC			0.5 (Nil)	3 (L)	5 (Z)		
Reed switch	-	Grommet	No	2 wire	24V	5, 12V	100V or less	A90	●	●	-	IC circuit	Relay, PLC
			Yes			12V	100V	A93	●	●	-	-	
			3 wire (NPN equiv.)	-	5V	-	A96	●	●	-	IC circuit	-	
Solid state switch	-	Grommet	Yes	3 wire (NPN)	24V	12V	-	F9N	●	●	-	-	Relay, PLC
				3 wire (PNP)				F9P	●	●	-		
				2 wire				F9B	●	●	-		

Note 1) Lead wire length symbol 0.5m ..... Nil (Example) F9N  
3m ..... L F9NL

### For ø25, ø32

Type	Special function	Electrical entry	Indicator light	Wiring (output)	Load voltage			Auto switch model	Lead wire length (m) <sup>Note 1)</sup>			Applicable load	
					DC	AC			0.5 (Nil)	3 (L)	5 (Z)		
Reed switch	-	Grommet	Yes	3 wire	24V	12V	100V	Z76	●	●	-	IC circuit	-
				2 wire				Z73	●	●	●	-	
			No	5, 12V	100V or less	Z80	●	●	-	IC circuit	-		
Solid state switch	-	Grommet	Yes	3 wire (NPN)	24V	12V	-	Y59A	●	●	○	IC circuit	Relay, PLC
				3 wire (PNP)				Y7P	●	●	○	-	
				2 wire				Y59B	●	●	○	-	
				3 wire (NPN)				Y7NW	●	●	○	IC circuit	
				3 wire (PNP)				Y7PW	●	●	○	-	
				2 wire				Y7BW	●	●	○	-	

Note 1) Lead wire length symbol 0.5m ..... Nil (Example) Y59A  
3m ..... L Y59AL  
5m ..... Z Y59AZ

Note 2) Solid state auto switches marked with a "○" are produced upon receipt of order.



## Specifications

Fluid	Air
Proof pressure	1.05MPa
Maximum operating pressure	0.7MPa
Minimum operating pressure	0.18MPa
Ambient and fluid temperature	-10 to 60°C
Piston speed	50 to 600mm/s
Lubrication	Non-lube
Stroke length tolerance	0 to 250st: ${}^{+1.0}_0$ , 251 to 1000st: ${}^{+1.4}_0$ , 1001st and up: ${}^{+1.8}_0$
Mounting	Direct mount type

## Standard Strokes

Bore size (mm)	Standard stroke (mm)	Maximum manufacturable stroke (mm)	Maximum stroke with switch (mm)
15	150, 200, 250, 300, 350, 400 450, 500	1000	750
25	200, 250, 300, 350, 400, 450	2000	1500
32	500, 600, 700, 800		

Note) Intermediate strokes can be arranged in 1mm increments.

## Magnetic Holding Force

Bore size (mm)	15	25	32
Holding force	137	363	588

(N)

## Weights

Item	Bore size (mm)	(kg)		
		15	25	32
Basic weight (for 0st)	REBR□ (with switch rail)	0.277	0.660	1.27
	REBR□-□N (without switch rail)	0.230	0.580	1.15
Additional weight per 50mm stroke (when equipped with switch rail)		0.045	0.083	0.113
Additional weight per 50mm stroke (when not equipped with switch rail)		0.020	0.050	0.070

Calculation method/Example: REBR25-500 (with switch rail)

Basic weight ... 0.660kg, Additional weight ... 0.083kg/50mm, Cylinder stroke ... 500mm  
 $0.660 + 0.083 \times 500 \div 50 = 1.49\text{kg}$

Max. Speed  
300  
mm/s

Basic Type  
REAR

Direct Mount Type  
REAR

Slider Type/Slide Bearing  
REAS

Slider Type/Ball Bushing  
REAL

High Precision Guide Type  
REAH

Max. Speed  
600  
mm/s

Direct Mount Type  
REBR

High Precision Guide Type  
REBH

Auto Switches

Order Made

## ⚠ Specific Product Precautions

Be sure to read before handling. Refer to pages 92 through 94 for safety instructions and actuator precautions.

### Mounting

#### ⚠ Caution

1. Take care to avoid nicks or other damage on the outside surface of the cylinder tube.

This can lead to a damage of the scraper and wear ring, which in turn can cause malfunction.

2. Pay attention to the rotation of the external slider.

Rotation should be controlled by connecting it to another shaft (linear guide, etc.).

3. Do not operate with the magnetic coupling out of position.

In case the magnetic coupling is out of position, push the external slider back into the correct position by hand at the end of the stroke (or correct the piston slider with air pressure).

4. The cylinder is mounted with bolts through the mounting holes in the end covers. Be sure they are tightened securely.

5. Be sure that both end covers are secured to the mounting surface before operating the cylinder.

Avoid operation with the external slider secured to the surface.

6. Do not apply a lateral load to the external slider.

When a load is mounted directly to the cylinder, variations in the alignment of each shaft center cannot be offset, which results in the generation of a lateral load that can cause malfunction. The cylinder should be operated using a connection method which allows for shaft alignment variations and deflection due to the cylinder's own weight. A drawing of a recommended mounting is shown in Figure 2.

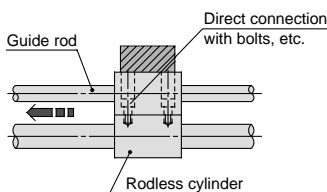

Variations in the load and cylinder shaft alignment cannot be offset and may result in a malfunction.

Figure 1.  
Incorrect mounting

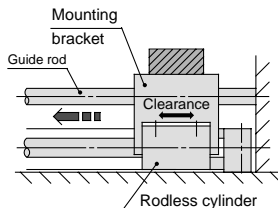

Shaft alignment variations are offset by providing clearance between the mounting bracket and cylinder. Moreover, the mounting bracket is extended above the cylinder shaft center, so that the cylinder is not subjected to moment.

Figure 2.  
Recommended mounting

7. Use caution regarding the allowable load weight when operating in a vertical direction.

The allowable load weight when operating in a vertical direction (reference values on page 63) is determined by the model selection method. However, if a load greater than the allowable value is applied, the magnetic coupling may break and there is a possibility of dropping the load. When using this type of application, contact SMC regarding the operating conditions (pressure, load, speed, stroke, frequency, etc.).

### Disassembly & Maintenance

#### ⚠ Caution

1. Special tools are necessary for disassembly.

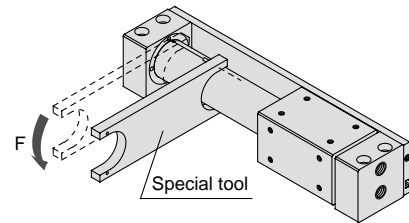

#### Special tool number list

No.	Applicable bore size (mm)
CYRZ-V	15
CYRZ-W	25, 32



# Series REBR Model Selection 1

**F<sub>n</sub>**: Allowable driving force (N)  
**M<sub>d</sub>**: Maximum allowable moment when connection fitting, etc., is directly loaded (N·m)  
**P<sub>v</sub>**: Maximum operating pressure for vertical operation (MPa)  
**W<sub>Bmax</sub>**: Maximum load weight when loaded directly on the body (kg)  
**W<sub>v</sub>**: Allowable load weight for vertical operation (kg)

**Operating conditions**

- **W**: Load weight (kg)
- **W<sub>B</sub>**: Connection fitting weight (kg)
- **μ**: Guide's coefficient of friction
- **L<sub>o</sub>**: Distance from cylinder shaft center to work piece point of application (cm)
- **L<sub>1</sub>**: Distance from cylinder shaft center to center of gravity of connection fitting, etc. (mm)
- **Presence of switches**
- **P**: Operating pressure (MPa)
- **U**: Maximum Speed (mm/s)
- **Stroke (mm)**
- **Mode of operation (horizontal, inclined, vertical)**

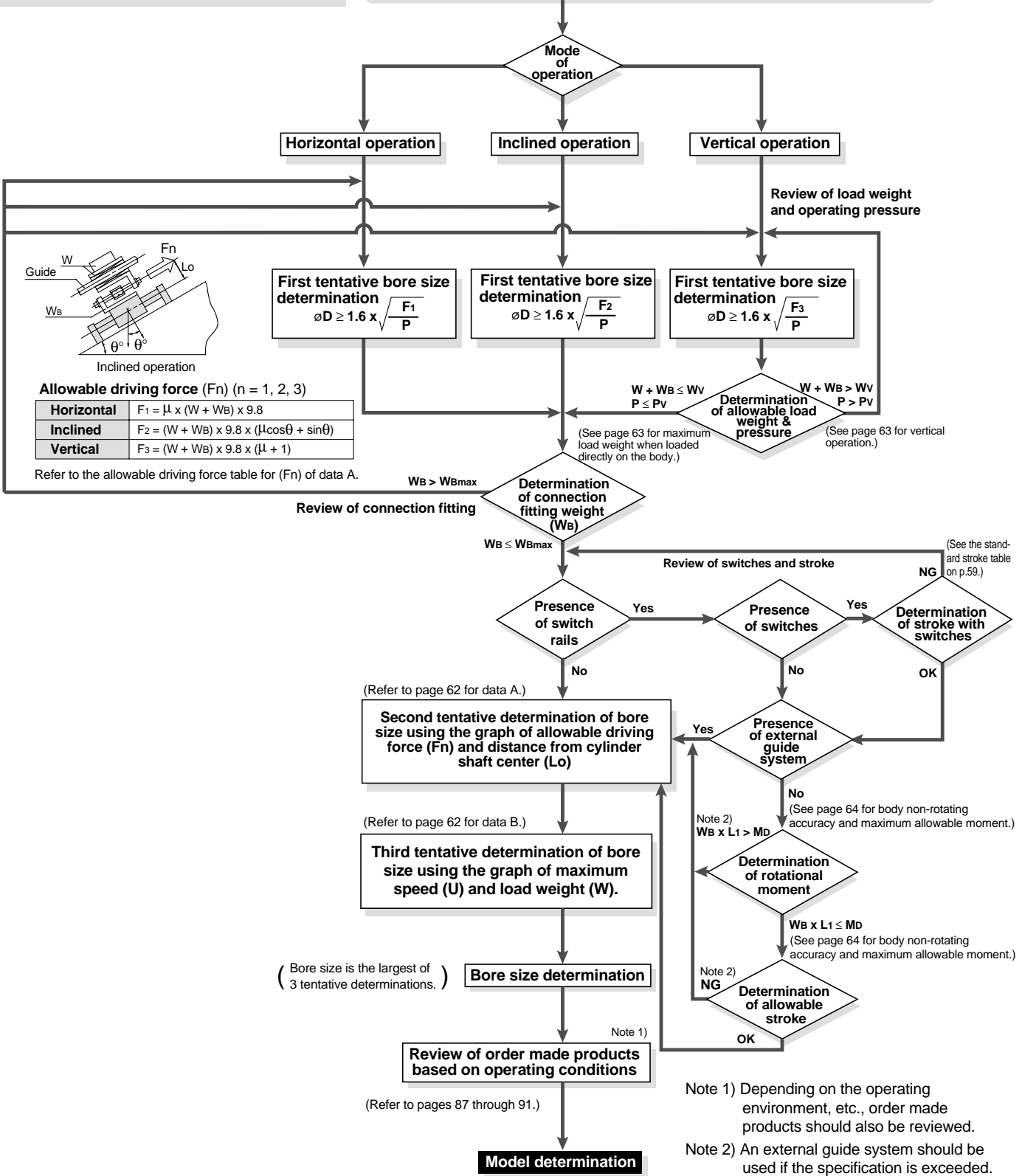

Max. Speed  
300  
mm/s

Basic Type  
REAR

Direct Mount Type  
REAR

Slider Type/Slide Bearing  
REAR

Slider Type/Ball Bushing  
REAL

High Precision Guide Type  
REAR

Max. Speed  
600  
mm/s

Direct Mount Type  
REBR

High Precision Guide Type  
REBH

Auto Switches

Order Made

61

# Series REBR Model Selection 2

## Design Parameters 1

### Selection Method

<Data A: Distance from cylinder shaft center — Allowable driving capacity>

REBR15

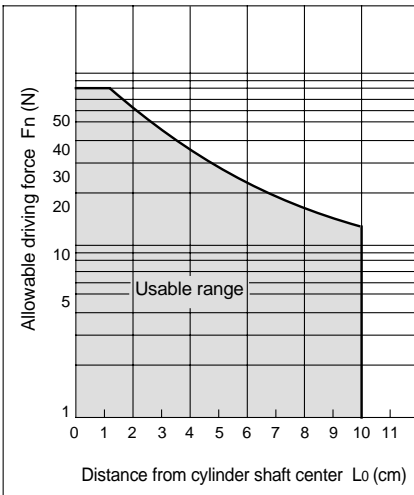

REBR25

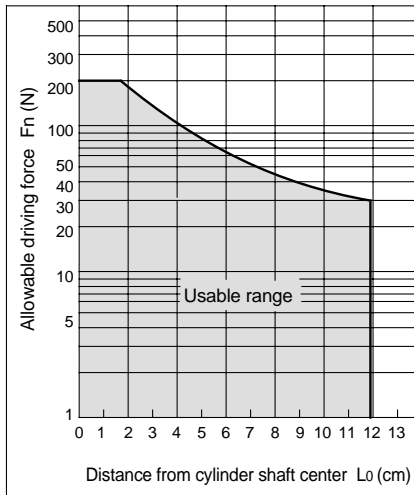

REBR32

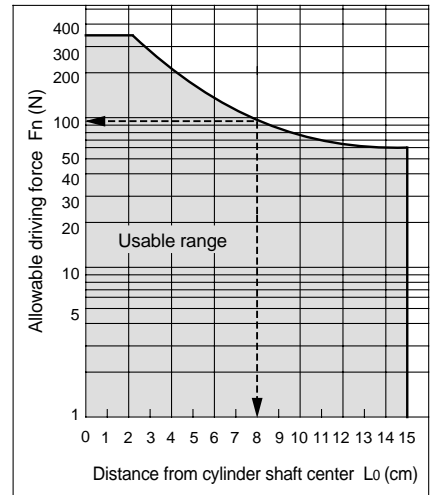

<Data B: Maximum speed — Load weight chart >

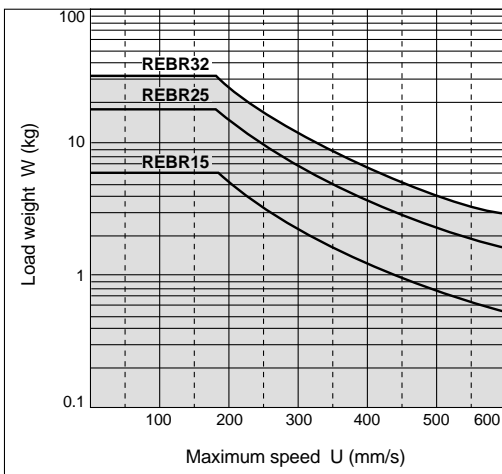

# Series REBR Model Selection 3

## Design Parameters 2

### Cylinder Self Weight Deflection

When the cylinder is mounted horizontally, deflection appears due to its own weight as shown in the data, and the longer the stroke, the greater the amount of variation in the shaft centers. Therefore, a connection method should be considered which allows for this variation as shown in the drawing.

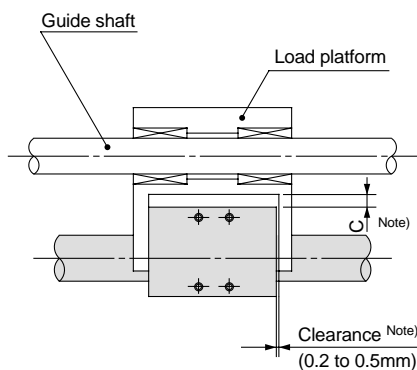

Note) Referring to the self weight deflection in the figure below, provide clearance so that the cylinder is able to operate smoothly through the full stroke within the minimum operating pressure range, without touching the mounting surface or the load, etc.

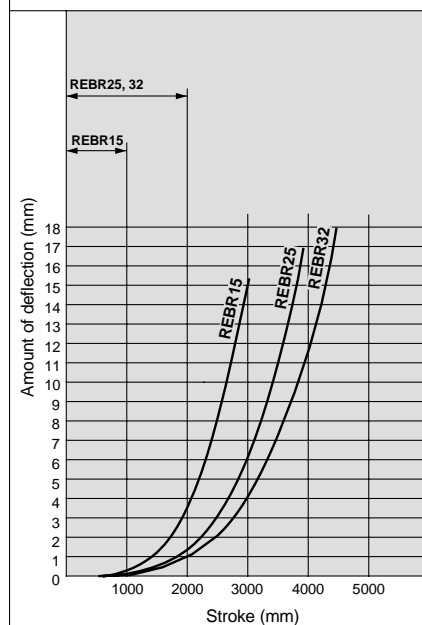
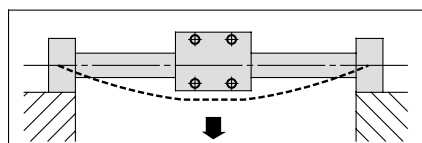

\* The above deflection data indicate values when the external slider has moved to the middle of the stroke.

### Vertical Operation

The load should be guided by a ball type bearing (LM guide, etc.). If a slide bearing is used, sliding resistance will increase due to the load weight and moment, and this can cause malfunction.

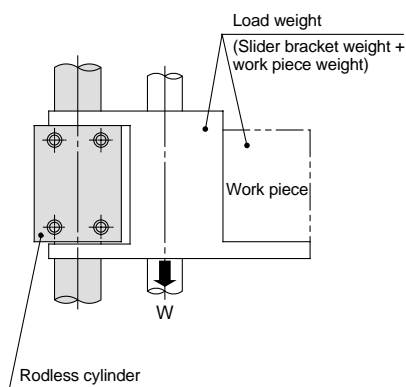

Cylinder bore size (mm)	Model	Allowable load weight $W_v$ (kg)	Max. operating pressure $P_v$ (MPa)
15	REBR15	7.0	0.65
25	REBR25	18.5	0.65
32	REBR32	30.0	0.65

Note) Use caution, as operation above the maximum operating pressure can result in breaking of the magnetic coupling.

### Maximum Load Weight when Loaded Directly on Body

When the load is applied directly to the body, it should be no greater than the maximum values shown in the table below.

Model	Maximum load weight $W_{max}$ (kg)
REBR 15	1.0
REBR 25	1.2
REBR 32	1.5

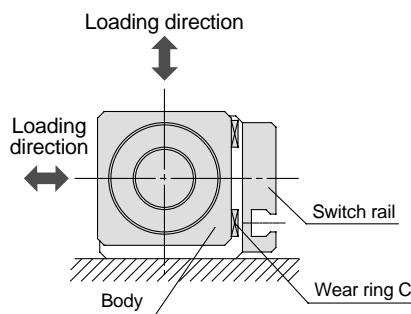

Max. Speed  
300  
mm/s

Basic Type  
REA

Direct Mount Type  
REAR

Slider Type/Slide Bearing  
REAS

Slider Type/Ball Bushing  
REAL

High Precision Guide Type  
REAH

Max. Speed  
600  
mm/s

Direct Mount Type  
REBR

High Precision Guide Type  
REBH

Auto Switches

Order Made

# Series REBR Model Selection 4

## Design Parameters 3

### Intermediate Stops

The cushion effect (smooth start-up, soft stop) exists only before the stroke in the stroke ranges indicated in the table below.

The cushion effect (smooth start-up, soft stop) cannot be obtained in an intermediate stop or a return from an intermediate stop using an external stopper, etc.

#### Cushion Stroke

Model	Stroke (mm)
REBR15	25
REBR25	30
REBR32	30

### Body Non-rotating Accuracy and Maximum Allowable Moment (with Switch Rail) (Reference Values)

Reference values for non-rotating accuracy and maximum allowable moment at stroke end are indicated below.

Bore size (mm)	Non-rotating accuracy (°)	Max. allowable moment (Mb) (N·m)	Allowable stroke (mm) <sup>Note 2)</sup>
15	4.5	0.15	200
25	3.7	0.25	300
32	3.1	0.40	400

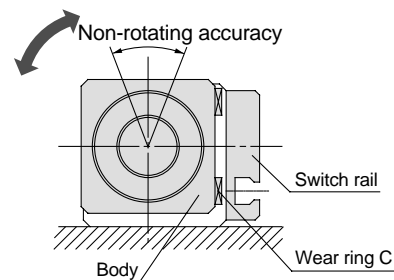

Note 1) Avoid operations where rotational torque (moment) is applied. In such a case, the use of an external guide is recommended.

Note 2) The above reference values will be satisfied within the allowable stroke ranges. However, caution is necessary because as the stroke becomes longer the inclination (rotation angle) within the stroke can be expected to increase.

Note 3) When a load is applied directly to the body, the loaded weight should be no greater than the allowable load weights on page 63.

**Construction/ø15, ø25, ø32**

Max. Speed  
300  
mm/s

Basic Type  
REA

Direct Mount Type  
REAR

Slider Type/Slide Bearing  
REAS

Slider Type/Ball Bushing  
REAL

High Precision Guide Type  
REAH

Max. Speed  
600  
mm/s

Direct Mount Type  
REBR

High Precision Guide Type  
REBH

Auto Switches

Order Made

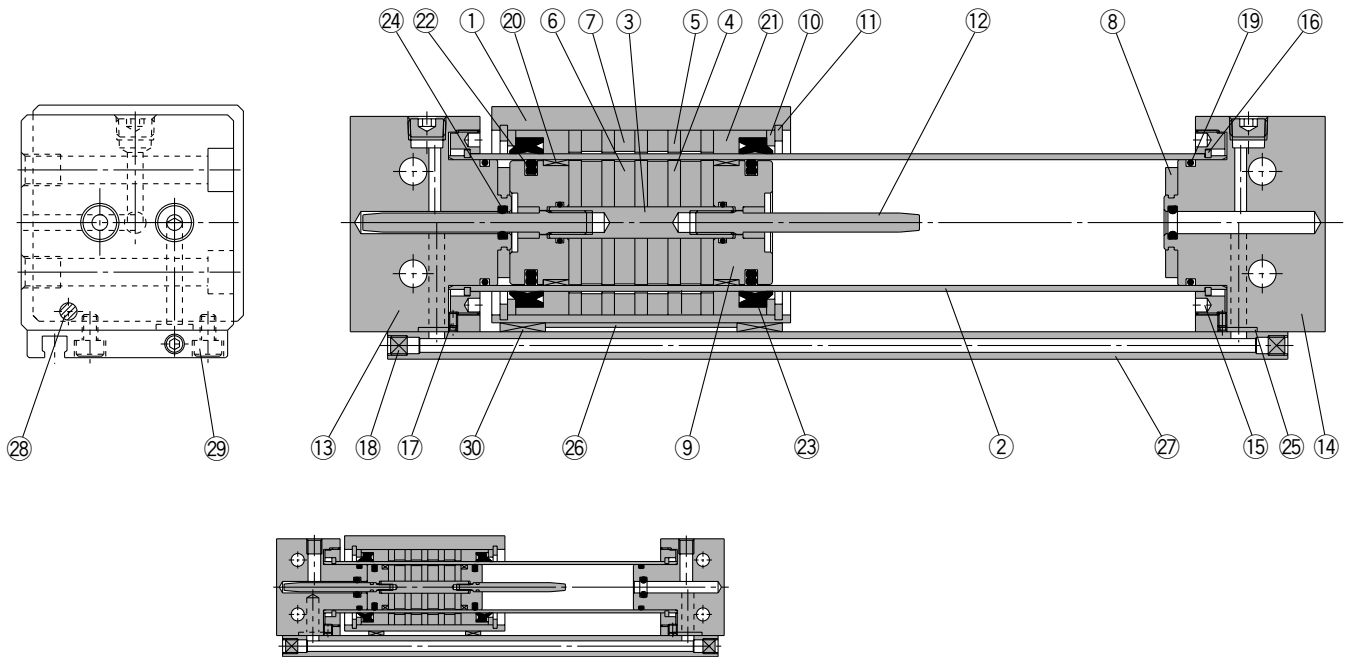

**REBR15**

**Parts list**

No.	Description	Material	Note
1	Body	Aluminum alloy	Hard anodized
2	Cylinder tube	Stainless steel	
3	Shaft	Stainless steel	
4	Piston side yoke	Rolled steel plate	Zinc chromated
5	External slider side yoke	Rolled steel plate	Zinc chromated
6	Magnet A	Rare earth magnet	
7	Magnet B	Rare earth magnet	
8	Bumper	Urethane rubber	Except REBR15
9	Piston	Aluminum alloy	Chromated
10	Spacer	Rolled steel plate	Nickel plated
11	Snap ring	Carbon tool steel	Nickel plated
12	Cushion ring	Stainless steel	REBR15, 25 Compound electroless nickel plated
		Brass	REBR32
13	End cover A	Aluminum alloy	Hard anodized
14	End cover B	Aluminum alloy	Hard anodized
15	Attachment ring	Aluminum alloy	Hard anodized
16	C type snap ring for shaft	Hard steel wire	Nickel plated (REBR15)
		Stainless steel	REBR25,32
17	Hexagon socket head set screw	Chromium steel	Nickel plated
18	Hexagon socket head plug	Chromium steel	Nickel plated
19	Cylinder tube gasket	NBR	

**Parts list**

No.	Description	Material	Note
20	Wear ring A	Special resin	
21	Wear ring B	Special resin	
22	Piston seal	NBR	
23	Scraper	NBR	
24	Cushion seal	NBR	
25	Switch rail gasket	NBR	
26	Magnetic shielding plate	Rolled steel plate	Chromated
27	Switch rail	Aluminum alloy	Clear anodized
28	Magnet	Rare earth magnet	
29	Hexagon socket head screw	Chromium steel	Nickel plated
30	Wear ring C	Special resin	

**Replacement parts: Seal kits**

Bore size (mm)	Kit no.	Content
15	REBR15-PS	Above numbers 19, 20, 21, 22, 23, 24, 25, 30
25	REBR25-PS	
32	REBR32-PS	

**Switch Rail Accessory Kits**

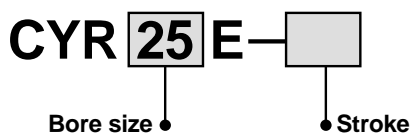

**Switch rail accessory kits**

Bore size (mm)	Kit no.	Content
15	CYR15E-□	Above numbers 26, 27, 28, 29, 30
25	CYR25E-□	
32	CYR32E-□	

Note 1) □ indicates the stroke.  
Note 2) ø15 has internal magnets in the body.

# Series REBR

## Dimensions/ø15, ø25, ø32

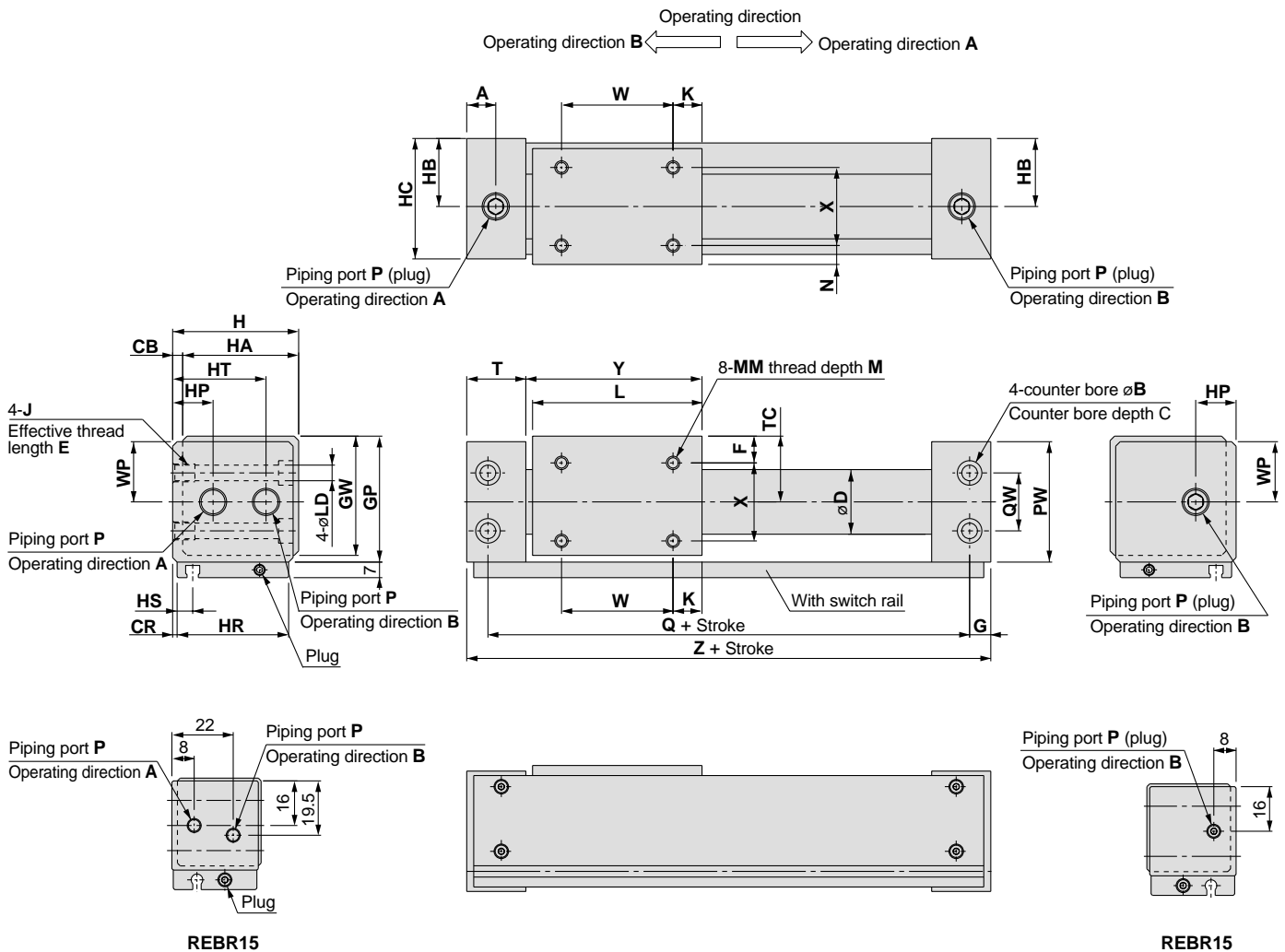

REBR15

REBR15

(mm)

Model	A	B	C	CB	CR	D	F	G	GP	GW	H	HA	HB	HC	HP	HR	HS	HT
REBR15	12.5	8	4.2	2	0.5	17	8	5	33	31.5	32	30	17	31	—	30	8.5	—
REBR25	12.5	9.5	5.2	3	1	27.8	8.5	10	44	42.5	44	41	23.5	43	14.5	41	6.5	23.5
REBR32	19.5	11	6.5	3	1.5	35	10.5	16	55	53.5	55	52	29	54	20	51	7	29

  

Model	J x E	K	L	LD	M	MM	N	P	PW	Q	QW	T	TC	W	WP
REBR15	M5 x 0.8 x 7	14	53	4.3	5	M4 x 0.7	6	M5 x 0.8	32	84	18	21	17	25	—
REBR25	M6 x 1 x 8	15	70	5.6	6	M5 x 0.8	6.5	Rc 1/8	43	105	20	25.5	22.5	40	21.5
REBR32	M8 x 1.25 x 10	13	76	7	7	M6 x 1	8.5	Rc 1/8	54	116	26	33	28	50	27

Model	X	Y	Z
REBR15	18	54.5	98
REBR25	28	72	125
REBR32	35	79	148

## Proper Auto Switch Mounting Position for Stroke End Detection

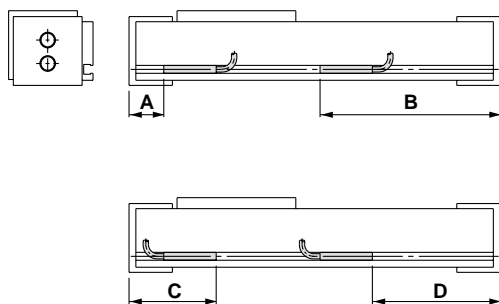

## Auto Switch Operation Range

Bore size (mm)	Auto switch model			
	D-A9□	D-F9□	D-Z7□ D-Z8□	D-Y5□ D-Y7□ D-Y7□W
15	8	5	—	—
25	—	—	9	7
32	—	—	9	6

Note 1) Switches cannot be mounted in some cases.

Note 2) Operating ranges are standards including hysteresis, and are not guaranteed. Large variations may occur depending on the surrounding environment (variation on the order of ±30%).

Auto switch model	Bore size (mm)							
	A		B		C		D	
Bore size (mm)	D-A9□	D-F9□	D-A9□	D-F9□	D-A9□	D-F9□	D-A9□	D-F9□
15	17.5	21.5	76.5	72.5	—	—	56.5	60.5

Note) Auto switches cannot be installed in Area C in the case of  $\phi 15$ .

Auto switch model	Bore size (mm)							
	A		B		C		D	
Bore size (mm)	D-Z7□ D-Z8□	D-Y5□ D-Y7□ D-Y7□W	D-Z7□ D-Z8□	D-Y5□ D-Y7□ D-Y7□W	D-Z7□ D-Z8□	D-Y5□ D-Y7□ D-Y7□W	D-Z7□ D-Z8□	D-Y5□ D-Y7□ D-Y7□W
25	22	22	101	103	47	47	78	78
32	30.5	30.5	117.5	117.5	55.5	55.5	92.5	92.5

## Auto Switch Mounting

When mounting auto switches, they should be inserted into the cylinder's switch groove from the direction shown in the drawing on the right. After setting in the mounting position, use a flat head watchmakers screw driver to tighten the mounting screw which is included.

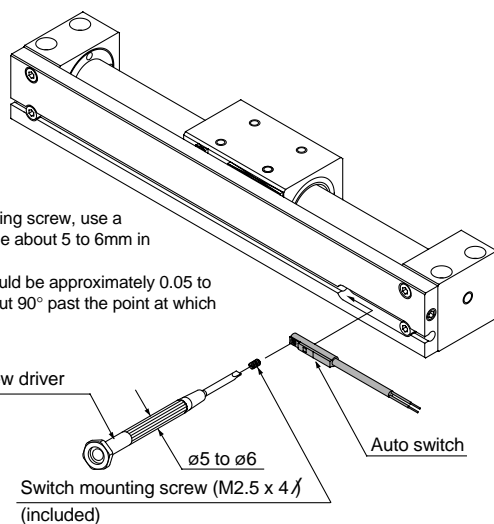

Note) When tightening the auto switch mounting screw, use a watchmakers screw driver with a handle about 5 to 6mm in diameter. Furthermore, the tightening torque should be approximately 0.05 to 0.1N·m. As a rule, it can be turned about 90° past the point at which tightening can be felt.

## Auto Switch Specifications

- (1) Switches (switch rail) can be added to the standard type (without switch rail). Switch rail accessory kits are mentioned on page 65 and can be ordered together with auto switches.
- (2) Refer to the separate disassembly instructions for switch magnet installation procedures.

Max. Speed  
300  
mm/s

Basic Type  
REAR

Direct Mount Type  
REAR

Slider Type/Slide Bearing  
REAR

Slider Type/Ball Bushing  
REAL

High Precision Guide Type  
REAR

Max. Speed  
600  
mm/s

Direct Mount Type  
REBR

High Precision Guide Type  
REBH

Auto Switches

Order Made

# Series *REBH* High Precision GuideType

## How to Order

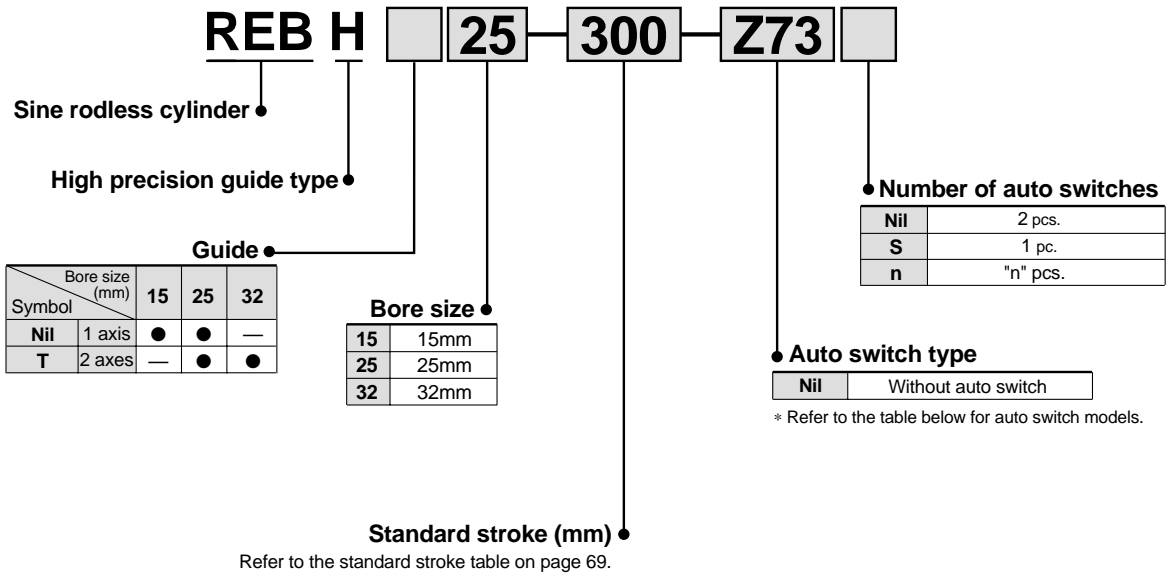

### Applicable auto switches

Refer to "Auto Switch Guide" (E-274-A) for further details on auto switch units.  
Refer to pages 84 and 85 for auto switch circuit diagrams.

Type	Special function	Electrical entry	Indicator light	Wiring (output)	Load voltage			Auto switch model		Lead wire length (m) <sup>Note 1)</sup>			Applicable load		
					DC		AC	Electrical entry direction		0.5 (Nil)	3 (L)	5 (Z)			
								Perpendicular	In-line						
Reed switches	—	Grommet	Yes	3 wire (NPN equiv.)	—	5V	—	—	Z76	●	●	—	IC circuit	—	
				2 wire	24V	12V	100V	—	Z73	●	●	●	—	Relay, PLC	
Solid state switches	Diagnostic indication (2 color indicator)	Grommet	Yes	3 wire (NPN)	24V	5V, 12V	100V or less	—	Y69A	Y59A	●	●	○	IC circuit	Relay, PLC
				3 wire (PNP)					Y7PV	Y7P	●	●	○	IC circuit	
				2 wire					Y69B	Y59B	●	●	○	—	
				3 wire (NPN)					Y7NWV	Y7NW	●	●	○	IC circuit	
				3 wire (PNP)					Y7PWV	Y7PW	●	●	○	IC circuit	
				2 wire					Y7BWV	Y7BW	●	●	○	—	

Note 1) Lead wire length symbol  
 0.5m ..... Nil (Example) Y59A  
 3m ..... L (Example) Y59AL  
 5m ..... Z (Example) Y59AZ

Note 2) Solid state auto switches marked with a "○" are produced upon receipt of order.



Max. Speed  
300  
mm/s

## Specifications



Bore size (mm)	15	25	32
Fluid	Air		
Action	Double acting		
Maximum operating pressure	0.7MPa		
Minimum operating pressure	0.2MPa		
Proof pressure	1.05MPa		
Ambient and fluid temperature	-10 to 60°C		
Piston speed	70 to 600mm/s		
Lubrication	Non-lube		
Stroke length tolerance	0 to 1.8mm		
Piping type	Centralized piping		
Piping port size	M5 x 0.8	Rc 1/8	

Basic Type  
REAR

Direct Mount Type  
REAR

Slider Type/Slide Bearing  
REAS

Slider Type/Ball Bushing  
REAL

High Precision Guide Type  
REAH

## Standard Strokes

Bore size (mm)	Number of axes	Standard stroke (mm)	Maximum manufacturable stroke (mm)
15	1 axis	150, 200, 300, 400, 500	750
25		200, 300, 400, 500, 600, 800	1200
25	2 axes	200, 300, 400, 500, 600, 800, 1000	1500
32			

Note 1) Strokes exceeding the standard strokes are available as a special order.

Note 2) Intermediate strokes other than order made (refer to page 91 for XB10) are available by special order.

## Weights

(kg)

Model	Standard stroke mm							
	150	200	300	400	500	600	800	1000
REBH15	2.5	2.7	3.2	3.6	4.1	—	—	—
REBH25	—	5.3	6.0	6.6	7.3	8.0	9.4	—
REBHT25	—	6.2	7.3	8.3	9.4	10.4	12.5	14.6
REBHT32	—	9.6	10.7	11.9	13.0	14.2	16.5	18.8

Max. Speed  
600  
mm/s

Direct Mount Type  
REBR

High Precision Guide Type  
REBH

## Magnetic Holding Force

(N)

Bore size (mm)	15	25	32
Holding force	137	363	588

## Theoretical Output

(N)

Bore size (mm)	Piston area (mm <sup>2</sup> )	Operating pressure (MPa)					
		0.2	0.3	0.4	0.5	0.6	0.7
15	176	35	52	70	88	105	123
25	490	98	147	196	245	294	343
32	804	161	241	322	402	483	563

Note) Theoretical output (N) = Pressure (MPa) x Piston area (mm<sup>2</sup>).

Auto Switches

Order Made

## ⚠ Specific Product Precautions

Be sure to read before handling. Refer to pages 92 through 94 for safety instructions and actuator precautions.

### Mounting

#### ⚠ Caution

1. The interior is protected to a certain extent by the top cover, however, when performing maintenance, etc., take care not to cause scratches or other damage to the cylinder tube, slide table or linear guide by striking them or placing objects on them.

The bore and exterior of tubes are manufactured to precise tolerances, so that even a slight deformation can cause malfunction.

2. Since the slide table is supported by precision bearings, do not apply strong impacts or large moment, etc., when mounting work pieces.
3. **Mounting of the cylinder body**

The body is mounted using the square nuts, which are included, in the two T-slots on the bottom of the body. Refer to the table below for mounting bolt dimensions and tightening torque.

Model		REBH15	REBH25	REBH25	REBH32
Bolt dimensions	Screw size	M5 x 0.8	M6 x 1.0		M8 x 1.25
	Dimension t	∮8	∮9		∮12
Tightening torque	N·m	2.65	4.4		13.2

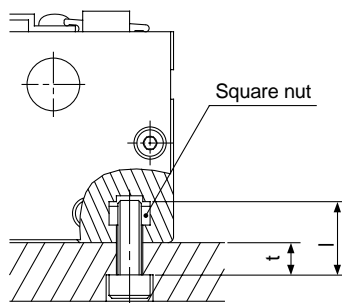

### Operation

#### ⚠ Caution

1. The unit can be used with a direct load within the allowable range, but when connecting to a load which has an external guide mechanism, careful alignment is necessary.

Since variation of the shaft center increases as the stroke becomes longer, a connection method should be devised which allows for this displacement.

2. Since the guide is adjusted at the time of shipment, unintentional movement of the adjustment setting should be avoided.
3. Contact SMC before operating in an environment where there will be contact with chips, dust (paper scraps, thread scraps, etc.) or cutting oil (gas oil, water, hot water, etc.).
4. **Do not operate with the magnetic coupling out of position.**

In case the magnetic coupling is out of position, push the external slider back into the correct position by hand at the end of the stroke (or correct the piston slider with air pressure).

# Series REBH Model Selection 1

**Pv**: Maximum operating pressure for vertical operation (MPa)  
**Wv**: Allowable load weight for vertical operation (kg)  
**α**: Load factor

$$\Sigma\alpha = \frac{\text{Load weight (W)}}{\text{Max. load weight (Wmax)}} + \frac{\text{Static moment (M)}}{\text{Allowable static moment (Mmax)}} + \frac{\text{Dynamic moment (Me)}}{\text{Allowable dynamic moment (Memax)}}$$

**Operating conditions**

- W: Load weight (kg)
- U: Maximum Speed (mm/s)
- P: Operating pressure (MPa)
- Stroke (mm)
- Position of work piece center of gravity (m)
- Mode of operation (horizontal, inclined, vertical)

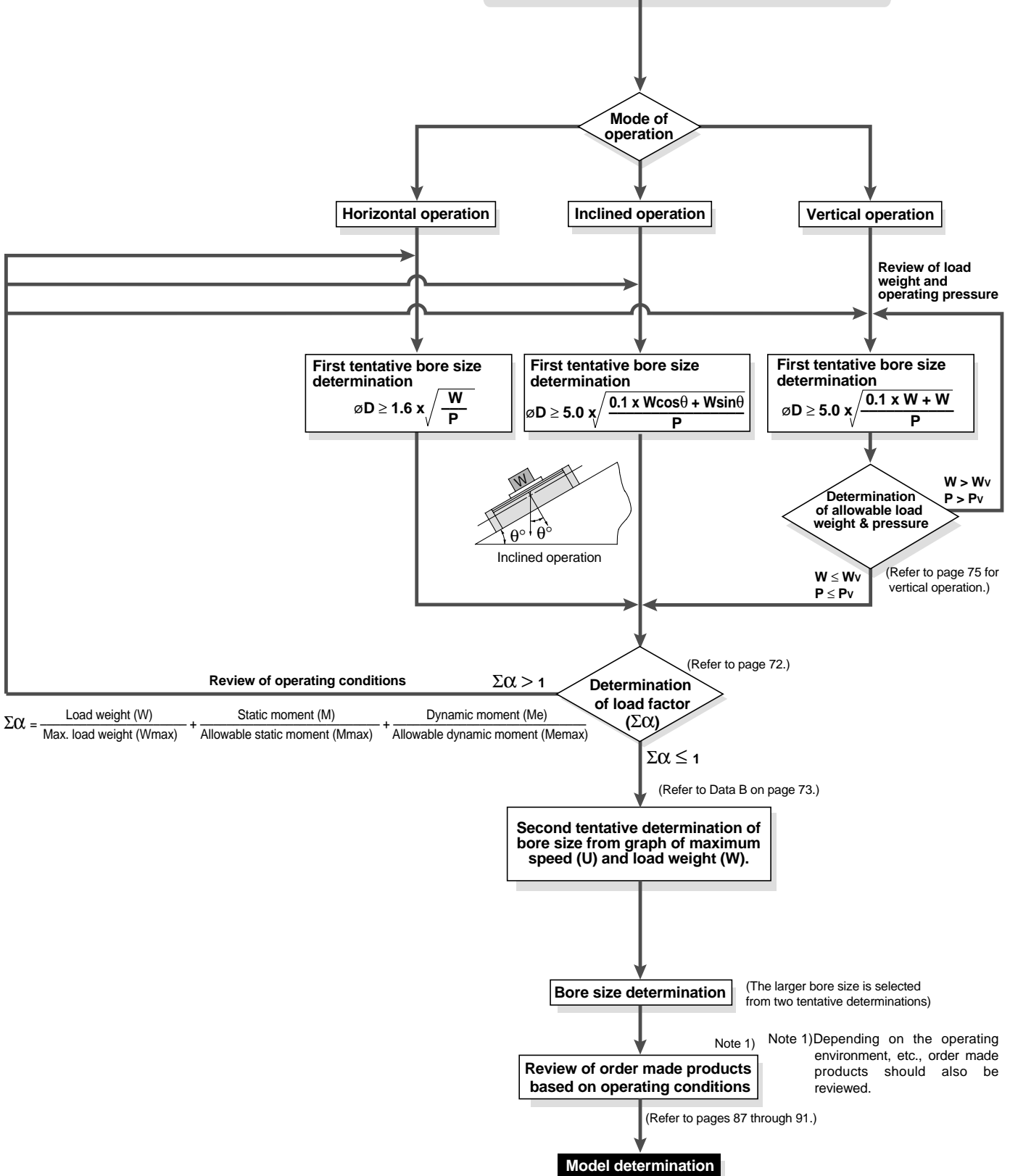

Max. Speed  
300  
mm/s

Basic Type  
REA

Direct Mount Type  
REAR

Slider Type/Slide Bearing  
REAS

Slider Type/Ball Bushing  
REAL

High Precision Guide Type  
REAH

Max. Speed  
600  
mm/s

Direct Mount Type  
REBR

High Precision Guide Type  
REBH

Auto Switches

Order Made

# Series REBH Model Selection 2

## Design Parameters 1

The maximum load weight and allowable moment will differ depending on the work piece mounting method, cylinder mounting orientation and piston speed.

A determination of suitability for use should be performed so that the total ( $\Sigma\alpha_n$ ) of the load factors ( $\alpha_n$ ) for each weight and moment does not exceed 1.

$$\Sigma\alpha_n = \frac{\text{Load weight (W)}}{\text{Max. load weight (Wmax)}} + \frac{\text{Static moment (M)}}{\text{Allowable static moment (Mmax)}} + \frac{\text{Dynamic moment (Me)}}{\text{Allowable dynamic moment (Memax)}} \leq 1$$

## Design Parameters

### Load weight

Max. load weight (kg)

Model	W <sub>max</sub>
REBH15	9
REBH25	25
REBHT25	25
REBHT32	40

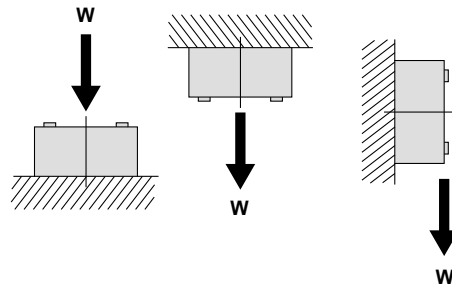

W

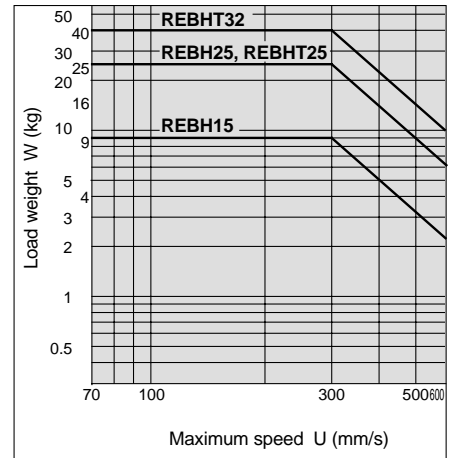

<Graph 1>

### Moment

Allowable moment

(Static moment/Dynamic moment)  
(N·m)

Model	M <sub>1</sub>	M <sub>2</sub>	M <sub>3</sub>
REBH15	10	16	10
REBH25	28	26	28
REBHT25	56	85	56
REBHT32	64	96	64

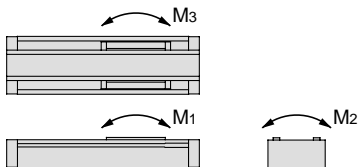

M1, M3

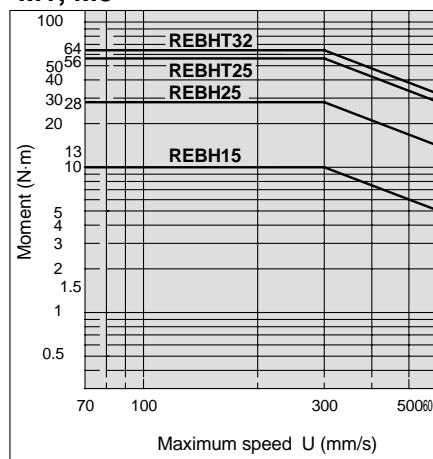

<Graph 2>

M2

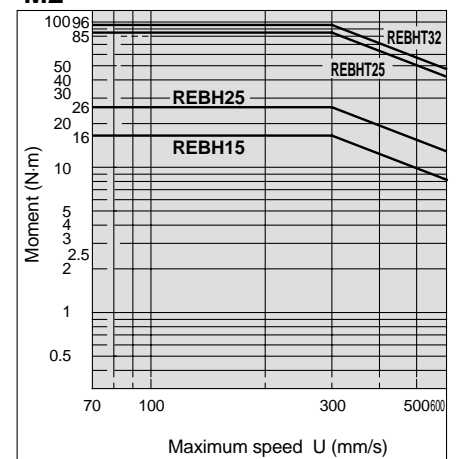

<Graph 3>

**Static moment**

Moment generated by the self weight of the load even when the cylinder is stopped

■ Pitch moment  
 $M_1 = W \cdot L$

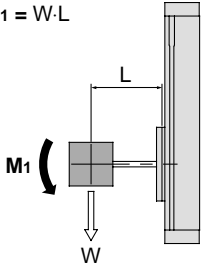

■ Roll moment  
 $M_2 = W \cdot L$

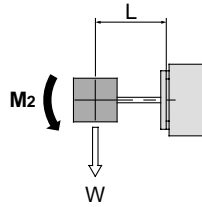

■ Yaw moment  
 $M_3 = W(L-A)$

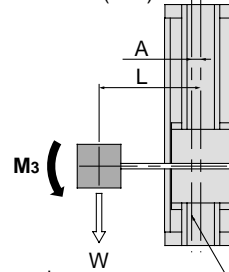

(mm)

Model	A
REBH15	17.5
REBH25	23.5
REBHT25	0*
REBHT32	0*

\* Since there are 2 guides, the guides' central axis and the cylinder's central axis are the same.

**Dynamic moment**

Moment generated by the load equivalent to the impact at the stroke end

$We = 5 \times 10^{-3} \cdot W \cdot g \cdot U$

- We: Load equivalent to impact [N]
- W: Load weight [kg]
- U: Maximum speed [mm/s]
- g: Gravitational acceleration (9.8m/s<sup>2</sup>)

■ Pitch moment  
 $Me_1 = 1/3 \cdot We \cdot L$

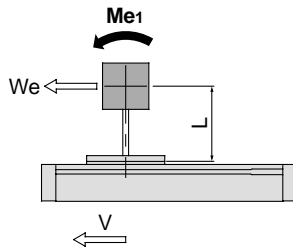

■ Yaw moment  
 $Me_3 = 1/3 \cdot We(L-A)$

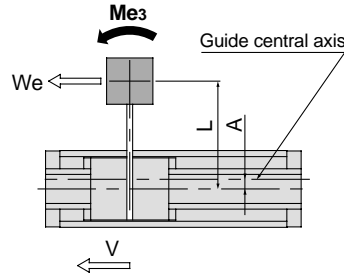

(mm)

Model	A
REBH15	17.5
REBH25	23.5
REBHT25	0*
REBHT32	0*

\* Since there are 2 guides, the guides' central axis and the cylinder's central axis are the same.

<Data B: Maximum speed Load weight chart>

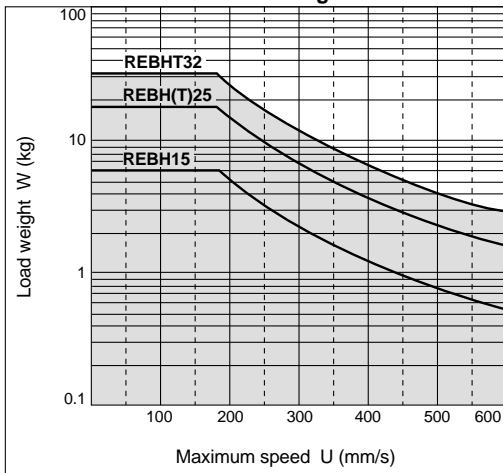

# Series REBH Model Selection 3

## Selection Calculation

The selection calculation finds the load factors ( $\alpha_n$ ) of the items below, where the total ( $\Sigma\alpha_n$ ) does not exceed 1.

$$\Sigma\alpha_n = \alpha_1 + \alpha_2 + \alpha_3 \leq 1$$

Item	Load factor $\alpha_n$	Note
1. Max. load weight	$\alpha_1 = W/W_{max}$	Review W. W <sub>max</sub> is the maximum load weight.
2. Static moment	$\alpha_2 = M/M_{max}$	Review M <sub>1</sub> , M <sub>2</sub> , M <sub>3</sub> . M <sub>max</sub> is the allowable moment.
3. Dynamic moment	$\alpha_3 = Me/M_{max}$	Review Me <sub>1</sub> , Me <sub>3</sub> . Me <sub>max</sub> is the allowable moment.

U: Maximum speed

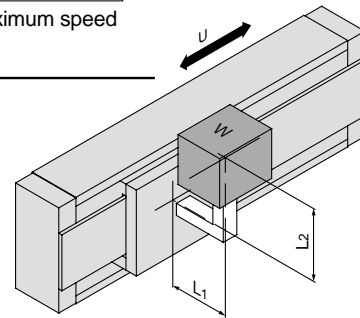

## Calculation examples

### Operating conditions

Cylinder: REBH15  
Mounting: Horizontal wall mounting  
Maximum speed: U = 500 [mm/s]  
Load weight: W = 1 [kg] (excluding weight of arm section)  
L1 = 200 [mm]  
L2 = 200 [mm]

Item	Load factor $\alpha_n$	Note
<b>1. Maximum load weight</b>	$\alpha_1 = W/W_{max}$ $= 1/3$ $= \mathbf{0.111}$ $= \mathbf{0.333}$	Review W. (For W <sub>max</sub> , find the value in <Graph 2> when U = 500mm/s.)
<b>2. Static moment</b>	$M_2 = W \cdot L_1$ $= 10 \cdot 0.2$ $= 2 \text{ [N}\cdot\text{m]}$ $\alpha_2 = M_2/M_2 \text{ max}$ $= 2/16$ $= \mathbf{0.125}$	Review M <sub>2</sub> . Since M <sub>1</sub> & M <sub>3</sub> are not generated, review is unnecessary.
<b>3. Dynamic moment</b>	$We = 5 \times 10^{-3} \cdot W \cdot g \cdot U$ $= 5 \times 10^{-3} \cdot 1.9.8 \cdot 500$ $= 25 \text{ [N]}$ $Me_3 = 1/3 \cdot We(L_2 - A)$ $= 1/3 \cdot 25 \cdot 0.182$ $= 1.52 \text{ [N}\cdot\text{m]}$ $\alpha_3 = Me_3/Me_3 \text{ max}$ $= 1.52/6$ $= \mathbf{0.25}$	Review Me <sub>3</sub> . (For Me <sub>max</sub> , find the value in <Graph 2> when U = 500mm/s.)
	$Me_1 = 1/3 \cdot We \cdot L_1$ $= 1/3 \cdot 25 \cdot 0.2$ $= 1.6 \text{ [N}\cdot\text{m]}$ $\alpha_4 = Me_1/Me_1 \text{ max}$ $= 1.6/6$ $= \mathbf{0.27}$	Review Me <sub>1</sub> . (For Me <sub>max</sub> , find the value in <Graph 2> when U = 500mm/s.)

$$\begin{aligned} \Sigma\alpha_n &= \alpha_1 + \alpha_2 + \alpha_3 + \alpha_4 \\ &= 0.333 + 0.125 + 0.25 + 0.27 \\ &= 0.978 \quad \text{Can be used based on } \Sigma\alpha_n = 0.978 \leq 1. \end{aligned}$$

# Series REBH Model Selection 4

## Design Parameters 2

### Table Deflection

Table deflection due to pitch moment load

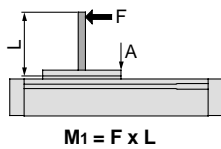

REBH15, 25

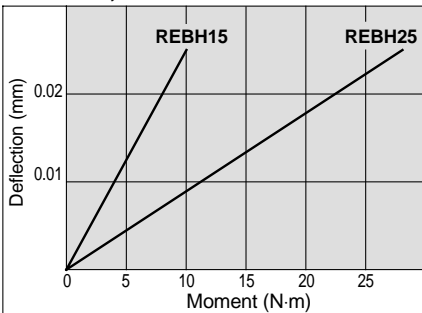

REBHT25, 32

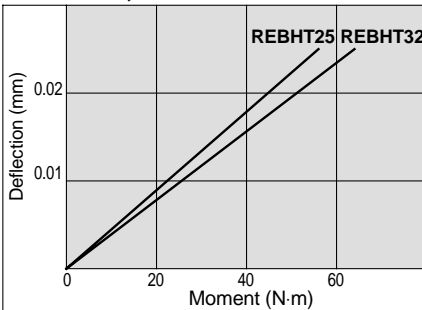
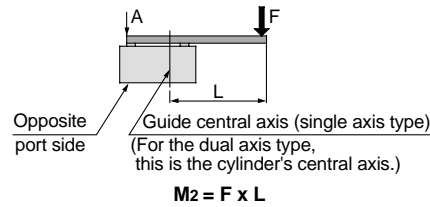
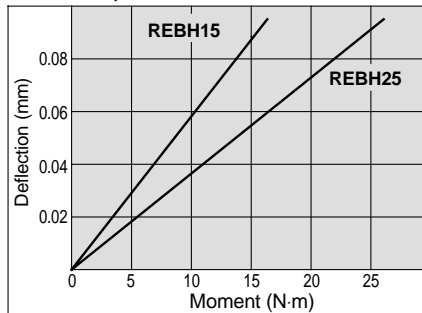

Table deflection due to roll moment load



REBH15, 25



REBHT25, 32

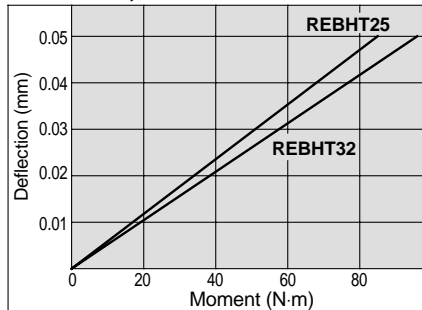
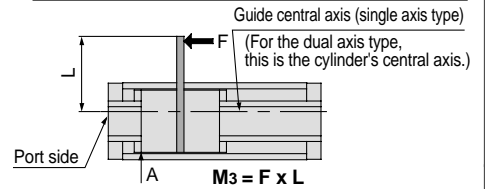
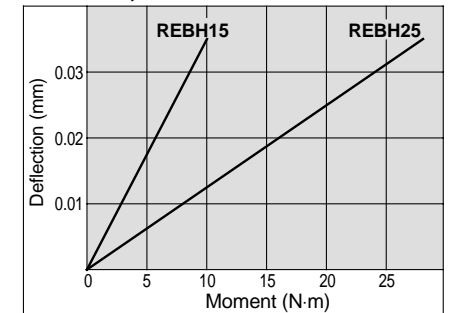

Table deflection due to yaw moment load



REBH15, 25



REBHT25, 32

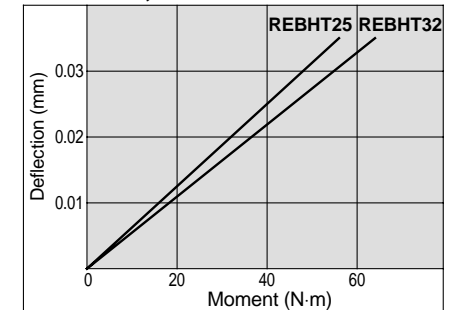

Note) Deflection: Displacement of section A when force acts on section F

### Vertical Operation

When using in vertical operation, prevention of work piece dropping due to breaking of the magnetic coupling should be considered. The allowable load weight and maximum operating pressure should be as shown in the table below.

Model	Allowable load weight Wv (kg)	Max. operating pressure Pv (MPa)
REBH15	7.0	0.65
REBH25	18.5	0.65
REBHT25	18.5	0.65
REBHT32	30.0	0.65

### Intermediate Stops

The cushion effect (smooth start-up, soft stop) exists only before the stroke end in the stroke ranges indicated in the table below.

The cushion effect (smooth start-up, soft stop) cannot be obtained in an intermediate stop or a return from an intermediate stop using an external stopper, etc.

Cushion stroke

Model	Stroke (mm)
REBH15	25
REBH25	30
REBHT25	30
REBHT32	30

Max. Speed  
300  
mm/s

Basic Type  
REAR

Direct Mount Type  
REAR

Slider Type/Slide Bearing  
REAS

Slider Type/Ball Bushing  
REAL

High Precision Guide Type  
REAH

Max. Speed  
600  
mm/s

Direct Mount Type  
REBR

High Precision Guide Type  
REBH

Auto Switches

Order Made

# Series REBH

## Stroke Adjustment

The adjustment bolt is adjusted to the optimum position for smooth acceleration and deceleration at the time of shipment, and should be operated at the full stroke. When stroke adjustment is necessary, the maximum amount of adjustment on one side is 2mm. (Do not adjust more than 2mm, as it will not be possible to obtain smooth acceleration and deceleration.)

Do not adjust based on the stopper's movement, as this can cause cylinder damage.

### Stroke Adjustment

Loosen the round head Phillips screws, and remove the top covers and dust covers (4pcs.). Then loosen the hexagon nut, and after performing the stroke adjustment from the plate side with a hexagon wrench, retighten and secure the hexagon nut.

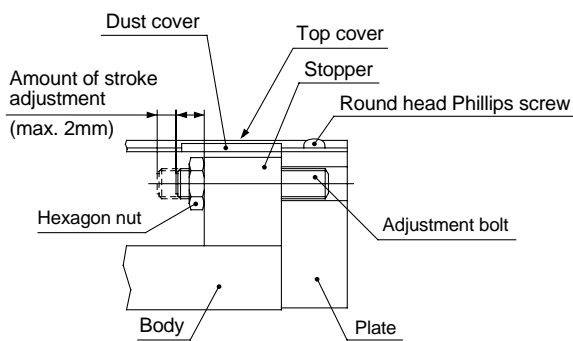

## Adjustment Bolt Position (at Shipment), Hexagon Nut Tightening Torque

Model	T (mm)	Tightening torque (N·m)
REBH15	7	1.67
REBH25	9	3.14
REBHT25	9	
REBHT32	9	

After adjusting the stroke, replace the top covers and dust covers. Tighten the round head Phillips screws for securing the top covers with a torque of 0.58N·m.



Construction/ø15, ø25

Single axis type/REBH

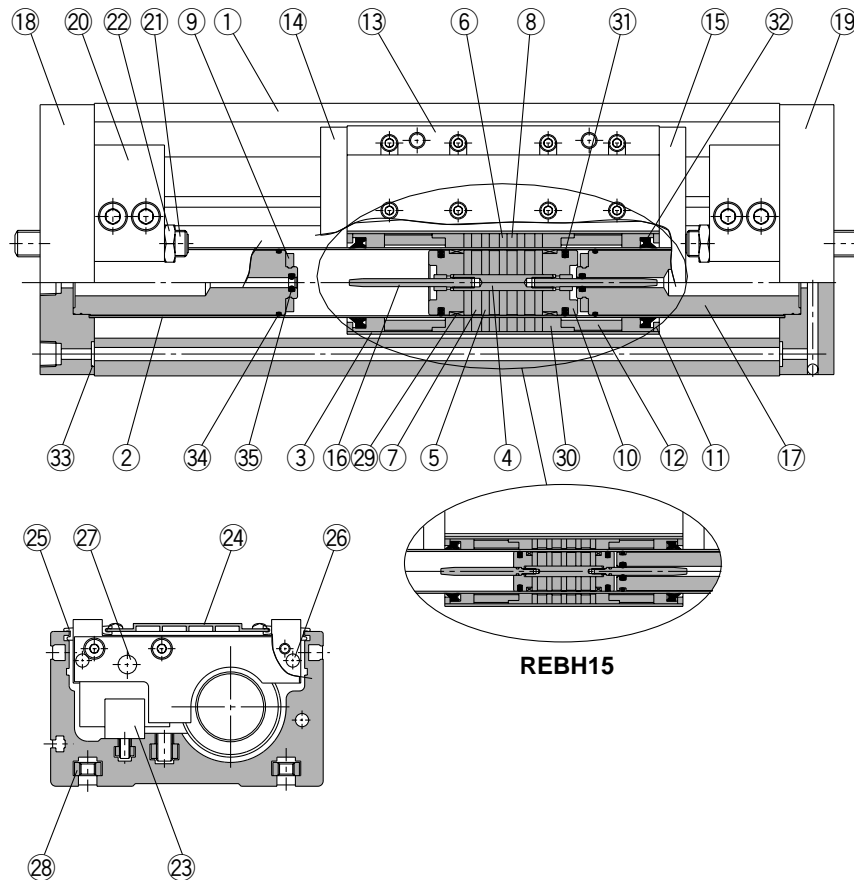

Parts list

No.	Description	Material	Note
1	Body	Aluminum alloy	Hard anodized
2	Cylinder tube	Stainless steel	
3	External slider tube	Aluminum alloy	
4	Shaft	Stainless steel	
5	Piston side yoke	Rolled steel plate	Zinc chromated
6	External slider side yoke	Rolled steel plate	Zinc chromated
7	Magnet A	Rare earth magnet	
8	Magnet B	Rare earth magnet	
9	Bumper	Urethane rubber	Except REBH15
10	Piston	Aluminum alloy	Chromated
11	Spacer	Rolled steel plate	Nickel plated
12	Space ring	Aluminum alloy	Chromated
13	Slide table	Aluminum alloy	Hard anodized
14	Side plate A	Aluminum alloy	Hard anodized
15	Side plate B	Aluminum alloy	Hard anodized
16	Cushion ring	Stainless steel	Compound electroless nickel plated
17	Internal stopper	Aluminum alloy	Anodized
18	Plate A	Aluminum alloy	Hard anodized

Parts list

No.	Description	Material	Note
19	Plate B	Aluminum alloy	Hard anodized
20	Stopper	Aluminum alloy	Anodized
21	Adjustment bolt	Chromium molybdenum steel	Nickel plated
22	Hexagon nut	Carbon steel	Nickel plated
23	Linear guide		
24	Top cover	Aluminum alloy	Hard anodized
25	Dust cover	Special resin	
26	Magnet (for auto switch)	Rare earth magnet	
27	Parallel pin	Carbon steel	Nickel plated
28	Square nut for body mounting	Carbon steel	Nickel plated (accessory)
29	Wear ring A	Special resin	
30	Wear ring B	Special resin	
31	Piston seal	NBR	
32	Scraper	NBR	
33	O-ring	NBR	
34	O-ring	NBR	
35	Cushion seal	NBR	

Replacement parts: Seal kits

Bore size (mm)	Kit no.	Contents
10	REBH15-PS	Above numbers
15	REBH25-PS	29, 30, 31, 32, 33, 34, 35

# Series REBH

Construction/ø25, ø32

Dual axis type/REBHT

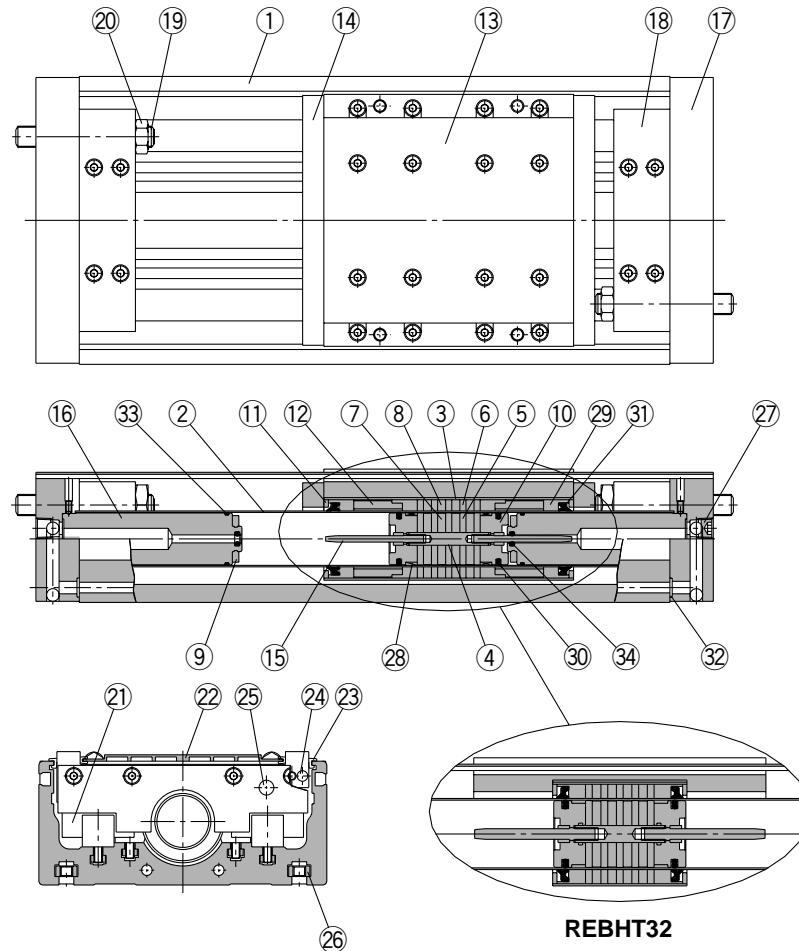

## Parts list

No.	Description	Material	Note
1	Body	Aluminum alloy	Hard anodized
2	Cylinder tube	Stainless steel	
3	External slider tube	Aluminum alloy	
4	Shaft	Stainless steel	
5	Piston side yoke	Rolled steel plate	Zinc chromated
6	External slider side yoke	Rolled steel plate	Zinc chromated
7	Magnet A	Rare earth magnet	
8	Magnet B	Rare earth magnet	
9	Bumper	Urethane rubber	
10	Piston	Aluminum alloy	Chromated
11	Spacer	Rolled steel plate	Nickel plated
12	Space ring	Aluminum alloy	Chromated (except REBHT32)
13	Slide table	Aluminum alloy	Hard anodized
14	Side plate	Aluminum alloy	Hard anodized (except REBHT32)
15	Cushion ring	Stainless steel	REBHT25 Compound electroless nickel plated
		Brass	REBHT32
16	Internal stopper	Aluminum alloy	Anodized
17	Plate	Aluminum alloy	Hard anodized

## Parts list

No.	Description	Material	Note
18	Stopper	Aluminum alloy	Anodized
19	Adjustment bolt	Chromium molybdenum steel	Nickel plated
20	Hexagon nut	Carbon steel	Nickel plated
21	Linear guide		
22	Top cover	Aluminum alloy	Hard anodized
23	Dust cover	Special resin	
24	Magnet (for auto switch)	Rare earth magnet	
25	Parallel pin	Carbon steel	Nickel plated
26	Square nut for body mounting	Carbon steel	Nickel plated (accessory)
27	Hexagon socket head taper plug	Carbon steel	Nickel plated
28	Wear ring A	Special resin	
29	Wear ring B	Special resin	
30	Piston seal	NBR	
31	Scraper	NBR	
32	O-ring	NBR	
33	O-ring	NBR	
34	Cushion seal	NBR	

## Replacement parts: Seal kits

Bore size (mm)	Kit no.	Contents
25	REBHT25-PS	Above numbers
32	REBHT32-PS	28, 29, 30, 31, 32, 33, 34

**Dimensions/ø15, ø25**

**Single axis type/REBH**

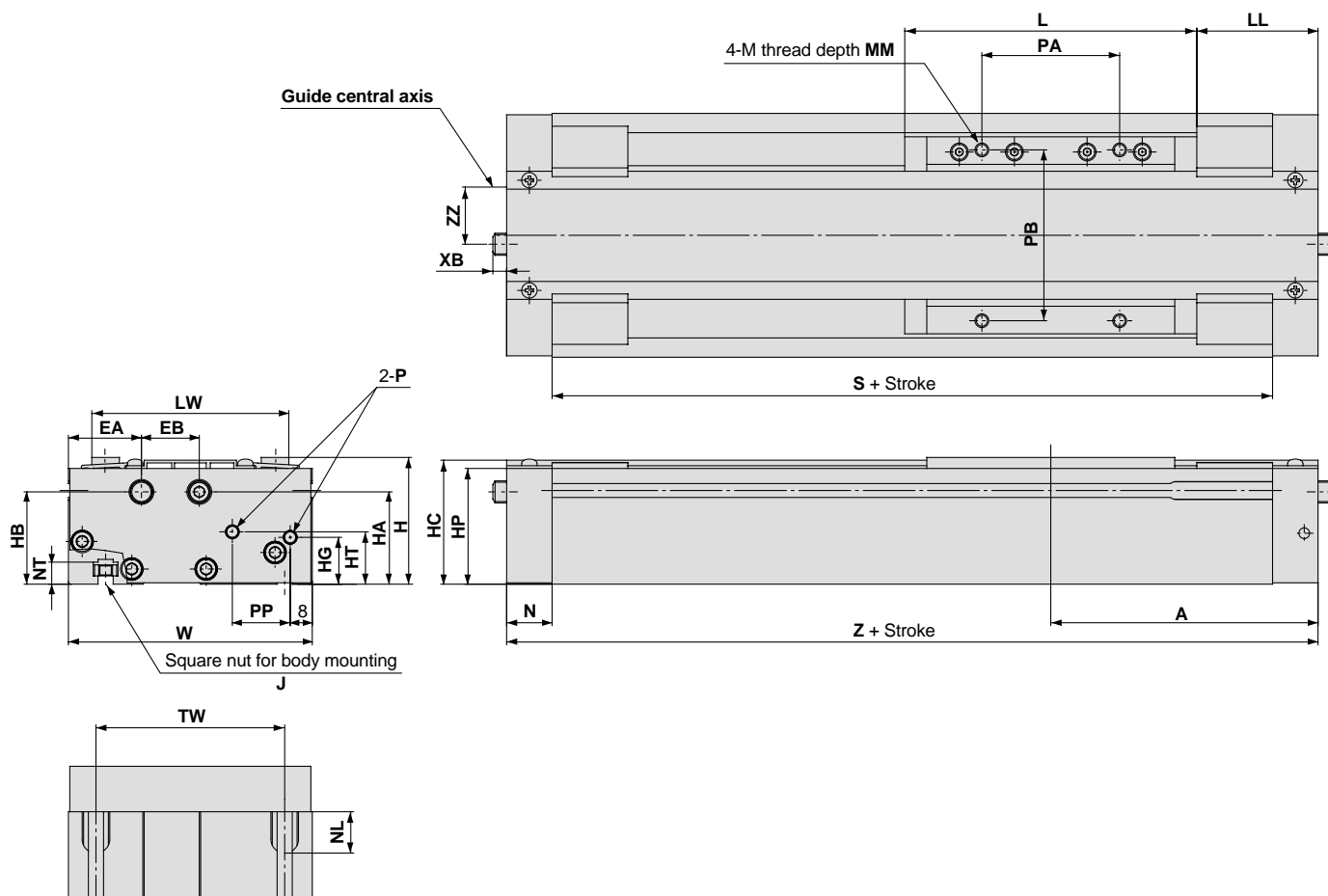

Model	A	EA	EB	H	HA	HB	HC	HG	HP	HT	J	L	LL	LW	M	MM
REBH15	97	26.5	21	46	33.5	33.5	45	17	42	19	M5 x 0.8	106	44	71.5	M5 x 0.8	8
REBH25	125	29	24	63	46	46	61.5	25	58.5	28	M6 x 1.0	138	56	86	M6 x 1.0	10

Model	N	NL	NT	P	PA	PB	PP	S	TW	W	XB	Z	ZZ
REBH15	16.5	15	8	M5 x 0.8	50	62	21	161	65	88.5	—	194	17.5
REBH25	20.5	18	9	Rc 1/8	65	75	27	209	75	103	9.5	250	23.5

Max. Speed  
300  
mm/s

Basic Type  
REA

Direct Mount Type  
REAR

Slider Type/Slide Bearing  
REAS

Slider Type/Ball Bushing  
REAL

High Precision Guide Type  
REAH

Max. Speed  
600  
mm/s

Direct Mount Type  
REBR

High Precision Guide Type  
REBH

Auto Switches

Order Made



**Proper Auto Switch Mounting Position for Stroke End Detection**

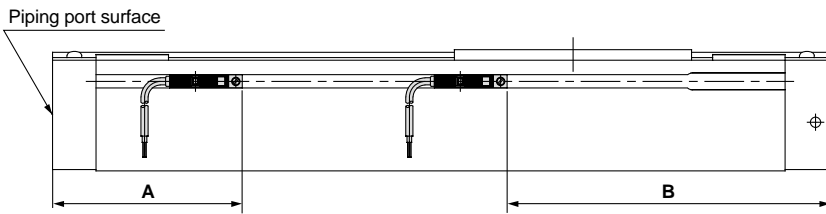

**Auto switch operating range**

(mm)

Auto switch model	Cylinder model	
	D-Z7□ D-Z80	D-Y7□W D-Y7□WV D-Y5□ D-Y6□ D-Y7P D-Y7PV
REBH15	6	5
REBH25	6	5
REBHT25	6	5
REBHT32	9	6

**Proper auto switch mounting position**

(mm)

Auto switch model	A			B		
	D-Z7□ D-Z80	D-Y7□W D-Y7□WV	D-Y5□ D-Y6□ D-Y7P D-Y7PV	D-Z7□ D-Z80	D-Y7□W D-Y7□WV	D-Y5□ D-Y6□ D-Y7P D-Y7PV
REBH15	72	72	72	122	122	122
REBH25	86	86	86	164	164	164
REBHT25	86	86	86	164	164	164
REBHT32	82	82	82	183	183	183

Note) Operating ranges are standards including hysteresis, and are not guaranteed. Large variations may occur depending on the surrounding environment. (variations on the order of ±30%)

**Auto Switch Mounting**

When mounting auto switches, they should be inserted into the cylinder's switch groove from the direction shown in the drawing on the right. After setting in the mounting position, use a flat head watchmakers screw driver to tighten the set screw which is included.

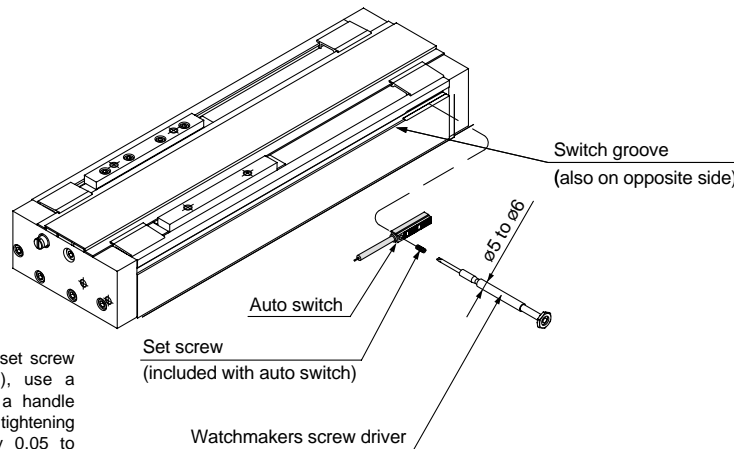

Note) When tightening the auto switch set screw (included with the auto switch), use a watchmakers screw driver with a handle about 5 to 6mm in diameter. The tightening torque should be approximately 0.05 to 0.1N·m.

**Auto Switch Lead Wire Containment Groove**

On model REBH25 a groove is provided on the side of the body (one side only) to contain auto switch lead wires. This should be used for placement of wiring.

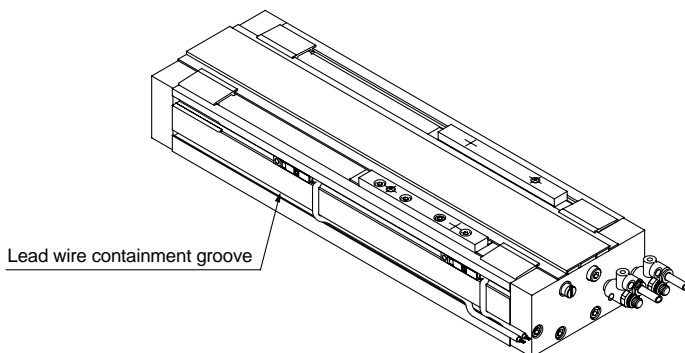

Max. Speed  
300 mm/s

Basic Type  
REAA

Direct Mount Type  
REAR

Slider Type/Slide Bearing  
REAS

Slider Type/Ball Bushing  
REAL

High Precision Guide Type  
REAH

Max. Speed  
600 mm/s

Direct Mount Type  
REBR

High Precision Guide Type  
REBH

Auto Switches

Order Made

# Series REA/REB

# Auto Switch Specifications

Auto switch application table

Auto switch model		Cylinder model					
		REAR	REBR	REAS	REAL	REAH	REBH
Reed switches	D-A72, D-A73, D-A80			●	●		
	D-A72H, D-A73H, D-A76H, D-A80H			●	●		
	D-A73C, D-A80C			●	●		
	D-A90, D-A93, D-A96	Note 1)	Note 1)				
Solid state switches	D-Z73, D-Z76, D-Z80	Note 2)	Note 2)			●	●
	D-F79, D-F7P, D-J79			●	●		
	D-F7NV, D-F7PV, D-F7BV			●	●		
	D-J79C			●	●		
	D-F79W, D-F7PW, D-J79W			●	●		
	D-F7NWV, D-F7BWV			●	●		
	D-F9N, D-F9P, D-F9B	Note 1)	Note 1)				
	D-Y59A, D-Y7P, D-Y59B	Note 2)	Note 2)			●	●
	D-Y69A, D-Y7PV, D-Y69B					●	●
	D-Y7NW, D-Y7PW, D-Y7BW	Note 2)	Note 2)			●	●
	D-Y7NWV, D-Y7PWV, D-Y7BWV					●	●
	D-F7BA			●	●		
	D-F7NT			●	●		
	D-F79F			●	●		
	D-F7LF			●	●		

Note 1) Indicates auto switches for REAR10/15/20 and REBR15.

Note 2) Indicates auto switches for REAR25/32/40 and REBR25/32.

Note 3) Refer to "Auto Switch Guide" (E274-A) for detailed specifications (specifications, dimensions, etc.) of switch units.

# Auto Switch Specifications

## ⚠ Specific Product Precautions

Before handling auto switches, be sure to read "Auto Switch Precautions" on pages 96 through 98.

### Auto Switch Common Specifications

Type	Reed switch	Solid state switch
Leakage current	None	3 wire: 10μA or less 2 wire: 1mA or less
Actuation time	1.2ms	1ms or less <sup>Note 2)</sup>
Impact resistance	300m/s <sup>2</sup>	1000m/s <sup>2</sup>
Insulation resistance	50MΩ or more at a 500VDC (between lead wire & case)	
Withstand voltage	1500VAC for 1 minute <sup>Note 1)</sup> (between lead wire & case)	1000VAC for 1 minute (between lead wire & case)
Ambient temperature	-10 to 60°C	

Note 1) Electrical entry: Connector type (A73C, A80C, C73C) and A9 are 1000VAC for 1 minute (between lead wire and case).

Note 2) Except for solid state auto switch with timer (F7NTL).

### Lead Wire Length

#### Lead wire length indication (Example)

D-A73

**L**

• Lead wire length

Nil	0.5m
L	3m
Z	5m
N*	None

\* Applicable only to connector type switch D-□□C.

Note 1) Lead wire length Z: 5m applicable auto switches  
Reed switch: D-A73(C)(H)/A80C, D-Z73  
Solid state switch: All models are produced upon receipt of order (standard procedure). Except for D-F9/F7□WV.

Note 2) The standard lead wire length is 3m for solid state switches with timer and water resistant solid state switches with 2 color indication. (0.5m length is not available.)

Note 3) The standard lead wire lengths are 3m and 5m for strong magnetic field resistant 2 color indicator type solid state switches. (0.5m length is not available.)

#### Part nos. for lead wires with connector (applicable only to connector type switches)

Model	Lead wire length
D-LC05	0.5m
D-LC30	3m
D-LC50	5m

### Auto Switch Hysteresis

The distance from the position at which movement of the external slider turns on an auto switch, to the point at which reverse movement turns off the switch is called hysteresis. This hysteresis is included in part (one side) of the operating range.

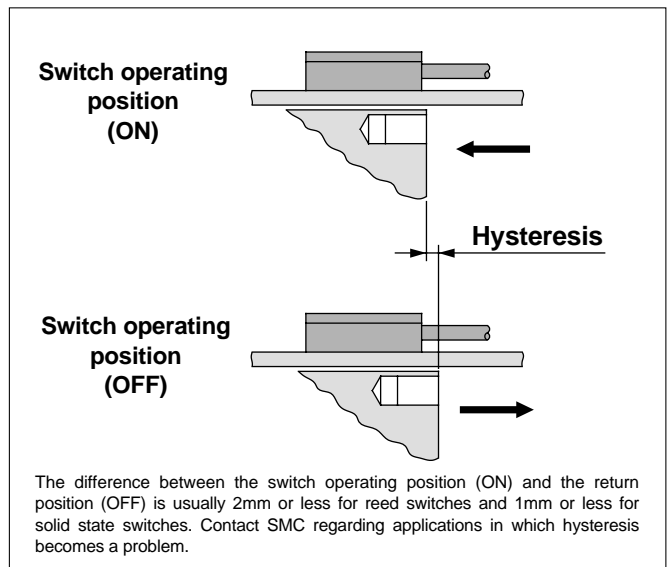

The difference between the switch operating position (ON) and the return position (OFF) is usually 2mm or less for reed switches and 1mm or less for solid state switches. Contact SMC regarding applications in which hysteresis becomes a problem.

### Recommended Relays

Fuji Electric Co., Ltd. ....	HH5
OMRON Corporation ....	MY
Matsushita Electric Works, Ltd. ....	HC
Tokyo Electric ....	MPM
IDEK IZUMI CORPORATION ....	RM
Mitsubishi Electric Corporation ....	RD

Max. Speed  
300  
mm/s

Basic Type  
REA

Direct Mount Type  
REAR

Slider Type/Side Bearing  
REAS

Slider Type/Ball Bushing  
REAL

High Precision Guide Type  
REAH

Max. Speed  
600  
mm/s

Direct Mount Type  
REBR

High Precision Guide Type  
REBH

Auto Switches

Order Made

# Series REA/REB Auto Switch Specifications

## Contact Protection Box/CD-P11, CD-P12

1.

### <Applicable switches>

D-A7/A8, D-A7□H/A80H, D-A73C, A80C, D-Z7/Z8, D-A9

The above auto switches do not have built-in contact protection circuits.

1. The operating load is an induction load.

2. The length of wiring to the load is 5m or more.

3. The load voltage is 100V or 200VAC.

A contact protection box should be used in any of the above cases, as the life of the contacts may be reduced. (They may stay on continuously.)

Since this effect is especially strong in the case of type D-A72(H), a contact protection box should always be used, regardless of the type of load or length of wiring.

### Contact protection box specifications

Part no.	CD-P11		CD-P12
Load voltage	100VAC	200VAC	24VDC
Max. load current	25mA	12.5mA	50mA

\*Lead wire length — Switch connection side 0.5m  
Load connection side 0.5m



### Contact protection box internal circuits

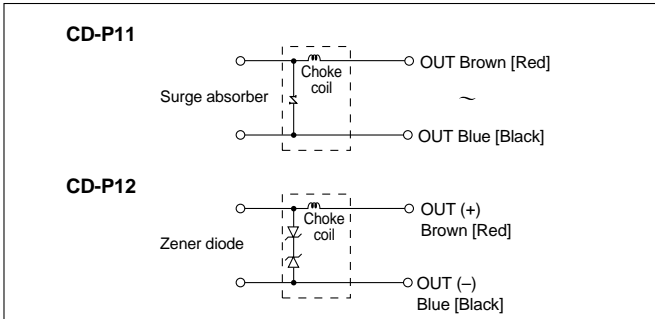

### Contact protection box dimensions

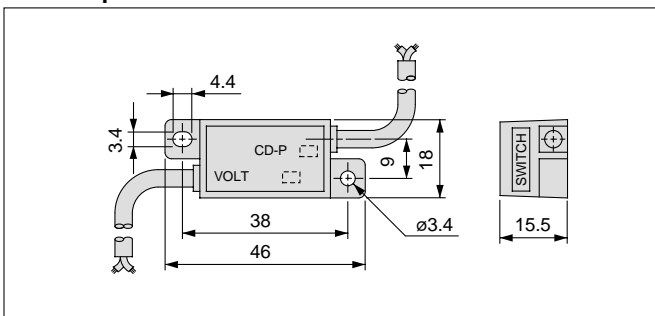

### Contact protection box connection

To connect a switch unit to a contact protection box, connect the lead wire from the side of the contact protection box marked SWITCH to the lead wire coming out of the switch unit.

Moreover, the switch unit should be kept as close as possible to the contact protection box, with a lead wire length of no more than 1m.

## Auto Switch Internal Circuits

### Reed switches

#### D-A72, D-A72H

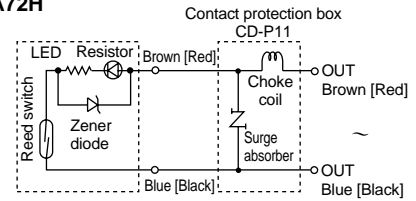

#### D-A73, D-A73H, D-A93

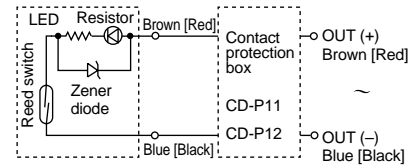

#### D-A76H, D-A96

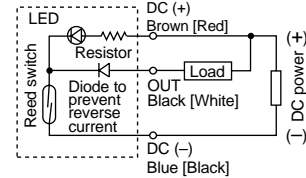

#### D-A80, D-A80H, D-A90

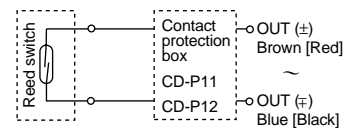

#### D-A73C

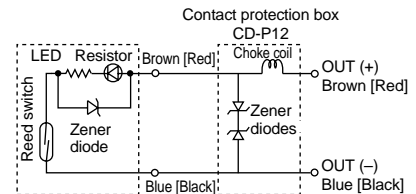

#### D-A80C

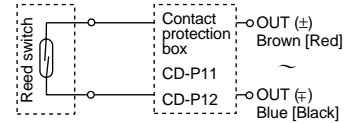

#### D-Z73

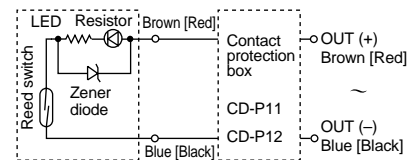

#### D-Z76

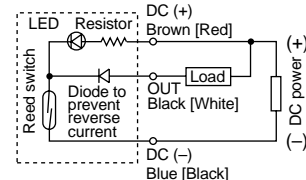

#### D-Z80

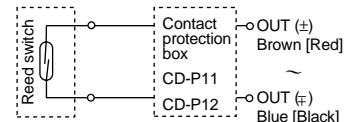

Note) Lead wire colors inside [ ] are those prior to conformity with IEC standards.



# Series REA/REB

# Auto Switch Specifications

## Auto Switch Internal Circuits

Note) Lead wire colors inside [ ] are those prior to conformity with IEC standards.

### Solid state switches

**D-F79, D-F7NV**

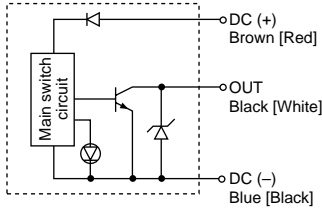

**D-F7P, D-F7PV**

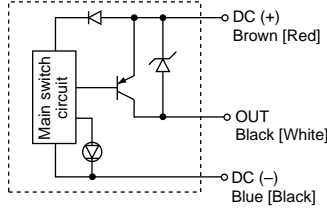

**D-J79, D-J79C, D-F7BV**

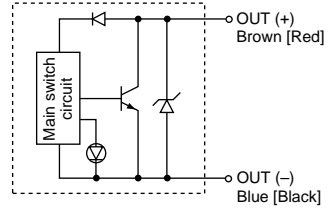

**D-F79W**

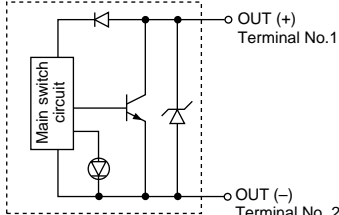

**D-F7PW**

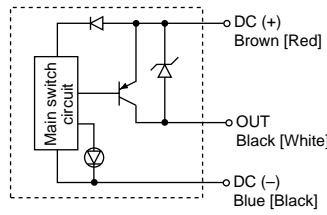

**D-J79W**

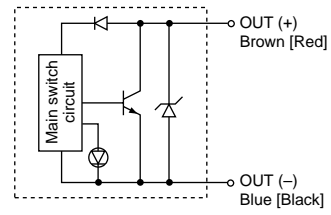

**D-F7NT**

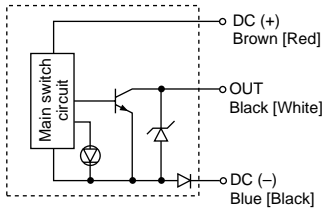

**D-F7LF**

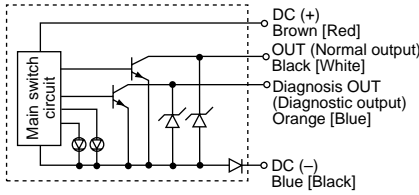

**D-F79F**

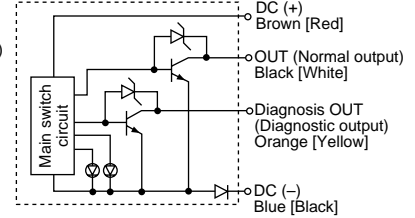

**D-F9N**

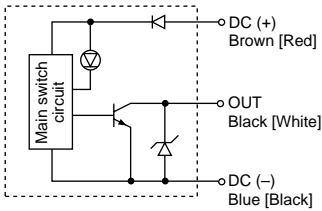

**D-F9P**

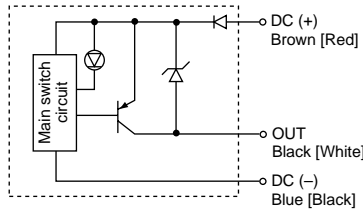

**D-F9B**

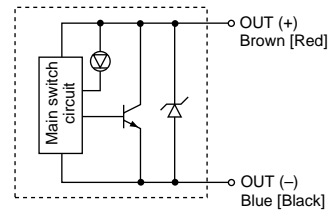

**D-Y59A, D-Y69A**

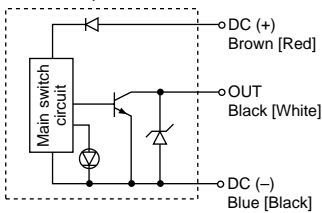

**D-Y7P(V)**

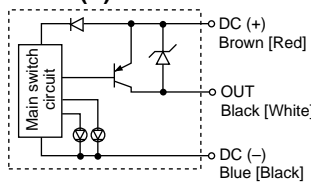

**D-Y59B, D-Y69B**

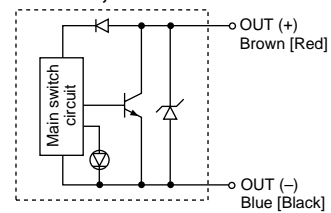

**D-Y7NW(V)**

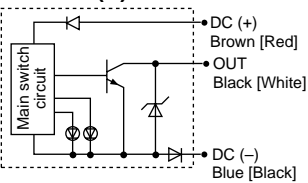

**D-Y7PW(V)**

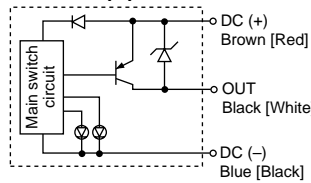

**D-Y7BW(V)**

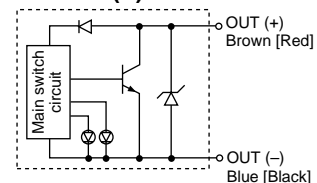

**D-F7BA**

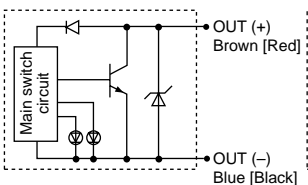

**D-F7NWV**

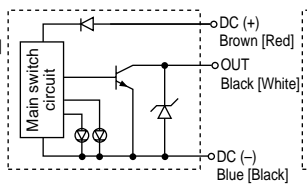

**D-F7BWV**

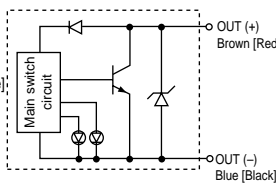

**Indicator lights/Method of indication**

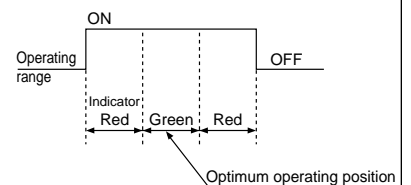

Max. Speed  
300  
mm/s

Basic Type  
REA

Direct Mount Type  
REAR

Slider Type/Slide Bearing  
REAS

Slider Type/Ball Bushing  
REAL

High Precision Guide Type  
REAH

Max. Speed  
600  
mm/s

Direct Mount Type  
REBR

High Precision Guide Type  
REBH

Auto Switches

Order Made

# Series REA/REB Auto Switch Connections and Examples

## Basic Wiring

Note) Lead wire colors inside [ ] are those prior to conformity with IEC standards.

### Solid state 3 wire, NPN

(Power supply for switch and load are the same.)

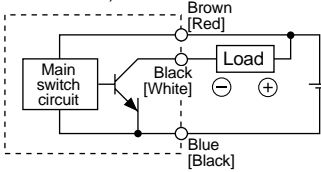

### Solid state 3 wire, PNP

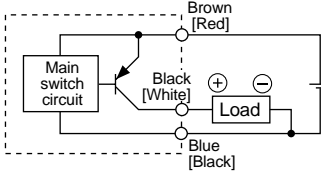

### 2 wire <Solid state>

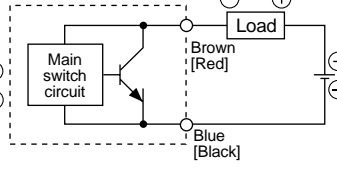

### 2 wire <Reed switch>

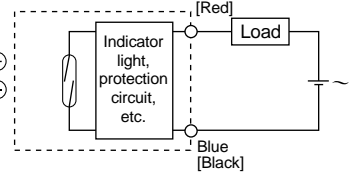

(Power supply for switch and load are separate.)

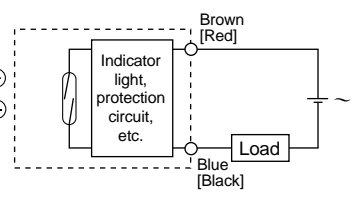
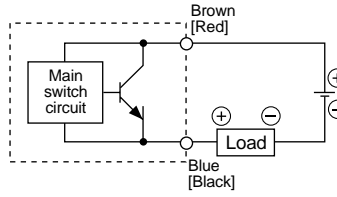
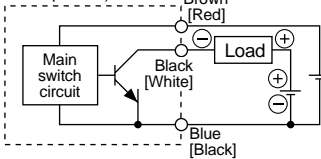

## Examples of Connection to PLC (Programmable Logic Controller)

### Specification for sink input

#### 3 wire, NPN

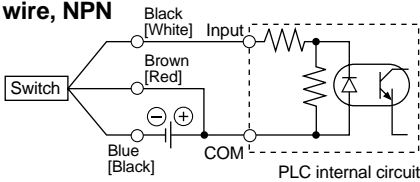

### Specification for source input

#### 3 wire, PNP

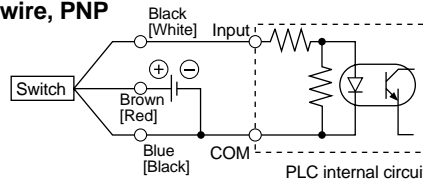

Connect according to the applicable PLC input specifications, as the connection method will vary depending on the PLC input specifications.

#### 2 wire

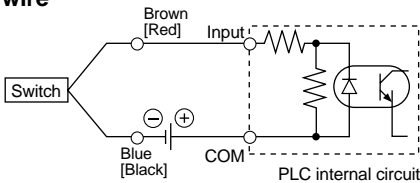

#### 2 wire

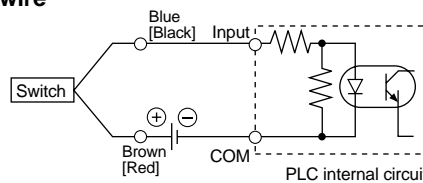

## Connection Examples for AND (Series) and OR (Parallel)

### 3 wire

#### AND connection for NPN output (Using relays)

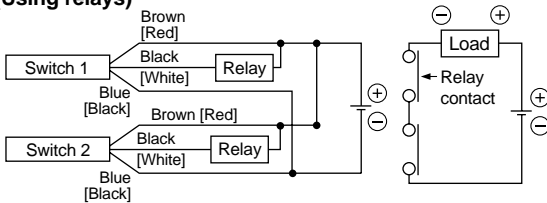

#### AND connection for NPN output (Performed with switches only)

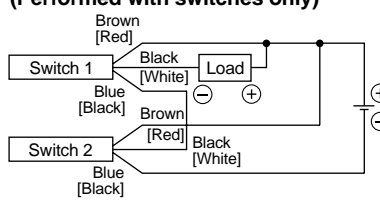

#### OR connection for NPN output

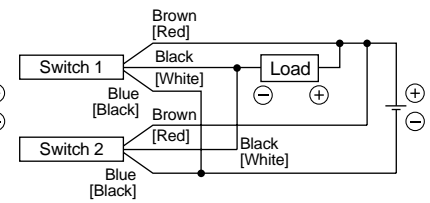

The indicator lights will light up when both switches are turned ON.

### 2 wire with 2 switch AND connection

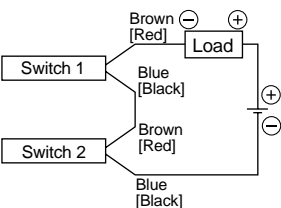

When two switches are connected in series, the load may malfunction because the load voltage will decline when in the ON state. The indicator lights will light up if both of the switches are in the ON state.

### 2 wire with 2 switch OR connection

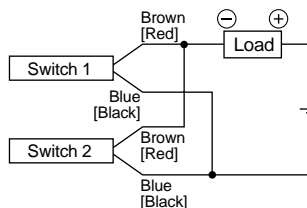

#### <Solid state>

When two switches are connected in parallel, malfunction may occur because the load voltage will increase when in the OFF state.

#### <Reed switch>

Because there is no current leakage, the load voltage will not increase when turned OFF. However, due to the number of switches in the ON state, the indicator lights will sometimes dim or not light up, because of dispersion and reduction of the current flowing to the switches.

$$\begin{aligned} \text{Load voltage at ON} &= \text{Power supply voltage} - \text{Residual voltage} \times 2 \text{ pcs.} \\ &= 24\text{V} - 4\text{V} \times 2 \text{ pcs.} \\ &= 16\text{V} \end{aligned}$$

Example: Power supply is 24VDC.  
Voltage drop in switch is 4V.

$$\begin{aligned} \text{Load voltage at OFF} &= \text{Leakage current} \times 2 \text{ pcs.} \times \text{Load impedance} \\ &= 1\text{mA} \times 2 \text{ pcs.} \times 3\text{k}\Omega \\ &= 6\text{V} \end{aligned}$$

Example: Load impedance is 3kΩ.  
Leakage current from switch is 1mA.

# Series REA/REB

## Individual Order Made Specifications



Contact SMC for detailed specifications, lead times and prices, etc.

Max. Speed  
300  
mm/s

Order made product application table

Specifications		Model	Bore size (mm)							
			10	15	20	25	32	40	50	63
1	XB11 (Long stroke) P. 88	REA				●	●	●	●	●
		REA				●	●	●	●	●
2	XC24 (With magnetic shielding plate) P. 88	REA				●	●	●	●	●
		REA				●	●	●	●	●
		REAR	●	●	●	●	●	●	●	●
3	XC57 (With floating joint) P. 88 P. 89	REBR		●		●	●	●	●	●
		REA				●	●	●	●	●
		REAR			○	○	○	○		
		REAS			●	●	●	●	●	●
4	X168 (Helical insert thread specification) P. 90	REAL			●	●	●	●	●	●
		REAH			●	●	●	●	●	●
		REBH				●	●	●	●	●
		REA				●	●	●	●	●
		REAS	●	●	●	●	●	●	●	●
5	X206 (Body mounting surface, 2 sides) P. 90	REA				●	●	●	●	●
		REAS	●	●	●	●	●	●	●	●
6	X210 (Non-lubricated exterior specification) P. 90	REA				●	●	●	●	●
		REAS	●	●	●	●	●	●	●	●
7	X324 (Non-lubricated exterior specification with dust seal) P. 91	REA				●	●	●	●	●
		REAS	●	●	●	●	●	●	●	●
8	X431 (With 2 switch rails) P. 91	REAS	●	●	●	●	●	●	●	●
		REAL	○	○	○	○	○	○		
9	XB10 (Intermediate stroke) P. 91	REAH	●	●	●	●	●	●	●	●
		REBH		●		●	●	●	●	●

Basic Type  
REA

Direct Mount Type  
REAR

Slider Type/Slide Bearing  
REAS

Slider Type/Ball Bushing  
REAL

High Precision Guide Type  
REAH

Max. Speed  
600  
mm/s

Direct Mount Type  
REBR

High Precision Guide Type  
REBH

Auto Switches

Order Made

Note) The applicable series and bore sizes of products are indicated by the "●" symbol. Contact SMC regarding products with the "○" symbol.

# Series REA

# Order Made Specifications 1

Contact SMC for detailed specifications, lead times and prices, etc.



## 1 Long stroke (2001mm and up) Symbol -XB11

REA Bore size - Stroke - **XB11**

Long stroke (2001mm and up)

When the stroke exceeds 2000mm (2001mm and up)

### Specifications

Applicable series	REA
Bore size	ø25 to ø63
Applicable stroke	2001mm and up

## 2 With magnetic shielding plate Symbol -XC24

REA Bore size - Stroke - **XC24**

With magnetic shielding plate

Shields against leakage of magnetic flux from the external slider.

### Specifications

Applicable series	REA
Bore size	ø25 to ø63

### Dimensions

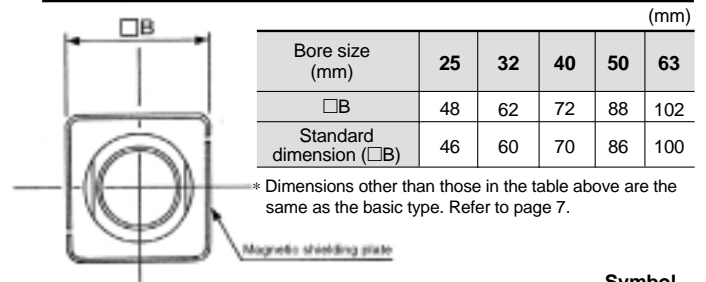

## 3 With floating joint (REA) Symbol -XC57

REA Bore size - Stroke - **XC57**

With floating joint

A special floating joint is added to the Series REA, and the labor for connections to the guide on the other axis (the load side) is reduced.

The attachment of the bolt to the floating joint and the load is not limited to the top or bottom.

### Specifications

Fluid	Air
Cylinder bore size	ø25, ø32, ø40, ø50, ø63
Max. operating pressure	0.7MPa
Min. operating pressure	0.18MPa
Piston speed	50 to 300mm/s
Mounting orientation	Free
Auto switch	Not mountable

Note) Since the body of this cylinder is designed for connection with a floating joint, and cannot be connected to the bodies of standard products, contact SMC if necessary.

### Construction/Dimensions

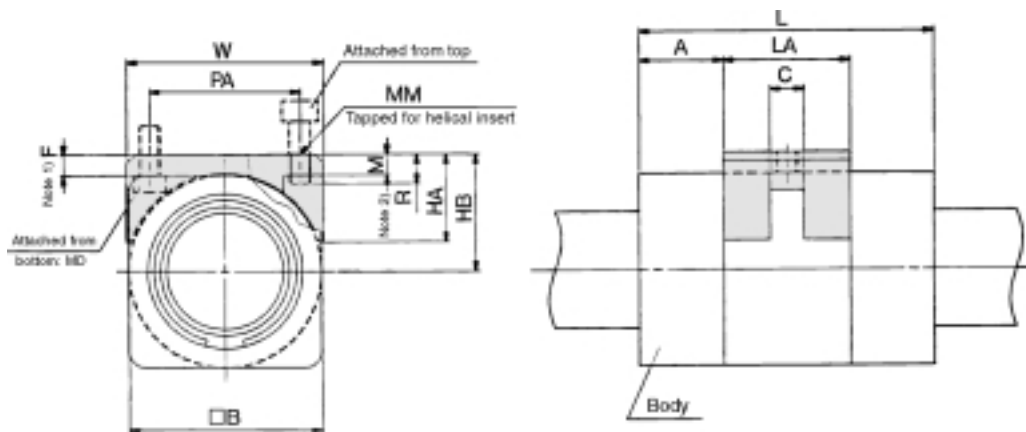

Model	A	□B	C	F Note 1)	HA	HB	L	LA	MM	MD	M	PA	R Note 2)	W
REA25	20	46	8.0	5.5	21	28.5	70	30	M5 x 0.8	M4	5	36	7	47
REA32	22.5	60	9.5	6.0	27.5	36	80	35	M6 x 1.0	M5	6	47	8	61
REA40	26	70	9.5	6.0	28.5	41	92	40	M6 x 1.0	M5	6	55	8	71
REA50	35	86	11	6.0	35	49	110	40	M8 x 1.25	M6	8	65	11	87
REA63	36	100	18	7.0	42	57	122	50	M8 x 1.25	M6	10	80	11	101

Note 1) Dimension F provides a clearance of 1mm between the body and the floating joint, but does not consider self weight deflection of the cylinder tube, etc. When put into operation, an appropriate value should be set which considers self weight deflection and alignment variations with respect to the other axis. (Refer to the self weight deflection table on page 5.)

Note 2) Use caution when attached from the top and operated at or above dimension R, because the end of the screw will contact the body, and a floating condition will not be maintained in some cases.

# Series REA/REB

## Order Made Specifications 2

Contact SMC for detailed specifications, lead times and prices, etc.



Max. Speed  
300  
mm/s

Basic Type  
REA

Direct Mount Type  
REAR

Slider Type/Slide Bearing  
REAS

Slider Type/Ball Bushing  
REAL

High Precision Guide Type  
REAH

Max. Speed  
600  
mm/s

Direct Mount Type  
REBR

High Precision Guide Type  
REBH

Auto Switches

Order Made

### 3 With floating joint (REAR/REBR) Cont'd

Symbol  
**-XC57**

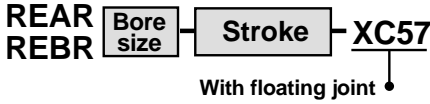

A special floating joint is added to the Series REAR, and the labor for connections to the guide on the other axis (the load side) is reduced. The attachment of the bolt to the floating joint and the load is not limited to the top or bottom.

### Specifications

	REAR	REBR
Fluid	Air	
Cylinder bore size	ø10, ø15, ø20, ø25, ø32, ø40	ø15, ø25, ø32
Max. operating pressure	0.7MPa	
Min. operating pressure	0.18MPa	
Piston speed	50 to 300mm/s	50 to 600mm/s
Mounting	Direct mount type	
Auto switch	Mountable	

Note) Since the body of this cylinder is designed for connection with a floating joint, and cannot be connected to the bodies of standard products, contact SMC if necessary.

### Construction/Dimensions

#### ø10, ø15

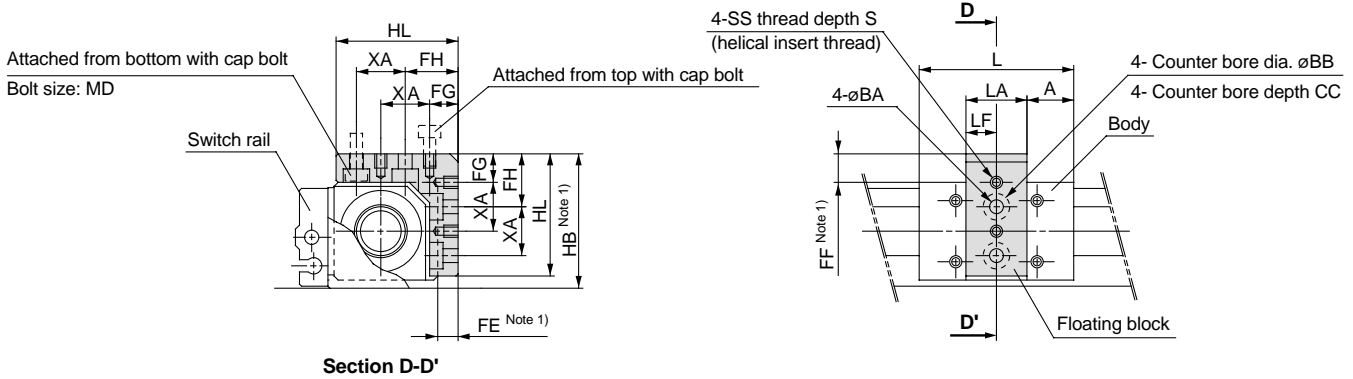

#### ø20, ø25, ø32, ø40

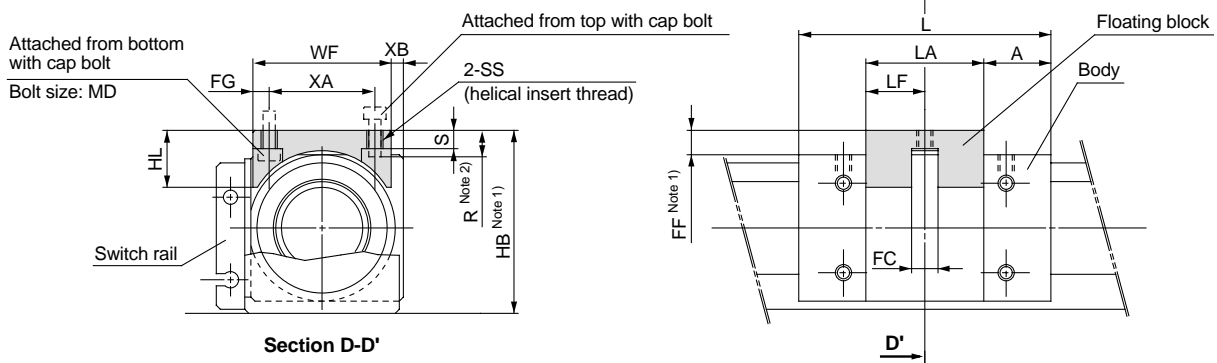

Bore size	A	BA	BB	CC	FC	FE Note 1)	FF Note 1)	FG	FH	HB Note 1)	HL	L	LA	LF	MD	R Note 2)	S	SS	WF	XA	XB
ø10	11.5	3.4	6.5	3.3	—	5	7	7	13	33	30	38	15	7.5	M3	—	3.5	M3 x 0.5	—	12	—
ø15	18	4.5	8	4.4	—	4.5	6.5	7.5	14.5	38.5	35.5	53	17	8.5	M4	—	4.5	M4 x 0.7	—	14	—
ø20	16.5	—	—	—	6.5	—	6	4	—	45	14	62	29	14.5	M3	7	4.5	M4 x 0.7	34	26	3
ø25	20.5	—	—	—	8	—	7	4	—	51	17	70	29	14.5	M4	8	5.5	M5 x 0.8	39	31	3
ø32	21	—	—	—	9.5	—	7.5	4.5	—	62.5	22	76	34	17	M5	10	6.5	M6 x 1	50	41	3
ø40	25.5	—	—	—	9.5	—	7.5	7.5	—	74.5	28	90	39	19.5	M5	10	6.5	M6 x 1	60	45	3

Note 1) FE, FF and HB provide a clearance of 1mm between the body and the floating joint, but do not consider self weight deflection of the cylinder tube, etc. When put into operation, an appropriate value should be set which considers self weight deflection and alignment variations with respect to the other axis. (Refer to the self weight deflection table on pages 13 and 63.)

Note 2) Use caution when attached from the top and operated at or above dimension R, because the end of the screw will contact the body, and a floating condition will not be maintained in some cases.

# Series REA/REB Order Made Specifications 3



Contact SMC for detailed specifications, lead times and prices, etc.

## 4 Helical insert thread specification Symbol -X168

REA  
REAS  
REAL  
REAH  
REBH

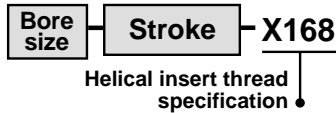

The standard mounting threads have been changed to helical insert specifications.

### Specifications

Applicable series	REA, REAS, REAL, REAH, REBH
Bore size	REA: $\phi 25$ to $\phi 63$ REAS, REAL: $\phi 20$ to $\phi 40$ REAH: $\phi 20$ to $\phi 32$ REBH: $\phi 25$ to $\phi 32$

The mounting thread positions and size are the same as standard.

## 5 Additional mounting tap positions for slider Symbol -X206

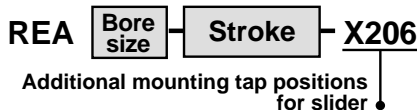

Mounting taps have been added on the surface opposite the standard positions.

### Specifications

Applicable series	REA
Bore size	$\phi 25$ to $\phi 63$

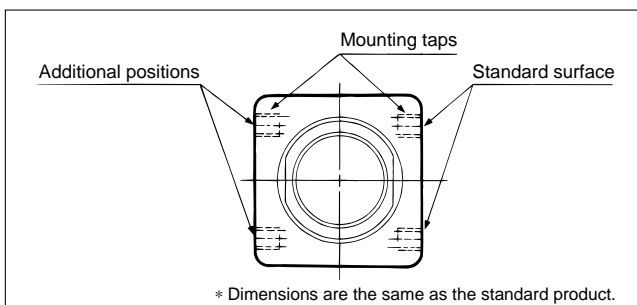

## 6 Non-lubricated exterior specification Symbol -X210

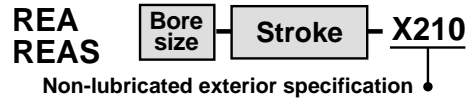

Suitable for environments where oils are not tolerated. A scraper is not installed. A separate version -X324 (with dust seal) is available for cases in which dust, etc., is scattered throughout the environment.

### Specifications

Applicable series		REA, REAS
Bore size	REA	$\phi 25$ to $\phi 63$
	REAS	$\phi 10$ to $\phi 40$

### Construction

#### REA (basic type)

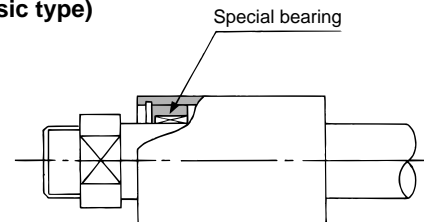

#### REAS (slider type)

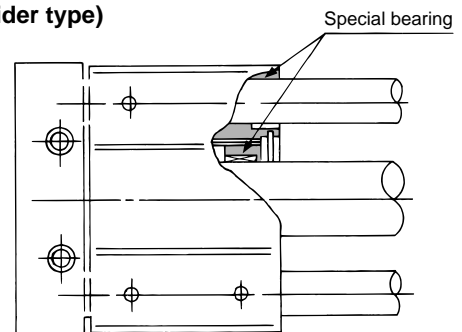

# Series REA/REB

## Order Made Specifications 4

Contact SMC for detailed specifications, lead times and prices, etc.



Max. Speed  
300  
mm/s

Basic Type  
REA

Direct Mount Type  
REAR

Slider Type/Slide Bearing  
REAS

Slider Type/Ball Bushing  
REAL

High Precision Guide Type  
REAH

Max. Speed  
600  
mm/s

Direct Mount Type  
REBR

High Precision Guide Type  
REBH

Auto Switches

Order Made

### 7 Non-lubricated exterior specification (with dust seal) -X324

Symbol

REA Bore size Stroke -X324  
REAS

Non-lubricated exterior specification (with dust seal)

This unit has non-lubricated exterior specifications, with a felt dust seal provided on the cylinder body.

#### Specifications

Applicable series		REA, REAS
Bore size	REA	ø25 to ø63
	REAS	ø10 to ø40

#### Construction

##### REA (basic type)

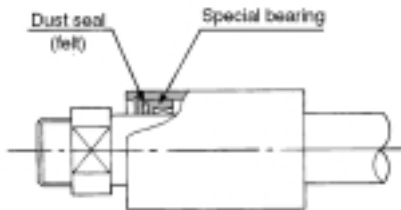

##### REAS (slider type)

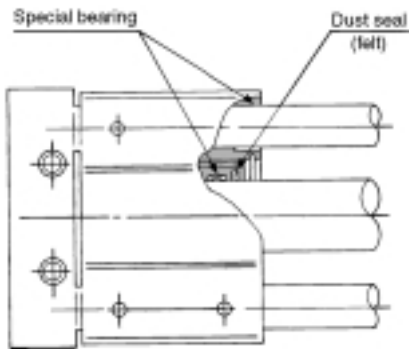

### 8 Switch rail mounting on both sides (with 2pcs.) -X431

Symbol

REAS Bore size Stroke -X431

Switch rail mounting on both sides (with 2pcs.)

Effective in cases with switches when the stroke is short.

#### Specifications

Applicable series	REAS
Bore size	ø10 to ø40

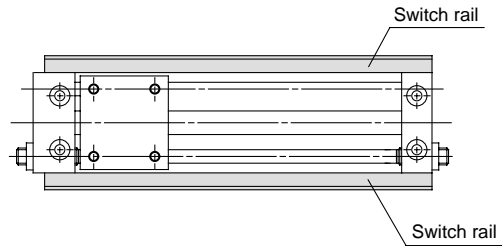

### 9 Intermediate stroke -XB10

Symbol

REAH Bore size Stroke -XB10  
REBH

(Refer to table below.) Intermediate stroke

#### Strokes

Bore size	150	175	200	225	250	275	300	325	350	375	400	425	450	475	500	525	550	575	600	650	700	750	800	850	900	950	1000
REAH10	●	○	●	○	○	○	●	/	/	/	/	/	/	/	/	/	/	/	/	/	/	/	/	/	/	/	/
RE <sub>B</sub> AH15	●	○	●	○	○	○	●	○	○	○	○	●	○	○	○	○	○	○	○	○	○	○	○	○	○	○	○
REAH20	/	/	●	○	○	○	○	○	○	○	○	○	○	○	○	○	○	○	○	○	○	○	○	○	○	○	○
RE <sub>B</sub> AH25	/	/	●	—	○	—	●	—	○	—	●	—	○	—	●	—	○	—	●	○	○	○	○	○	○	○	○
RE <sub>B</sub> AHT25	/	/	●	—	○	—	●	—	○	—	●	—	○	—	●	—	○	—	●	○	○	○	○	○	○	○	○
RE <sub>B</sub> AHT32	/	/	●	—	○	—	●	—	○	—	●	—	○	—	●	—	○	—	●	○	○	○	○	○	○	○	○

● : Standard strokes  
○ : Strokes available with -XB10  
— : Not available



Series **REA/REB**

# Safety Instructions

These safety instructions are intended to prevent a hazardous situation and/or equipment damage. These instructions indicate the level of potential hazard by a label of "**Caution**", "**Warning**" or "**Danger**". To ensure safety, be sure to observe ISO 4414 Note 1), JIS B 8370 Note 2) and other safety practices.

**⚠ Caution :** Operator error could result in injury or equipment damage.

**⚠ Warning :** Operator error could result in serious injury or loss of life.

**⚠ Danger :** In extreme conditions, there is a possible result of serious injury or loss of life.

Note 1) ISO 4414: Pneumatic fluid power – Recommendations for the application of equipment to transmission and control systems

Note 2) JIS B 8370: General Rules for Pneumatic Equipment

## **⚠ Warning**

### **1. The compatibility of pneumatic equipment is the responsibility of the person who designs the pneumatic system or decides its specifications.**

Since the products specified here are used in various operating conditions, their compatibility for the specific pneumatic system must be based on specifications or after analysis and/or tests to meet your specific requirements.

### **2. Only trained personnel should operate pneumatically operated machinery and equipment.**

Compressed air can be dangerous if an operator is unfamiliar with it. Assembly, handling or repair of pneumatic systems should be performed by trained and experienced operators.

### **3. Do not service machinery/equipment or attempt to remove components until safety is confirmed.**

1. Inspection and maintenance of machinery/equipment should only be performed after confirmation of safe locked-out control positions.

2. When equipment is to be removed, confirm the safety process as mentioned above. Cut the supply pressure for this equipment and exhaust all residual compressed air in the system.

3. Before machinery/equipment is restarted, take measures to prevent shooting-out of cylinder piston rod, etc. (Bleed air into the system gradually to create back-pressure.)

### **4. Contact SMC if the product is to be used in any of the following conditions:**

1. Conditions and environments beyond the given specifications, or if product is used outdoors.

2. Installation on equipment in conjunction with atomic energy, railway, air navigation, vehicles, medical equipment, food and beverages, recreation equipment, emergency stop circuits, press applications, or safety equipment.

3. An application which has the possibility of having negative effects on people, property, or animals, requiring special safety analysis.





# Series REA/REB Actuator Precautions 1

Be sure to read before handling.

## Design

### ⚠ Warning

**1. There is a possibility of dangerous sudden action by air cylinders if sliding parts of machinery are twisted and changes of force occur.**

In such cases, human injury may occur; e.g., by catching hands or feet in the machinery, or damage to the machinery itself may occur. Therefore, the machine should be designed to avoid such dangers.

**2. A protective cover is recommended to minimize the risk of personal injury.**

If a driven object and moving parts of a cylinder pose a danger of personal injury, design the structure to avoid contact with the human body.

**3. Securely tighten all stationary parts and connected parts so that they will not become loose.**

Particularly when a cylinder operates with high frequency or a cylinder is installed where there is a lot of vibration, ensure that all parts remain secure.

**4. Consider a possible drop in circuit pressure due to a power outage, etc.**

When a cylinder is used in a clamping mechanism, there is a danger of work pieces dropping if there is a decrease in clamping force due to a drop in circuit pressure caused by a power outage, etc. Therefore, safety equipment should be installed to prevent damage to machinery and human injury. Suspension mechanisms and lifting devices also require consideration for drop prevention.

**5. Consider a possible loss of power source.**

Measures should be taken to protect against human injury and equipment damage in the event that there is a loss of power to equipment controlled by pneumatics, electricity or hydraulics, etc.

**6. Design circuitry to prevent sudden lurching of driven objects.**

When a cylinder is driven by an exhaust center type directional control valve or when starting up after residual pressure is exhausted from the circuit, etc., the piston and its driven object will lurch at high speed if pressure is applied to one side of the cylinder because of the absence of air pressure inside the cylinder. Therefore, equipment should be selected and circuits designed to prevent sudden lurching, because there is a danger of human injury and/or damage to equipment when this occurs.

**7. Consider emergency stops.**

Design so that human injury and/or damage to machinery and equipment will not be caused when machinery is stopped by a safety device under abnormal conditions such as a power outage or a manual emergency stop.

**8. Consider the action when operation is restarted after an emergency stop or abnormal stop.**

Design the machinery so that human injury or equipment damage will not occur upon restart of operation. When the cylinder has to be reset at the starting position, install safe manual control equipment.

## Selection

### ⚠ Warning

**1. Check the specifications.**

The products advertised in this catalog are designed only for use in industrial compressed air systems. If the products are used in conditions where pressure, temperature, etc., are out of specification, damage and/or malfunction may be caused. Do not use in these conditions.

Consult SMC if you use a fluid other than compressed air.

**2. Intermediate stops**

When intermediate stopping of a cylinder piston is performed with a 3 position closed center type directional control valve, it is difficult to achieve stopping positions as accurate and minute as with hydraulic pressure, due to the compressibility of air.

Furthermore, since valves and cylinders, etc., are not guaranteed for zero air leakage, it may not be possible to hold a stopped position for an extended period of time. Contact SMC in case it is necessary to hold a stopped position for an extended period.

### ⚠ Caution

**1. Operate within the limits of the maximum usable stroke.**

Refer to the standard stroke table for the maximum usable stroke.

**2. Operate the piston within a range such that collision damage will not occur at the end of the stroke.**

Operate within a range such that damage will not occur when the piston having inertial force stops by striking the cover at the stroke end. Refer to the model selection pages for the range within which damage will not occur.

**3. Use a speed controller to adjust the cylinder drive speed, gradually increasing from a low speed to the desired speed setting.**



# Series REA/REB Actuator Precautions 2

Be sure to read before handling.

## Mounting

### ⚠ Caution

#### 1. Align carefully when connecting to a load having an external guide mechanism.

Since variation of the shaft center becomes greater as the stroke becomes longer, a connection method (floating mechanism) should be considered which allows for this variation.

Moreover, consideration should be given to the exclusive floating joint (XC57), which has been created for series REA, REAR and REBR.

#### 2. When an external guide is used, connect the external slider and the load in such a way that there is no interference at any point within the stroke.

#### 3. Do not scratch or gouge the sliding parts of the cylinder tube by striking or grasping them with other objects.

Cylinder bores are manufactured to precise tolerances, so that even a slight deformation may cause faulty operation.

#### 4. Do not use until you verify that the equipment can operate properly.

After mounting, repair or modification, etc., connect the air supply and electric power, and then confirm proper mounting by means of appropriate function and leak tests.

#### 5. Instruction manual

The product should be mounted and operated after thoroughly reading the manual and understanding its contents.

Keep the instruction manual where it can be referred to as needed.

## Piping

### ⚠ Caution

#### 1. Preparation before piping

Before piping is connected, it should be thoroughly blown out with air (flushing) or washed to remove chips, cutting oil and other debris from inside the pipe.

#### 2. Wrapping of sealant tape

When connecting pipes and fittings, etc., be certain that chips from the pipe threads and sealing material do not get inside the piping.

Also, when sealant tape is used, leave 1.5 to 2 thread ridges exposed at the end of the threads.

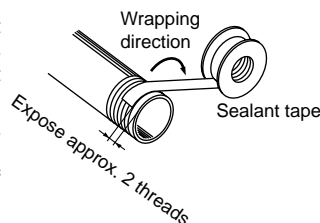

## Lubrication

### ⚠ Caution

#### 1. Lubrication of cylinder

The cylinder has been lubricated for life at the factory and can be used without any further lubrication.

However, in the event that it will be lubricated, use class 1 turbine oil (with no additives) ISO VG32.

Stopping lubrication later may lead to malfunction due to the loss of the original lubricant. Therefore, lubrication must be continued once it has been started.

## Air Supply

### ⚠ Warning

#### 1. Use clean air.

If compressed air includes chemicals, synthetic oils containing organic solvents, salts or corrosive gases, etc., it can cause damage or malfunction.

### ⚠ Caution

#### 1. Install air filters.

Install air filters at the upstream side of valves. The filtration degree should be 5µm or finer.

#### 2. Install an air dryer, after-cooler or water separator, etc.

Air that includes excessive drainage may cause malfunction of valves and other pneumatic equipment. To prevent this, install an air dryer, after-cooler or water separator, etc.

#### 3. Use the product within the specified range of fluid and ambient temperature.

Take measures to prevent freezing, since moisture in circuits will be frozen under 5°C, and this may cause damage to seals and lead to malfunction.

Refer to SMC's "Air Cleaning Equipment" catalog for further details on compressed air quality.

## Operating Environment

### ⚠ Warning

#### 1. Do not use in environments where there is a danger of corrosion.

Refer to the construction drawings regarding cylinder materials.

#### 2. In dusty locations or where water, oil, etc., splash on the equipment, install a protective cover, etc.

Contact SMC in cases where dust or water, etc., will be scattered throughout the area.

## Maintenance

### ⚠ Warning

#### 1. Perform maintenance and inspections according to the procedure indicated in the instruction manual.

If handled improperly, malfunction and damage of machinery or equipment may occur.

#### 2. Removal of components and supply/exhaust of compressed air

When components are removed, first check measures to prevent dropping of driven objects and run-away of equipment, etc. Then cut off the supply pressure and electric power, and exhaust all compressed air from the system.

When machinery is restarted, confirm lurch prevention measures and proceed with caution.

### ⚠ Caution

#### 1. Drain flushing

Remove drainage from air filters regularly. (Refer to specifications.)



# Series REA/REB Specific Product Precautions 1

Be sure to read before handling.

Refer to pages 92 through 94 for safety instruction and actuator precautions.

## Disassembly and Maintenance

### Warning

1. Use caution as the attractive force of the magnets is very strong.

When removing the external slider and piston slider from the cylinder tube for maintenance, etc., handle with caution, since the magnets installed in each slider have a very strong attractive force.

### Caution

1. Use caution when removing the external slider, as the piston slider will be directly attracted to it.

When removing the external slider or piston slider from the cylinder tube, first force the sliders out of their magnetically coupled positions, and then remove them individually when there is no longer any holding force. If they are removed while still magnetically coupled, they will be directly attracted to one another and will not come apart.

2. Do not disassemble the magnetic components (piston slider, external slider).

This can cause a loss of holding force and malfunction.

3. When disassembling to replace the seals and wear ring, refer to the separate disassembly instructions.

4. Note the direction of the external slider and piston slider.

Since the external slider and piston slider are directional for size  $\varnothing 10$ , refer to the drawings below when performing disassembly or maintenance. Put the external slider and piston slider together, and insert the piston slider into the cylinder tube so that they will have the correct positional relationship as shown in Figure 1. If they align as shown in Figure 2, reinsert the piston slider only, after turning it around 180°. If the direction is not correct, it will be impossible to obtain the specified holding force.

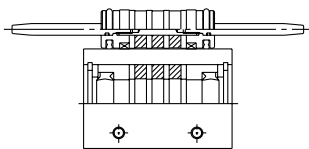

Figure 1. Correct position

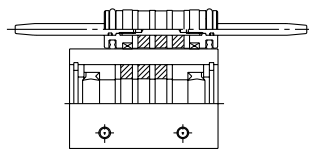

Figure 2. Incorrect position

5. During disassembly, use caution in handling the cushion ring.

The cushion ring is a precision part, and any deformation, etc., can cause malfunction or poor performance.

## Speed adjustment

### Caution

1. SMC's "throttle" type speed controllers (Series AS) are recommended for speed adjustment. (Refer to Table 3.)
2. Speed adjustment is possible with meter-in/meter-out type speed controllers, but it may not be possible to obtain the cushion effect (smooth start-up, soft stop).
3. In case of other than horizontal mounting, it is recommended that the system have a reduced pressure supply circuit installed at its lower side. (This is also effective as a countermeasure against start-up delay on an upward stroke, and for air conservation.)

Table 3. Recommended speed controllers

Bore size (mm)	Model		
	Elbow type	Straight type	In-line type
10	AS1201F-M5-04-X214	AS1301F-M5-04-X214	AS1001F-04-X214
15	AS1201F-M5-04-X214	AS1301F-M5-04-X214	AS1001F-04-X214
20	AS2201F-01-06-X214	AS2301F-01-06-X214	AS2001F-06-X214
25	AS2201F-01-06-X214	AS2301F-01-06-X214	AS2001F-06-X214
32	AS2201F-01-06-X214	AS2301F-01-06-X214	AS2001F-06-X214
40	AS2201F-02-06-X214	AS2301F-02-06-X214	AS2001F-06-X214
50	AS3201F-02-08-X214	AS3301F-02-08-X214	AS3001F-08-X214
63	AS3201F-02-08-X214	AS3301F-02-08-X214	AS3001F-08-X214

## Adjustment of Cushion Effect (Smooth Start-up, Soft Stop)

### Caution

The cushion cannot be adjusted.

There is no cushion needle adjustment of the kind found on conventional cushion mechanisms.



# Series REA/REB Auto Switch Precautions 1

Be sure to read before handling.

## Design and Selection

### ⚠ Warning

#### 1. Confirm the specifications.

Read the specifications carefully and use this product appropriately. The product may be damaged or malfunction if it is used outside the range of specifications of current load, voltage, temperature or impact.

#### 2. Take precautions when multiple cylinders are used close together.

When multiple auto switch cylinders are used in close proximity, magnetic field interference may cause the switches to malfunction. Maintain a minimum cylinder separation of 40mm. (When the allowable separation is indicated for each cylinder series, use the specified value.)

#### 3. Pay attention to the length of time that a switch is ON at an intermediate stroke position.

When an auto switch is placed at an intermediate position of the stroke and a load is driven at the time the piston passes, the auto switch will operate, but if the speed is too great the operating time will be shortened and the load may not operate properly. The maximum detectable piston speed is:

$$V(\text{mm/s}) = \frac{\text{Auto switch operating range (mm)}}{\text{Load operating time (ms)}} \times 1000$$

In cases of high piston speed, the use of an auto switch (F7NT) with a built-in OFF delay timer (approx. 200ms) makes it possible to extend the load operating time.

#### 4. Keep wiring as short as possible.

##### <Reed switch>

As the length of the wiring to a load gets longer, the in-rush current at switching ON becomes greater, and this may shorten the product's life. (The switch will stay ON all the time.)

- 1) For an auto switch without a contact protection circuit, use a contact protection box when the wire length is 5m or longer.
- 2) Even if an auto switch has a built-in contact protection circuit, when the wiring is more than 30m long, it is not able to adequately absorb the in-rush current and its life may be reduced. It is again necessary to connect a contact protection box in order to extend its life. Please contact SMC in this case.

##### <Solid state switch>

- 3) Although wire length should not affect switch function, use a wire 100m or shorter.

#### 5. Take precautions for the internal voltage drop of the switch.

##### <Reed switch>

- 1) Switches with an indicator light (Except A76H, A96 and Z76)
  - If auto switches are connected in series as shown below, take note that there will be a large voltage drop because of internal resistance in the light emitting diodes. (Refer to internal voltage drop in the auto switch specifications.)

[The voltage drop will be "n" times larger when "n" auto switches are connected.]

Even though an auto switch operates normally, the load may not operate.

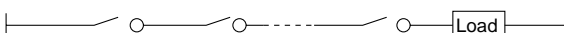

### ⚠ Warning

- In the same way, when operating below a specified voltage, although an auto switch may operate normally, the load may not operate. Therefore, the formula below should be satisfied after confirming the minimum operating voltage of the load.

$$\text{Supply voltage} - \text{Internal voltage drop of switch} > \text{Minimum operating voltage of load}$$

- 2) If the internal resistance of a light emitting diode causes a problem, select a switch without an indicator light (Model A80, A80H, A90 and Z80).

##### <Solid state switch>

- 3) Generally, the internal voltage drop will be greater with a 2 wire solid state auto switch than with a reed switch. Take the same precautions as in 1).

Also, note that a 12VDC relay is not applicable.

#### 6. Pay attention to leakage current.

##### <Solid state switch>

With a 2 wire solid state auto switch, current (leakage current) flows to the load to operate the internal circuit even when in the OFF state.

$$\text{Operating current of load (OFF condition)} > \text{Leakage current}$$

If the criteria given in the above formula are not met, it will not reset correctly (stays ON). Use a 3 wire switch if this specification will not be satisfied.

Moreover, leakage current flow to the load will be "n" times larger when "n" auto switches are connected in parallel.

#### 7. Do not use a load that generates surge voltage.

##### <Reed switch>

If driving a load such as a relay that generates a surge voltage, use a switch with a built-in contact protection circuit or use a contact protection box.

##### <Solid state switch>

Although a zener diode for surge protection is connected at the output side of a solid state auto switch, damage may still occur if the surge is applied repeatedly. When a load, such as a relay or solenoid, which generates surge is directly driven, use a type of switch with a built-in surge absorbing element.

#### 8. Cautions for use in an interlock circuit.

When an auto switch is used for an interlock signal requiring high reliability, devise a double interlock system to avoid trouble by providing a mechanical protection function, or by also using another switch (sensor) together with the auto switch. Also perform periodic maintenance and confirm proper operation.

#### 9. Ensure sufficient clearance for maintenance activities.

When designing an application, be sure to allow sufficient clearance for maintenance and inspections.



# Series REA/REB Auto Switch Precautions 2

Be sure to read before handling.

## Mounting and Adjustment

### ⚠ Warning

#### 1. Do not drop or bump.

Do not drop, bump or apply excessive impacts (300m/s<sup>2</sup> or more for reed switches and 1000m/s<sup>2</sup> or more for solid state switches) while handling.

Although the body of the switch may not be damaged, the inside of the switch could be damaged and cause a malfunction.

#### 2. Do not carry a cylinder by the auto switch lead wires.

Never carry a cylinder by its lead wires. This may not only cause broken lead wires, but it may cause internal elements of the switch to be damaged by the stress.

#### 3. Mount switches using the proper tightening torque.

When a switch is tightened beyond the range of tightening torque, the mounting screws, mounting bracket or switch may be damaged. On the other hand, tightening below the range of tightening torque may allow the switch to slip out of position. (Refer to switch mounting for each series regarding switch mounting, moving, and tightening torque, etc.)

#### 4. Mount a switch at the center of the operating range.

Adjust the mounting position of an auto switch so that the piston stops at the center of the operating range (the range in which a switch is ON).

(The mounting position shown in a catalog indicates the optimum position at stroke end.) If mounted at the end of the operating range (around the borderline of ON and OFF), operation will be unstable.

## Wiring

### ⚠ Warning

#### 1. Avoid repeatedly bending or stretching lead wires.

Broken lead wires will result from repeatedly applying bending stress or stretching force to the lead wires.

#### 2. Be sure to connect the load before power is applied.

<2 wire type>

If the power is turned ON when an auto switch is not connected to a load, the switch will be instantly damaged because of excess current.

#### 3. Confirm proper insulation of wiring.

Be certain that there is no faulty wiring insulation (contact with other circuits, ground fault, improper insulation between terminals, etc.). Damage may occur due to excess current flow into a switch.

#### 4. Do not wire with power lines or high voltage lines.

Wire separately from power lines or high voltage lines, avoiding parallel wiring or wiring in the same conduit with these lines. Control circuits containing auto switches may malfunction due to noise from these other lines.

## Wiring

### ⚠ Warning

#### 5. Do not allow short circuit of loads.

<Reed switch>

If the switch will be instantly damaged because of excess current flow into the switch.

<Solid state switch>

Models D-F9□, F-9□W and all models of PNP output type switches do not have built-in short circuit protection circuits. If loads are short circuited, the switches will be instantly damaged, as in the case of reed switches.

\* Take special care to avoid reverse wiring with the brown [red] power supply line and the black [white] output line on 3 wire type switches.

#### 6. Avoid incorrect wiring.

<Reed switch>

A 24VDC switch with indicator light has polarity. The brown [red] lead wire or terminal No. 1 is (+), and the blue [black] lead wire or terminal No. 2 is (-).

[In the case of model D-97, the side without indicator is (+), and the black line side is (-).]

1) If connections are reversed, a switch will operate, however, the light emitting diode will not light up.

Also note that a current greater than that specified will damage a light emitting diode and it will no longer operate.

Applicable models: D-A73, A73H, A73C, Z73, D-A93

<Solid state switch>

1) If connections are reversed on a 2 wire type switch, the switch will not be damaged if protected by a protection circuit, but the switch will always stay in an ON state. However, it is still necessary to avoid reversed connections, since the switch could be damaged by a load short circuit in this condition.

2) If connections are reversed (power supply line + and power supply line -) on a 3 wire type switch, the switch will be protected by a protection circuit. However, if the power supply line (+) is connected to the blue [black] wire and the power supply line (-) is connected to the black [white] wire, the switch will be damaged.

#### \* Lead wire color changes

Lead wire colors of SMC switches have been changed in order to meet NECA Standard 0402 for production beginning September, 1996 and thereafter. Please refer to the tables provided.

Special care should be taken regarding wire polarity during the time that the old colors still coexist with the new colors.

#### 2 wire

	Old	New
Output (+)	Red	Brown
Output (-)	Black	Blue

#### 3 wire

	Old	New
Power supply	Red	Brown
GND	Black	Blue
Output	White	Black

#### Solid state with diagnostic output

	Old	New
Power supply	Red	Brown
GND	Black	Blue
Output	White	Black
Diagnostic Output	Yellow	Orange

#### Solid state with latch type diagnostic output

	Old	New
Power supply	Red	Brown
GND	Black	Blue
Output	White	Black
Latch type diagnostic Output	Yellow	Orange

Note) Lead wire colors inside [ ] are those prior to conformity with IEC standards.



# Series REA/REB Auto Switch Precautions 3

Be sure to read before handling.

## Operating Environment

### ⚠ Warning

#### 1. Never use in an atmosphere of explosive gases.

The construction of auto switches is not intended to prevent explosion. Never use in an atmosphere with an explosive gas since this may cause a serious explosion.

#### 2. Do not use in an area where a magnetic field is generated.

Auto switches will malfunction or magnets inside cylinders will become demagnetized. (Consult SMC regarding the availability of a magnetic field resistant auto switch.)

#### 3. Do not use in an environment where the auto switch will be continually exposed to water.

Although switches satisfy the IEC standard IP67 construction (JIS C 0920: watertight construction), do not use switches in applications where continually exposed to water splash or spray. Poor insulation or swelling of the potting resin inside switches may cause malfunction.

#### 4. Do not use in an environment with oil or chemicals.

Consult SMC if auto switches will be used in an environment with coolant, cleaning solvent, various oils or chemicals. If auto switches are used under these conditions for even a short time, they may be adversely affected by improper insulation, malfunction due to swelling of the potting resin, or hardening of the lead wires.

#### 5. Do not use in an environment with temperature cycles.

Consult SMC if switches are used where there are temperature cycles other than normal air temperature changes, as they may be adversely affected.

#### 6. Do not use in an environment where there is excessive impact shock.

##### <Reed switch>

When excessive impact (300m/s<sup>2</sup> or more) is applied to a reed switch during operation, the contact point will malfunction and generate or cut off a signal momentarily (1ms or less). Consult SMC regarding the need to use a solid state switch depending upon the environment.

#### 7. Do not use in an area where surges are generated.

##### <Solid state switch>

When there are units (solenoid type lifter, high frequency induction furnace, motor, etc.) which generate a large amount of surge in the area around cylinders with solid state auto switches, this may cause deterioration or damage to the switch. Avoid sources of surge generation and crossed lines.

#### 8. Avoid accumulation of iron waste or close contact with magnetic substances.

When a large amount of ferrous waste such as machining chips or spatter is accumulated, or a magnetic substance (something attracted by a magnet) is brought into close proximity with an auto switch cylinder, it may cause the auto switches to malfunction due to a loss of the magnetic force inside the cylinder.

## Maintenance

### ⚠ Warning

#### 1. Perform the following maintenance periodically in order to prevent possible danger due to unexpected auto switch malfunction.

##### 1) Securely tighten switch mounting screws.

If screws become loose or the mounting position is dislocated, retighten them after readjusting the mounting position.

##### 2) Confirm that there is no damage to lead wires.

To prevent faulty insulation, replace switches or repair lead wires, etc., if damage is discovered.

##### 3) Confirm the lighting of the green light on the 2 color indicator type switch.

Confirm that the green LED is on when stopped at the established position. If the red LED is on, the mounting position is not appropriate. Readjust the mounting position until the green LED lights up.

## Other

### ⚠ Warning

#### 1. Consult SMC concerning water resistance, elasticity of lead wires, and usage at welding sites, etc.





## SMC'S GLOBAL MANUFACTURING, DISTRIBUTION AND SERVICE NETWORK

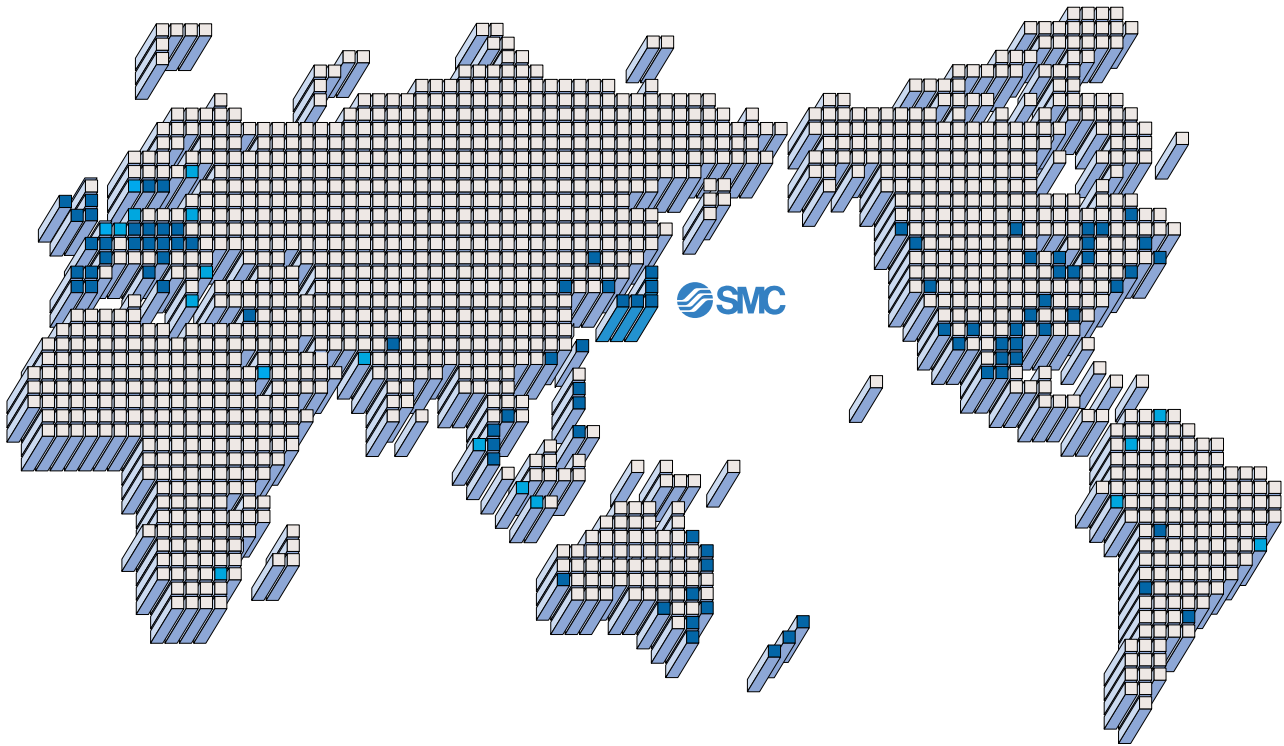

### EUROPE

#### AUSTRIA

SMC Pneumatik GmbH

#### CZECH

SMC Czech s.r.o.

#### DENMARK

SMC Pneumatik A/S

#### FINLAND

SMC Pneumatiikka OY

#### FRANCE

SMC Pneumatique SA

#### GERMANY

SMC Pneumatik GmbH

#### HUNGARY

SMC Hungary Kft.

#### IRELAND

SMC Pneumatics (Ireland) Ltd.

#### ITALY

SMC Italia S.p.A.

#### NETHERLANDS

SMC Pneumatics BV.

#### NORWAY

SMC Pneumatics Norway A/S

#### POLAND

SMC Industrial Automation Polska Sp.z.o.o.

#### ROMANIA

SMC Romania s.r.l.

#### RUSSIA

SMC Pneumatik LLC.

#### SLOVAKIA

SMC Slovakia s.r.o.

### EUROPE

#### SLOVENIA

SMC Slovenia d.o.o.

#### SPAIN/PORTUGAL

SMC España, S.A.

#### SWEDEN

SMC Pneumatics Sweden AB

#### SWITZERLAND

SMC Pneumatik AG.

#### UK

SMC Pneumatics (U.K.) Ltd.

### ASIA

#### CHINA

SMC (China) Co., Ltd.

#### HONG KONG

SMC Pneumatics (Hong Kong) Ltd.

#### INDIA

SMC Pneumatics (India) Pvt. Ltd.

#### MALAYSIA

SMC Pneumatics (S.E.A.) Sdn. Bhd.

#### PHILIPPINES

SMC Pneumatics (Philippines), Inc.

#### SINGAPORE

SMC Pneumatics (S.E.A.) Pte. Ltd.

#### SOUTH KOREA

SMC Pneumatics Korea Co., Ltd.

#### TAIWAN

SMC Pneumatics (Taiwan) Co., Ltd.

#### THAILAND

SMC Thailand Ltd.

### NORTH AMERICA

#### CANADA

SMC Pneumatics (Canada) Ltd.

#### MEXICO

SMC Corporation (Mexico) S.A. de C.V.

#### USA

SMC Corporation of America

### SOUTH AMERICA

#### ARGENTINA

SMC Argentina S.A.

#### BOLIVIA

SMC Pneumatics Bolivia S.R.L.

#### BRAZIL

SMC Pneumaticos Do Brazil Ltda.

#### CHILE

SMC Pneumatics (Chile) S.A.

#### VENEZUELA

SMC Neumatica Venezuela S.A.

### OCEANIA

#### AUSTRALIA

SMC Pneumatics (Australia) Pty. Ltd.

#### NEW ZEALAND

SMC Pneumatics (N.Z.) Ltd.

## SMC CORPORATION

1-16-4 Shimbashi, Minato-ku, Tokyo 105-0004, JAPAN

Tel: 03-3502-2740 Fax: 03-3508-2480

URL <http://www.smcworld.com>

© 2001 SMC CORPORATION All Rights Reserved

1st printing February, 2001 D-SMC.L.A. P-80 (JT)

This catalog is printed on recycled paper with concern for the global environment.

All specifications in this catalog are subject to change without notice.

Printed in Japan.