

Smooth Cylinder

CQSY/CQ2Y/CM2Y/CG1Y/CA2Y

ø12 to ø25 ø32 to ø100 ø20 to ø40 ø20 to ø100 ø40 to ø100



Minimum operating pressure 0.01 to 0.03 MPa

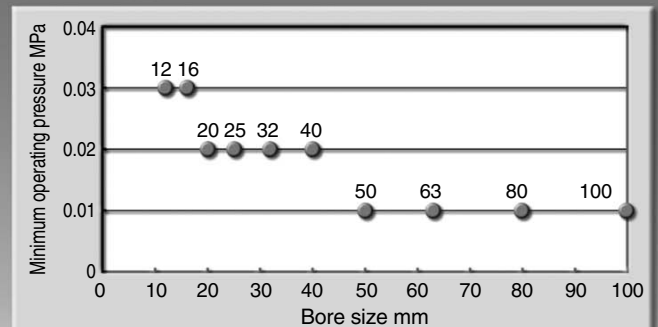

(Measurement based on JIS B8377)

Stable operation possible even at a low speed of 5 mm/s (Measurement based on JIS B 8377)

Smooth operation with less sticking and slipping

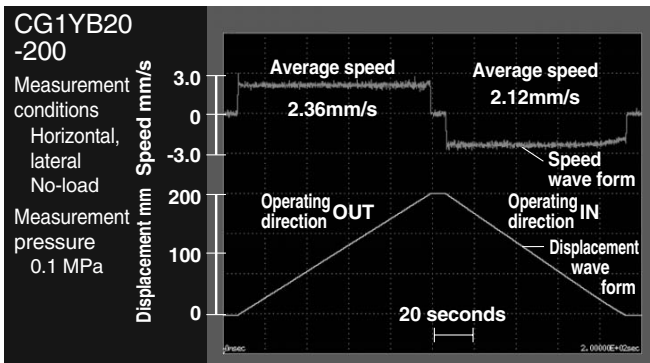
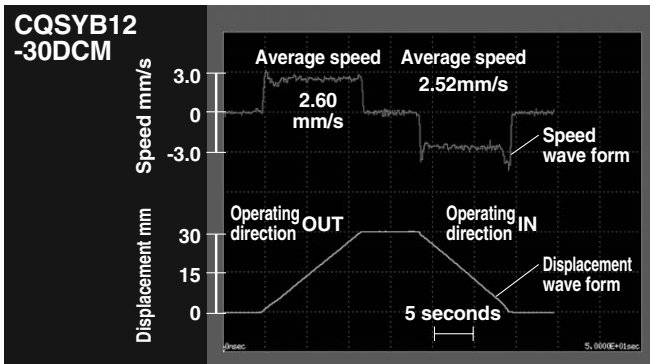

Sliding resistance

Bi-directional low-friction operation possible.
Pressure can be controlled regardless of its direction.

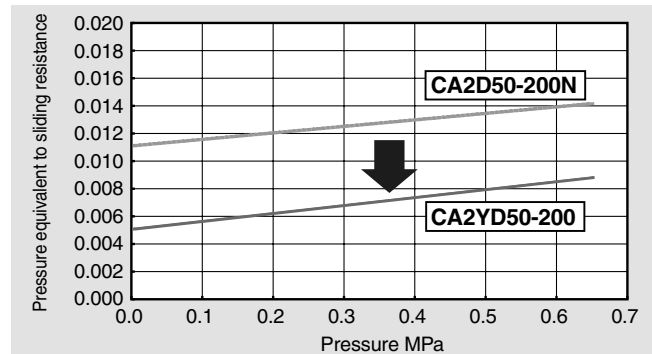

Application Example

Smooth cylinder combined with precision regulator (e.g. Series IR)

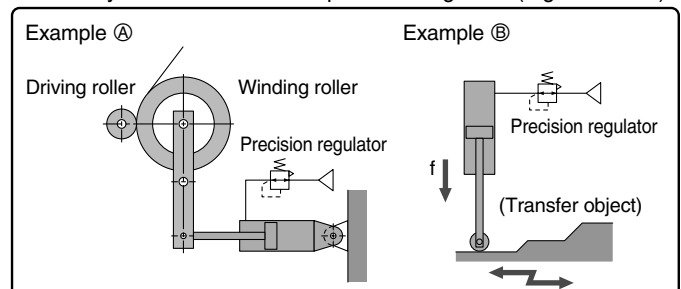

RE^A_B

REC

C□X

C□Y

MQ^Q_M

RHC

MK(2)

RS^Q_G

RS^H_A

RZQ

MI^W_S

CEP1

CE1

CE2

ML2B

C¹/₅-S

CV

MVGQ

CC

RB

J

D-

-X

20-

Data

Smooth Cylinder Series CQSY

ø12, ø16, ø20, ø25



Specifications and auto switch information not provided below are the same as those of the anti-lateral load type of Series CQS□S. Please refer to page of Best Pneumatics Vol. 7.

How to Order

Without auto switch

CQSY B 20 30 D C

With auto switch

CDQSY B 20 30 D C F9BW S

Built-in magnet

Mounting style

B	Through-hole/Both ends tapped (Standard)
L	Foot style
F	Front flange style
G	Rear flange style
D	Double clevis style

* Mounting brackets are not mounted and are supplied loose at the time of shipment.

Bore size

12	12 mm
16	16 mm
20	20 mm
25	25 mm

Cylinder stroke (mm)

Refer to "Standard Stroke" on page 10-4-3.

Number of auto switches

Nil	2 pcs.
S	1 pc.
n	n pcs.

Auto switch

Nil	Without auto switch (Built-in magnet)
------------	---------------------------------------

* For the applicable auto switch model, refer to the table below.

* Auto switches are not mounted and are supplied loose at the time of shipment.

Note) Please also confirm whether the selected auto switch can be mounted at the desired position. Auto switches of models A9□V and M9□V may not be mounted on the side with ports due to the cylinder stroke or the size of the fittings.

Bumper/Rod end thread

C	Rubber bumper & Rod end female thread
CM	Rubber bumper & Rod end male thread

Action

D	Double acting
----------	---------------

Applicable Auto Switch/Refer to page 10-20-1 for further information on auto switches.

Type	Special function	Electrical entry	Indicator light	Wiring (Output)	Load voltage			Auto switch model		Lead wire (m)*			Pre-wired connector	Applicable load			
					DC	AC		Perpendicular	In-line	0.5 (Nil)	3 (L)	5 (Z)					
Reed switch	—	Grommet	Yes	3-wire (Equiv. NPN)	—	5 V	—	A96V	A96	●	●	—	—	IC	—		
				2-wire	24 V	12 V	100 V	A93V	A93	●	●	—	—	—	—	Relay, PLC	
Solid state switch	—	Grommet	Yes	3-wire (NPN)	24 V	5 V, 12 V	—	—	M9N	●	●	—	—	IC	Relay, PLC		
				3-wire (PNP)				—	M9P	●	●	—	—				
				2-wire				—	M9B	●	●	—	—				
				3-wire (NPN)				—	M9NV	●	●	○	○				
	3-wire (PNP)			—	M9PV	●		●	○	○							
	2-wire			—	M9BV	●		●	○	○							
	Diagnostic indication (2-color)			3-wire (NPN)	24 V	5 V, 12 V		F9NWV	F9NW	●	●	○	○	—		—	IC
				3-wire (PNP)				F9PWV	F9PW	●	●	○	○	—		—	
	Water resistant (2-color)			3-wire (NPN)	24 V	5 V, 12 V		F9BWV	F9BW	●	●	○	○	—		—	—
				2-wire				12 V	—	F9BA	—	●	○	○		—	—

* Lead wire length symbols: 0.5 m Nil (Example) A93
 3 m L (Example) A93L
 5 m Z (Example) F9NWZ

* ○: Manufactured upon receipt of order.

In addition to the models in the above table, there are some other auto switches that are applicable. For more information, refer to page of Best Pneumatics Vol. 7.

Smooth Cylinder Series CQSY



JIS Symbol

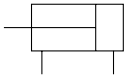

Specifications

Type	Pneumatic (Non-lube)
Action	Double acting, Single rod
Fluid	Air
Proof pressure	1.05 MPa
Maximum operating pressure	0.7 MPa
Ambient and fluid temperature	Without auto switch -10 to 70°C (with no freezing) With auto switch -10 to 60°C (with no freezing)
Cushion	Rubber bumper
Rod end thread	Female thread
Rod end thread tolerance	JIS class 2
Stroke length tolerance	$\begin{matrix} +1.0 \\ 0 \end{matrix}$
Mounting	Through-hole/Both ends tapped common
Operating piston speed	5 to 500 mm/s
Allowable leakage rate	0.5 μ /min (ANR) or less

Minimum Operating Pressure

Bore size (mm)	Unit: MPa			
	12	16	20	25
Minimum operating pressure	0.03		0.02	

Standard Stroke

Bore size (mm)	Standard stroke (mm)
12, 16	5, 10, 15, 20, 25, 30
20, 25	5, 10, 15, 20, 25, 30, 35, 40, 45, 50

Replacement Parts: Seal Kit

Bore size (mm)	Kit no.	Contents
12	CQSY12-PS	Piston seal 1 pc.
16	CQSY16-PS	Rod seal 1 pc.
20	CQSY20-PS	Tube gasket 1 pc.
25	CQSY25-PS	Grease pack (10 g) 1 pc.

When only grease for maintenance is necessary, please order by the following part numbers.

Grease pack GR-L-005 (5 g)
GR-L-010 (10 g)

Theoretical Output

Bore size (mm)	Rod size (mm)	Operating direction	Piston area (mm ²)	Operating pressure (MPa)		
				0.3	0.5	0.7
				Unit: N		
12	6	IN	84.8	25	42	59
		OUT	113	34	57	79
16	8	IN	151	45	75	106
		OUT	201	60	101	141
20	10	IN	236	71	118	165
		OUT	314	94	157	220
25	12	IN	378	113	189	264
		OUT	491	147	245	344

Intermediate Stroke

Method	Installation of spacer on standard stroke body.		
Model no.	Refer to page 10-4-2 for standard model no.		
Standard stroke	Method	Intermediate strokes at 1 mm intervals are available by using spacers with standard stroke cylinders.	
	Stroke range	Bore size (mm)	Stroke range (mm)
		12, 16	1 to 29
20, 25	1 to 49		
Example	Part no.: CQSYB25-47DC CQSYB25-50DC with 3 mm width spacer inside. B dimension is 77.5 mm. Calculation: $\phi 25$, B dimension 27.5 mm (without switch) $27.5 \text{ (B dimension)} + 50 \text{ (st)} = 77.5 \text{ (mm)}$		

Series CQSY

Dimensions/ø12 to ø25

Basic style
(Through-hole/Both ends tapped):
CQSYB/CDQSYB



Specifications and auto switch information not provided below are the same as those of the **anti-lateral load type of Series CQS□S**. Please refer to page of Best Pneumatics Vol. 7.

ø12

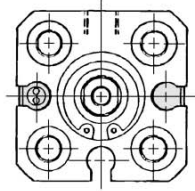

ø16

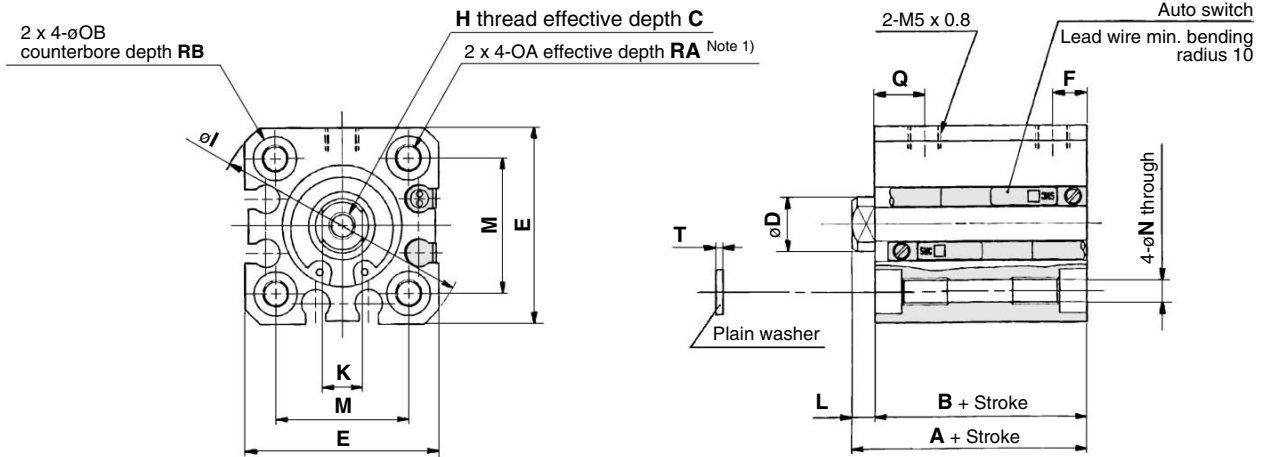

ø20, ø25

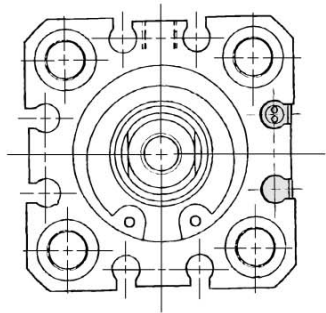

Rod end male thread

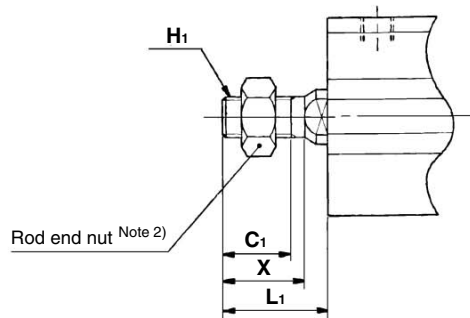

Rod End Male Thread (mm)

Bore size (mm)	C ₁	H ₁	L ₁	X
12	9	M5 x 0.8	14	10.5
16	10	M6 x 1.0	15.5	12
20	12	M8 x 1.25	18.5	14
25	15	M10 x 1.25	22.5	17.5

Basic Style (mm)

Bore size (mm)	Stroke range (mm)	Without auto switch		With auto switch		C	D	E	F	H	I	K	L	M	N	OA	OB	Q	RA	RB	T
		A	B	A	B																
12	5 to 30	25.5	22	30.5	27	6	6	25	5	M3 x 0.5	32	5	3.5	15.5	3.5	M4 x 0.7	6.5	7.5	7	4	0.5
16	5 to 30	25.5	22	30.5	27	8	8	29	5	M4 x 0.7	38	6	3.5	20	3.5	M4 x 0.7	6.5	7.5	7	4	0.5
20	5 to 50	29	24.5	39	34.5	7	10	36	5.5	M5 x 0.8	47	8	4.5	25.5	5.4	M6 x 1.0	9	9	10	7	1
25	5 to 50	32.5	27.5	42.5	37.5	12	12	40	5.5	M6 x 1.0	52	10	5	28	5.4	M6 x 1.0	9	11	10	7	1

Note 1) Threaded through hole is used for the standard of ø20 with 5 to 10 mm strokes and ø25 with a 5 mm stroke.

Note 2) For more information about the rod end nut and accessories, please refer to page of Best Pneumatics Vol. 7.

Smooth Cylinder Series CQ2Y

ø32, ø40, ø50, ø63, ø80, ø100



Specifications and auto switch information not provided below are the same as those of the anti-lateral load type of Series CQ2□S. Please refer to page of Best Pneumatics Vol. 7.

How to Order

Without auto switch

CQ2Y B 32 □ — 30 D C □

With auto switch

CDQ2Y B 32 □ — 30 D C □ — F9BW S

Built-in magnet

Mounting style

B	Through-hole (Standard)
A	Both ends tapped
L	Foot style
F	Front flange style
G	Rear flange style
D	Double clevis style

* Mounting brackets are not mounted and are supplied loose at the time of shipment.

Bore size

32	32 mm
40	40 mm
50	50 mm
63	63 mm
80	80 mm
100	100 mm

Thread type

Nil	Rc
TN	NPT
TF	G

Cylinder stroke (mm)

Refer to "Standard Stroke" on page 10-4-6.

Action

D	Double acting
---	---------------

Cushion

C	Rubber bumper
---	---------------

Body option

Nil	Standard (Rod end female thread)
M	Rod end male thread

Number of auto switches

Nil	2 pcs.
S	1 pc.
n	n pcs.

Auto switch

Nil	Without auto switch (Built-in magnet)
-----	---------------------------------------

* For the applicable auto switch model, refer to the table below.
* Auto switches are not mounted and are supplied loose at the time of shipment (Except D-P5DWL).

Applicable Auto Switch/Refer to page 10-20-1 for further information on auto switches.

Type	Special function	Electrical entry	Indicator light	Wiring (Output)	Load voltage		Rail mounting		Direct mounting		Lead wire (m)*				Pre-wire connector	Applicable load			
					DC	AC	ø12 to ø100	ø32 to ø100	0.5 (Nil)	3 (L)	5 (Z)	None (N)	Relay, PLC	IC					
Reed switch	-	Grommet	Yes	3-wire (Equiv. NPN)	-	5 V	-	A76H	A96V	A96	●	●			-	-	-	IC	-
				2-wire	-	-	200 V	A72	A72H	-	-	●	●	-	-	-	-	-	Relay, PLC
					24 V	12 V	100 V	A73	A73H	-	-	●	●	●	-	-	-		
					12 V	-	-	A73C	-	-	-	●	●	●	●	-	-		
Diagnostic indication (2-color)	Grommet	Yes	-	-	-	A79W	-	-	-	●	●	-	-	-	-	-			
Solid state switch	-	Grommet	Yes	3-wire (NPN)	24 V	5V, 12V	-	F7NV	F79	-	-	●	●	○	-	○	IC		
				3-wire (PNP)				F7PV	F7P	-	-	●	●	○	-	○	IC		
				2-wire				F7BV	J79	-	-	●	●	○	-	○	-	-	
		Grommet		3-wire (NPN)				-	-	M9NV	M9N	●	●	○	-	○	IC		
				3-wire (PNP)				-	-	M9NV	M9P	●	●	○	-	○	IC		
				2-wire				-	-	M9NV	M9B	●	●	○	-	○	-	-	
	Diagnostic indication (2-color)	Grommet	Yes	3-wire (NPN)	24 V	5V, 12V	-	F7NWX	F79W	F9NWX	F9NW	●	●	○	-	○	IC		
				3-wire (PNP)				-	F7PW	F9PWV	F9PW	●	●	○	-	○	IC		
				2-wire				F7BWX	J79W	F9BWX	F9BW	●	●	○	-	○	-	-	
	Water resistant (2-color)	Grommet	Yes	2-wire	24 V	12 V	-	-	F7BA	-	F9BA	-	●	○	-	○	-	-	
				4-wire (NPN)				-	F79F	-	-	-	●	○	-	○	IC		
				2-wire				-	P5DW	-	-	-	●	●	-	○	-	-	

* Lead wire length symbols: 0.5 m Nil (Example) A73C
 3 m L (Example) A73CL
 5 m Z (Example) A73CZ
 None N (Example) A73CN

* ○: Manufactured upon receipt of order.

D-P5DWL is available for ø40 to ø100.

In addition to the models in the above table, there are some other auto switches that are applicable. For more information, please consult with SMC.

RE^A_B

REC

C□X

C□Y

MQ^Q_M

RHC

MK(2)

RS^Q_G

RS^H_A

RZQ

MI^W_S

CEP1

CE1

CE2

ML2B

C₆5-S

CV

MVGQ

CC

RB

J

D-

-X

20-

Data

Series CQ2Y



JIS Symbol

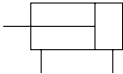

Specifications

Type	Pneumatic (Non-lube)
Fluid	Air
Proof pressure	1.05 MPa
Maximum operating pressure	0.7 MPa
Ambient and fluid temperature	Without auto switch -10 to 70°C (with no freezing) With auto switch -10 to 60°C (with no freezing)
Cushion	Rubber bumper (Standard)
Rod end thread	Female thread
Rod end thread tolerance	JIS class 2
Stroke length tolerance	$\begin{matrix} +1.0 \\ 0 \end{matrix}$
Mounting	Through-hole
Operating piston speed range	5 to 500 mm/s
Allowable leakage rate	0.5 μ /min (ANR) or less

Minimum Operating Pressure

Unit: MPa						
Bore size (mm)	32	40	50	63	80	100
Minimum operating pressure	0.02			0.01		

Standard Stroke

Bore size (mm)	Standard stroke (mm)
32, 40	5, 10, 15, 20, 25, 30, 35, 40, 45, 50, 75, 100
50, 63, 80, 100	10, 15, 20, 25, 30, 35, 40, 45, 50, 75, 100

Replacement Parts: Seal Kit

Bore size (mm)	Kit n. no.	Contents
32	CQ2Y32-PS	
40	CQ2Y40-PS	Piston seal 1 pc.
50	CQ2Y50-PS	Rod seal 1 pc.
63	CQ2Y63-PS	Gasket 1 pc.
80	CQ2Y80-PS	Grease pack (10 g) 1 pc.
100	CQ2Y100-PS	

When only grease for maintenance is necessary, please order by the following part numbers.

Grease pack GR-L-005 (5 g)
GR-L-010 (10 g)

Theoretical Output

				Unit: N
Bore size (mm)	Operating direction	Operating pressure (MPa)		
		0.3	0.5	0.7
32	IN	181	302	422
	OUT	241	402	563
40	IN	317	528	739
	OUT	377	628	880
50	IN	495	825	1155
	OUT	589	982	1374
63	IN	841	1402	1962
	OUT	935	1559	2182
80	IN	1361	2268	3175
	OUT	1508	2513	3519
100	IN	2144	3574	5003
	OUT	2356	3927	5498

Intermediate Stroke

Method		Installation of spacer on standard stroke body.	
Model no.		Refer to page 10-4-5 for standard model no.	
Standard stroke	Method	Intermediate strokes at 1 mm intervals are available by using spacers with standard stroke cylinders.	
	Stroke range	Bore size (mm) 32 to 100	Stroke range (mm) 1 to 99
Example		Part no.: CQ2YB50-57DC CQ2YB50-75DC with 18 mm width spacer inside. B dimension is 125.5 mm. Calculation: $\phi 50$, B dimension 50.5 mm (without switch) $50.5 \text{ (B dimension)} + 75 \text{ (st)} = 125.5 \text{ (mm)}$	

Smooth Cylinder Series CQ2Y

Dimensions/ø32 to ø50 (Types with auto switch and without auto switch only differ in the A and B dimensions. Please refer to the table below.)



Specifications and auto switch information not provided below are the same as those of the anti-lateral load type of Series CQ2□S. Please refer to page of Best Pneumatics Vol. 7.

Through-hole: CQ2YB/CDQ2YB

Both ends tapped style: CQ2YA/CDQ2YA

CDQ2YA

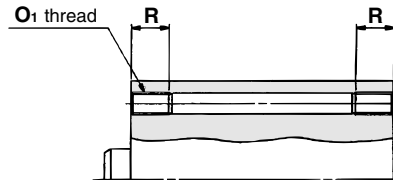

Both Ends Tapped (mm)		
Bore size (mm)	O1	R
32	M6 x 1.0	10
40	M6 x 1.0	10
50	M8 x 1.25	14

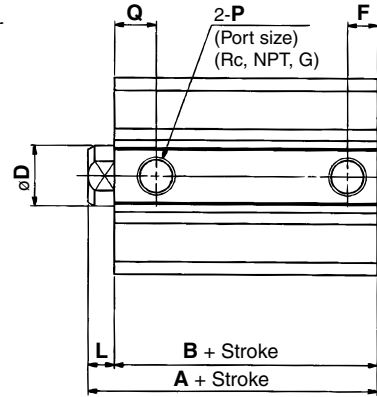
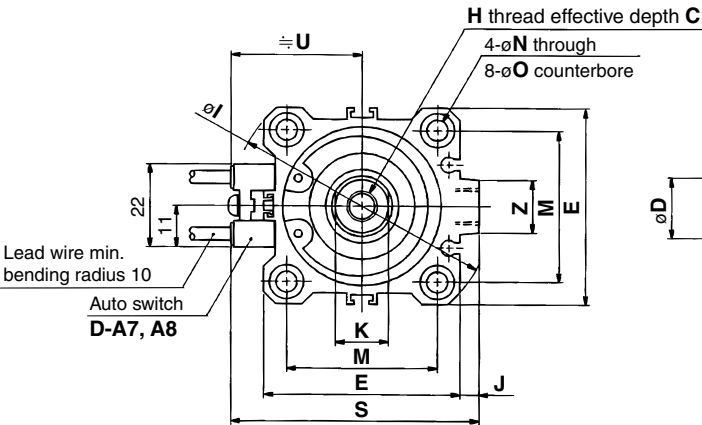

Rod end male thread

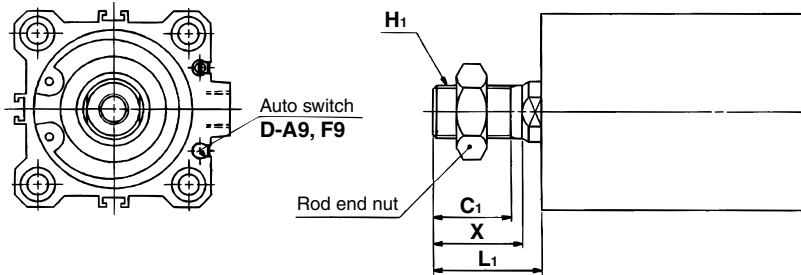

Rod End Male Thread (mm)

Bore size (mm)	C1	X	H1	L1
32	20.5	23.5	M14 x 1.5	28.5
40	20.5	23.5	M14 x 1.5	28.5
50	26	28.5	M18 x 1.5	33.5

Bore size (mm)	Stroke range (mm)	Without auto switch		With auto switch		(mm)																
		A	B	A	B	C	D	E	F	H	I	J	K	L	M	N	O	P	Q	S	U	Z
32	5 to 50	40	33	50	43	13	16	45	7.5	M8 x 1.25	60	4.5	14	7	34	5.5	9 depth 7	1/8	10.5	58.5	31.5	14
	75, 100	50	43																			
40	5 to 50	46.5	39.5	56.5	49.5	13	16	52	8	M8 x 1.25	69	5	14	7	40	5.5	9 depth 7	1/8	11	66	35	14
	75, 100	56.5	49.5																			
50	10 to 50	48.5	40.5	58.5	50.5	15	20	64	10.5	M10 x 1.5	86	7	17	8	50	6.6	11 depth 8	1/4	10.5	80	41	19
	75, 100	58.5	50.5																			

- RE^A_B
- REC
- C□X
- C□Y
- MQ^Q_M
- RHC
- MK(2)
- RS^Q_G
- RS^H_A
- RZQ
- MI^W_S
- CEP1
- CE1
- CE2
- ML2B
- C¹/₆5-S
- CV
- MVGQ
- CC
- RB
- J
- D-
- X
- 20-
- Data

Series CQ2Y

Dimensions/ø63 to ø100 (Types with auto switch and without auto switch only differ in the A and B dimensions. Please refer to the table below.)



Specifications and auto switch information not provided below are the same as those of the **anti-lateral load type of Series CQ2□S**. Please refer to page of Best Pneumatics Vol. 7.

Through-hole: CQ2YB/CDQ2YB

Both ends tapped style: CQ2YA/CDQ2YA

Both Ends Tapped (mm)

Bore size (mm)	O1	R
63	M10 x 1.5	18
80	M12 x 1.75	22
100	M12 x 1.75	22

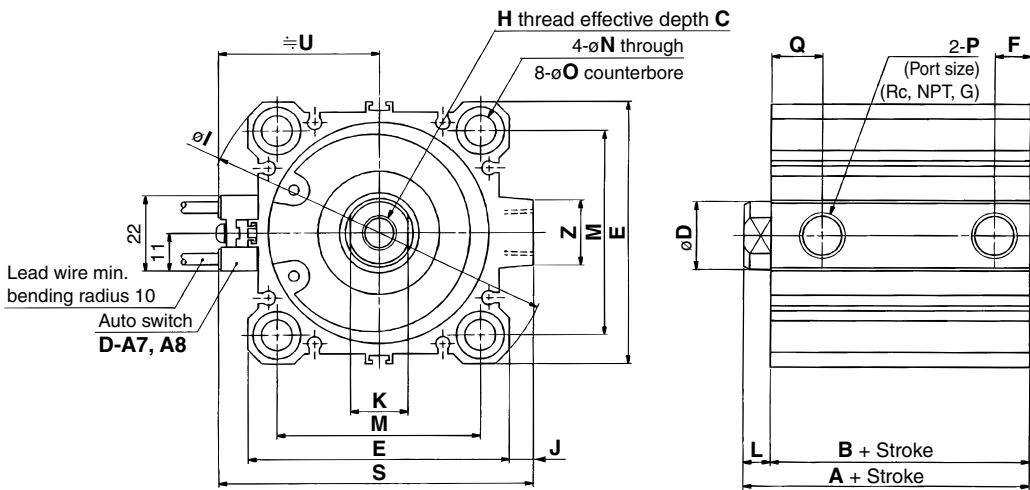
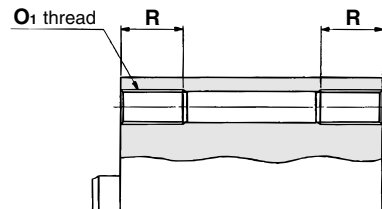

Rod end male thread

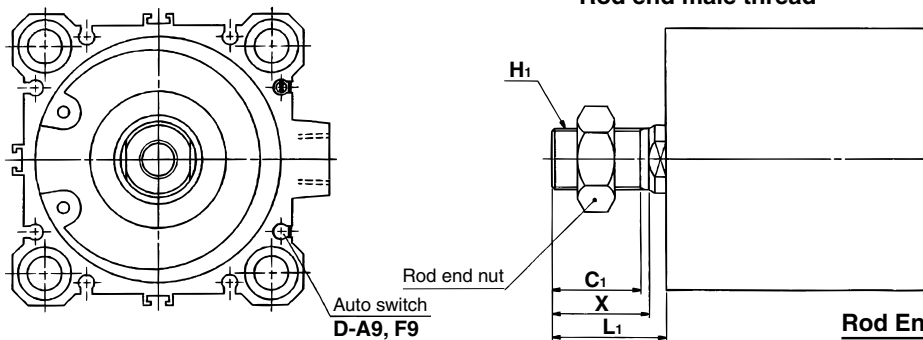

Rod End Male Thread (mm)

Bore size (mm)	C1	X	H1	L1
63	26	28.5	M18 x 1.5	33.5
80	32.5	35.5	M22 x 1.5	43.5
100	32.5	35.5	M26 x 1.5	43.5

Bore size (mm)	Stroke range (mm)	Without auto switch		With auto switch		C	D	E	F	H	I	J	K	L	M	N	O	P	Q	S	U	Z
		A	B	A	B																	
63	10 to 50	54	46	64	56	15	20	77	10.5	M10 x 1.5	103	7	17	8	60	9	14 depth 10.5	1/4	15	93	47.5	19
	75, 100	64	56																			
80	10 to 50	63.5	53.5	73.5	63.5	21	25	98	12.5	M16 x 2.0	132	6	22	10	77	11	17.5 depth 13.5	3/8	16	112.5	57.5	26
	75, 100	73.5	63.5																			
100	10 to 50	75	63	85	73	27	30	117	13	M20 x 2.5	156	6.5	27	12	94	11	17.5 depth 13.5	3/8	23	132.5	67.5	26
	75, 100	85	73																			

Smooth Cylinder Series CM2Y

ø20, ø25, ø32, ø40



Specifications and auto switch information not provided below are the same as those of the **standard, double acting, single rod type of Series CM2**. Please refer to page of Best Pneumatics Vol. 6.

How to Order

Without auto switch

CM2Y L 40 150

With auto switch

CDM2Y L 40 150 H7BW S

Built-in magnet

Mounting style

Bore size

Number of auto switches

Nil	2 pcs.
S	1 pc.
n	n pcs.

Auto switch

Nil Without auto switch (Built-in magnet)

* For the applicable auto switch model, refer to the table below.

Cylinder stroke (mm)

Refer to "Standard Stroke" on page 10-4-10.

B	Basic style
L	Axial foot style
F	Front flange style
G	Rear flange style
C	Single clevis style
D	Double clevis style
U	Front trunnion style
T	Rear trunnion style
E	Integral clevis style
BZ	Boss-cut basic style
FZ	Boss-cut front flange style
UZ	Boss-cut front trunnion style

20	20 mm
25	25 mm
32	32 mm
40	40 mm

Nil	Rc
TN	NPT
TF	G

Applicable Auto Switch/Refer to page 10-20-1 for further information on auto switches.

Type	Special function	Electrical entry	Indicator light	Wiring (Output)	Load voltage		Auto switch model	Lead wire (m)*				Pre-wire connector	Applicable load		
					DC	AC		0.5 (Nil)	3 (L)	5 (Z)	None (N)				
Reed switch	—	Grommet	Yes	3-wire (Equiv. NPN)	—	5 V	—	C76	●	●	—	—	—	IC	—
				2-wire	24 V	12 V	100 V	C73	●	●	●	—	—	—	Relay, PLC
		100 V, 200 V					B54	●	●	●	—	—			
		—					C73C	●	●	●	●	—	—		
		—					A33A	—	—	—	●	—	—		
	100 V, 200 V	A34A	—	—	—	●	—	—							
—	A44A	—	—	—	●	—	—	—							
Diagnostic indication (2-color)	Grommet	—	—	—	—	B59W	●	●	—	—	—	—	Relay, PLC		
Solid state switch	—	Grommet	Yes	3-wire (NPN)	24 V	5 V, 12 V	—	H7A1	●	●	○	—	○	IC	Relay, PLC
				3-wire (PNP)				H7A2	●	●	○	—	○		
		2-wire		H7B				●	●	○	—	○			
		3-wire (NPN)		H7C				●	●	●	●	—	—		
		2-wire		G39A				—	—	—	●	—	—		
	3-wire (NPN)	K39A		—	—	—	●	—	—	—					
	3-wire (PNP)	H7NW		●	●	○	—	○	IC						
	3-wire (PNP)	H7PW		●	●	○	—	○							
	2-wire	H7BW		●	●	○	—	○							
	Water resistant (2-color)	Grommet		—	2-wire	12 V	—	—	H7BA	—	●	○	—	○	
With diagnostic output (2-color)	3-wire (NPN)		5 V, 12 V		—	—	H7NF	●	●	○	—	○	IC		

* Lead wire length symbols: 0.5 m Nil (Example) C73C
 3 m L (Example) C73CL
 5 m Z (Example) C73CZ
 None N (Example) C73CN

* ○: Manufactured upon receipt of order.

* Do not add the suffix (N) indicating "no lead wire" to the part numbers of models D-A3□A, A44A, G39A and K39A.

In addition to the models in the above table, there are some other auto switches that are applicable. For more information, please consult with SMC.

- RE^A_B
- REC
- C□X
- C□Y
- MQ^Q_M
- RHC
- MK(2)
- RS^Q_G
- RS^H_A
- RZQ
- MI^W_S
- CEP1
- CE1
- CE2
- ML2B
- C¹_{5-S}
- CV
- MVGQ
- CC
- RB
- J
- D-
- X
- 20-
- Data

Series CM2Y



Integral clevis

Specifications

Bore size (mm)	20	25	32	40
Action	Double acting, Single rod			
Piston speed	5 to 500 mm/s			
Fluid	Air			
Proof pressure	1.05 MPa			
Maximum operating pressure	0.7 MPa			
Ambient and fluid temperature	Without auto switch -10 to 70°C (with no freezing) With auto switch -10 to 60°C (with no freezing)			
Lubrication	Non-lube			
Thread tolerance	JIS class 2			
Stroke length tolerance	$^{+1.4}_0$ mm			
Cushion	Rubber bumper			
Allowable leakage rate	0.5 ℓ/min (ANR) or less			

Minimum Operating Pressure

Unit: MPa				
Bore size (mm)	20	25	32	40
Minimum operating pressure	0.02			

JIS Symbol

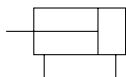

Mounting Bracket and Accessory

Mounting \ Accessory	Standard			Option		
	Mounting nut	Rod end nut	Clevis pin	Single knuckle joint	Note 3) Double knuckle joint	Note 4) Clevis bracket
Basic style	● (1 pc.)	●	—	●	●	—
Axial foot style	● (2)	●	—	●	●	—
Front flange style	● (1)	●	—	●	●	—
Rear flange style	● (1)	●	—	●	●	—
Integral clevis style	— Note1)	●	—	●	●	●
Single clevis style	— Note1)	●	—	●	●	—
Double clevis style Note 3)	— Note1)	●	●	●	●	—
Front trunnion style	● (1) Note2)	●	—	●	●	—
Rear trunnion style	● (1) Note2)	●	—	●	●	—
Boss-cut basic style	● (1)	●	—	●	●	—
Boss-cut flange style	● (1)	●	—	●	●	—
Boss-cut trunnion style	● (1)	●	—	●	●	—



Note 1) Mounting nuts are not attached to the integral clevis, single clevis and double clevis types.

Note 2) Trunnion nuts are mounted on the front trunnion style and rear trunnion style.

Note 3) Pins and snap rings (cotter pins in case of ø40) are packed with the double clevis and double knuckle joint styles.

Note 4) Pins and snap rings are packed with clevis brackets.

Grease Pack for Maintenance

When only grease for maintenance is necessary, please order by the following part numbers.

Grease pack GR-L-005 (5 g)
GR-L-010 (10 g)
GR-L-150 (150 g)

Standard Stroke

Bore size (mm)	Standard stroke (mm)
20, 25, 32, 40	25, 50, 75, 100, 125, 150, 200, 250, 300



Note 1) Intermediate strokes not listed above are also available.

Note 2) As the stroke increases, more sliding resistance may result due to the deflection of the piston rod and other factors. Take measures such as the installation of a guide.

Smooth Cylinder Series CM2Y

Dimensions/ø20 to ø40



Mounting bracket dimensions are the same as those of the standards, double acting, single rod type of Series CM2. Please refer to page of Best Pneumatics Vol. 6.

Basic style: CM2YB

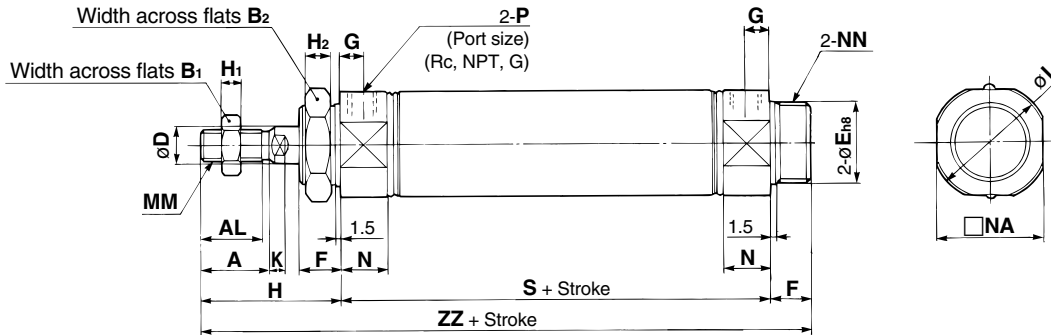

Boss-cut

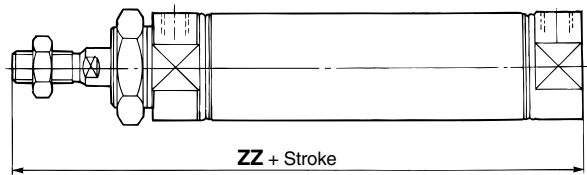

Bore size (mm)	A	AL	B ₁	B ₂	D	E	F	G	H	H ₁	H ₂	I	K	MM	N	NA	NN	P	S	ZZ
20	18	15.5	13	26	8	20 ⁰ _{-0.033}	13	8	41	5	8	28	5	M8 x 1.25	15	24	M20 x 1.5	1/8	62	116
25	22	19.5	17	32	10	26 ⁰ _{-0.033}	13	8	45	6	8	33.5	5.5	M10 x 1.25	15	30	M26 x 1.5	1/8	62	120
32	22	19.5	17	32	12	26 ⁰ _{-0.033}	13	8	45	6	8	37.5	5.5	M10 x 1.25	15	34.5	M26 x 1.5	1/8	64	122
40	24	21	22	41	14	32 ⁰ _{-0.039}	16	11	50	8	10	46.5	7	M14 x 1.5	21.5	42.5	M32 x 2	1/4	88	154

Bore size (mm)	ZZ
20	103
25	107
32	109
40	138

RE^A_B

REC

C□X

C□Y

MQ^Q_M

RHC

MK(2)

RS^Q_G

RS^H_A

RZQ

MI^W_S

CEP1

CE1

CE2

ML2B

C¹_G5-S

CV

MVGQ

CC

RB

J

D-

-X

20-

Data

Smooth Cylinder Series CG1Y

ø20, ø25, ø32, ø40, ø50, ø63, ø80, ø100



Specifications and auto switch information not provided below are the same as those of the low friction, double acting, single rod type of Series CG1□Q. Please refer to page of Best Pneumatics Vol. 6.

How to Order

Without auto switch

CG1Y L 25 □ 100

With auto switch

CDG1Y L 25 □ 100 H7BW S

Built-in magnet

Mounting style

Bore size

Number of auto switches

Nil	2 pcs.
S	1 pc.
n	n pcs.

B	Basic style
L	Axial foot style
F	Front flange style
G	Rear flange style
U*	Front trunnion style
T*	Rear trunnion style
D	Clevis style

20	20 mm
25	25 mm
32	32 mm
40	40 mm
50	50 mm
63	63 mm
80	80 mm
100	100 mm

Auto switch

Nil	Without auto switch (Built-in magnet)
-----	---------------------------------------

* For the applicable auto switch model, refer to the table below.

Cylinder stroke (mm)

Refer to "Standard Stroke" on page 10-4-13.

Thread type

Nil	Rc
TN	NPT
TF	G



* Not available at ø80 and ø100.
Note) Mounting brackets are not mounted and are supplied loose at the time of shipment.

Applicable Auto Switch/Refer to page 10-20-1 for further information on auto switches.

Type	Special function	Electrical entry	Indicator light	Wiring (Output)	Load voltage		Auto switch model		Lead wire (m)*				Pre-wire connector	Applicable load			
					DC	AC	Applicable bore size		0.5 (Nil)	3 (L)	5 (Z)	None (N)		IC	Relay, PLC		
							ø20 to ø63	ø20 to ø100									
Reed switch	-	Grommet	Yes	3-wire (Equiv. NPN)	-	5 V	-	C76	-	●	●	-	-	-	IC	-	
				2-wire	24 V	12 V	100 V, 200 V	B54	●	●	●	-	-	-	-	-	-
		100 V					C73	●	●	●	-	-	-	-	-	-	-
		Diagnostic indication (2-color)		Grommet	-	-	-	C73C	●	●	●	●	-	-	-	-	-
Solid state switch	-	Grommet	Yes	3-wire (NPN)	24 V	5 V, 12 V	-	H7A1	G59	●	●	○	-	○	IC	Relay, PLC	
				3-wire (PNP)				H7A2	G5P	●	●	○	-	○			
		2-wire		H7B	K59	●		●	○	-	○	-	-				
				H7C	-	●		●	●	●	-	-	-				
		Diagnostic indication (2-color)		Grommet	3-wire (NPN)	24 V		5 V, 12 V	H7NW	G59W	●	●	○	-	○		IC
					3-wire (PNP)				H7PW	G5PW	●	●	○	-	○		
		Water resistant (2-color)		Grommet	2-wire	24 V		12 V	H7BW	K59W	●	●	○	-	○		-
									H7BA	G5BA	-	●	○	-	○		-
		With diagnostic output (2-color)		Grommet	4-wire(NPN)	24 V		5 V, 12 V	H7NF	G59F	●	●	○	-	○		IC

* Lead wire length symbols: 0.5 m Nil (Example) C73C
 3 m L (Example) C73CL
 5 m Z (Example) C73CZ
 None N (Example) C73CN

* ○: Manufactured upon receipt of order.

In addition to the models in the above table, there are some other auto switches that are applicable. For more information, refer to page of Best Pneumatics Vol. 7.

Smooth Cylinder Series CG1Y



Specifications

Bore size (mm)	20	25	32	40	50	63	80	100
Action	Double acting, Single rod							
Type	Non-lube							
Fluid	Air							
Proof pressure	1.05 MPa							
Maximum operating pressure	0.7 MPa							
Ambient and fluid temperature	Without auto switch -10 to 70°C (with no freezing) With auto switch -10 to 60°C (with no freezing)							
Operating piston speed	5 to 500 mm/s							
Stroke length tolerance	Up to 300 ^{st+1.4} ₀ mm							
Cushion	Rubber bumper							
Mounting	Basic, Axial foot, Front flange, Rear flange, Front trunnion, Rear trunnion, Clevis (in case of 90° change in port location)							
Allowable leakage rate	0.5 ℓ/min (ANR) or less							



* Front trunnion and rear trunnion styles are not available at ø80 and ø100.

JIS Symbol

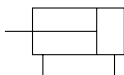

Replacement Parts: Seal Kit

Bore size (mm)	Kit no.	Contents
20	CG1Y20-PS	
25	CG1Y25-PS	
32	CG1Y32-PS	Piston seal 1 pc.
40	CG1Y40-PS	Rod seal 1 pc.
50	CG1Y50-PS	Tube gasket 2 pcs.
63	CG1Y63-PS	Grease pack (10 g) 1 pc.
80	CG1Y80-PS	
100	CG1Y100-PS	

When only grease for maintenance is necessary, please order by the following part numbers.

Grease pack GR-L-005 (5 g)
GR-L-010 (10 g)
GR-L-150 (150 g)

Minimum Operating Pressure

Bore size (mm)	Unit: MPa							
	20	25	32	40	50	63	80	100
Minimum operating pressure	0.02				0.01			

Standard Stroke

Bore size (mm)	Standard stroke (mm) <small>Note 1)</small>
20	25, 50, 75, 100, 125, 150, 200
25, 32, 40, 50, 63, 80, 100	25, 50, 75, 100, 125, 150, 200, 250, 300



Note 1) Intermediate strokes not listed above are also available.

Note 2) Please consult with SMC for strokes outside the above ranges.

Note 3) As the stroke increases, more sliding resistance may result due to the deflection of the piston rod and other factors. Take measures such as the installation of a

RE_B^A

REC

C□X

C□Y

MQ_M^Q

RHC

MK(2)

RS_G^QRS_A^H

RZQ

MI_S^W

CEP1

CE1

CE2

ML2B

C₆¹5-S

CV

MVGQ

CC

RB

J

D-

-X

20-

Data

Series CG1Y

Dimensions: $\varnothing 20$ to $\varnothing 100$



Mounting bracket dimensions are the same as those of the **low friction, double acting, single rod type of Series CG1□Q**. Please refer to page of Best Pneumatics Vol. 6.

Basic style: CG1YB

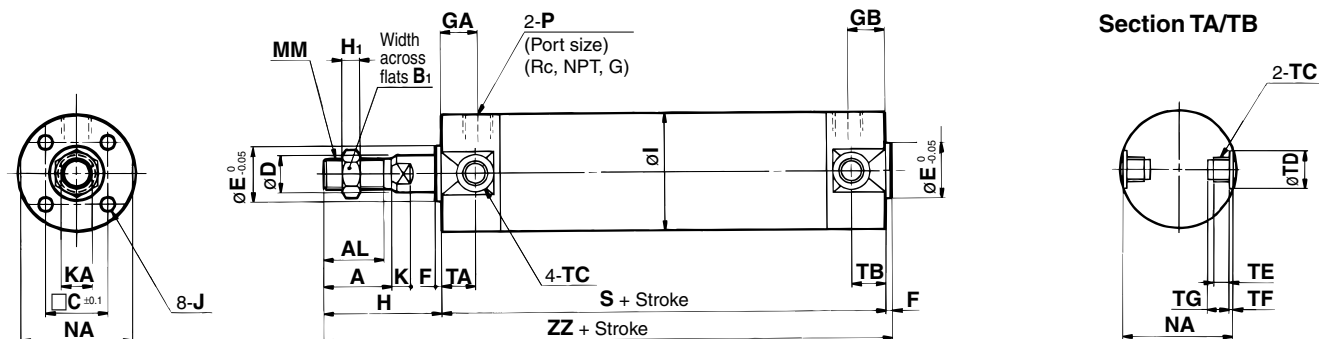

Section TA/TB

(mm)

Bore size (mm)	TC*	TDH9	TE	TF	TG
20	M5 x 0.8	8 ^{+0.08} ₀	4	0.5	5.5
25	M6 x 0.75	10 ^{+0.08} ₀	5	1	6.5
32	M8 x 1.0	12 ^{+0.08} ₀	5.5	1	7.5
40	M10 x 1.25	14 ^{+0.08} ₀	6	1.25	8.5
50	M12 x 1.25	16 ^{+0.08} ₀	7.5	2	10
63	M14 x 1.5	18 ^{+0.08} ₀	11.5	3	14.5

* Trunnion mounting taps for the width across flats NA are not attached to $\varnothing 80$ and $\varnothing 100$ types.

(mm)

Bore size (mm)	Stroke range (mm)	A	AL	B1	C	D	E	F	GA	GB	H	H1	I	J	K	KA	MM
20	Up to 200	18	15.5	13	14	8	12	2	12	12	35	5	26	M4 x 0.7 depth 7	5	6	M8 x 1.25
25	Up to 300	22	19.5	17	16.5	10	14	2	12	12	40	6	31	M5 x 0.8 depth 7.5	5.5	8	M10 x 1.25
32	Up to 300	22	19.5	17	20	12	18	2	12	12	40	6	38	M5 x 0.8 depth 8	5.5	10	M10 x 1.25
40	Up to 300	30	27	19	26	16	25	2	13	13	50	8	47	M6 x 1 depth 12	6	14	M14 x 1.5
50	Up to 300	35	32	27	32	20	30	2	14	14	58	11	58	M8 x 1.25 depth 16	7	18	M18 x 1.5
63	Up to 300	35	32	27	38	20	32	2	14	14	58	11	72	M10 x 1.5 depth 16	7	18	M18 x 1.5
80	Up to 300	40	37	32	50	25	40	3	20	20	71	13	89	M10 x 1.5 depth 22	10	22	M22 x 1.5
100	Up to 300	40	37	41	60	30	50	3	20	20	71	16	110	M12 x 1.75 depth 22	10	26	M26 x 1.5

(mm)

Bore size (mm)	Stroke range (mm)	NA	P	S	TA	TB	ZZ
20	Up to 200	24	1/8	77	11	11	114
25	Up to 300	29	1/8	77	11	11	119
32	Up to 300	35.5	1/8	79	11	11	121
40	Up to 300	44	1/8	87	12	12	139
50	Up to 300	55	1/4	102	13	13	162
63	Up to 300	69	1/4	102	13	13	162
80	Up to 300	80	3/8	122	–	–	196
100	Up to 300	100	1/2	122	–	–	196

Smooth Cylinder Series CA2Y

ø40, ø50, ø63, ø80, ø100



Specifications and auto switch information not provided below are the same as those of the **standard, double acting, single rod type of Series CA2**. Please refer to page of Best Pneumatics Vol. 6.

How to Order

Without auto switch

CA2Y L 40 [] 150

With auto switch

CDA2Y L 40 [] 150 Y7BW S

Built-in magnet

Mounting style

B	Basic style
L	Axial foot style
F	Front flange style
G	Rear flange style
C	Single clevis style
D	Double clevis style
T	Center trunnion style

Bore size

40	40 mm
50	50 mm
63	63 mm
80	80 mm
100	100 mm

Built-in Magnet Cylinder Model

If built-in magnet type is ordered without auto switch, leave the field for the auto switch type blank. (Example) CDA2YB40-100

Number of auto switches

Nil	2 pcs.
S	1 pc.
3	3 pcs.
n	n pcs.

Auto switch

Nil	Without auto switch
-----	---------------------

* For the applicable auto switch model, refer to the table below.
* Models D-Z7□, Z80, Y59□, Y69, and Y7□ are not mounted and are supplied loose at the time of shipment. (Only switch mounting brackets for above models are mounted.)

Cylinder stroke (mm)

Refer to "Standard Stroke" on page 10-4-16.

Thread type

Nil	Rc
TN	NPT
TF	G

Applicable Auto Switch/Refer to page 10-20-1 for further information on auto switches.

Type	Special function	Electrical entry	Indicator light	Wiring (Output)	Load voltage		Auto switch model	Lead wire (m)*			Pre-wire connector	Applicable load		
					DC	AC		0.5 (Nil)	3 (L)	5 (Z)				
Reed switch	-	Grommet	Yes	3-wire (NPN)	-	5 V	-	Z76	●	●	-	-	IC	-
				2-wire	24 V	12 V	100 V	Z73	●	●	●	-	-	Relay, PLC
	Diagnostic indication (2-color)	Grommet	-	-	-	A54	●	●	●	-	-			
Solid state switch	-	Grommet	Yes	3-wire (NPN)	24 V	5 V, 12 V	-	Y59A	●	●	○	○	IC	Relay, PLC
				3-wire (PNP)	-	-	100 V, 200 V	Y7P	●	●	○	○		
				2-wire	-	-	100 V, 200 V	Y51	●	●	○	○		
	Diagnostic indication (2-color)	Grommet	Yes	3-wire (NPN)	24 V	5 V, 12 V	-	Y59B	●	●	○	○	-	
				Y7NW				●	●	○	○	IC		
				Y7PW				●	●	○	○	-		
	Water resistant (2-color)	Grommet	Yes	2-wire	24 V	12 V	-	Y7BW	●	●	○	○	-	
				Y7BA				-	●	○	○	-		
				F59F				●	●	○	○	IC		
Magnetic field resistant (2-color)	Grommet	Yes	4-wire (NPN)	24 V	5 V, 12 V	-	P5DW	-	●	●	○	-		
			2-wire				-	-	-	-	○	-		

* Lead wire length symbols: 0.5 m Nil (Example) A54
3 m L (Example) A54L
5 m Z (Example) A54Z

* ○: Manufactured upon receipt of order.

In addition to the models in the above table, there are some other auto switches that are applicable. For more information, refer to page of Best Pneumatics Vol. 6.

- RE^A_B
- REC
- C□X
- C□Y
- MQ^Q_M
- RHC
- MK(2)
- RS^Q_G
- RS^H_A
- RZQ
- MI^W_S
- CEP1
- CE1
- CE2
- ML2B
- C_G5-S
- CV
- MVGQ
- CC
- RB
- J
- D-
- X
- 20-
- Data

Series CA2Y

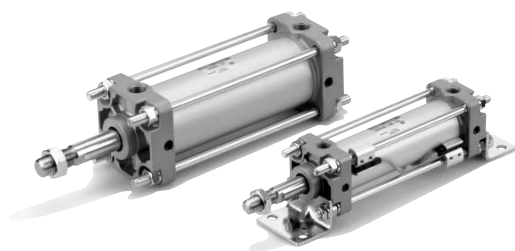

JIS Symbol

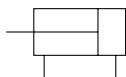

Replacement Parts: Seal Kit

Bore size (mm)	Kit no.	Contents
40	CA2Y40-PS	Rod seal 1 pc.
50	CA2Y50-PS	Piston seal 1 pc.
63	CA2Y63-PS	Cylinder tube gasket 2 pcs.
80	CA2Y80-PS	Grease pack (10 g) 1 pc.
100	CA2Y100-PS	

When only grease for maintenance is necessary, please order by the following part numbers.

Grease pack GR-L-005 (5 g)
GR-L-010 (10 g)

Specifications

Action	Double acting
Operating piston speed	5 to 500 mm/s
Fluid	Air
Proof pressure	1.05 MPa
Maximum operating pressure	0.7 MPa
Ambient and fluid temperature	Without auto switch -10 to 70°C (with no freezing) With auto switch -10 to 60°C (with no freezing)
Cushion	None
Thread tolerance	JIS class 2
Lubrication	Not required (Non-lube)
Mounting	Basic, Axial foot, Front flange, Rear flange, Single clevis, Double clevis Center trunnion
Allowable leakage rate	0.5 ℓ/min (ANR)

Minimum Operating Pressure

Unit: MPa					
Bore size (mm)	40	50	63	80	100
Minimum operating pressure	0.02			0.01	

Standard Stroke

Bore size (mm)	Standard stroke (mm)
40	25, 50, 75, 100, 125, 150, 175, 200, 250, 300, 350, 400, 450, 500
50, 63	25, 50, 75, 100, 125, 150, 175, 200, 250, 300, 350, 400, 450, 500, 600
80, 100	25, 50, 75, 100, 125, 150, 175, 200, 250, 300, 350, 400, 450, 500, 600, 700



Note 1) Intermediate strokes not listed above are also available.

Please consult with SMC for strokes outside the above ranges.

Note 2) As the stroke increases, more sliding resistance may result due to the deflection of the piston rod and other factors. Take measures such as the installation of a guide.

Accessory

Mounting		Basic	Foot	Front flange	Rear flange	Single clevis	Double clevis	Center trunnion
Standard	Jam nut	●	●	●	●	●	●	●
	Clevis pin	—	—	—	—	—	●	—
Option	Single knuckle joint	●	●	●	●	●	●	●
	Double knuckle joint (with pin)	●	●	●	●	●	●	●

Smooth Cylinder Series CA2Y

Dimensions: $\varnothing 40$ to $\varnothing 100$



Mounting bracket dimensions are the same as those of the **low friction, double acting, single rod type of Series CA2**. Please refer to page of Best Pneumatics Vol. 6.

Basic style: CA2YB

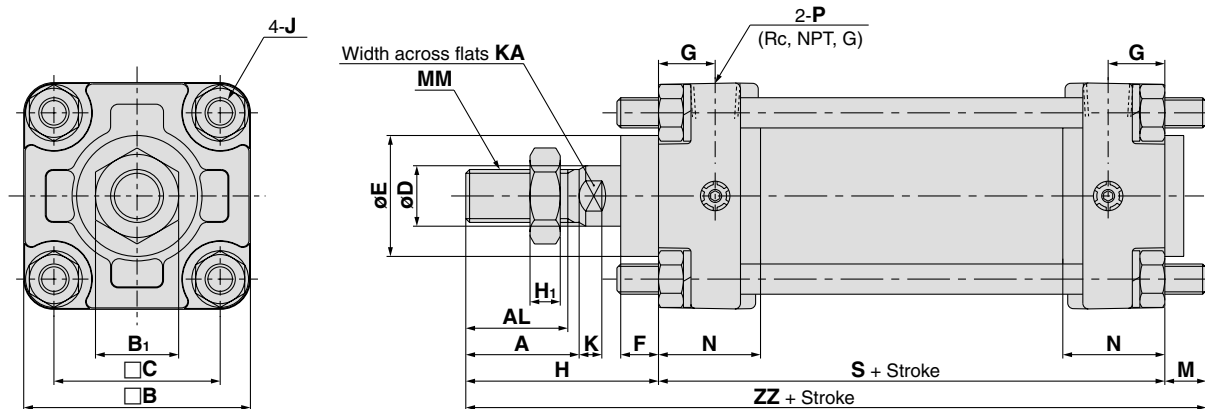

(mm)

Bore size (mm)	Stroke range	A	AL	$\square B$	B ₁	$\square C$	D	E	F	G	H	H ₁	J	K	KA	M	MM	N	P	S	ZZ
40	Up to 500	30	27	60	22	44	16	32	10	15	51	8	M8 x 1.25	6	14	11	M14 x 1.5	27	1/4	84	146
50	Up to 600	35	32	70	27	52	20	40	10	17	58	11	M8 x 1.25	7	18	11	M18 x 1.5	30	3/8	90	159
63	Up to 600	35	32	85	27	64	20	40	10	17	58	11	M10 x 1.25	7	18	14	M18 x 1.5	31	3/8	98	170
80	Up to 700	40	37	102	32	78	25	52	14	21	71	13	M12 x 1.75	10	22	17	M22 x 1.5	37	1/2	116	204
100	Up to 700	40	37	116	41	92	30	52	14	21	72	16	M12 x 1.75	10	26	17	M26 x 1.5	40	1/2	126	215

- RE^A_B
- REC
- C□X
- C□Y
- MQ^Q_M
- RHC
- MK(2)
- RS^Q_G
- RS^H_A
- RZQ
- MI^W_S
- CEP1
- CE1
- CE2
- ML2B
- C¹_G5-S
- CV
- MVGQ
- CC
- RB
- J
- D-
- X
- 20-
- Data