



# ISO Standards [ISO/21287] Compact Cylinder



*Series C55*

# ISO Standards [ISO/21287] Compact Cylinder

## Series C55

Ø20, Ø25, Ø32, Ø40, Ø50, Ø63

### How to Order

**Without auto switch**

**With auto switch**

C55 **B** **20** — **10** □

CD55 **B** **20** — **10** □ — **M9B** **S**

• Number of auto switches

Nil	2 pcs.
S	1 pc.
n	"n" pcs.

• Built in magnet

• Mounting style

<b>B</b>	Through-hole/Both ends tapped common (Standard)
<b>L</b>	Foot style
<b>F</b>	Rod side flange style
<b>G</b>	Head side flange style
<b>C</b>	Single clevis style

• Bore size

<b>20</b>	20 mm
<b>25</b>	25 mm
<b>32</b>	32 mm
<b>40</b>	40 mm
<b>50</b>	50 mm
<b>63</b>	63 mm

• Auto switch

<b>Nil</b>	Without auto switch (Built-in magnet cylinder)
------------	--

\* For the applicable auto switch model, refer to the table below.  
\* Auto switches are shipped together, (but not assembled).

• Rod end thread

<b>Nil</b>	Rod end female thread
<b>M</b>	Rod end male thread

• Cylinder stroke (mm)

Refer to the next page for standard and intermediate strokes.

### Applicable Auto Switches/Refer to pages 12 to 17 for further information on auto switches.

Type	Special function	Electrical entry	Indicator light	Wiring (Output)	Load voltage			Auto switch model		Lead wire length (m)*			Pre-wired connector	Applicable load		
					DC	AC	Electrical entry direction		0.5 (Nil)	3 (L)	5 (Z)	IC circuit		—		
							Perpendicular	In-line								
Reed switch	—	Grommet	Yes	3-wire (NPN equivalent)	—	5 V	—	<b>A96V</b>	<b>A96</b>	●	●	—	—	IC circuit	—	
				2-wire	24 V	12 V	100 V	<b>A93V</b>	<b>A93</b>	●	●	—	—	—	Relay, PLC	
					5 V, 12 V	100 V or less	<b>A90V</b>	<b>A90</b>	●	●	—	—	—	IC circuit		
Solid state switch	—	Grommet	Yes	3-wire (NPN)	24 V	5 V	—	<b>M9NV</b>	<b>M9N</b>	●	●	○	○	IC circuit	Relay, PLC	
				3-wire (PNP)		12 V		<b>M9PV</b>	<b>M9P</b>	●	●	○	○	—		
				2-wire		12 V		<b>M9BV</b>	<b>M9B</b>	●	●	○	○	—		
				3-wire (NPN)		5 V		<b>F9NWV</b>	<b>F9NW</b>	●	●	○	○	IC circuit		
				3-wire (PNP)		12 V		<b>F9PWV</b>	<b>F9PW</b>	●	●	○	○	—		
				Water resistant (2-color indication)		2-wire		12 V	<b>F9BWV</b>	<b>F9BW</b>	●	●	○	○		—
								—	<b>F9BA</b>	—	●	○	—	—		

\* Lead wire length symbols: 0.5 m ..... Nil (Example) M9N  
3 m ..... L (Example) M9NL  
5 m ..... Z (Example) M9NZ

\* ○ solid state auto switch is available after receiving an order.

## Specifications



### ⚠ Caution

- ① Be sure to read before handling. Refer to Best Pneumatics catalog Vol. 6/7/8/9/10 for Safety Instructions, Actuators and Auto Switches Precautions.
- ② This product should not be used as a stopper.
- ③ Use the PF thread fittings for this cylinder

### Theoretical Output



Unit: N

Bore size (mm)	Operating direction	Operating pressure (MPa)		
		0.3	0.5	0.7
20	IN	71	118	165
	OUT	94	157	220
25	IN	113	189	264
	OUT	147	245	344
32	IN	181	302	422
	OUT	241	402	563
40	IN	317	528	739
	OUT	377	628	880
50	IN	495	825	1150
	OUT	589	982	1370
63	IN	841	1400	1960
	OUT	935	1560	2180

### Mounting Bracket Part No.

Bore size (mm)	Foot	Flange	Single clevis
20	C55-L020	C55-F020	C55-C020
25	C55-L025	C55-F025	C55-C025
32	C55-L032	C55-F032	C55-C032
40	C55-L040	C55-F040	C55-C040
50	C55-L050	C55-F050	C55-C050
63	C55-L063	C55-F063	C55-C063

- Order two foot brackets per cylinder.
- Parts belonging to each bracket are as follows. Foot, Flange, Single clevis/Body mounting bolt

Type	Pneumatic (Non-lube)
Action	Double acting, Single rod
Fluid	Air
Proof pressure	1.5 MPa
Maximum operating pressure	1.0 MPa
Minimum operating pressure	0.05 MPa
Ambient and fluid temperature	Without auto switch: -10 to 70°C (No freezing) With auto switch: -10 to 60°C (No freezing)
Cushion	Rubber bumper on both end
Stroke length tolerance	+1.0 mm 0
Mounting	Through-hole/Both ends tapped common
Piston speed	50 to 500 mm/s

## Standard Stroke

Bore size (mm)	Standard stroke (mm)
20 to 63	5, 10, 15, 20, 25, 30, 35, 40, 45, 50, 60, 80, 100, 125, 150

## Manufacture of Intermediate Stroke

Description	Dealing with the stroke by the 1 mm interval by using an exclusive body with the specified stroke
Part no.	Refer to "How to Order" for the standard model no. (page at left)
Stroke range	6 to 149
Example	Part no.: C55B32-47
	Makes 47 stroke tube

## Weight

### Without Auto Switch

Unit: g

Bore size (mm)	Cylinder stroke (mm)														
	5	10	15	20	25	30	35	40	45	50	60	80	100	125	150
20	111	124	137	150	163	176	189	202	215	228	254	306	357	422	487
25	152	168	183	199	214	230	246	261	277	292	323	386	448	526	603
32	250	273	295	317	339	362	384	406	428	451	495	584	673	785	896
40	315	339	364	388	412	436	461	485	509	533	582	679	776	897	1018
50	497	534	570	607	644	681	718	755	791	828	902	1049	1197	1381	1565
63	677	717	757	797	837	877	917	957	997	1037	1117	1277	1437	1638	1838

### With Auto Switch (Built-in magnet)

Unit: g

Bore size (mm)	Cylinder stroke (mm)														
	5	10	15	20	25	30	35	40	45	50	60	80	100	125	150
20	113	126	139	152	165	178	191	204	216	229	255	307	359	424	489
25	154	170	185	201	217	232	248	263	279	294	325	388	450	528	606
32	254	277	299	321	343	366	388	410	432	455	499	588	677	788	900
40	319	344	368	392	416	441	465	489	513	537	586	683	780	901	1022
50	502	539	575	612	649	686	723	760	796	833	907	1054	1202	1386	1570
63	685	725	765	805	845	885	925	965	1005	1045	1125	1285	1445	1645	1845

Add each weight of auto switches and mounting brackets when mounting an auto switches. Refer to pages 14 to 17 for auto switch weight.

# Series C55

## Allowable Lateral Load

Make sure to operate strictly within the allowable lateral load range to the rod end.

Operation outside of this range may result in shorter service life or damage to the device.

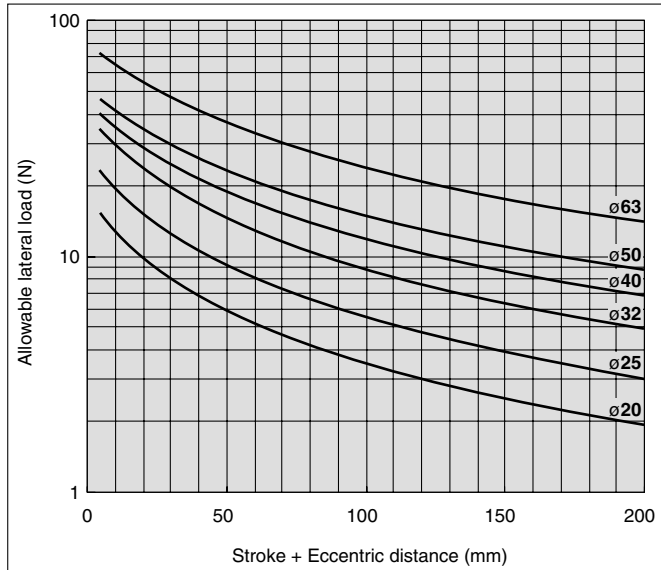
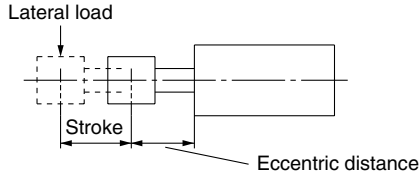

## Allowable Kinetic Energy

Make sure to operate strictly within the allowable range of the load weight and maximum speed.

Operation outside of this range may cause excessive impact, which may result in the damage to the device.

Operating pressure: 1 MPa

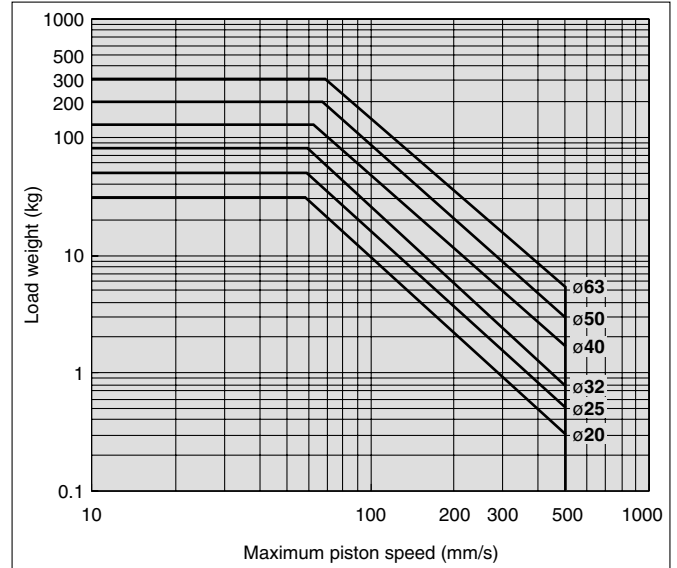

\* Refer to Model Selection in Best Pneumatics catalog Vol. 6/7 for details about model selection procedure.

## Construction

ø20, ø25

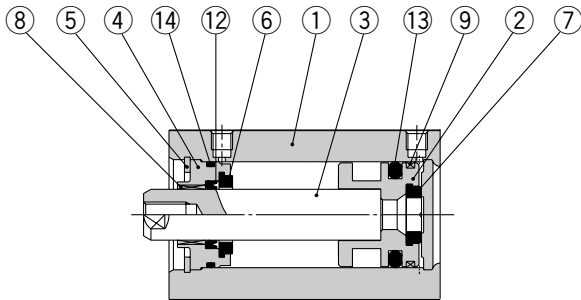

With auto switch (Built-in magnet)

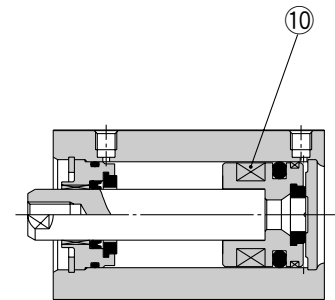

ø32 to ø63

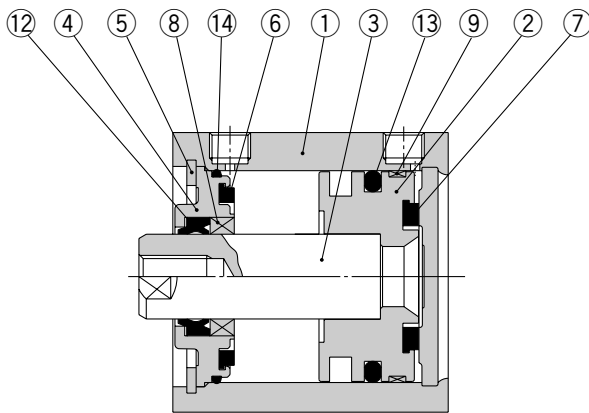

With auto switch (Built-in magnet)

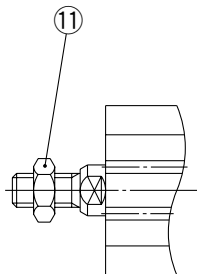
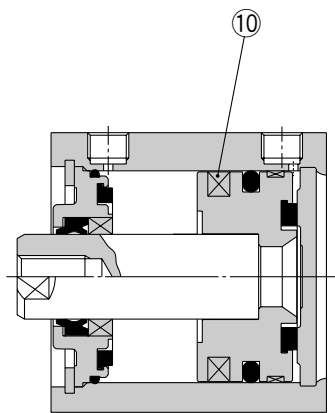

M: Rod end male thread

### Component Parts

No.	Description	Material	Note
1	Cylinder tube	Aluminum alloy	Hard anodized
2	Piston	Aluminum alloy	Chromated
3	Piston rod	Stainless steel	ø20, ø25
		Carbon steel	ø32 to ø63 Hard chrome plated
4	Collar	Aluminum alloy	ø20 to ø40 Anodized
		Aluminum alloy casted	ø50, ø63 Painted after chromated
5	Snap ring	Carbon tool steel	Phosphate coated
6	Bumper A	Urethane	
7	Bumper B	Urethane	
8	Bushing	Oil-impregnated sintered alloy	ø20, ø25
		Phosphor bronze alloy	ø32 to ø63
9	Wear ring	Resin	
10	Magnet	—	
11	Rod end nut	Carbon steel	Nickel plated
12	Rod seal	NBR	
13	Piston seal	NBR	
14	Tube gasket	NBR	

### Replacement Parts: Seal Kit

Bore size (mm)	Kit no.	Contents
20	CQ2B20-PS	Set of nos. above (12, 13, 14)
25	CQ2B25-PS	
32	CQ2B32-PS	
40	CQ2B40-PS	
50	CQ2B50-PS	
63	CQ2B63-PS	

\* Seal kit includes (12), (13), (14). Order the seal kit, based on each bore size.

# Series C55

## Mounting Bolt

Should use recommended bolt shown as below table when mounting the cylinder using through-hole.

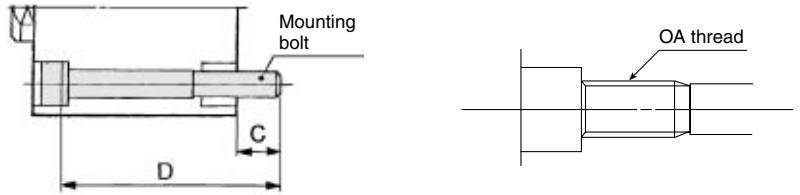

Note) To install a through-hole type mounting bolt, bore size 20 to 63 mm, make sure to use the flat washer that is provided.

## Mounting Bolt for C55

Model	C	D	Mounting bolt	
<b>C(D)55B20-5</b>	7.2	45	M4 x 45 ℓ	
<b>-10</b>		50	x 50 ℓ	
<b>-15</b>		55	x 55 ℓ	
<b>-20</b>		60	x 60 ℓ	
<b>-25</b>		65	x 65 ℓ	
<b>-30</b>		70	x 70 ℓ	
<b>-35</b>		75	x 75 ℓ	
<b>-40</b>		80	x 80 ℓ	
<b>-45</b>		85	x 85 ℓ	
<b>-50</b>		90	x 90 ℓ	
<b>-60</b>		Fix the cylinder by using the OA thread that are provided with the cylinder tube.		
<b>-80</b>				
<b>-100</b>				
<b>-125</b>				
<b>-150</b>				
<b>C(D)55B25-5</b>	10.2	50	M4 x 50 ℓ	
<b>-10</b>		55	x 55 ℓ	
<b>-15</b>		60	x 60 ℓ	
<b>-20</b>		65	x 65 ℓ	
<b>-25</b>		70	x 70 ℓ	
<b>-30</b>		75	x 75 ℓ	
<b>-35</b>		80	x 80 ℓ	
<b>-40</b>		85	x 85 ℓ	
<b>-45</b>		90	x 90 ℓ	
<b>-50</b>		95	x 95 ℓ	
<b>-60</b>		Fix the cylinder by using the OA thread that are provided with the cylinder tube.		
<b>-80</b>				
<b>-100</b>				
<b>-125</b>				
<b>-150</b>				

Model	C	D	Mounting bolt
<b>C(D)55B32-5</b>	10	55	M5 x 55 ℓ
<b>-10</b>		60	x 60 ℓ
<b>-15</b>		65	x 65 ℓ
<b>-20</b>		70	x 70 ℓ
<b>-25</b>		75	x 75 ℓ
<b>-30</b>		80	x 80 ℓ
<b>-35</b>		85	x 85 ℓ
<b>-40</b>		90	x 90 ℓ
<b>-45</b>		95	x 95 ℓ
<b>-50</b>		100	x 100 ℓ
<b>-60</b>		110	x 110 ℓ
<b>-80</b>		130	x 130 ℓ
<b>-100</b>	150	x 150 ℓ	
<b>-125</b>	Fix the cylinder by using the OA thread that are provided with the cylinder tube.		
<b>-150</b>			
<b>C(D)55B40-5</b>	9	55	M5 x 55 ℓ
<b>-10</b>		60	x 60 ℓ
<b>-15</b>		65	x 65 ℓ
<b>-20</b>		70	x 70 ℓ
<b>-25</b>		75	x 75 ℓ
<b>-30</b>		80	x 80 ℓ
<b>-35</b>		85	x 85 ℓ
<b>-40</b>		90	x 90 ℓ
<b>-45</b>		95	x 95 ℓ
<b>-50</b>		100	x 100 ℓ
<b>-60</b>		110	x 110 ℓ
<b>-80</b>		130	x 130 ℓ
<b>-100</b>	150	x 150 ℓ	
<b>-125</b>	Fix the cylinder by using the OA thread that are provided with the cylinder tube.		
<b>-150</b>			

Model	C	D	Mounting bolt
<b>C(D)55B50-5</b>	8.4	55	M6 x 55 ℓ
<b>-10</b>		60	x 60 ℓ
<b>-15</b>		65	x 65 ℓ
<b>-20</b>		70	x 70 ℓ
<b>-25</b>		75	x 75 ℓ
<b>-30</b>		80	x 80 ℓ
<b>-35</b>		85	x 85 ℓ
<b>-40</b>		90	x 90 ℓ
<b>-45</b>		95	x 95 ℓ
<b>-50</b>		100	x 100 ℓ
<b>-60</b>		110	x 110 ℓ
<b>-80</b>		130	x 130 ℓ
<b>-100</b>	150	x 150 ℓ	
<b>-125</b>	Fix the cylinder by using the OA thread that are provided with the cylinder tube.		
<b>-150</b>			
<b>C(D)55B63-5</b>	9.4	60	M6 x 60 ℓ
<b>-10</b>		65	x 65 ℓ
<b>-15</b>		70	x 70 ℓ
<b>-20</b>		75	x 75 ℓ
<b>-25</b>		80	x 80 ℓ
<b>-30</b>		85	x 85 ℓ
<b>-35</b>		90	x 90 ℓ
<b>-40</b>		95	x 95 ℓ
<b>-45</b>		100	x 100 ℓ
<b>-50</b>		105	x 105 ℓ
<b>-60</b>		115	x 115 ℓ
<b>-80</b>		135	x 135 ℓ
<b>-100</b>	155	x 155 ℓ	
<b>-125</b>	Fix the cylinder by using the OA thread that are provided with the cylinder tube.		
<b>-150</b>			

**Dimensions**

**ø20, ø25**

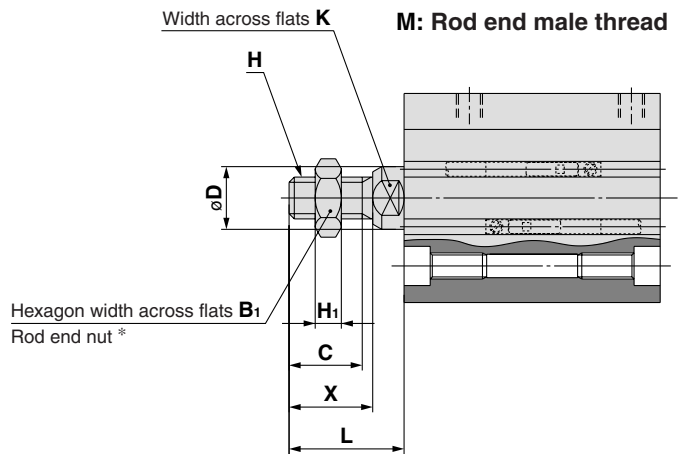
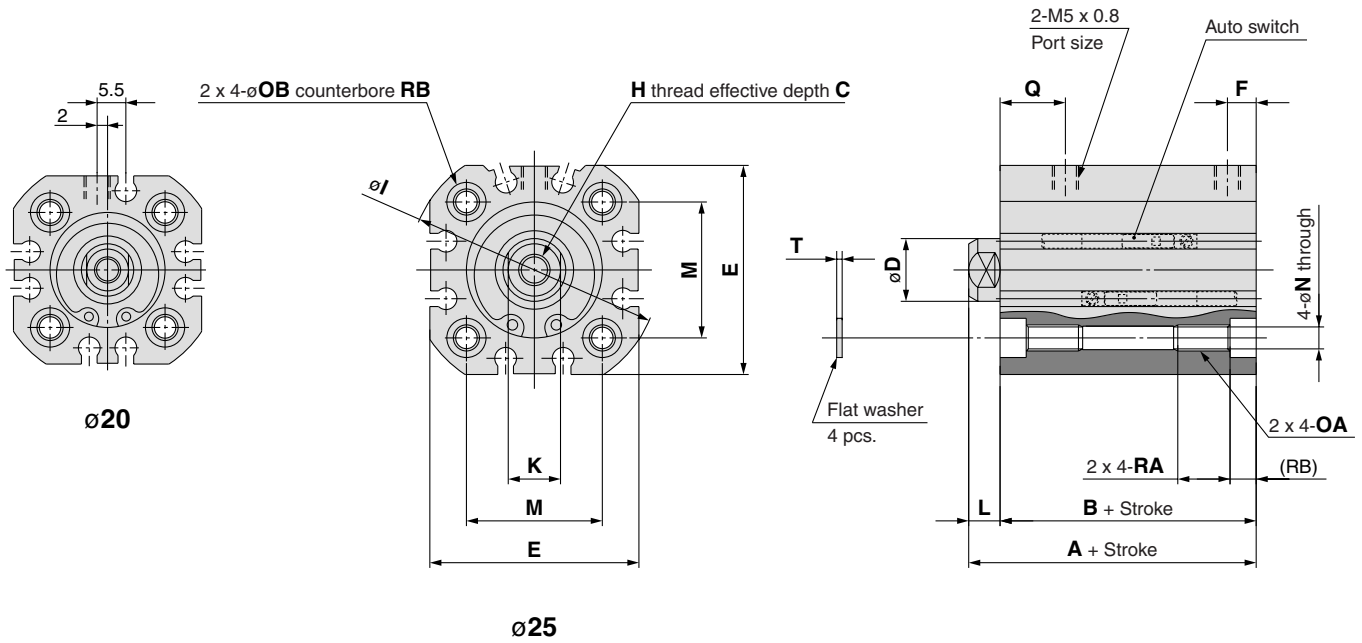

**Rod End Male Thread**

(mm)

Bore size (mm)	B <sub>1</sub>	C	D	H	H <sub>1</sub>	K	L	X
20	13	14	10	M8 x 1.25	5	8	22	16
25	13	14	12	M8 x 1.25	5	10	22	16

**Basic Style**

(mm)

Bore size (mm)	A	B	C	D	E	F	H	I	K	L	M	N	OA	OB	Q	RA	RB	T
20	43	37	10	10	36	5.5	M6 x 1.0	43	8	6	22	4.5	M5 x 0.8	7.5	13	10	5	0.8
25	45	39	10	12	40	5.5	M6 x 1.0	48	10	6	26	4.5	M5 x 0.8	7.5	13	10	5	0.8

# Series C55

## Dimensions

ø32 to ø63

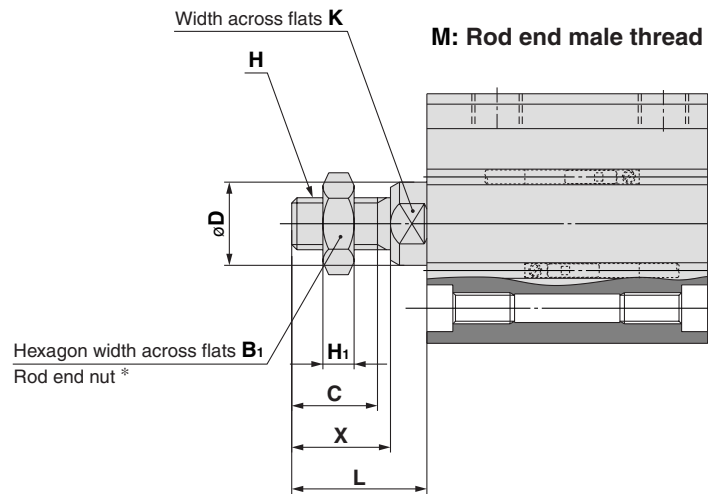
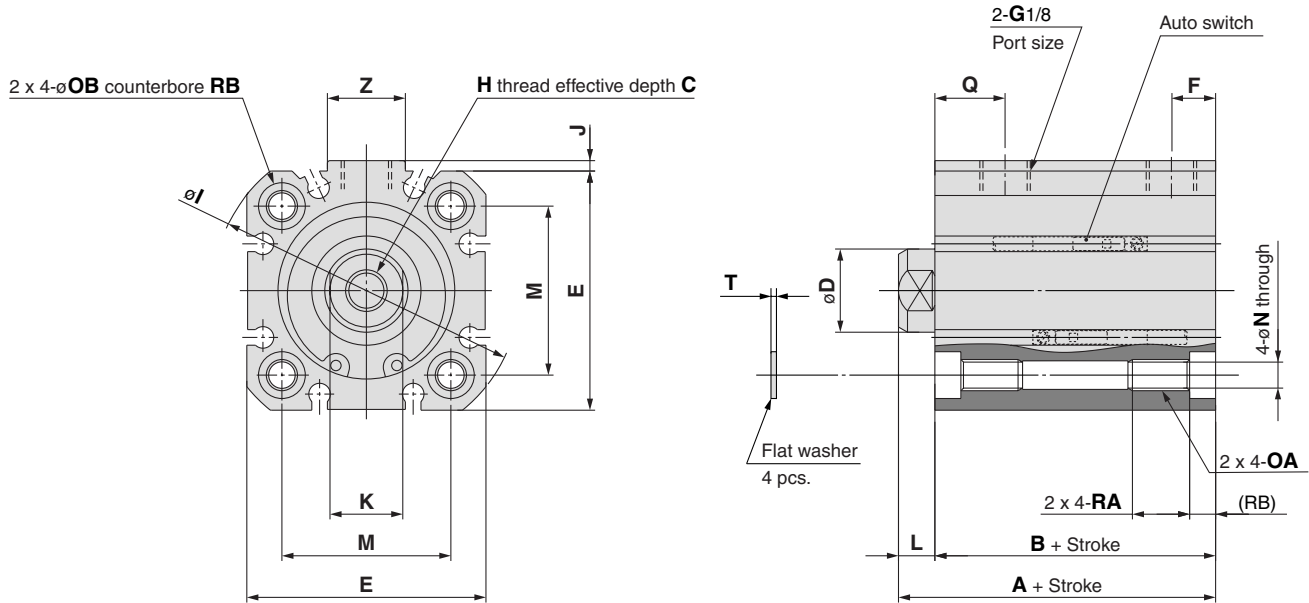

**Rod End Male Thread** (mm)

Bore size (mm)	B <sub>1</sub>	C	D	H	H <sub>1</sub>	K	L	X
32	17	16.5	16	M10 x 1.25	6	14	26	19
40	17	16.5	16	M10 x 1.25	6	14	26	19
50	19	19.5	20	M12 x 1.25	7	17	30	22
63	19	19.5	20	M12 x 1.25	7	17	30	22

**Basic Style**

(mm)

Bore size (mm)	A	B	C	D	E	F	H	I	J	K	L	M	N	OA	OB	Q	RA	RB	T	Z
32	51	44	12	16	46	8.5	M8 x 1.25	59	2	14	7	32.5	5.5	M6 x 1.0	9	14.5	11	5	1	15
40	52	45	12	16	52	9.5	M8 x 1.25	67	3	14	7	38	5.5	M6 x 1.0	9	14.5	11	5	1	17
50	53	45	16	20	64	10.5	M10 x 1.5	82	2	17	8	46.5	6.6	M8 x 1.25	10.5	13.5	11	5	1.6	17
63	57	49	16	20	74	14.5	M10 x 1.5	96	3	17	8	56.5	6.6	M8 x 1.25	10.5	15.5	11	5	1.6	17



## Mounting Bracket

### Foot bracket

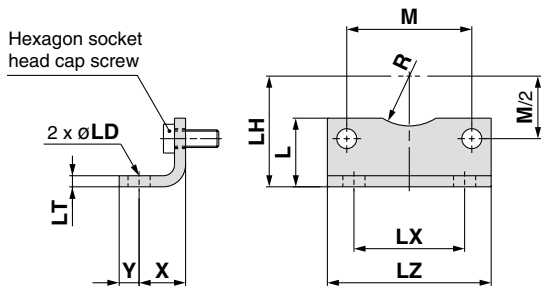

### Flange bracket

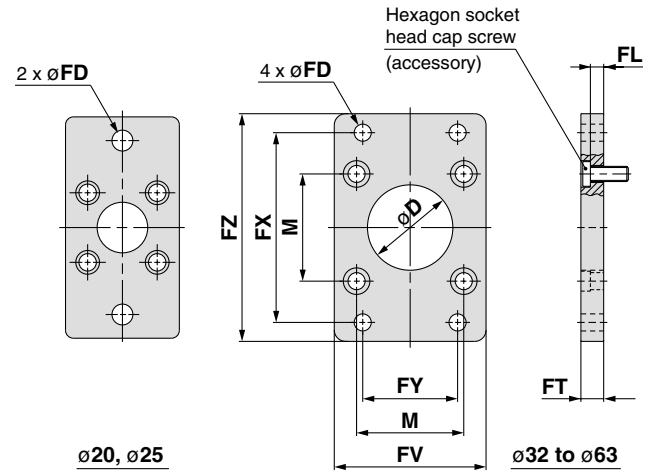

(mm)

Bore size (mm)	L	LD	LH	LT	LX	LZ	M	R	X	Y	Hexagon socket head cap screw
20	22	7	27	4	22	36	22	8	16	7	M5
25	22	7	29	4	26	40	26	10	16	7	M5
32	24.5	7	33.5	4	32	46	32.5	15	16	7	M6
40	26	10	38	4	36	52	38	17.5	18	9	M6
50	31	10	45	5	45	64	46.5	20	21	9	M8
63	31	10	50	5	50	74	56.5	22.5	21	9	M8

(mm)

Bore size (mm)	D <sub>H11</sub>	M	FD	FL	FT	FV	FX	FY	FZ	Hexagon socket head cap screw
20	16	22	6.6	2.8	8	38	55	—	68	M5
25	16	26	6.6	2.8	8	38	60	—	73	M5
32	30	32.5	7	5	10	50	64	32	79	M6
40	35	38	9	5	10	55	72	36	90	M6
50	40	46.5	9	6	12	70	90	45	110	M8
63	45	56.5	9	6	12	80	100	50	120	M8

### Single clevis bracket

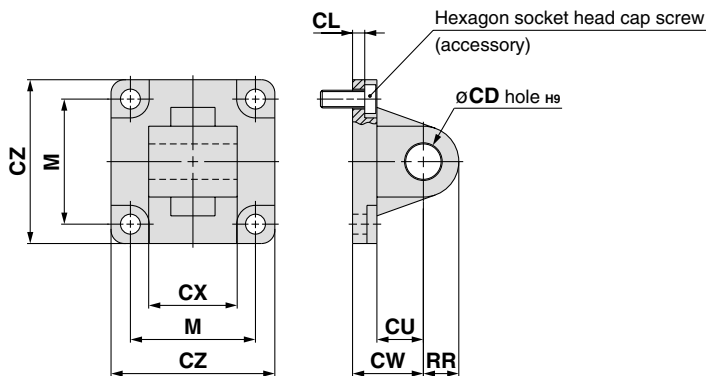

(mm)

Bore size (mm)	CD <sub>H9</sub>	CL	CU	CW	CX <sub>0.2-0.6</sub>	CZ	M	RR	Hexagon socket head cap screw
20	8	3	12	20	16	35	22	9	M5
25	8	3	12	20	16	40	26	9	M5
32	10	5.5	12	22	26	45	32.5	9.5	M6
40	12	5.5	15	25	28	51	38	12	M6
50	12	6.5	15	27	32	64	46.5	12	M8
63	16	6.5	20	32	40	74	56.5	16	M8

# Series C55

## Proper Auto Switch Mounting Position (Detection at Stroke End) and Its Mounting Height

Reed switch  
D-A9□

Solid state switch  
D-M9□  
D-F9BAL  
D-F9□W

∅20, 25

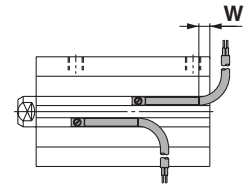
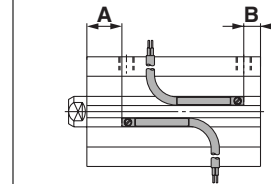
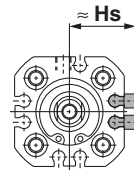

∅32, 40, 50, 63

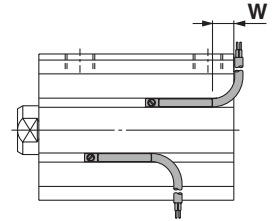
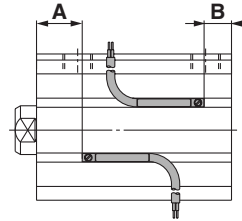
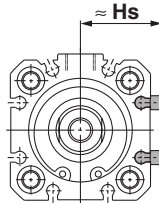

\* Figures in the table below are used as a reference when mounting the auto switches for stroke end detection. In the case of actually setting the auto switches, adjust them after confirming their operation.

(mm)

Auto switch model		D-A9□			D-M9□ D-F9□W			D-F9BAL			
Symbol		A	B	W	A	B	W	A	B	W	Hs
Bore size (mm)	20	11.5	5.5	3.5(1)	15.5	9.5	-0.5	14.5	8.5	-9.5	22
	25	11.5	7.5	5.5(3)	15.5	11.5	1.5	14.5	10.5	-7.5	24
	32	15	9	7 (4.5)	19	13	3	18	12	-6	27
	40	16	9	7 (4.5)	20	13	3	19	12	-6	30
	50	9.5	15.5	13.5(11.5)	13.5	19.5	9.5	12.5	18.5	0.5	36
	63	11.5	17.5	15.5(13.5)	15.5	21.5	11.5	14.5	20.5	2.5	41

The dimension inside ( ) is for D-A93.

Reed switch  
D-A9□V

Solid state switch  
D-M9□V  
D-F9□WV

∅20, 25

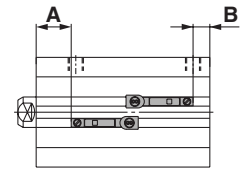
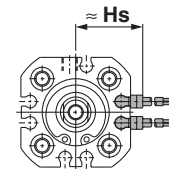

∅32, 40, 50, 63

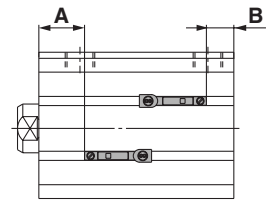
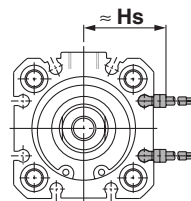

\* Figures in the table below are used as a reference when mounting the auto switches for stroke end detection. In the case of actually setting the auto switches, adjust them after confirming their operation.

(mm)

Auto switch model		D-A9□V			D-M9□V D-F9□WV		
Symbol		A	B	Hs	A	B	Hs
Bore size (mm)	20	11.5	5.5	22	15.5	9.5	24
	25	11.5	7.5	24	15.5	11.5	26
	32	15	9	27	19	13	29
	40	16	9	30	20	13	32
	50	9.5	15.5	36	13.5	19.5	38
	63	11.5	17.5	41	15.5	21.5	43

## The Number of Surfaces and Grooves Where an Auto Switch Can Be Mounted (As Direct Mounting)

The number of the surfaces and grooves where the auto switch can be mounted, by switch type, are shown in the table below.

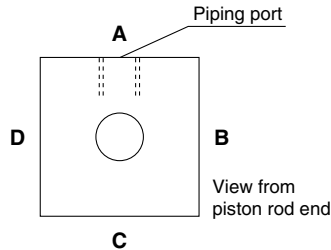

Switch model	D-A9□, M9□, F9□			
	A (Mounting groove no.)	B (Mounting groove no.)	C (Mounting groove no.)	D (Mounting groove no.)
20	○ (1)	○ (2)	○ (2)	○ (2)
25	○ (2)	○ (2)	○ (2)	○ (2)
32	○ (2)	○ (2)	○ (2)	○ (2)
40	○ (2)	○ (2)	○ (2)	○ (2)
50	○ (2)	○ (2)	○ (2)	○ (2)
63	○ (2)	○ (2)	○ (2)	○ (2)

## Operating Range

Auto switch model	Bore size (mm)					
	20	25	32	40	50	63
D-F9□W(V) D-F9BAL	5	5.5	6	6	6	6.5
D-A9□(V)	9	9	9	9	9	10.5
D-M9□(V)	3	3.5	3.5	3.5	3.5	4

\* The operating ranges are provided as guidelines including hystereses and are not guaranteed values (assuming approximately ±30% variations). They may vary significantly with ambient environments.

## Minimum Auto Switch Mounting Stroke

Bore size (mm)	Auto switch model Number of auto switches	(mm)						
		D-A9□	A9□V	D-M9□	D-M9□V	D-F9□W	D-F9□WV	D-F9BAL
20	2 pcs.	10	10	15	5	15	10	20
	1 pc.	10	5	15	5	15	5	20
25,32,40,50	2 pcs.	10	10	10	5	10	10	20
	1 pc.	10	5	10	5	10	5	20
63	2 pcs.	10	10	10	5	10	10	15
	1 pc.	5	5	5	5	10	5	15

Besides the models listed in "How to Order," the following auto switches are applicable. Refer to Best Pneumatics vol. 7/8/9/10 for detailed specifications.

Type	Part no.	Electrical entry	Features
Solid state switch	D-F9G	Grommet (In-line)	Normally closed (N.C. = b contact), 3-wire
	D-F9H		Normally closed (N.C. = b contact), 2-wire

# Series C55

## Mounting of Auto Switch

---

To mount auto switches, follow the instruction illustrated below.

### ø20 to ø63/Direct mounting

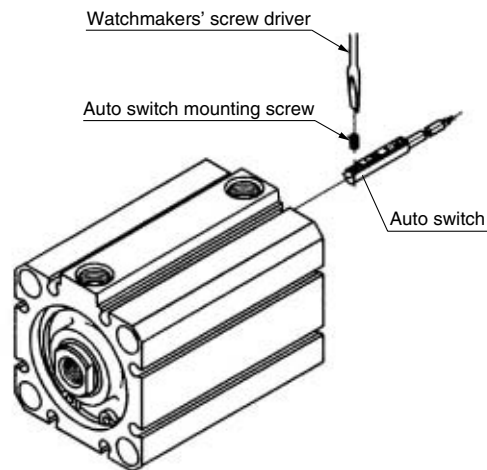

- Use a watchmakers' screwdriver with a handle 5 to 6 mm in diameter when tightening the auto switch mounting screw.  
Tightening torque should be set 0.10 to 0.20 N·m.

# Series C55

# Auto Switch Specifications

## Auto Switch Common Specifications

Type	Reed switch	Solid state switch
Leakage current	None	3-wire: 100 $\mu$ A or less 2-wire: 0.8 mA or less
Operating time	1.2 ms	1 ms or less
Impact resistance	300 m/s <sup>2</sup>	1000 m/s <sup>2</sup>
Insulation resistance	50 M $\Omega$ or more at 500 VDC Mega (between lead wire and case)	
Withstand voltage	1000 VAC for 1 minute (between lead wire and case)	
Ambient temperature	-10 to 60°C	
Enclosure	IEC529 standard IP67, Immersible construction (JIS C 0920)	

## Lead Wire Length

### Lead wire length indication

(Example) D-M9P **L**

Lead wire length

Nil	0.5 m
L	3 m
Z	5 m

- Note 1) Applicable auto switch with 5 m lead wire "Z"  
Solid state switch: Manufactured upon receipt of order as standard.
- Note 2) The standard lead wire length of solid state switch with water resistant 2-color indication type is 3 meters. (Not available 0.5 m)
- Note 3) To designate solid state switches with flexible specifications, add "-61" after the lead wire length.

(Example) D-F9NWL- **61**

Flexible specification

Note) D-M9□(V) series use flexible lead wire as standard.

## Auto Switch Hysteresis

The hysteresis is the difference between the position of the auto switch as it turns "on" and as it turns "off". A part of operating range (one side) includes this hysteresis.

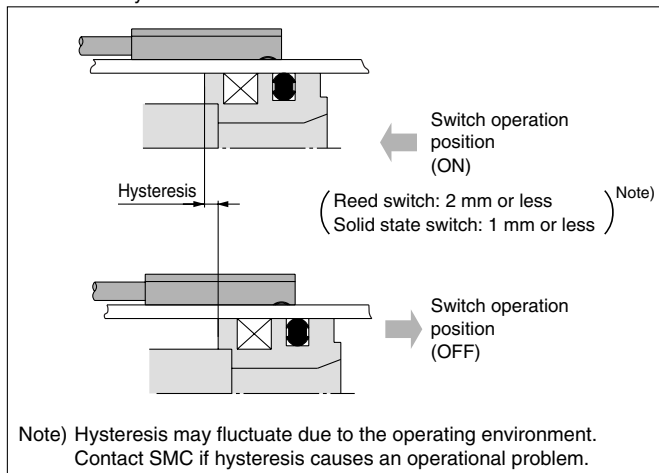

## Contact Protection Boxes: CD-P11, CD-P12

### <Applicable switch model>

D-A9/A9□V

The above auto switches do not have internal contact protection circuit.

1. Operating load is an inductive load.
  2. The length of wiring to the load is 5 m or more.
  3. The load voltage is 100 VAC.
- The contact life may be shortened. (Due to permanent energizing conditions.)

## Specifications

Part No.	CD-P11		CD-P12
Load voltage	100 VAC	200 VAC	24 VDC
Maximum load current	25 mA	12.5 mA	50 mA

\* Lead wire length — Switch connection side 0.5 m  
Load connection side 0.5 m



## Internal Circuits

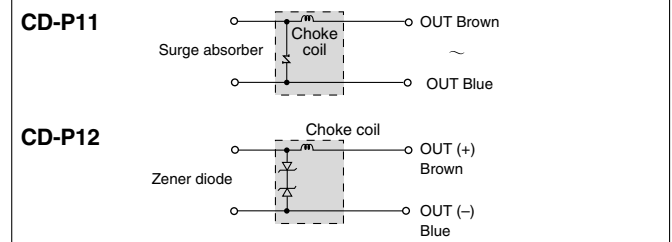

## Dimension

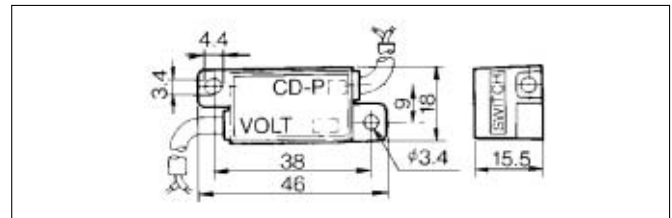

## Connection

To connect a switch unit to a contact protection box, connect the lead wire from the side of the contact protection box marked SWITCH to the lead wire coming out of the switch unit. Keep the switch as close as possible to the contact protection box, with a lead wire length of no more than 1 meter.

# Auto Switches Connections and Examples

## Basic Wiring

### Solid state 3-wire, NPN

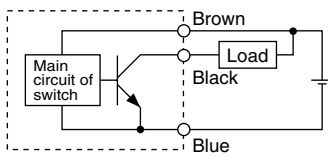

### Solid state 3-wire, PNP

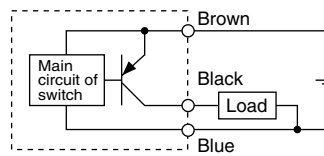

### 2-wire (Solid state)

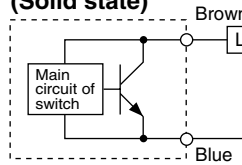

### 2-wire (Reed switch)

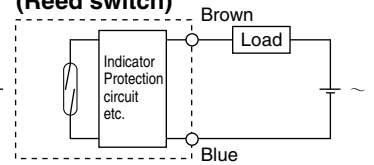

(Power supplies for switch and load are separate.)

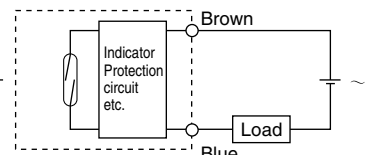
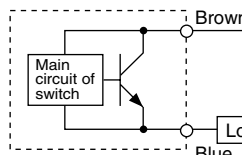
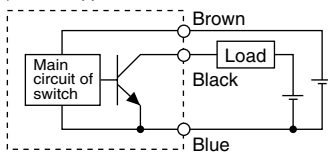

## Examples of Connection to PLC (Programmable Logic Controller)

### • Sink input specifications 3-wire, NPN

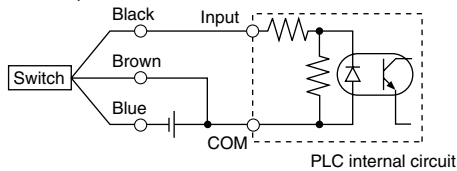

### • Source input specifications 3-wire, PNP

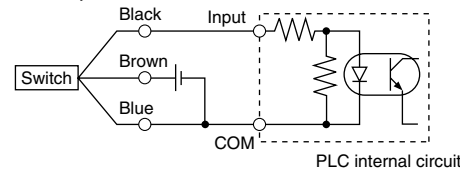

Connect according to the applicable PLC input specifications, as the connection method will vary depending on the PLC input specifications.

### 2-wire

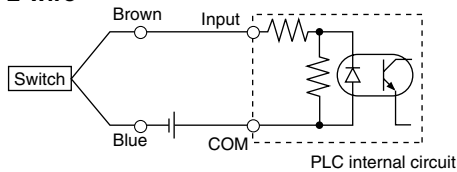

### 2-wire

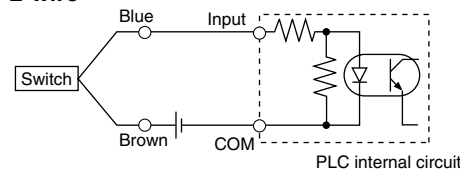

## Connection Examples for AND (Serial) and OR (Parallel)

### • 3-wire

#### AND connection for NPN output (using relays)

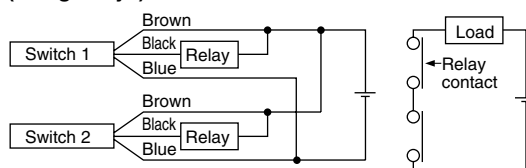

#### AND connection for NPN output (performed with switches only)

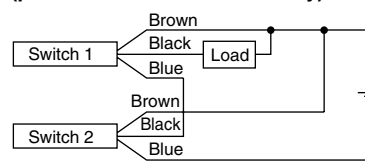

#### OR connection for NPN output

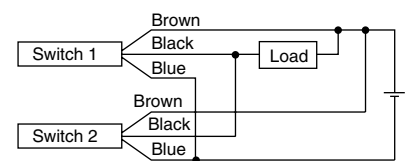

The indicator lights will light up when both switches are turned ON.

#### 2-wire with 2-switch AND connection

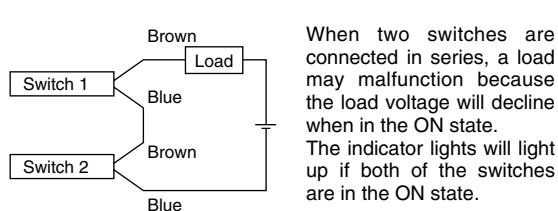

When two switches are connected in series, a load may malfunction because the load voltage will decline when in the ON state. The indicator lights will light up if both of the switches are in the ON state.

$$\begin{aligned} \text{Load voltage at ON} &= \text{Power supply voltage} - \text{Internal voltage drop} \times 2 \text{ pcs.} \\ &= 24 \text{ V} - 4 \text{ V} \times 2 \text{ pcs.} \\ &= 16 \text{ V} \end{aligned}$$

Example: Power supply is 24 VDC.  
Internal voltage drop in switch is 4 V.

#### 2-wire with 2-switch OR connection

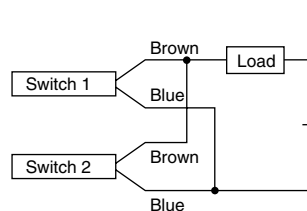

#### (Solid state)

When two switches are connected in parallel, a malfunction may occur because the load voltage will increase when in the OFF state.

$$\begin{aligned} \text{Load voltage at OFF} &= \text{Leakage current} \times 2 \text{ pcs.} \\ &\quad \times \text{Load impedance} \\ &= 1 \text{ mA} \times 2 \text{ pcs.} \times 3 \text{ k}\Omega \\ &= 6 \text{ V} \end{aligned}$$

Example: Load impedance is 3 kΩ.  
Leakage current from switch is 1 mA.

#### (Reed switch)

Because there is no current leakage, the load voltage will not increase when turned OFF. However, depending on the number of switches in the ON state, the indicator lights may sometimes dim or not light because of the dispersion and reduction of the current flowing to the switches.

# Reed Switch: Direct Mounting Style D-A90(V)/D-A93(V)/D-A96(V)



**Grommet**  
Electrical entry direction: In-line



## ⚠ Caution

### Operating Precautions

Fix the switch with appropriate screw installed on the switch body. If using other screws, switch may be damaged.

## Auto Switch Internal Circuit

### D-A90(V)

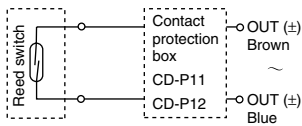

### D-A93(V)

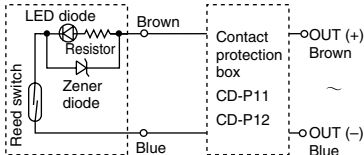

### D-A96(V)

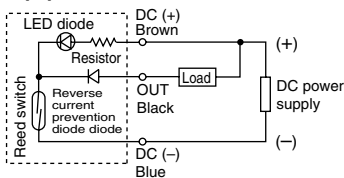

- Note) 1. Operating load is an induction load.  
2. The length of wiring to the load is 5 m or more.  
3. The load voltage is 100 VAC.

Use the contact protection box in any of the above listed situations.

The contact point life may be shortened. (Refer to page 12 for contact protection box.)

## Auto Switch Specifications

PLC: Programmable Logic Controller

D-A90/D-A90V (without indicator light)			
Auto switch model	D-A90/D-A90V		
Applicable load	IC circuit, Relay, PLC		
Load voltage	24 V AC/DC or less	48 V AC/DC or less	100 V AC/DC or less
Maximum load current	50 mA	40 mA	20 mA
Contact protection circuit	None		
Internal resistance	1 Ω or less (including lead wire length of 3 m)		
D-A93/D-A93V/D-A96/D-A96V (with indicator light)			
Auto switch model	D-A93/D-A93V		D-A96/D-A96V
Applicable load	Relay, PLC		IC circuit
Load voltage	24 VDC	100 VAC	4 to 8 VDC
Load current range and max. load current	5 to 40 mA	5 to 20 mA	20 mA
Contact protection circuit	None		
Internal voltage drop	D-A93 — 2.4 V or less (to 20 mA)/3 V or less (to 40 mA) D-A93V — 2.7 V or less		0.8 V or less
Indicator light	Red LED lights when ON		

### ● Lead wires

D-A90(V)/D-A93(V) — Oilproof vinyl heavy-duty cord:  $\phi 2.7$ , 0.18 mm<sup>2</sup> x 2 cores (Brown, Blue), 0.5 m  
D-A96(V) — Oilproof vinyl heavy-duty cord:  $\phi 2.7$ , 0.15 mm<sup>2</sup> x 3 cores (Brown, Black, Blue), 0.5 m

Note 1) Refer to page 12 for reed switch common specifications.

Note 2) Refer to page 12 for lead wire lengths.

## Weight

Unit: g

Auto switch model	D-A90	D-A90V	D-A93	D-A93V	D-A96	D-A96V
Lead wire length: 0.5 m	6	6	6	6	8	8
Lead wire length: 3 m	30	30	30	30	41	41

## Dimensions

Unit: mm

### D-A90/D-A93/D-A96

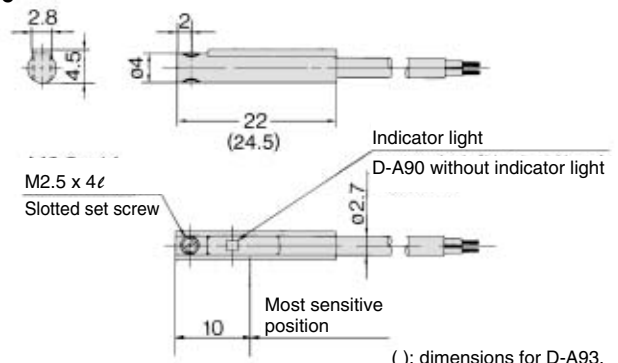

### D-A90V/D-A93V/D-A96V

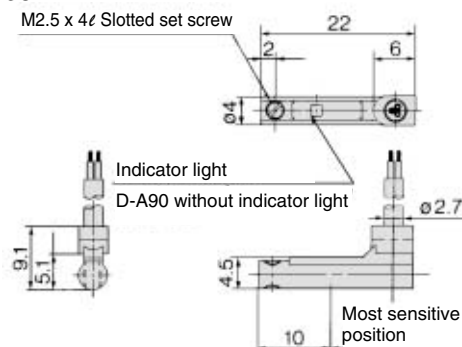

# Solid State Switch: Direct Mounting Style D-M9N(V)/D-M9P(V)/D-M9B(V)

## Grommet

- 2-wire load current is reduced (2.5 to 40 mA)
- Lead-free
- Using UL certified (style 2844) lead wire.



## ⚠ Caution

### Operating Precautions

Fix the switch with appropriate screw installed on the switch body. If using other screws, switch may be damaged.

## Auto Switch Internal Circuit

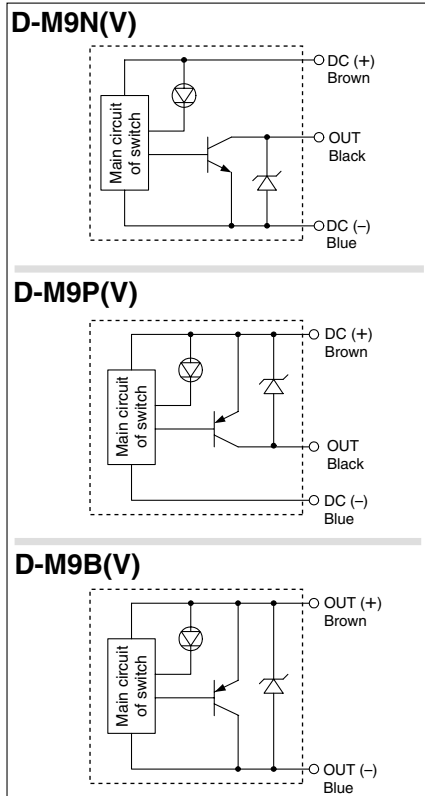

## Auto Switch Specifications

PLC: Programmable Logic Controller

D-M9□/D-M9□V (with indicator light)						
Auto switch model	D-M9N	D-M9NV	D-M9P	D-M9PV	D-M9B	D-M9BV
Electrical entry direction	In-line	Perpendicular	In-line	Perpendicular	In-line	Perpendicular
Wiring type	3-wire				2-wire	
Output type	NPN		PNP		—	
Applicable load	IC circuit, Relay, PLC				24 VDC relay, PLC	
Power supply voltage	5, 12, 24 VDC (4.5 to 28 V)				—	
Current consumption	10 mA or less				—	
Load voltage	28 VDC or less		—		24 VDC (10 to 28 VDC)	
Load current	40 mA or less				2.5 to 40 mA	
Internal voltage drop	0.8 V or less				4 V or less	
Leakage current	100 μA or less at 24 VDC				0.8 mA or less	
Indicator light	Red LED lights when ON.					

- Lead wires  
 Oilproof vinyl heavy-duty cord:  $\phi 2.7 \times 3.2$  ellipse, 0.15 mm<sup>2</sup>,  
 D-M9B(V) 0.15 mm<sup>2</sup> x 2 cores  
 D-M9N(V), D-M9P(V) 0.15 mm<sup>2</sup> x 3 cores

Note 1) Refer to page 12 for solid state switch common specifications.

Note 2) Refer to page 12 for lead wire lengths.

## Weight

Unit: g

Auto switch model	D-M9N(V)	D-M9P(V)	D-M9B(V)
Lead wire length (m)	0.5	8	7
	3	41	38
	5	68	63

## Dimensions

Unit: mm

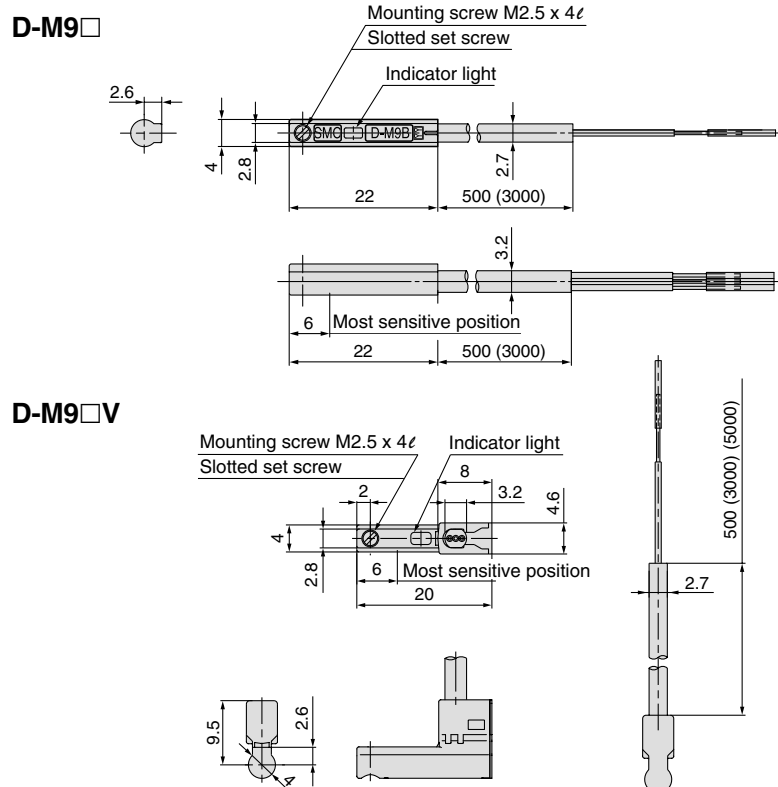



# 2-color Indication Type Solid State Switch: Direct Mounting Style D-F9NW(V)/D-F9PW(V)/D-F9BW(V)

## Grommet



### ⚠ Caution

#### Operating Precautions

Fix the switch with appropriate screw installed on the switch body. If using other screws, switch may be damaged.

### Auto Switch Internal Circuit

#### D-F9NW(V)

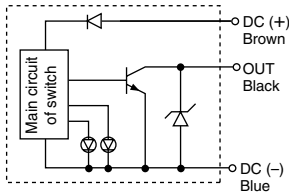

#### D-F9PW(V)

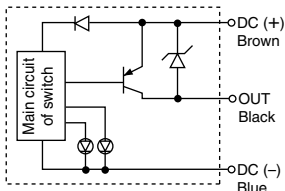

#### D-F9BW(V)

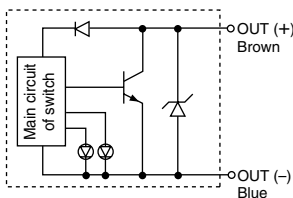

### Indicator light/Display method

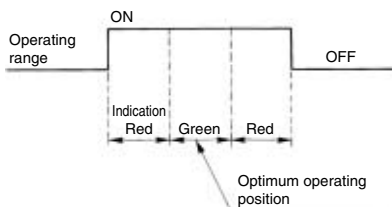

### Auto Switch Specifications

PLC: Programmable Logic Controller

D-F9□W/D-F9□WV (with indicator light)						
Auto switch model	D-F9NW	D-F9NWV	D-F9PW	D-F9PWV	D-F9BW	D-F9BWV
Electrical entry direction	In-line	Perpendicular	In-line	Perpendicular	In-line	Perpendicular
Wiring type	3-wire				2-wire	
Output type	NPN		PNP		—	
Applicable load	IC circuit, Relay, PLC				24 VDC relay, PLC	
Power supply voltage	5, 12, 24 VDC (4.5 to 28 VDC)				—	
Current consumption	10 mA or less				—	
Load voltage	28 VDC or less		—		24 VDC (10 to 28 VDC)	
Load current	40 mA or less		80 mA or less		5 to 40 mA	
Internal voltage drop	1.5 V or less (0.8 V or less at 10 mA load current)		0.8 V or less		4 V or less	
Leakage current	100 μA or less at 24 VDC				0.8 mA or less	
Indicator light	Operating position ..... Red LED lights when ON. Optimum operating position ..... Green LED lights when ON.					

#### ● Lead wires

Oilproof vinyl heavy-duty cord:  $\phi 2.7$ , 0.15 mm<sup>2</sup> x 3 cores (Brown, Black, Blue),  
0.18 mm<sup>2</sup> x 2 cores (Brown, Blue), 0.5 m

Note 1) Refer to page 12 for solid state switch common specifications.

Note 2) Refer to page 12 for lead wire lengths.

### Weight

Unit: g

Auto switch model	D-F9NW(V)	D-F9PW(V)	D-F9BW(V)
Lead wire length (m)	0.5	7	7
	3	34	32
	5	56	52

### Dimensions

Unit: mm

#### D-F9□W

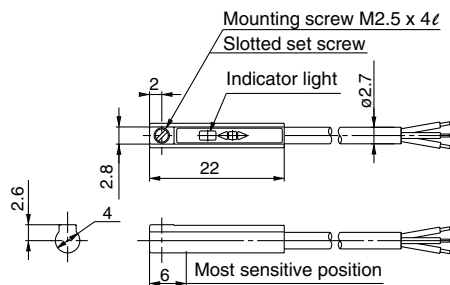

#### D-F9□WV

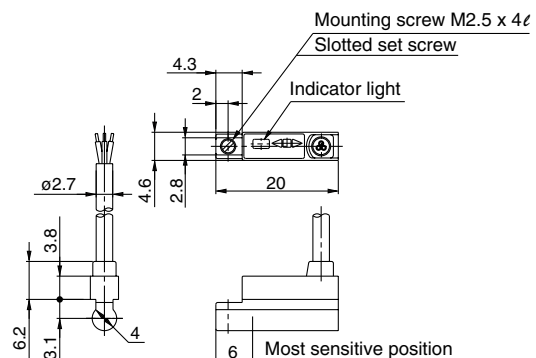

# Water Resistant 2-color Indication Type Solid State Switch: Direct Mounting Style D-F9BAL



## Grommet

Water (coolant) resistant type



## Caution

### Operating Precautions

1. Please consult with SMC if using coolant liquid other than water based solution.
2. Fix the switch with appropriate screw installed on the switch body. If using other screws, switch may be damaged.

## Auto Switch Specifications

PLC: Programmable Logic Controller

D-F9BAL (with indicator light)	
Auto switch model	D-F9BAL
Wiring type	2-wire
Output type	—
Applicable load	24 VDC relay, PLC
Power supply voltage	—
Current consumption	—
Load voltage	24 VDC (10 to 28 VDC)
Load current	5 to 30 mA
Internal voltage drop	5 V or less
Leakage current	1 mA or less at 24 VDC
Indicator light	Operating position ..... Red LED lights when ON. Optimum operating position ..... Green LED lights when ON.

### ● Lead wires

Oilproof vinyl heavy-duty cord:  $\phi 2.7$ , 2 cores (Brown, Blue), 0.18 mm<sup>2</sup>, 0.5 m  
 Note 1) Refer to page 12 for solid state switch common specifications.  
 Note 2) Refer to page 12 for lead wire lengths.

## Weight

Unit: g

Auto Switch Model	D-F9BA	
Lead wire length (m)	0.5	—
	3	37
	5	57

## Auto Switch Internal Circuit

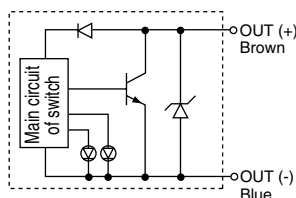

## Indicator light/Display method

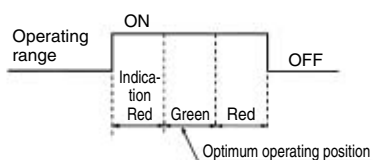

## Dimensions

Unit: mm

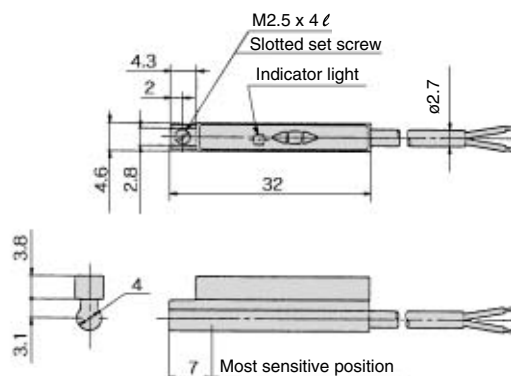

# ISO Standards [ISO/21287] Compact Cylinder (ATEX directive category 2)

## Series 55-C55

∅20, ∅25, ∅32, ∅40, ∅50, ∅63



### How to Order

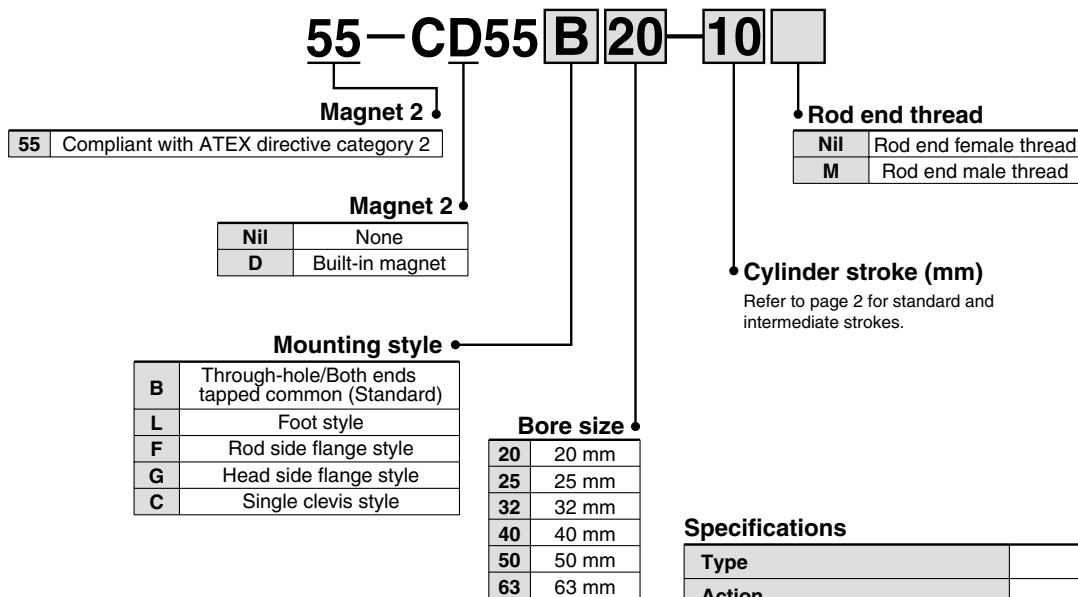

### Specifications

Type	Pneumatic (non-lube)
Action	Double acting, Single rod
Fluid	Air
Proof pressure	1.5 MPa
Maximum operating pressure	1.0 MPa
Minimum operating pressure	0.05 MPa
Ambient and fluid temperature	-10 to 60°C (with no freezing)
Cushion	Rubber bumper on both side
Stroke length tolerance	+1.0 mm 0
Mounting	Through-holes/Both end tapped
Piston speed	50 to 500 mm/s

When using an Auto switch, select the appropriate switch from the following table and order it separately.

### Applicable auto switch specifications

Auto switch only conforms to Category 3. (II 3GD EEx nA II T5x -10°C ≤ Ta ≤ +60°C IP67)  
For detailed specifications on the A93(V), A90(V), and M9P(V), please refer to page 14, 15.  
(Note: Reed auto switches for 100 VAC and 100 VDC are not within the specification.)

Type	Model	Electrical entry	Indicator light	Wiring (output)	Load voltage			Lead wire length (m) *			Applicable load
					DC	AC		0.5 (Nil)	3 (L)	5 (Z)	
Reed switch	D-A93V□-588	Grommet (Perpendicular)	Yes	2-wire	24 V	12 V	—	●	●	●	Relay, PLC
	D-A90V□-588		No		24 V or less	48 V	48 V or less	●	●	—	
	D-A93□-588	Grommet (in-line)	Yes		24 V	12 V	—	●	●	●	
	D-A90□-588		No		24 V or less	48 V	48 V or less	●	●	—	
Solid state switch	D-M9PV□-588	Grommet (Perpendicular)	Yes	3-wire (PNP)	24 V	5 V, 12 V	—	●	●	○	IC circuit
	D-M9P□-588	Grommet (in-line)						●	●	○	

\* Lead wire length symbols: 0.5 m ..... Nil (Example) D-A93-588  
3 m ..... L (Example) D-A93L-588  
5 m ..... Z (Example) D-A93Z-588

\* ○ solid state auto switch is available after receiving an order.

(Note) When mounting an auto switch on a 55-series (Category 2) model, the ATEX class of the cylinder with auto switch changes to Category 3, which is the same class as the auto switch.