



Clean One-touch Fittings and Tubing
Series KP/KPQ/KPG

Clean One-Touch Fittings and Series
TPH/TPS Clean Tubing



- Non-Metallic Contact Areas
- Parts Cleaned, Assembled and Double Packaged in a Clean Room
- Completely Oil Free

One-touch fittings and tubing for clean room blow off systems and drive air systems

One-touch fittings (for blow off)

Series KP

- Completely oil free
- Liquid-contact areas are non-metallic
- Parts cleaned, assembled and double packaged in a clean room
- Can be used for vacuum (-100kPa) (-14.5 psi)



Series KP

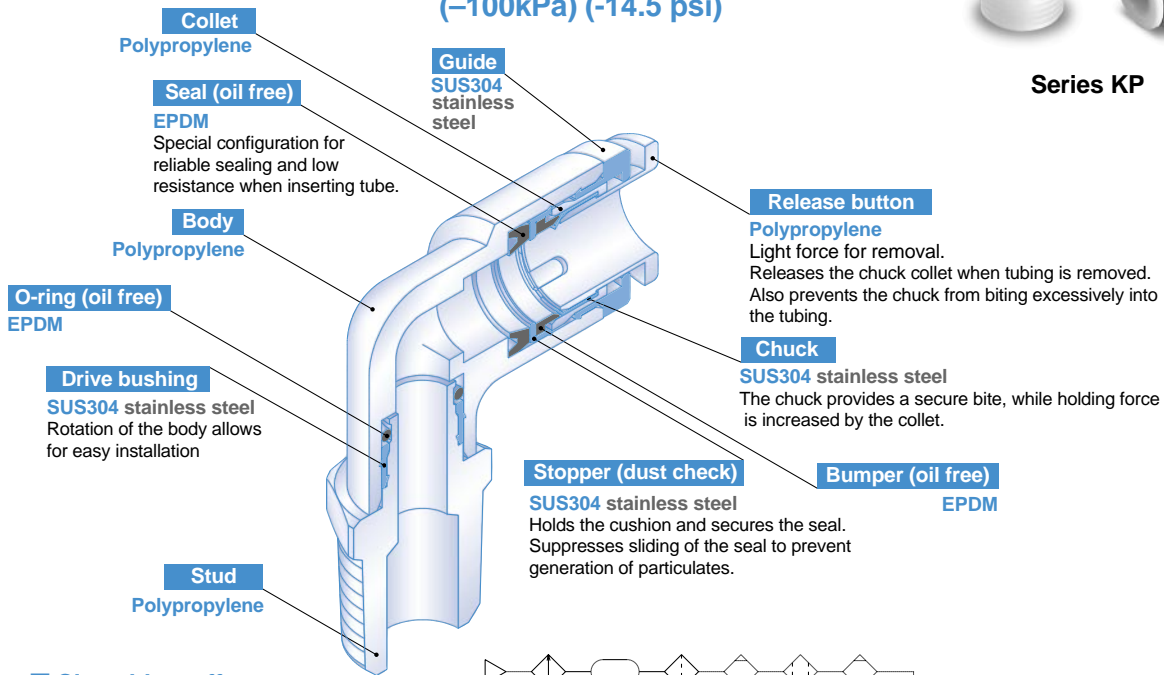

■ Clean blow off system

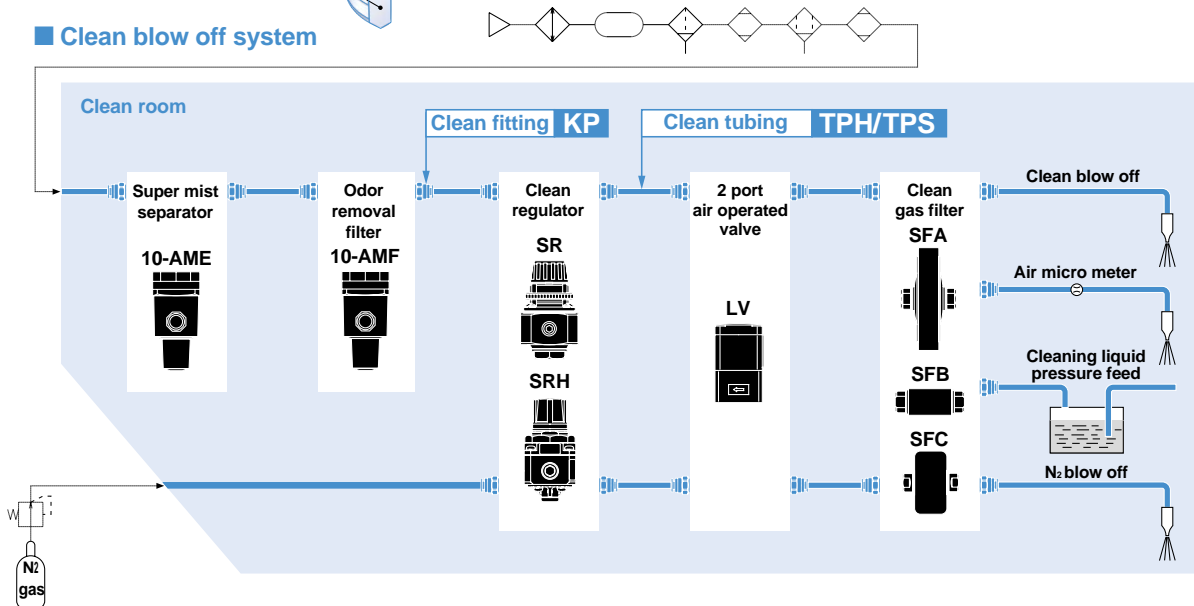

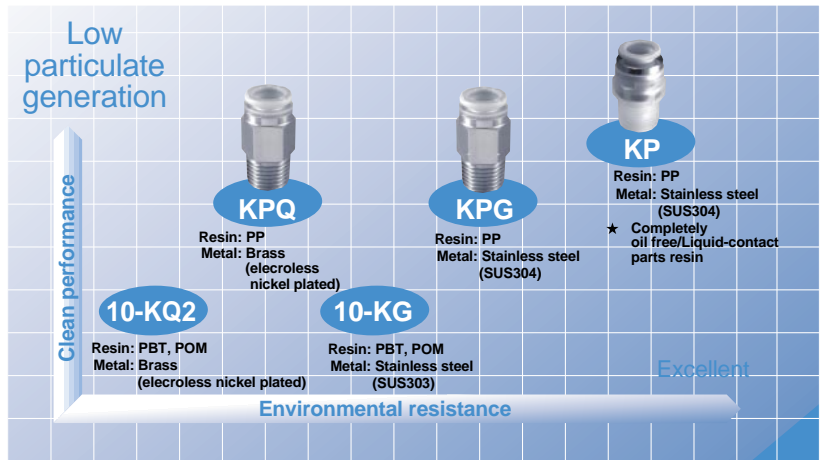
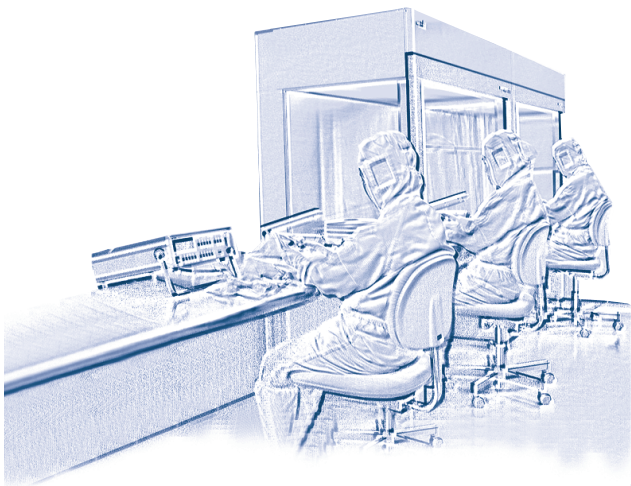

One-touch fittings (for drive system air piping)

Series KPQ/KPG

Brass (electroless nickel plated) Stainless steel (SUS304)

- M5 size standardized
- Resin parts are P.P. (polypropylene)

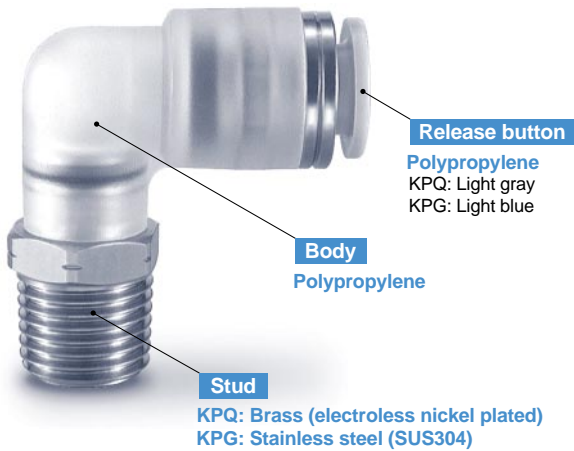

Series KPQ

Series KPG



Male connector

Drive air piping system

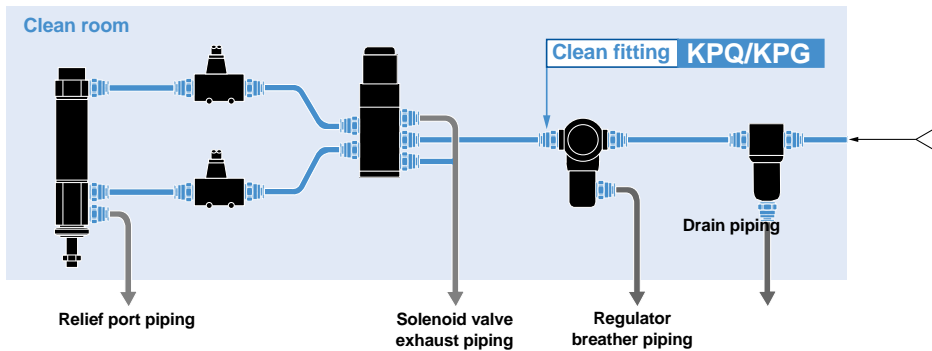

Polyolefin Tubing Series TPH/TPS



Series	Material	Tubing O.D. mm					Color	Tubing length m
		4	6	8	10	12		
TPH	Polyolefin	●	●	●	●	●	White, Black, Red, Blue	20
TPS	Soft Polyolefin	●	●	●	●	●	Yellow, Green	100

1ft = 0.3048
1in = 25.4mm



⚠ Caution

Series KP is a line of special One-touch fittings for use in clean room blow off and washing lines. Consult SMC regarding other types of applications.

Seal material: The durability of EPDM with respect to mineral oils is inferior, which makes it unsuitable for piping in general pneumatic equipment.

Recommended Applicable Tubing

Tubing material	Polyolefin: Series TPH Soft polyolefin: Series TPS
Tubing O.D.	ø4, ø6, ø8, ø10, ø12

Note 1) Polyurethane tubing: Series TU, Nylon tubing: Series T, and Soft nylon tubing: Series TS can also be used. However, the degree of clean performance will be reduced.

Note 2) Due to the softness of polyurethane tubing, it may fold when being inserted. Hold the end of the tubing and insert it all the way in. Refer to "Installation and Removal of Tubing" on page 15.)

Specifications

Particulate generation grade	Grade 1 Note 1)
Fluid	Air, Nitrogen gas, Water (pure water) Note 2)
Max operating pressure 20°C (68°F)	1MPa (145 psi ^o) Note 3)
Operating vacuum pressure	-100kPa (-14.5 psi)
Proof pressure 20°C (68°F)	3MPa (435 psi)
Ambient and fluid temperature	-20°C to 80°C (-4 to 176°F)
Threads	JIS B0203 (taper threads for piping)

Note 1) Refer to particulate generation grade classifications.

Note 2) Consult SMC regarding other fluids.

Note 3) The maximum operating pressure is the value at 20°C (68°F). Refer to the operating pressure curve for other temperatures.

Principal Part Materials

Body	Polypropylene resin
Stud	Polypropylene resin
Chuck	SUS304 stainless steel
Guide, Stopper, Drive bushing	SUS304 stainless steel
Collet, Release button	Polypropylene resin
Seal, O-ring, Bumper	EPDM

Particulate Generation Grade Classifications

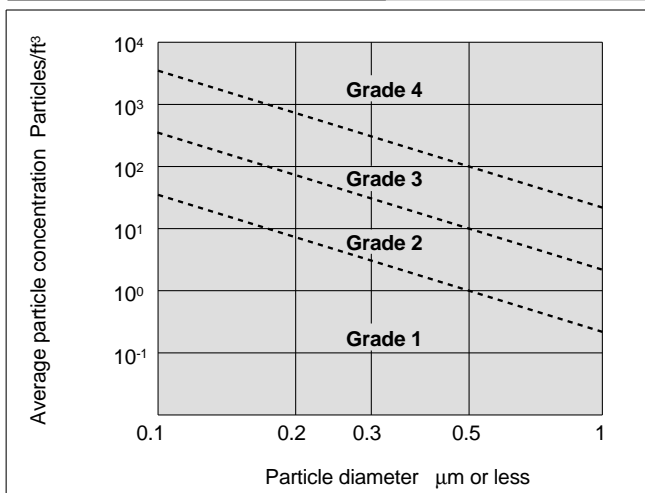

Relationship of Operating Temperature and Maximum Operating Pressure

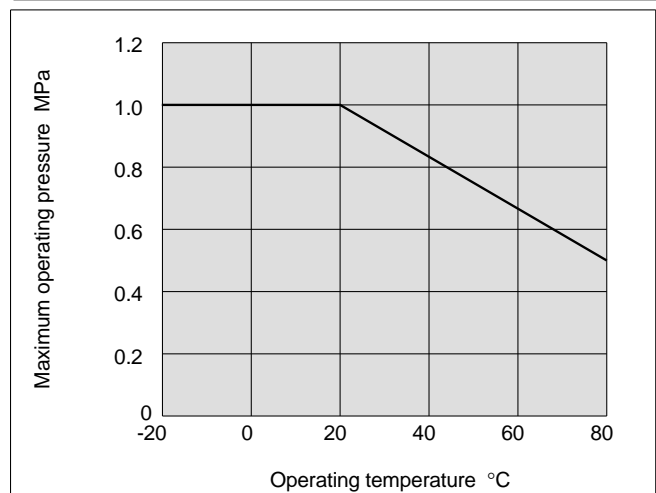

1MPa = 145 psi
°F = (1.8 x °C) + 32°

How to Order

KP H 06 01

Clean One-touch fitting (for blow off)

Model

H	Male connector, Straight union
L	Union elbow, Male elbow
T	Male branch tee, Union tee
Y	Male run tee
U	Male branch, Union "Y"
R	Plug-in reducer

Port size/Applicable tubing O.D.

Thread connection	01	R 1/8
	02	R 1/4
	03	R 3/8
	04	R 1/2
Tubing (rod) connection	00	Same dia. tubing
	04	ø4
	06	ø6
	08	ø8
	10	ø10
	12	ø12

Different dia. tubing (plug-in reducer)

Applicable tubing O.D.

04	ø4
06	ø6
08	ø8
10	ø10
12	ø12

KP P 08

Applicable fitting size

04	ø4
06	ø6
08	ø8
10	ø10
12	ø12

Plug

Clean One-touch fitting

Construction

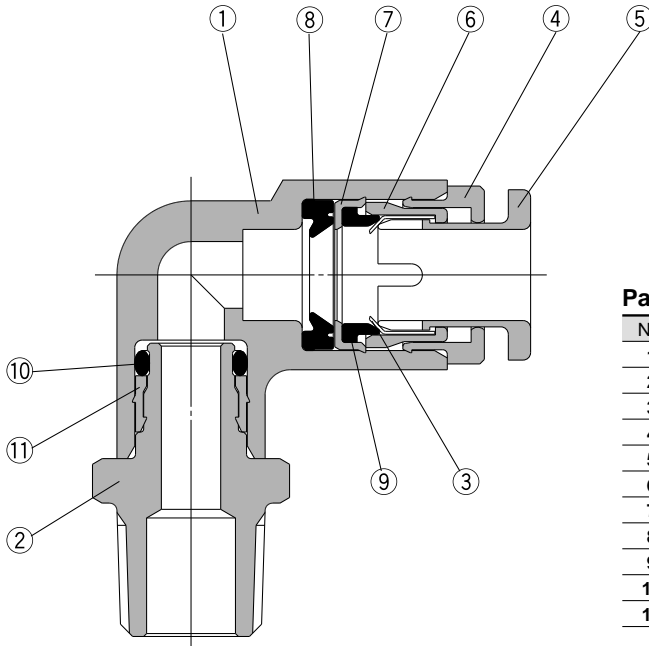

Parts list

No.	Description	Material
1	Body	Polypropylene resin
2	Stud	Polypropylene resin
3	Chuck	SUS304 stainless steel
4	Guide	SUS304 stainless steel
5	Release button	Polypropylene resin (color: light green)
6	Collet	Polypropylene resin
7	Stopper	SUS304 stainless steel
8	Seal	EPDM
9	Bumper	EPDM
10	O-ring	EPDM
11	Drive bushing	SUS304 stainless steel

Series KP

Clean One-Touch Fittings

Dimensions (mm)

1in = 25.4mm, 1g = 0.0353oz

Male Connector: KPH



Applicable tubing O.D. mm	Connection threads R	Model	H (width across flats)	L	A*	M	Effective area mm ²		Weight g
							TPH	TPS	
4	1/8	KPH04-01	12	25.4	21.5	18	4	4	3
	1/4	KPH04-02	14	25.4	19.5				4
6	1/8	KPH06-01	14	25.9	22	19.5	10	10	4
	1/4	KPH06-02	16	26.4	20.5				5
8	1/8	KPH08-01	17	32.3	28.5	21.5	26	18	6
	1/4	KPH08-02	19	30.3	24.5				7
10	1/4	KPH10-02	19	37.5	32	24	41	29	10
	3/8	KPH10-03	21	33	27				11
12	3/8	KPH12-03	22	34	28	25	58	46	12
	1/2	KPH12-04	24	34.5	27				13

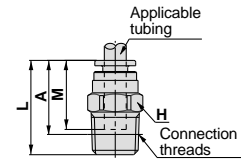

* Reference dimension for R threads after installation

Male Elbow: KPL



Applicable tubing O.D. mm	Connection threads R	Model	H (width across flats)	Note 1) ϕD_1	ϕD_2	L ₁	L ₂	A*	M	Effective area mm ²		Weight g
										TPH	TPS	
4	1/8	KPL04-01	12	10.4	10	20.7	23.2	24.5	18	3.5	3.5	4
	1/4	KPL04-02	14									27.2
6	1/8	KPL06-01	12	12.8	10	22.8	24.4	27	19.5	9	9	5
	1/4	KPL06-02	14									28.4
8	1/8	KPL08-01	14	15.2	12	26.3	26.6	30	21.5	22	15	8
	1/4	KPL08-02	16									29.4
10	1/4	KPL10-02	17	18.5	17	29.4	32.1	35.5	24	35	25	13
	3/8	KPL10-03	19									33.1
12	3/8	KPL12-03	17	20.9	22	31.4	34.3	38.5	25	50	40	15
	1/2	KPL12-04	21									38.3

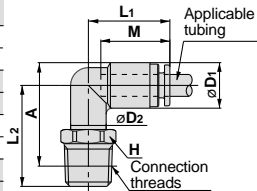

* Reference dimension for R threads after installation Note 1) ϕD_1 indicates the maximum diameter.

Male Branch Tee: KPT



Applicable tubing O.D. mm	Connection threads R	Model	H (width across flats)	Note 1) ϕD_1	ϕD_2	L ₁	L ₂	A*	M	Effective area mm ²		Weight g
										TPH	TPS	
4	1/8	KPT04-01	12	10.4	10	20.7	23.2	24.5	18	4.1	4.1	6
	1/4	KPT04-02	14									27.2
6	1/8	KPT06-01	12	12.8	10	22.8	24.4	27	19.5	11	11	8
	1/4	KPT06-02	14									28.4
8	1/8	KPT08-01	14	15.2	12	26.3	26.6	30	21.5	26.3	18.2	12
	1/4	KPT08-02	16									29.4
10	1/4	KPT10-02	17	18.5	17	29.4	32.1	35.5	24	40.8	29	20
	3/8	KPT10-03	19									33.1
12	3/8	KPT12-03	17	20.9	22	31.4	34.3	38.5	25	57.2	45.2	24
	1/2	KPT12-04	21									38.3

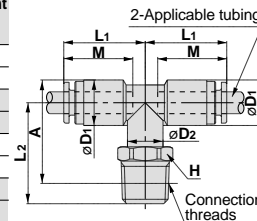

* Reference dimension for R threads after installation Note 1) ϕD_1 indicates the maximum diameter.

Male Run Tee: KPY



Applicable tubing O.D. mm	Connection threads R	Model	H (width across flats)	Note 1) ϕD_1	ϕD_2	L ₁	L ₂	A*	M	Effective area mm ²		Weight g
										TPH	TPS	
4	1/8	KPY04-01	12	10.4	10	20.7	23.2	40	18	7.5	7.5	6
	1/4	KPY04-02	14									27.2
6	1/8	KPY06-01	12	12.8	10	22.8	24.4	43	19.5	11	11	8
	1/4	KPY06-02	14									28.4
8	1/8	KPY08-01	14	15.2	12	26.3	26.6	49	21.5	21	21	12
	1/4	KPY08-02	16									29.4
10	1/4	KPY10-02	17	18.5	17	29.4	32.1	56	24	45	45	19
	3/8	KPY10-03	19									33.1
12	3/8	KPY12-03	17	20.9	22	31.4	34.3	59.5	25	57	57	21
	1/2	KPY12-04	21									38.3

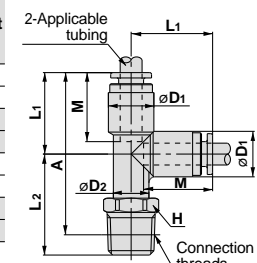

* Reference dimension for R threads after installation Note 1) ϕD_1 indicates the maximum diameter.

Male Branch "Y": KPU



Applicable tubing O.D. mm	Connection threads R	Model	H (width across flats)	Note 1) ϕD	L	P	A*	M	Effective area mm ²		Weight g
									TPH	TPS	
4	1/8	KPU04-01	12	10.4	45.4	10.4	41.5	18	7.5	7.5	7
	1/4	KPU04-02	14								49.4
6	1/8	KPU06-01	14	12.8	49.6	12.8	45.5	19.5	18	18	9
	1/4	KPU06-02	16								52.4
8	1/8	KPU08-01	17	15.2	56.7	15.2	52.5	21.5	26	26	15
	1/4	KPU08-02	19								61.3
10	1/4	KPU10-02	19	18.5	64.5	18.5	59	24	45	45	23
	3/8	KPU10-03	21								67.5
12	3/8	KPU12-03	22	20.9	69.7	20.9	63.5	25	70	70	29
	1/2	KPU12-04	24								72.7

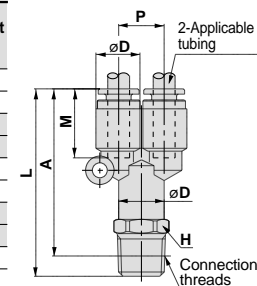

* Reference dimension for R threads after installation Note 1) ϕD indicates the maximum diameter.

Clean One-Touch Fittings

Series KP

Dimensions (mm)

1in = 25.4mm, 1g = 0.0353oz

Straight Union: KPH



Applicable tubing O.D. mm	Model	Note 1) $\varnothing D$	L	M	Effective area mm ²		Weight g
					TPH	TPS	
4	KPH04-00	10.4	37.4	18	4	4	4
6	KPH06-00	12.8	39.6	19.5	10	10	6
8	KPH08-00	15.2	44.4	21.5	26	18	10
10	KPH10-00	18.5	48.6	24	41	29	15
12	KPH12-00	20.9	50.6	25	58	46	18

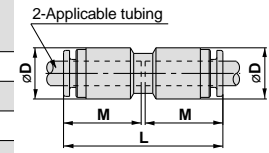

Note 1) $\varnothing D$ indicates the maximum diameter.

Elbow: KPL



Applicable tubing O.D. mm	Model	Note 1) $\varnothing D$	L	Q	M	Effective area mm ²		Weight g
						TPH	TPS	
4	KPL04-00	10.4	20.7	4.5	18	3.5	3.5	3
6	KPL06-00	12.8	22.8	5.3	19.5	9	9	7
8	KPL08-00	15.2	26.3	6	21.5	22	15	11
10	KPL10-00	18.5	29.4	6.8	24	35	25	16
12	KPL12-00	20.9	31.4	7.5	25	50	40	20

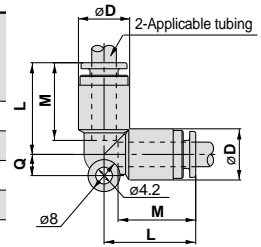

Note 1) $\varnothing D$ indicates the maximum diameter.

Union Tee: KPT



Applicable tubing O.D. mm	Model	Note 1) $\varnothing D$	L	Q	M	Effective area mm ²		Weight g
						TPH	TPS	
4	KPT04-00	10.4	20.7	4.5	18	4	4	7
6	KPT06-00	12.8	22.8	5.3	19.5	10	10	9
8	KPT08-00	15.2	26.3	6	21.5	26	18	16
10	KPT10-00	18.5	29.4	6.8	24	41	29	25
12	KPT12-00	20.9	31.4	7.5	25	58	46	29

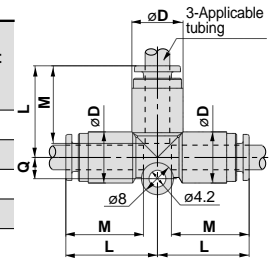

Note 1) $\varnothing D$ indicates the maximum diameter.

Union "Y": KPU



Applicable tubing O.D. mm	Model	Note 1) $\varnothing D$	L ₁	L ₂	P	Q	M	Effective area mm ²		Weight g
								TPH	TPS	
4	KPU04-00	10.4	38.8	20.6	10.4	9.7	18	4	4	7
6	KPU06-00	12.8	42.1	22.8	12.8	11.7	19.5	10	10	10
8	KPU08-00	15.2	48.7	27.5	15.2	13.7	21.5	26	18	17
10	KPU10-00	18.5	54	30.7	18.5	16.1	24	41	29	26
12	KPU12-00	20.9	57.2	32.9	20.9	18.1	25	58	46	32

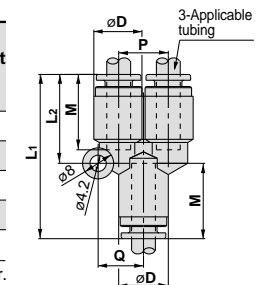

Note 1) $\varnothing D$ indicates the maximum diameter.

Plug-in Reducer: KPR



Applicable tubing O.D. mm	Applicable fitting size $\varnothing d$	Model	Note 1) $\varnothing D$	L	A	M	Effective area mm ²		Weight g
							TPH	TPS	
4	6	KPR04-06	10.4	39.4	20.1	18	4	4	3
	8	KPR04-08		41.9	20.2				
6	8	KPR06-08	12.8	42.5	20.8	19.5	10	10	4
		KPR06-10		45	21.2				
8	10	KPR08-10	15.2	47	23.2	21.5	26	18	5
		KPR08-12		48	23.2				
10	12	KPR10-12	18.5	50.5	25.7	24	41	29	9

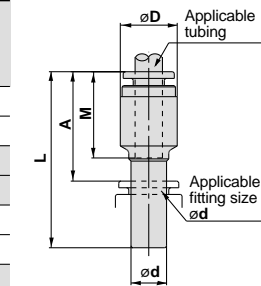

Note 1) $\varnothing D$ indicates the maximum diameter.

Plug: KPP



Applicable fitting size $\varnothing d$	Model	$\varnothing D$	L	A	Weight g
4	KPP-04	6	32	13.8	0.4
6	KPP-06	8	35	15.7	0.7
8	KPP-08	10	39	17.3	1.1
10	KPP-10	12	43	19.2	1.7
12	KPP-12	14	45.5	20.7	2.5

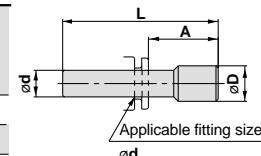



Series KPQ
Brass (electroless nickel plated)
Release button: Light gray



Series KPG
Stainless steel (SUS304)
Release button: Light blue

Recommended Applicable Tubing

Tubing material	Polyurethane: 10-series
Tubing O.D.	ø4, ø6, ø8, ø10, ø12

Polyurethane tubing: Series TU, Nylon tubing: Series T, and Soft nylon tubing: Series TS can also be used. However, the degree of clean performance will be reduced.

Specifications

Particulate generation grade	Grade 1 ^{Note 1)}
Fluid	Air
Max operating pressure 20°C (68°F)	1MPa (145 psi) ^{Note 2)}
Operating vacuum pressure	-100kPa (-14.5 psi)
Proof pressure 20°C (68°F)	3MPa (435 psi)
Ambient and fluid temperature	-5°C to 60°C (23°F to 140°F)
Threads	JIS B0203 (taper threads for piping)

Note 1) Refer to particulate generation grade classifications

This falls outside of the grade because grease is applied to the internal seal materials.

Note 2) The maximum operating pressure is the value at 20°C (68°F). Refer to the operating pressure curve for other temperatures.

Principal Part Materials

Model	Series KPQ	Series KPG
Body	Polypropylene resin	
Stud	Brass (electroless nickel plated)	SUS304 stainless steel
Chuck	SUS304 stainless steel	
Guide, Stopper	Brass (electroless nickel plated)	SUS304 stainless steel
Collet, Release button	Polypropylene resin	
Seal, O-ring, Bumper	NBR	

Particulate Generation Grade Classifications

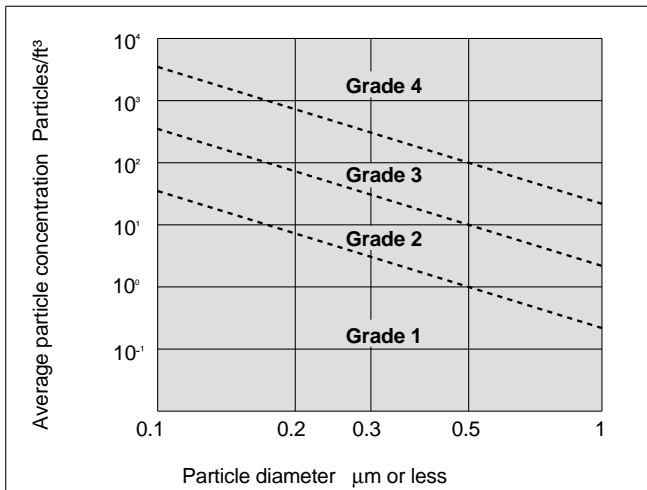

Relationship of Operating Temperature and Maximum Operating Pressure

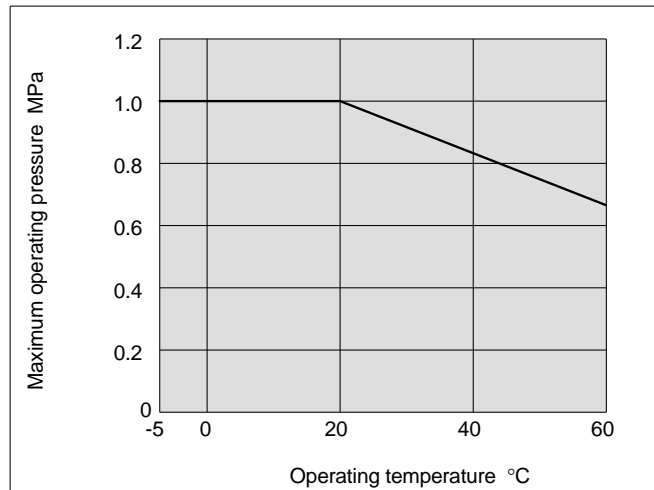

1MPa = 145psi
°F = (1.8 x °C) + 32°

How to Order

KP Q H 06 01 **KP P 08**

● Clean One-touch fitting

● Specifications

Symbol	Specifications (metal part materials)
Q	Brass (electroless nickel plated)
G	Stainless steel (SUS304)

● Model

H	Male connector, Straight union
L	Union elbow, Male elbow
T	Male branch tee, Union tee
Y	Male run tee
U	Male branch, Union "Y"
R	Plug-in reducer

● Port size/Applicable tubing O.D.

Thread connection	Applicable tubing O.D.	
		Series KPQ
M5	M5 x 0.8	
01	R 1/8	
02	R 1/4	
03	R 3/8	
04	R 1/2	
00	Same dia. tubing	
04	ø4	Different dia. tubing (plug-in reducer)
06	ø6	
08	ø8	
10	ø10	
12	ø12	

● Applicable tubing O.D.

04	ø4
06	ø6
08	ø8
10	ø10
12	ø12

● Applicable fitting size

04	ø4
06	ø6
08	ø8
10	ø10
12	ø12

● Plug

● Clean One-touch fitting

Construction

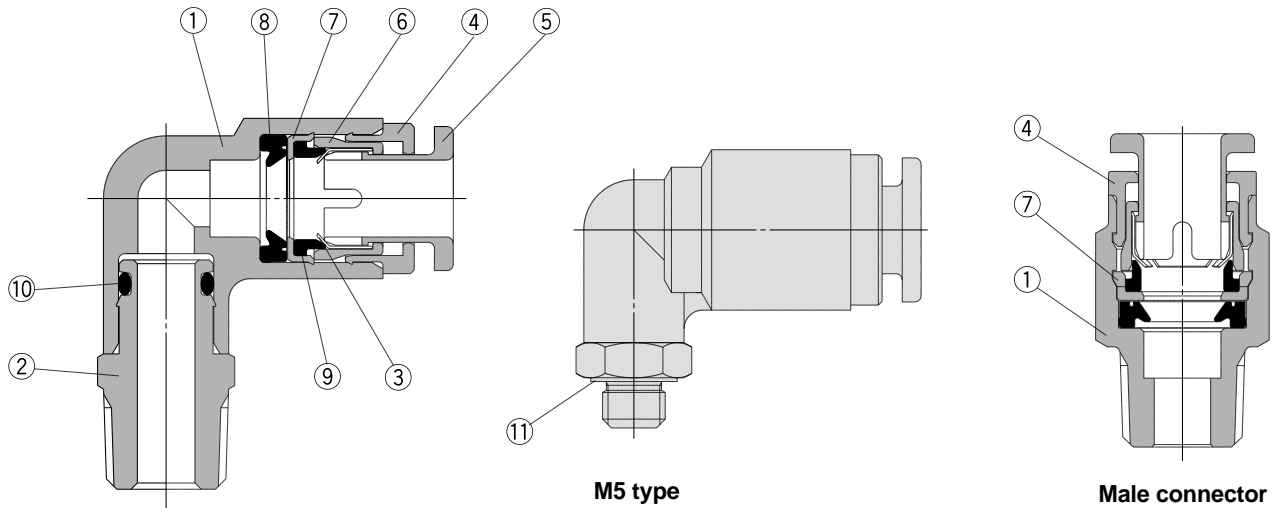

Parts list

No.	Description	Material	
		Series KPQ	Series KPG
1	Body	Polypropylene resin	
		With male connector	Brass (electroless nickel plated)
2	Stud	Brass (electroless nickel plated)	SUS304 stainless steel
3	Chuck	SUS304 stainless steel	
4	Guide	Brass (electroless nickel plated)	
		With male connector	Polypropylene resin
5	Release button	Polypropylene resin (color: light gray)	Polypropylene resin (color: light blue)
6	Collet	Polypropylene resin	
7	Stopper	SUS304 stainless steel	
		With male connector	Polypropylene resin
8	Seal	NBR	
9	Bumper	NBR	
10	O-ring	NBR	
11	Gasket	SUS304 stainless steel + NBR	

Dimensions (mm)

1in = 25.4mm, 1g = 0.0353oz

Male Connector: KPQH, KPGH

(M5)



(R)



Applicable tubing O.D. mm	Connection threads R	Model		H (width across flats)	øD	L	A*	M	Effective area mm ²		Weight g
									TPH	TPS	
4	M5	KPQH04-M5	—	8	10	25.4	22.5	18	4	4	4
		—	KPGH04-M5			25.9					
	1/8	KPQH04-01	KPGH04-01	10	—	25.4	19.5				
6	M5	KPQH06-M5	—	8	12	26.3	23	19.5	10	10	5
		—	KPGH06-M5			26.8					
	1/8	KPQH06-01	KPGH06-01	12	—	25.6	19.5				
8	M5	KPQH08-M5	—	8	14	32.6	26.5	21.5	26	18	14
		—	KPGH08-M5			30.6					
	1/4	KPQH08-02	KPGH08-02	14	—	30.6	24.5				
10	M5	KPQH10-M5	—	8	17	37.6	31.5	24	41	29	24
		—	KPGH10-M5			33					
	3/8	KPQH10-03	KPGH10-03	17	—	33	26.5				
12	M5	KPQH12-M5	—	8	19	34.1	27.5	25	58	46	23
		—	KPGH12-M5			34.1					
	1/2	KPQH12-04	KPGH12-04	22	—	34.1	26				

* Reference dimension for R threads after installation

(M5)

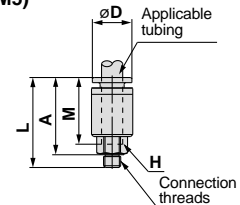

(R)

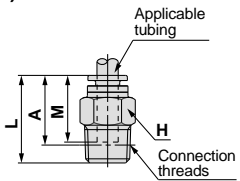

Male Elbow: KPQL, KPGL

(M5)



(R)



Applicable tubing O.D. mm	Connection threads R	Model		H (width across flats)	Note 1) øD ₁	øD ₂	L ₁	L ₂	A*	M	Effective area mm ²		Weight g
											TPH	TPS	
4	M5	KPQL04-M5	KPGL04-M5	8	10.4	8	20.7	15.3	17	18	4	4	4
		—	—					22	21				
	1/4	KPQL04-02	KPGL04-02	14	—	26	25						
6	M5	KPQL06-M5	KPGL06-M5	8	12.8	10	22.8	15.8	18.5	19.5	10	10	6
		—	—					23.2	23.5				
	1/4	KPQL06-02	KPGL06-02	14	—	27.2	27.5						
8	M5	KPQL08-M5	KPGL08-M5	8	15.2	12	26.3	24.4	26	21.5	26	18	13
		—	—					28.4	30				
	1/4	KPQL08-02	KPGL08-02	14	—	29.9	33						
10	M5	KPQL10-M5	KPGL10-M5	8	18.5	17	29.4	29.9	33	24	41	29	26
		—	—					31.9	34.5				
	3/8	KPQL10-03	KPGL10-03	17	—	33.1	37						
12	M5	KPQL12-M5	KPGL12-M5	8	20.9	17	31.4	33.1	37	25	58	46	38
		—	—					37.1	39.5				
	1/2	KPQL12-04	KPGL12-04	22	—	37.1	39.5						

* Reference dimension for R threads after installation Note 1) øD₁ indicates the maximum diameter.

(M5)

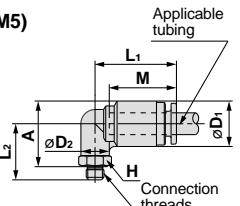

(R)

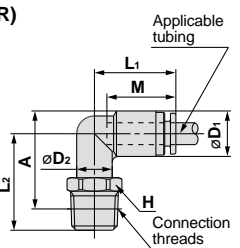

Union Tee: KPQT, KPGT

(M5)



(R)



Applicable tubing O.D. mm	Connection threads R	Model		H (width across flats)	Note 1) øD ₁	øD ₂	L ₁	L ₂	A*	M	Effective area mm ²		Weight g
											TPH	TPS	
4	M5	KPQT04-M5	KPGT04-M5	8	10.4	8	20.7	15.3	17	18	4	4	6
		—	—					22	21				
	1/4	KPQT04-02	KPGT04-02	14	—	26	25						
6	M5	KPQT06-M5	KPGT06-M5	8	12.8	10	22.8	15.8	18.5	19.5	10	10	7
		—	—					23.2	23.5				
	1/4	KPQT06-02	KPGT06-02	14	—	27.2	27.5						
8	M5	KPQT08-M5	KPGT08-M5	8	15.2	12	26.3	24.4	26	21.5	26	18	14
		—	—					28.4	30				
	1/4	KPQT08-02	KPGT08-02	14	—	29.9	33						
10	M5	KPQT10-M5	KPGT10-M5	8	18.5	17	29.4	29.9	33	24	41	29	29
		—	—					31.9	34.5				
	3/8	KPQT10-03	KPGT10-03	17	—	33.1	37						
12	M5	KPQT12-M5	KPGT12-M5	8	20.9	17	31.4	33.1	37	25	58	46	41
		—	—					37.1	39.5				
	1/2	KPQT12-04	KPGT12-04	22	—	37.1	39.5						

* Reference dimension for R threads after installation Note 1) øD₁ indicates the maximum diameter.

(M5)

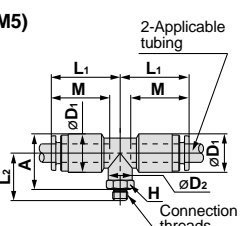

(R)

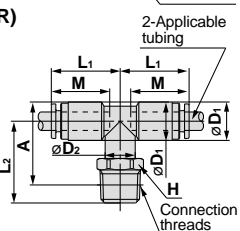

Dimensions (mm)

1in = 25.4mm, 1g = 0.0353oz

Male Run Tee: KPQY, KPGY

(M5)



Applicable tubing O.D. mm	Connection threads R	Model		H (width across flats)	Note 1) ϕD_1	ϕD_2	L1	L2	A*	M	Effective area mm ²		Weight g				
		TPH	TPS														
4	M5	KPQY04-M5	KPGY04-M5	8	10.4	8	15.3	32.5	18	4	4	6					
	1/8	KPQY04-01	KPGY04-01	10		10	20.7	22				36.5	13				
	1/4	KPQY04-02	KPGY04-02	14		10	26	40.5				19					
6	M5	KPQY06-M5	KPGY06-M5	8	12.8	8	15.8	35	19.5	10	10	7					
	1/8	KPQY06-01	KPGY06-01	10		10	22.8	23.2				40	14				
	1/4	KPQY06-02	KPGY06-02	14		10	27.2	44				20					
8	1/8	KPQY08-01	KPGY08-01	12	15.2	12	26.3	24.4	44.5	21.5	26	18	14				
	1/4	KPQY08-02	KPGY08-02	14		12	28.4	48.5	22								
	1/4	KPQY10-02	KPGY10-02	17		17	29.4	29.9	53.5				29				
10	3/8	KPQY10-03	KPGY10-03	17	18.5	17	29.4	31.9	55	24	41	29	39				
	1/2	KPQY12-03	KPGY12-03	22									20.9	31.4	33.1	58	41
	1/2	KPQY12-04	KPGY12-04	22									20.9	31.4	37.1	60.5	25

* Reference dimension for R threads after installation Note 1) ϕD_1 indicates the maximum diameter.

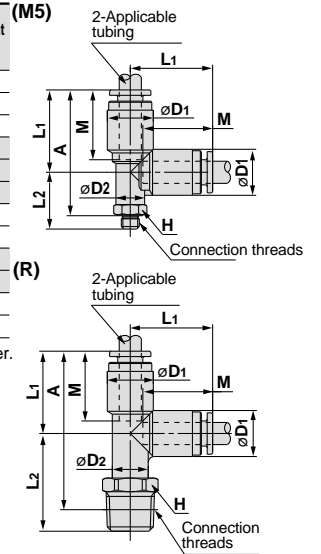

Male Branch: KPQU, KPGU

(M5)



Applicable tubing O.D. mm	Connection threads R	Model		H (width across flats)	Note 1) ϕD	L	P	A*	M	Effective area mm ²		Weight g
		TPH	TPS									
4	M5	KPQU04-M5	KPGU04-M5	11	10.4	41.7		38	18	4	4	10
	1/8	KPQU04-01	KPGU04-01	11		44.2	10.4	38				11
	1/4	KPQU04-02	KPGU04-02	14		48.2		42				20
6	M5	KPQU06-M5	KPGU06-M5	13	12.8	44.9		41.5	19.5	10	10	12
	1/8	KPQU06-01	KPGU06-01	13		47.4	12.8	41.5				11
	1/4	KPQU06-02	KPGU06-02	14		51.4		45.5				21
8	1/8	KPQU08-01	KPGU08-01	13	15.2	55.5		49.5	21.5	26	18	15
	1/4	KPQU08-02	KPGU08-02	17		60.6	15.2	54.5				23
	1/4	KPQU10-02	KPGU10-02	19		63.8		58				30
10	3/8	KPQU10-03	KPGU10-03	19	18.5	61.3	18.5	55	24	41	29	40
	1/2	KPQU12-03	KPGU12-03	22		67		60.5				40
	1/2	KPQU12-04	KPGU12-04	22		71.4	20.9	63.5				25

* Reference dimension for R threads after installation Note 1) ϕD indicates the maximum diameter.

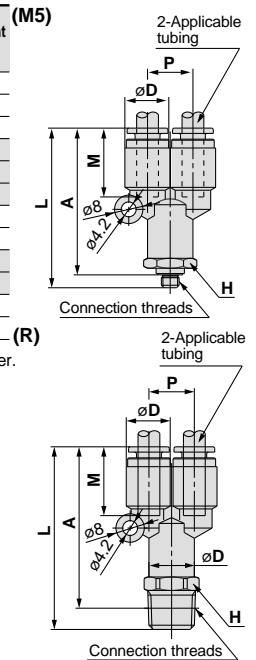

Straight Union: KPQH, KPGH



Applicable tubing O.D. mm	Model		Note 1) ϕD	L	M	Effective area mm ²		Weight g
	TPH	TPS						
4	KPQH04-00	KPGH04-00	10.4	37.4	18	4	4	4
6	KPQH06-00	KPGH06-00	12.8	39.6	19.5	10	10	6
8	KPQH08-00	KPGH08-00	15.2	44.4	21.5	26	18	10
10	KPQH10-00	KPGH10-00	18.5	48.6	24	41	29	15
12	KPQH12-00	KPGH12-00	20.9	50.6	25	58	46	18

Note 1) ϕD indicates the maximum diameter.

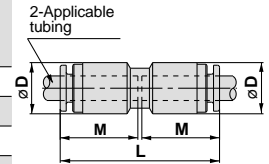

Dimensions (mm)

1in = 25.4mm, 1g = 0.0353oz

Elbow: KPQL, KPGL



Applicable tubing O.D. mm	Model		Note 1) ϕD	L	Q	M	Effective area mm ²		Weight g
							TPH	TPS	
4	KPQL04-00	KPGL04-00	10.4	20.7	4.5	18	3.5	3.5	3
6	KPQL06-00	KPGL06-00	12.8	22.8	5.3	19.5	9	9	7
8	KPQL08-00	KPGL08-00	15.2	26.3	6	21.5	22	15	11
10	KPQL10-00	KPGL10-00	18.5	29.4	6.8	24	35	25	16
12	KPQL12-00	KPGL12-00	20.9	31.4	7.5	25	50	40	20

Note 1) ϕD indicates the maximum diameter.

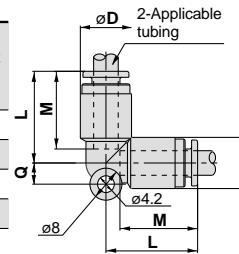

Union Tee: KPQT, KPGT



Applicable tubing O.D. mm	Model		Note 1) ϕD	L	Q	M	Effective area mm ²		Weight g
							TPH	TPS	
4	KPQT04-00	KPGT04-00	10.4	20.7	4.5	18	4	4	7
6	KPQT06-00	KPGT06-00	12.8	22.8	5.3	19.5	10	10	9
8	KPQT08-00	KPGT08-00	15.2	26.3	6	21.5	26	18	16
10	KPQT10-00	KPGT10-00	18.5	29.4	6.8	24	41	29	25
12	KPQT12-00	KPGT12-00	20.9	31.4	7.5	25	58	46	29

Note 1) ϕD indicates the maximum diameter.

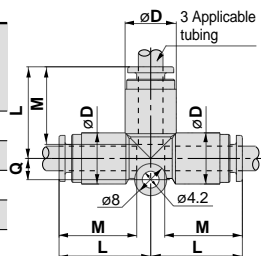

Union "Y": KPQU, KPGR



Applicable tubing O.D. mm	Model		Note 1) ϕD	L ₁	L ₂	P	Q	M	Effective area mm ²		Weight g
									TPH	TPS	
4	KPQU04-00	KPGR04-00	10.4	38.8	20.6	10.4	9.7	18	4	4	7
6	KPQU06-00	KPGR06-00	12.8	42.1	22.8	12.8	11.7	19.5	10	10	10
8	KPQU08-00	KPGR08-00	15.2	48.7	27.5	15.2	13.7	21.5	26	18	17
10	KPQU10-00	KPGR10-00	18.5	54	30.7	18.5	16.1	24	41	29	26
12	KPQU12-00	KPGR12-00	20.9	57.2	32.9	20.9	18.1	25	58	46	32

Note 1) ϕD indicates the maximum diameter.

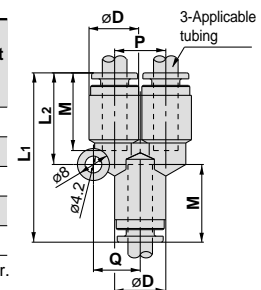

Plug-in Reducer: KPQR, KPGR



Applicable tubing O.D. mm	Applicable fitting size ϕd	Model		Note 1) ϕD	L	A	M	Effective area mm ²		Weight g
								TPH	TPS	
4	6	KPQR04-06	KPGR04-06	10.4	39.4	20.1	18	4	4	3
		KPQR04-08	KPGR04-08		41.9	20.2				
6	8	KPQR06-08	KPGR06-08	12.8	42.5	20.8	19.5	10	10	4
		KPQR06-10	KPGR06-10		45	21.2				
8	10	KPQR08-10	KPGR08-10	15.2	47	23.2	21.5	26	18	5
		KPQR08-12	KPGR08-12		48	23.2				
10	12	KPQR10-12	KPGR10-12	18.5	50.5	25.7	24	41	29	9

Note 1) ϕD indicates the maximum diameter.

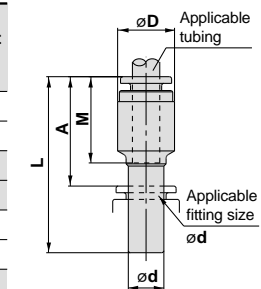

Plug: KPP



Applicable fitting size ϕd	Model	ϕD	L	A	Weight g
4	KPP-04	6	32	13.8	0.4
6	KPP-06	8	35	15.7	0.7
8	KPP-08	10	39	17.3	1.1
10	KPP-10	12	43	19.2	1.7
12	KPP-12	14	45.5	20.7	2.5

* The plug is common for series KPQ, KPG and KP.

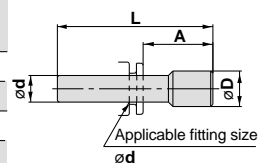



Series

● – 20m bundle □ – 100m bundle

Designation	TPH0425	TPH0604	TPH0806	TPH1075	TPH1209
O.D. mm	4	6	8	10	12
I.D. mm	2.5	4	6	7.5	9

White (W)	●	●	●	●	●
Black (B)	●	●	●	●	●
Red (R)	●	●	●	●	●
Blue (BU)	●	●	●	●	●
Yellow (Y)	●	●	●	●	●
Green (G)	●	●	●	●	●

Specifications

Fluid	Air, Nitrogen gas, Water (pure water) ^{Note 1)}				
Max. operating pressure at 20°C (68°F)	1.0MPa (145 psi) ^{Note 2)}		0.7MPa (101 psi) ^{Note 2)}		
Min. bending radius mm	15	25	35	45	55
Burst pressure	Refer to the burst pressure characteristics curve.				
Operating temperature	– 20 to 80°C (–4°F to 176°F), For water 5 to 80°C (41°F to 176°F)				
Material	Polyolefin resin				

Note 1) Consult SMC regarding other fluids. 1in = 25.4mm

Note 2) The maximum operating pressure is the value at 20°C (68°F). Refer to the burst pressure characteristics curve for other temperatures. Furthermore, an abnormal temperature rise due to adiabatic compression can cause tubing to burst.

Note 3) The minimum bending radius indicates the value at a temperature of 20°C (68°F) with an outside diameter rate of change of 10% or less. At higher temperatures the outside diameter rate of change may exceed 10% within the minimum bending radius.

Burst Pressure Characteristics Curve and Operating Pressure

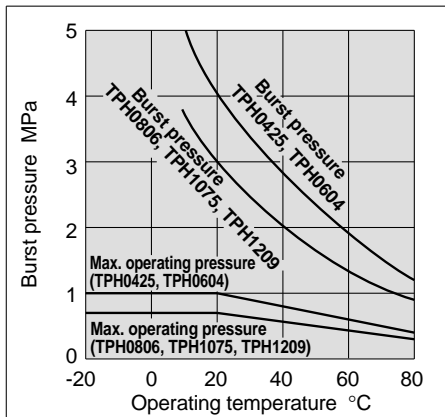

1MPa = 145 psi
 °F = (1.8 x °C) + 32°

How to Order

TPH0604 B 20

Tubing designation ●

Color ●

Symbol	Color
W	White
B	Black
R	Red
BU	Blue
Y	Yellow
G	Green

Roll length ●

Symbol	Length
20	20m bundle
100	100m bundle

1m = 3.28ft



Series

● -20m bundle □ -100m bundle

Designation	TPS0425	TPS0604	TPS0805	TPS1065	TPS1208
O.D. mm	4	6	8	10	12
I.D. mm	2.5	4	5	6.5	8

White (W)	●	□	●	□	●
Black (B)	●	□	●	□	●
Red (R)	●	□	●	□	●
Blue (BU)	●	□	●	□	●
Yellow (Y)	●	□	●	□	●
Green (G)	●	□	●	□	●

Specifications

Fluid	Air, Nitrogen gas, Water (pure water) ^{Note 1)}				
Maximum operating pressure at 20°C (68°F)	0.7MPa (101 psi) ^{Note 2)}				
Min. bending radius mm	10	20	25	30	40
Burst pressure	Refer to the burst pressure characteristics curve.				
Operating temperature	- 20 to 80°C (-40° to 176°F), For water 5 to 80°C (41° to 176°F)				
Material	Polyolefin resin				

Note 1) Consult SMC regarding other fluids.

1in = 25.4mm

Note 2) The maximum operating pressure is the value at 20°C (68°F). Refer to the burst pressure characteristics curve for other temperatures. Furthermore, an abnormal temperature rise due to adiabatic compression can cause tubing to burst.

Note 3) The minimum bending radius indicates the value at a temperature of 20°C (68°F) with an outside diameter rate of change of 10% or less. At higher temperatures the outside diameter rate of change may exceed 10% within the minimum bending radius.

Burst Pressure Characteristics Curve and Operating Pressure

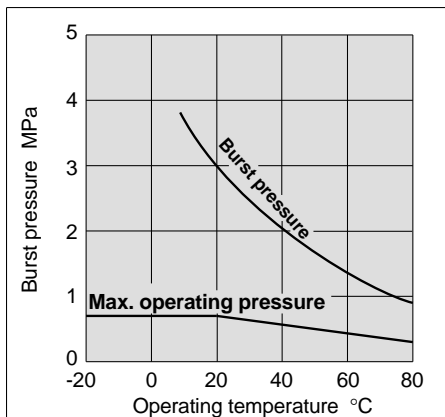

1MPa = 145 psi
 $^{\circ}\text{F} = (1.8 \times ^{\circ}\text{C}) + 32^{\circ}$

How to Order

TPS0604 B-20

Tubing designation Color Roll length

Symbol	Color
W	White
B	Black
R	Red
BU	Blue
Y	Yellow
G	Green

Symbol	Length
20	20m bundle
100	100m bundle

1m = 3.28ft

Polyurethane Tubing **Series 10-TU**

10 — TU0425 BU — 20

- Clean series
- Tubing designation
- Color

B	Black
W	White
R	Red
BU	Blue
Y	Yellow
G	Green
C	Clear
YR	Orange
- Roll length

20	20m bundle
1ft = 0.3048m	

Series

● – 20m bundle (~6ft)

Designation	Tubing size				
	Metric size (series TU)				
10-TU0425	10-TU0604	10-TU0805	10-TU1065	10-TU1208	
O.D. mm	4	6	8	10	12
I.D. mm	2.5	4	5	6.5	8

Black	●	●	●	●	●
White (W)	●	●	●	●	●
Red (R)	●	●	●	●	●
Blue (BU)	●	●	●	●	●
Yellow (Y)	●	●	●	●	●
Green (G)	●	●	●	●	●
Clear (C)	●	●	●	●	●
Orange (YR)	●	●	●	●	●

Specifications

Fluid	Air, Water				
Maximum operating pressure at 20°C (68°F)	0.8MPa (116 psi)				
Burst pressure	Refer to the burst pressure characteristics curve.				
Min. bending radius mm ^{Note)}	10	15	20	27	35
Operating temperature	Air: -20 to 60°C (-4° - 140°F), Water: 0 to 40°C (32° - 104°F) (w/no freezing)				
Material	Polyurethane				

Note) The minimum bending radius indicates the value at a temperature of 20°C (68°F) with an outside diameter rate of change of 10% or less. At higher temperatures the outside diameter rate of change may exceed 10% within the minimum bending radius.

Polyurethane Coiled Tubing **Series 10-TCU**



Specifications

Model	10-TCU 0425B-1	10-TCU 0425B-2	10-TCU 0425B-3	10-TCU 0604B-1	10-TCU 0604B-2	10-TCU 0604B-3	10-TCU 0805B-1
Number of cores	1 core	2 cores	3 cores	1 core	2 cores	3 cores	1 core
Tubing O.D. mm	4		6		8		
Tubing I.D. mm	2.5		4		5		
Fluid	Air						
Maximum operating pressure at 20°C (68°F)	0.8MPa (116 psi)						
Burst pressure	Refer to the burst pressure characteristics curve.						
Operating temperature	-20 to 60°C (-4° to 140°F)						
Material	Polyurethane						
Color	Black						

1in = 25.4mm

Polyurethane Flat Tubing **Series 10-TFU**



Specifications

Model	10-TFU 0425B-2	10-TFU 0425B-3	10-TFU 0604B-2	10-TFU 0604B-3	10-TFU 0805B-2	10-TFU 0805B-3
Number of cores	2 cores	3 cores	2 cores	3 cores	2 cores	3 cores
Tubing O.D. mm	4		6		8	
Tubing I.D. mm	2.5		4		5	
Fluid	Air					
Maximum operating pressure at 20°C (68°F)	0.8MPa (116 psi)					
Burst pressure	Refer to the burst pressure characteristics curve.					
Operating temperature	-20 to 60°C (-4° to 140°F)					
Material	Polyurethane					
Color	Black					
Min. bending radius mm	10		15		20	
Tubing roll length m	10					

1in = 25.4mm
1ft = 0.3048m

Air Operated Valve *Series LV*

Low particulate generating valve with excellent corrosion resistance

Series LVA



Series LVC



Threaded type/Series LVA (basic type)

Note 1) PFA body not available for LVA10

Series	Orifice size (mm)	Body material	Port size Rc				
			1/8	1/4	3/8	1/2	3/4
LVA10	ø2	Note 1) PFA PPS SUS316	●	●			
LVA20	ø4		○	●			
LVA30	ø8				○		
LVA40	ø12				○	●	
LVA50	ø20					○	●

○: Body material SUS316 only

Integral fitting type/Series LVC (basic type)

Series	Orifice size (mm)	Body material	Tubing size													
			Metric sizes					Inch sizes								
			4	6	8	10	12	19	1/8	3/16	1/4	3/8	1/2	3/4		
LVC20	ø4	PFA	●	●							●	●	●			
LVC30	ø8			●	●	●					●	●	●			
LVC40	ø10					●	●					●	●	●		
LVC50	ø16						●	●					●	●	●	●

Clean Regulator *Series SR*

Contamination controlled stainless steel regulator

Series SRH



Series SR



Series SRH

Series	Port size Rc						Liquid-contact part materials	
	1/8	1/4	3/8	1/2	9/16-18UNF	7/8-14UNF	Body	Diaphragm
SRH3000	●	●					SUS316L (fluid-contact parts SUS316)	Liquid-contact surfaces PTFE + Fluoro rubber (grade A) Fluoro rubber (grade B)
SRH4000		●	●	●		●		

Series SR

Series	Port size Rc					Liquid-contact part materials	
	M5	1/8	1/4	3/8	1/2	Body	Diaphragm
SR1000	●					SUS316	Fluoro rubber
SR3000		●	●				Fluoro rubber host with PTFE on liquid-contact surfaces
SR4000			●	●	●		

Clean Gas Filter *Series SF*

0.01mm particles 100% eliminated

Series SFA



Series SFB



Series SFC



Cartridge type

Series	Type	Principal materials			Thread type	Port size	
		Element	Housing	Seal		M5	1/4
100 SFA 200 300	Disk	PTFE + Polyethylene	SUS316 (electropolished)	Fluoro rubber (FPM)	Rc NPT		●
SFB100	Straight	PTFE membrane			TSJ UOJ	●	●

Disposable type

Series	Type	Principal materials			Thread type	Port size	
		Element	Housing	Seal		1/4	3/8
SFB300	Straight	PTFE membrane	SUS316 (electropolished)	—	Rc	●	
SFC100	Multistage Disk	PTFE membrane PVDF holder		O-ring PTFE	TSJ URJ	●	●

These safety instructions are intended to prevent a hazardous situation and/or equipment damage. These instructions indicate the level of potential hazard by a label of "**Caution**", "**Warning**" or "**Danger**". To ensure safety, be sure to observe ISO 4414 Note 1), JIS B 8370 Note 2) and other safety practices.

 **Caution** : Operator error could result in injury or equipment damage.

 **Warning** : Operator error could result in serious injury or loss of life.

 **Danger** : In extreme conditions, there is a possible result of serious injury or loss of life.

Note 1) ISO 4414: Pneumatic fluid power – Recommendations for the application of equipment to transmission and control systems

Note 2) JIS B 8370: General Rules for Pneumatic Equipment

 **Warning**

- 1. The compatibility of pneumatic equipment is the responsibility of the person who designs the pneumatic system or decides its specifications.**
 Since the products specified here are used in various operating conditions, their compatibility for the specific pneumatic system must be based on specifications or after analysis and/or tests to meet your specific requirements.
- 2. Only trained personnel should operate pneumatically operated machinery and equipment.**
 Compressed air can be dangerous if an operator is unfamiliar with it. Assembly, handling or repair of pneumatic systems should be performed by trained and experienced operators.
- 3. Do not service machinery/equipment or attempt to remove components until safety is confirmed.**
 1. Inspection and maintenance of machinery/equipment should only be performed after confirmation of safe locked-out control positions.
 2. When equipment is to be removed, confirm the safety process as mentioned above. Cut the supply pressure for this equipment and exhaust all residual compressed air in the system.
 3. Before machinery/equipment is restarted, take measures to prevent shooting-out of cylinder piston rod, etc. (Bleed air into the system gradually to create back pressure.)
- 4. Contact SMC if the product is to be used in any of the following conditions:**
 1. Conditions and environments beyond the given specifications, or if product is used outdoors.
 2. Installation on equipment in conjunction with atomic energy, railway, air navigation, vehicles, medical equipment, food and beverages, recreation equipment, emergency stop circuits, press applications, or safety equipment.
 3. An application which has the possibility of having negative effects on people, property, or animals, requiring special safety analysis.

Selection

Caution

1. Do not use in locations where the connecting threads and tubing connection will slide or rotate. The connecting threads and tubing connection will come apart under these conditions.
2. Use tubing at or above the minimum bending radius. Using below the minimum bending radius can cause breakage or flattening of the tube.
3. Consult SMC regarding fluids other than air, water and nitrogen gas.
4. In case of liquid fluids, keep surge pressure at or below the maximum operating pressure. If the surge pressure exceeds the maximum operating pressure, this can cause damage to the fittings and tubing.

Handling

Caution

1. Store away from direct sunlight at 40°C or less.
2. Open the inner package of double packaging in a clean room or other clean environment.

Mounting

Caution

1. Before mounting confirm the model and size, etc. Also, confirm that there are no blemishes, nicks or cracks in the product.
2. When tubing is connected, consider factors such as changes in the tubing length due to pressure, and allow sufficient leeway.
3. Mount so that fittings and tubing are not subjected to twisting, pulling or moment loads. This can cause damage to fittings and flattening, bursting or disconnection of tubing, etc.
4. Mount so that tubing is not damaged due to tangling and abrasion. This can cause flattening, bursting or disconnection of tubing, etc.

Installation of Threads

Be sure to wrap sealing tape around the taper threads for both resin and metal threads.

If used without sealing tape air leakage can occur.

1. Series KP (with resin threads)
 1. Wrapping of seal tape
Wrap the seal tape 2 to 3 times around the threads, leaving 1.5 to 2 thread ridges exposed at the end of the threads.
 2. Tightening
After tightening by hand, tighten an additional 2 to 3 turns using a tightening tool.

Installation of Threads

Caution

2. Series KPQ/KPG (with metal threads)
 1. For M5
After tightening by hand, tighten approximately 1/6 turn further using a tightening tool. Excessive tightening can cause air leakage due to thread damage or deformation of the gasket, etc. Insufficient tightening can cause loose threads and air leakage, etc.
 2. Taper threads
 - 1) Wrapping of seal tape
Wrap the seal tape 2 to 3 times around the threads, leaving 1.5 to 2 thread ridges exposed at the end of the threads.
 - 2) When installing, tighten with the proper torque shown in the table below. As a rule, this corresponds to two or three turns with a tool after tightening by hand.

Connection thread size	Proper tightening torque N·m
R 1/8	7 to 9
R 1/4	12 to 14
R 3/8	22 to 24
R 1/2	28 to 30

3. Tightening tools

Tighten with an appropriate wrench using the hexagon wrench flats on the body.

Position the wrench on the base as close as possible to the threads. If the size of the wrench is not suitable for the hexagon wrench flats, the wrench flats may be crushed.

Installation And Removal of Tubing

Caution

1. Installation of tubing
 - 1) Using tube cutters TK-1, 2 or 3, take a tube having no flaws on its periphery and cut it off at a right angle. Do not use pinchers, nippers or scissors, etc. The tubing might be cut diagonally or flattened, making installation impossible or causing problems such as disconnection and leakage.
 - 2) Hold the tube and push it in slowly, inserting it securely all the way into the fitting.
 - 3) After inserting the tubing, pull on it lightly to confirm that it will not come out. If it is not installed securely all the way into the fitting, problems such as leakage or disconnection of the tubing can occur.
 - 4) Grease is not used due to the series KP oil-free specifications. For this reason, greater insertion force is required when tubing is installed. In particular, polyurethane tubing may fold when inserted due to its softness. Hold the end of the tubing, and insert it all the way in slowly and securely. Refer to dimension "M" in the dimension drawings for guidance on the insertion depth of tubing.

Installation and Removal of Tubing

Caution

2. Removal of tubing
 - 1) Push in the release button sufficiently, pressing the collar evenly around its circumference.
 - 2) Pull out the tubing while holding down the release button so that it does not pop out. If the release button is not pressed down sufficiently, there will be increased bite on the tubing and it will become more difficult to pull it out.
 - 3) When the removed tubing is to be used again, first cut off the section of the tubing which has been chewed.
Using the chewed portion of the tube as it is can cause problems such as leakage or difficulty in removing the tubing.

Operating Environment

Warning

1. Do not use in environments or locations where there is a danger of damage to fittings and tubing.
For fitting and tubing materials, refer to specifications and construction drawings, etc.
2. Provide shade in locations which receive direct sunlight.
3. Do not operate in locations where vibration or impact occurs.
Since this can cause leakage and fitting damage, etc., contact SMC regarding use in this kind of environment.
4. Provide shielding in locations near heat sources.
When there are heat sources in the surrounding area, the product's temperature may rise due to radiated heat and exceed its operating temperature range. Block off the heat with a cover, etc.
5. Do not use in locations where static electric charges will be a problem. Consult SMC regarding use in this kind of environment.
6. Do not use in locations where spatter occurs.
There is a danger of spatter causing a fire. Consult SMC regarding use in this kind of environment.

Caution

1. Series KP are special One-touch fittings for use on **clean blowing** and **washing lines**. Consult SMC regarding other types of applications.
Seal material: The durability of EPDM with respect to mineral oils is inferior, making it unsuitable for piping in general pneumatic equipment.
Use series KPQ and KPG for piping to general pneumatic equipment.

Maintenance

Caution

1. Pre-maintenance inspection
When the product is to be removed, turn off the electric power, and be sure to cut off the supply pressure and confirm that fluid in the piping has been discharged.
2. Post maintenance inspection
After remounting and connection of piping, restore the fluid and electric power, and perform suitable function and leak tests. If leakage occurs or the equipment does not operate properly, stop operation immediately and confirm whether it is mounted correctly.
3. Tightening of blow fittings (resin taper threads for piping)
Since series KP taper threads are made of resin, minute leakage may gradually occur due to stress relaxation. Perform periodic inspections, and if leakage is detected correct the problem by further tightening. If additional tightening becomes ineffective, replace the fitting with a new product.
4. Check for the following during regular maintenance, and replace components as necessary.
 - a) Scratches, gouges, abrasion, corrosion
 - b) Leakage, refer to item 3 regarding taper thread leakage.
 - c) Twisting, flattening or distortion of tubing
 - d) Hardening, deterioration or softness of tubing
5. Do not repair or patch the replaced tubing or fittings for reuse.

Installation and Removal of Tubing

Caution

1. When using tubing brands other than SMC, confirm that the tubing outside diameter tolerances satisfy the following specifications.

1) Polyolefin tubing	±0.1mm
2) Polyurethane tubing	+0.15mm -0.2mm
3) Nylon tubing	±0.1mm
4) Soft nylon tubing	±0.1mm

Do not use tubing if the outside diameter tolerance is not satisfied. It may not be possible to connect the tubing, or leakage or disconnection may occur after connection.

Polyolefin tubing is recommended for use with clean room fittings. Note that while other types of tubing will satisfy performance standards for leakage and tubing pull-out strength, etc., the degree of cleanliness will deteriorate.

World Wide SMC Support...

North American Branch Offices For a branch office near you call: 1-800-SMC-SMC1 (762-7621)

SMC Pneumatics Inc. (Atlanta)
1440 Lakes Parkway, Suite 600
Lawrenceville, GA 30043
Tel: (770) 624-1940
FAX: (770) 624-1943

SMC Pneumatics Inc. (Detroit)
2990 Technology Drive
Rochester Hills, MI 48309
Tel: (248) 299-0202
FAX: (248) 293-3333

SMC Pneumatics Inc. (Rochester)
245 Summit Point Drive
Henrietta, NY 14467
Tel: (716) 321-1300
FAX: (716) 321-1865

SMC Pneumatics Inc. (Austin)
9101 Wall Street, Suite 1030
Austin, TX 78754
Tel: (512) 926-2646
FAX: (512) 926-7055

SMC Pneumatics Inc. (Houston)
9001 Jameel, Suite 180
Houston, TX 77040
Tel: (713) 460-0762
FAX: (713) 460-1510

SMC Pneumatics Inc. (S.F.)
85 Nicholson Lane
San Jose, CA 95134
Tel: (408) 943-9600
FAX: (408) 943-9111

SMC Pneumatics Inc. (Binghamton)
27 Link Drive
Binghamton, NY 13904
Tel: (607) 773-1300
Fax: (607) 773-8008

SMC Pneumatics Inc. (L.A.)
14191 Myford Road
Tustin, CA 92780
Tel: (714) 669-1701
FAX: (714) 669-1715

SMC Pneumatics Inc. (St. Louis)
4130 Rider Trail North
Earth City, MO 63045
Tel: (314) 209-0080
FAX: (314) 209-0085

SMC Pneumatics Inc. (Boston)
Zero Centennial Drive
Peabody, MA 01960
Tel: (978) 326-3600
Fax: (978) 326-3700

SMC Pneumatics Inc. (Milwaukee)
16850 W. Victor Road
New Berlin, WI 53151
Tel: (262) 827-0080
FAX: (262) 827-0092

SMC Pneumatics Inc. (Tampa)
8507-H Benjamin Road
Tampa, FL 33634
Tel: (813) 243-8350
FAX: (813) 243-8621

SMC Pneumatics Inc. (Charlotte)
5029-B West W.T. Harris Blvd.
Charlotte, NC 28269
Tel: (704) 597-9292
FAX: (704) 596-9561

SMC Pneumatics Inc. (Mnpls.)
990 Lone Oak Road, Suite 162
Eagan, MN 55121
Tel: (651) 688-3490
FAX: (651) 688-9013

SMC Pneumatics Inc. (Tulsa)
10203 A East 61st Street
Tulsa, OK 74146
Tel: (918) 252-7820
FAX: (918) 252-9511

SMC Pneumatics Inc. (Chicago)
27725 Diehl Road
Warrenville, IL 60555
Tel: (630) 393-0080
FAX: (630) 393-0084

SMC Pneumatics Inc. (Nashville)
5000 Linbar Drive, Suite 297
Nashville, TN 37211
Tel: (615) 331-0020
FAX: (615) 331-9950

SMC Pneumatics Inc. (Cincinnati)
4598 Olympic Blvd.
Erlanger, KY 41018
Tel: (859) 647-5600
FAX: (859) 647-5609

SMC Pneumatics Inc. (Newark)
3434 US Hwy. 22 West, Ste. 110
Somerville, NJ 08876
Tel: (908) 253-3241
FAX: (908) 253-3452

SMC Pneumatics Inc. (Cleveland)
2305 East Aurora Rd., Unit A-3
Twinsburg, OH 44087
Tel: (330) 963-2727
FAX: (330) 963-2730

SMC Pneumatics Inc. (Phoenix)
2001 W. Melinda Lane
Phoenix, AZ 85027
Tel: (623) 492-0908
FAX: (623) 492-9493

SMC Pneumatics Inc. (Columbus)
3687 Corporate Drive
Columbus, OH 43231
Tel: (614) 895-9765
FAX: (614) 895-9780

SMC Pneumatics Inc. (Portland)
14107 N.E. Airport Way
Portland, OR 97230
Tel: (503) 252-9299
FAX: (503) 252-9253

SMC Pneumatics Inc. (Dallas)
12801 N. Stemmons Frwy, Ste. 815
Dallas, TX 75234
Tel: (972) 406-0082
FAX: (972) 406-9904

SMC Pneumatics Inc. (Richmond)
5377 Glen Alden Drive
Richmond, VA 23231
Tel: (804) 222-2762
FAX: (804) 222-5221

Europe
ENGLAND
SMC Pneumatics (U.K.) Ltd.
GERMANY
SMC Pneumatik GmbH
ITALY
SMC Italia SpA
FRANCE
SMC Pneumatique SA
HOLLAND
SMC Controls BV
SWEDEN
SMC Pneumatics Sweden AB
SWITZERLAND
SMC Pneumatik AG
AUSTRIA
SMC Pneumatik GmbH
SPAIN
SMC España, S.A.
IRELAND
SMC Pneumatics (Ireland) Ltd.

SMC Thailand Ltd.
INDIA
SMC Pneumatics (India) Pvt., Ltd.
North America
CANADA
SMC Pneumatics (Canada) Ltd.
MEXICO
SMC Pneumatics (Mexico) S.A. de C.V.

South America
ARGENTINA
SMC Argentina S.A.
CHILE
SMC Pneumatics (Chile) Ltda.

Oceania
AUSTRALIA
SMC Pneumatics (Australia) Pty. Ltd.
NEW ZEALAND
SMC Pneumatics (N.Z.) Ltd.

Asia
JAPAN
SMC Corporation
KOREA
SMC Pneumatics Korea Co., Ltd.
CHINA
SMC (China) Co., Ltd.
HONG KONG
SMC Pneumatics (Hong Kong) Ltd.
SINGAPORE
SMC Pneumatics (S.E.A.) Pte. Ltd.
PHILIPPINES
SMC Pneumatics (Philippines), Inc.
MALAYSIA
SMC Pneumatics (S.E.A.) Sdn. Bhd.
TAIWAN
SMC Pneumatics (Taiwan) Co., Ltd.
THAILAND

SMC offers the same quality and engineering expertise in many other pneumatic components

Valves Directional Control Valves Manual Valves Mufflers Exhaust Cleaners Quick Exhaust Valves	Valves Proportional Valves Mechanical Valves Miniature Valves Fluid Valves	Cylinders/Actuators Compact Cylinders Miniature Cylinders Rodless Cylinders Rotary Actuators Pneumatic Grippers	Vacuum Vacuum Ejectors Vacuum Accessories Instrumentation Pneumatic Positioners Pneumatic Transducers	Air Preparation Equipment Filters-Regulators-Lubricators Coalescing Filters Micro Mist Separators Fittings Air Fittings
----------------------------------------------------------------------------------------------------------------------	-----------------------------------------------------------------------------------------------	---------------------------------------------------------------------------------------------------------------------------------------	------------------------------------------------------------------------------------------------------------------------------------	------------------------------------------------------------------------------------------------------------------------------------------------------

SMC Pneumatics Inc.

P.O. Box 26640, Indianapolis, IN 46226
Tel: (317) 899-4440 • FAX: (317) 899-3102