

Diaphragm Style Flow Switch

Series IFW5

The flow switch, series IFW is used for detection and confirmation of the flow as a relaying device for the general water applications in some various equipment such as cooling water fixture in the industrial machinery.

- **Low flow setting possible (1 ℓ/min)**
- **Simple flow setting**
Without removing the cover, you can set with a screwdriver from the outside.



PAT. PEND

How to Order

IFW5 10 N 03 1 1

Diaphragm style flow switch

Flow range

10	1 to 10 ℓ/min
20	10 to 20 ℓ/min
50	20 to 50 ℓ/min

Thread type

Nil	Rc
N	NPT
F	G

Port size

03	3/8
04	1/2
06	3/4

Light

0	None
1	With neon light (110 VAC, Red)
2	With neon light (110 VAC, Green)
3	With neon light (220 VAC, Red)
4	With neon light (220 VAC, Green)
5 ^{Note)}	With LED light (24 VDC, Red)
6 ^{Note)}	With LED light (24 VDC, Green)

Note) LED light is available for 5, 6, 7, 8 (with terminal box for 24 VDC).

Terminal box

0	Without terminal box (Contact: 1ab)
1	With terminal box (Contact: 1ab)
2	With terminal box (Contact: 1b)
5 ^{Note)}	With terminal box (24 VDC, ⊕COM, Contact: 1b)
6 ^{Note)}	With terminal box (24 VDC, ⊕COM, Contact: 1a)
7 ^{Note)}	With terminal box (24 VDC, ⊖COM, Contact: 1b)
8 ^{Note)}	With terminal box (24 VDC, ⊖COM, Contact: 1a)

Note) Terminal box for 24 VDC is available for 5, 6 (LED light).

Specifications

Fluid	Water/Non-corrosive liquid *	
Operating pressure	0.1 to 0.6 MPa	
Water resistance	1.2 MPa	
Operating temperature range	-5 to 60°C (No freezing)	
Operation	Diaphragm style	
Insulation resistance	100 MΩ (500 DC by megameter)	
Withstand voltage	1500 VAC for one min.	
Contact	Without terminal box: 1ab	
	With terminal box: 1a or 1b	
Port size	3/8, 1/2, 3/4	
Body material in contact with fluid material	Body	BC6
	Rod	C3604B
	Diaphragm	NBR

About the use of *, please confirm SMC.

ZSE
ISE

PSE

ZSE3

PS

ZSE1

ZSE2

ZSP

ISA2

IS

ZSM

PF2

IF

Data

Series IFW5

Micro Switch Ratings

Voltage	Non inductive load (A)				Inductive load (A)			
	Load resistance		Light load		Inductive load		Motor load	
	N.C.	N.O.	N.C.	N.O.	N.C.	N.O.	N.C.	N.O.
125 VAC	5	5	1.5	0.7	4	4	2.5	1.3
250 VAC	5	5	1	0.5	4	4	1.5	0.8
8 VDC	7	5	3	3	5	4	3	3
14 VDC	5	5	3	3	4	4	3	3
30 VDC	5	5	3	3	4	4	3	3
125 VDC	0.4	0.4	0.1	0.1	0.4	0.4	0.1	0.1
250 VDC	0.3	0.3	0.05	0.05	0.3	0.3	0.05	0.05

Model

Model	Flow range (l/min)	Max. flow (l/min)	Hysteresis (l/min) ^{Note)}
IFW510	1 to 10	20	1 or less
IFW520	10 to 20	25	1.5 or less
IFW550	20 to 50	60	3 or less

Note) Hysteresis is the flow rate that is necessary for moving the microswitch from the operation position (ON signal) to the return position (OFF signal).

Construction/Working Principle

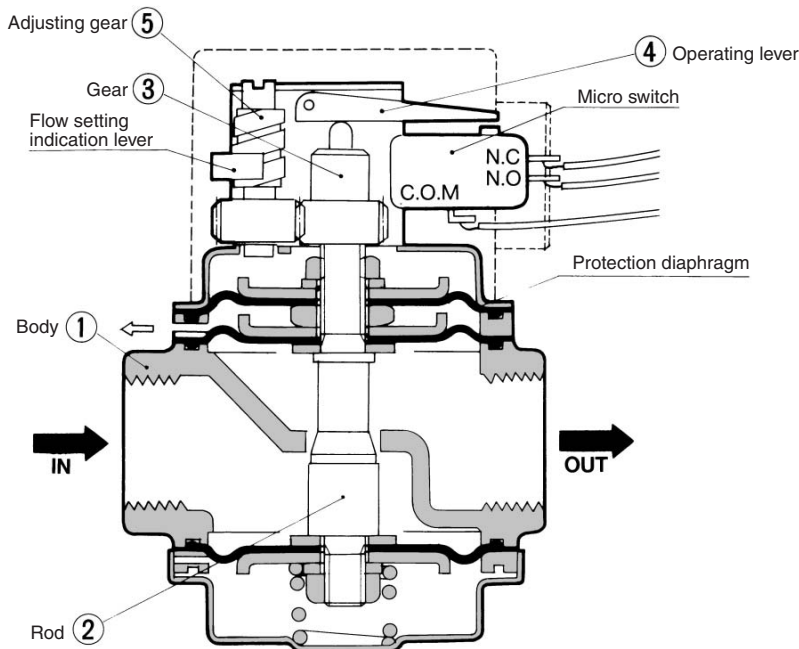

Working Principle

Liquid flow creates a pressure differential nearby the orifice of the port of the body ①. One set of diaphragms monitors the pressure differential and operates the micro switch through the rod ② and operating lever ④.

The rod ② moves downward with increased flow, and upward with decreased flow. Moving the gear ⑤ upward or downward by the adjusting gear ③ manually offers an electric signal at various flow rates.

Component Parts

No.	Description	Material
①	Body	BC6
②	Rod	C3604B
③	Gear	POM

No.	Description	Material
④	Operating lever	SPCC
⑤	Adjusting gear	POM

Flow Characteristics

IFW510

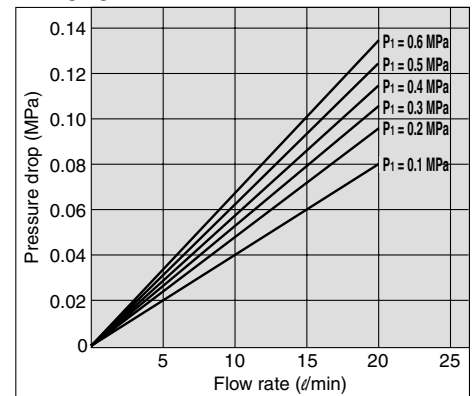

IFW520

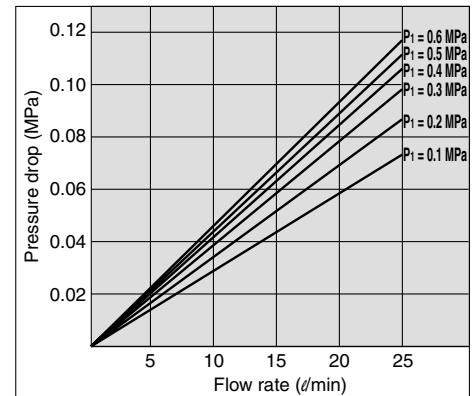

IFW550

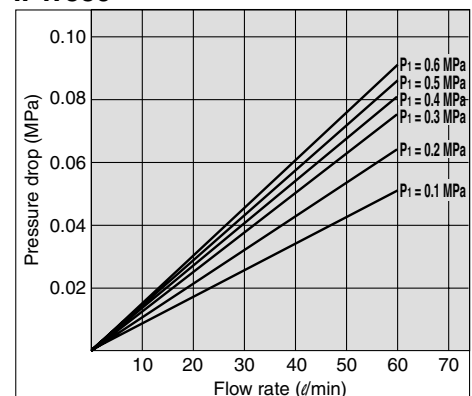

Diaphragm Style Flow Switch Series IFW5

Dimensions

IFW5□0-□□-00 to 04
(Without terminal box)

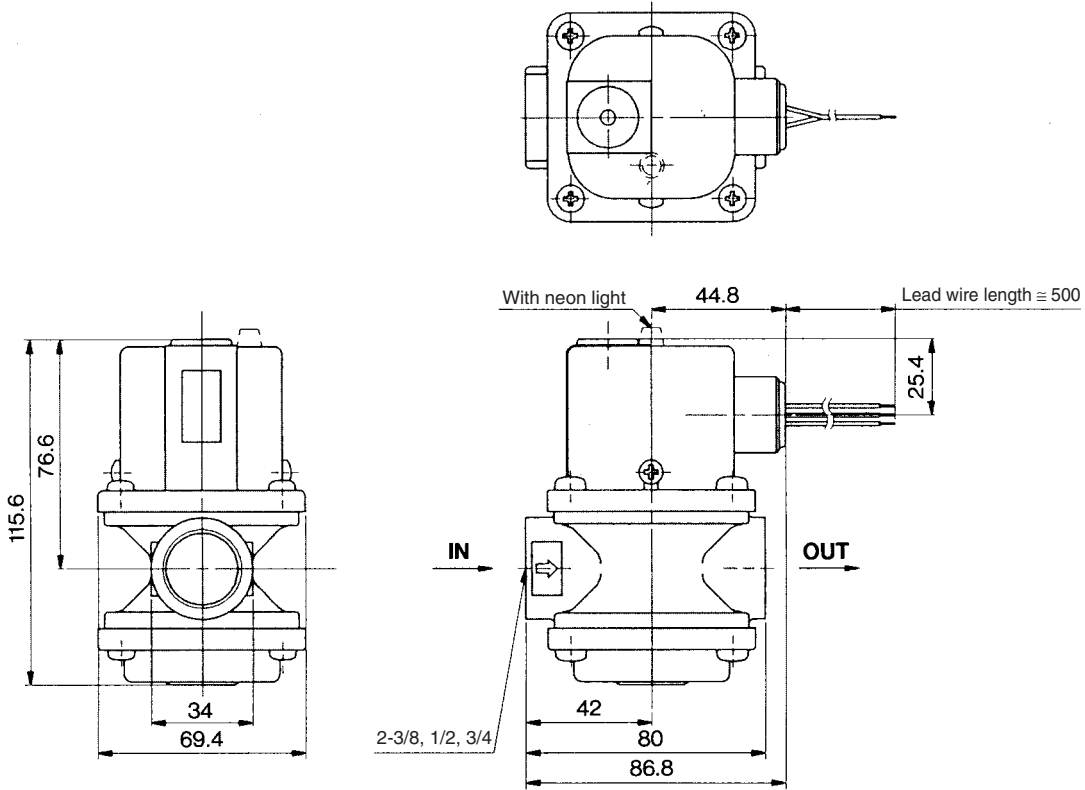

IFW5□0-□□-10 to 24
(With terminal box)

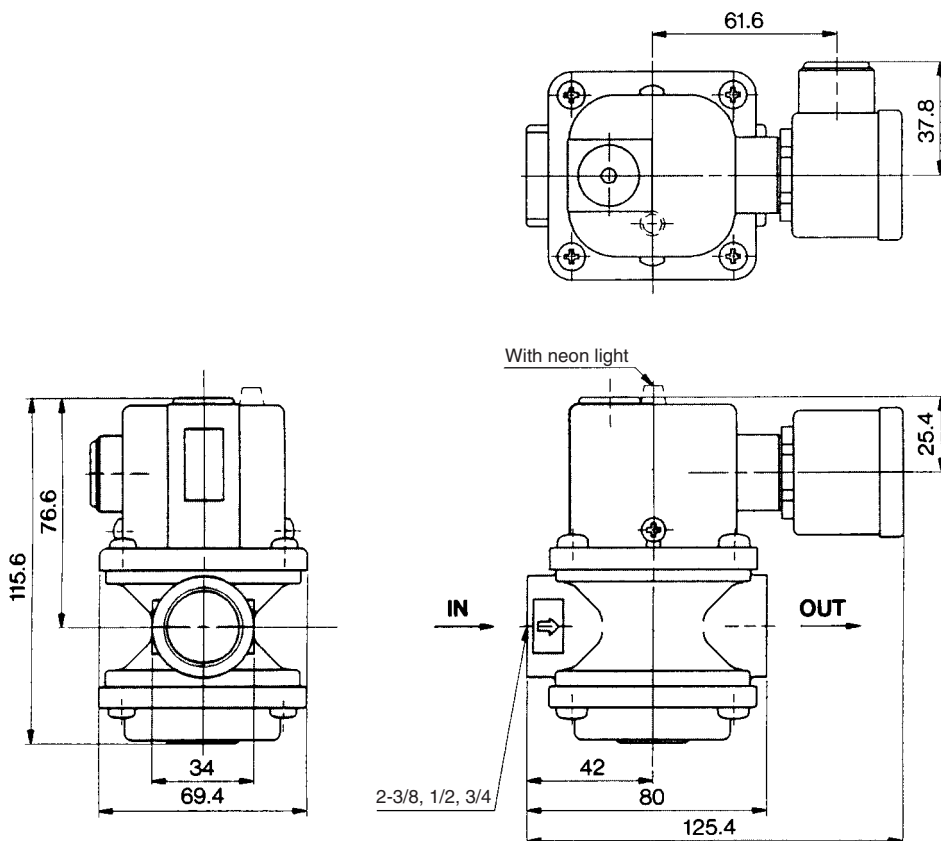

ZSE□
ISE□
PSE
ZSE3
PS
ZSE ₁ ²
ZSP
ISA2
IS□
ZSM
PF2□
IF□
Data

Series IFW5

IFW5□0-□□-55 to 86
(With light, Terminal box for 24 VDC)

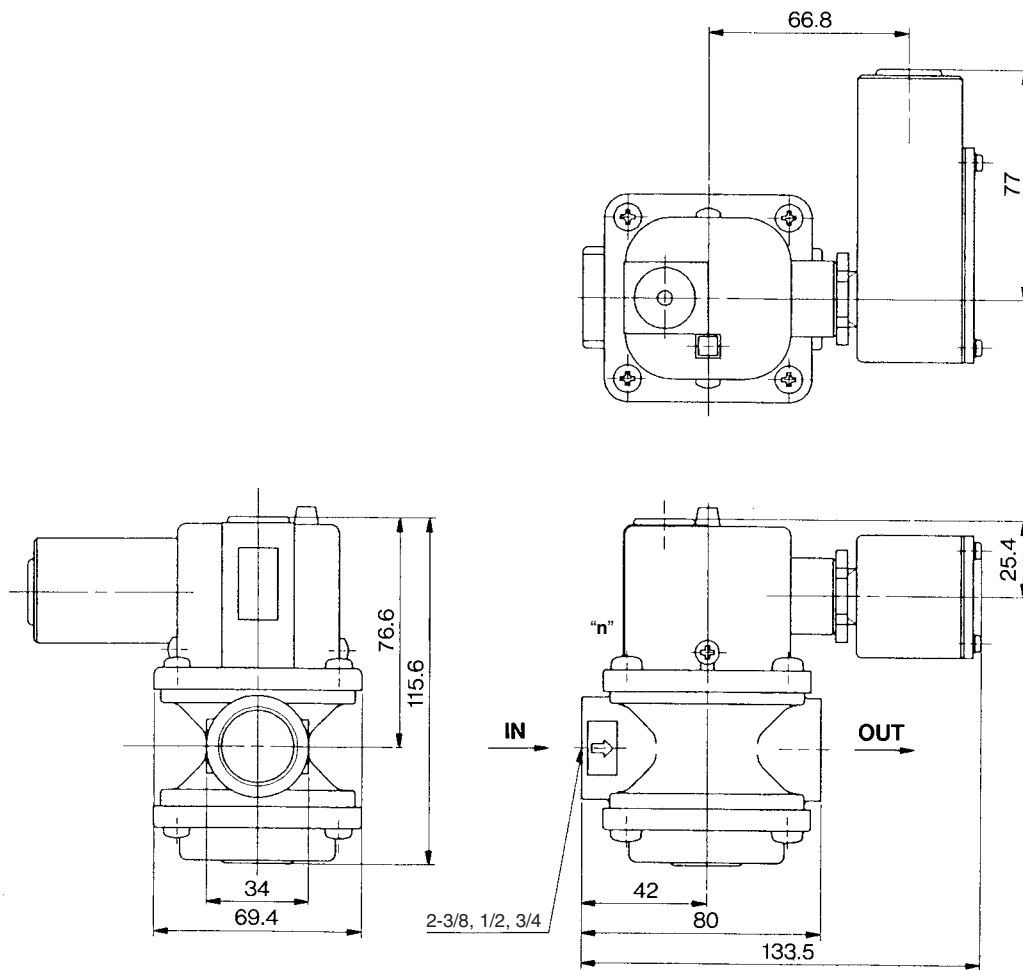

Diaphragm Style Flow Switch Series IFW5

Internal Wiring Diagram

IFW5□0-□□-00/10/20

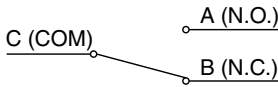

Symbol	Contact	Color of lead wire
C	Common	Black
A	Normally Open	White
B	Normally Closed	Red

IFW5□0-□□-01 to 04/11 to 14/21 to 24

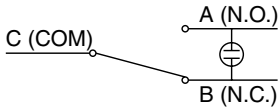

Symbol	Contact	Color of lead wire
C	Common	Black
A	Normally Open	White
B	Normally Closed	Red

IFW5□0-□□-55/56

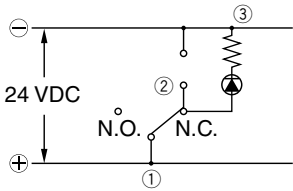

Symbol	Contact	Color of lead wire
①	Power supply (Common)	Black
②	Terminal (Relay terminal)	Red
③	Power supply (Light terminal)	Blue

IFW5□0-□□-65/66

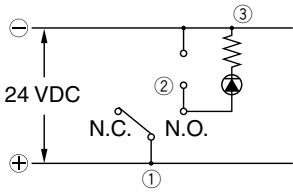

Symbol	Contact	Color of lead wire
①	Power supply (Common)	Black
②	Terminal (Relay terminal)	White
③	Power supply (Light terminal)	Blue

IFW5□0-□□-75/76

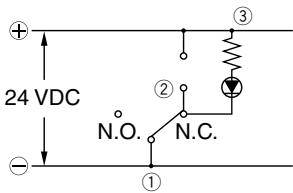

Symbol	Contact	Color of lead wire
①	Power supply (Common)	Black
②	Terminal (Relay terminal)	Red
③	Power supply (Light terminal)	Gray

IFW5□0-□□-85/86

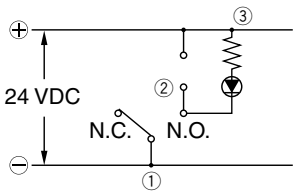

Symbol	Contact	Color of lead wire
①	Power supply (Common)	Black
②	Terminal (Relay terminal)	White
③	Power supply (Light terminal)	Gray

⚠ Precautions

Be sure to read before handling. Refer to pages 16-14-13 to 16-14-4 for Safety Instructions and Common Precautions on the products mentioned in this catalog, and refer to pages 16-1-11 to 16-1-13 for Precautions on every series.

Mounting & Wiring

⚠ Caution

1. Mount a switch, so that the liquid flow is in the same direction as that of the arrow on the body.
2. The flow switch can be installed either horizontally or vertically.
3. Provide a straight pipe portion that corresponds to approximately 5 times the bore of the pipe before and after the area of the pipe on which the product is installed, thus keeping the product as far away as possible from the elements that disturb the flow, such as elbows or valves.
4. For wiring, refer to the internal wiring diagram.
5. If a terminal box is not available, wire by selecting the contact at 1a or 1b. At that time, insulate the lead wires that will not be used.
6. Because this is an open style, it cannot be used where water or oil splashes.
7. It cannot be used if a water hammer or pulsation pressure is applied to the fluid.
8. In order to prevent a malfunction or diaphragm damage caused by debris or cutting chips in the fluid, install a filter with approximately 100 mesh on the inlet side of a flow switch.

Adjusting

⚠ Caution

1. To adjust flow, remove grommet of the upper cover and rotate flow adjusting gear using a flat head screwdriver. Turning clockwise can increase the set flow and turning counterclockwise can decrease the set flow.
2. Align the indicator needle to the graduation on the left side of the window name plate if the IN side pressure is 0.1 MPa, and to the graduation on the right side if the pressure is 0.2 MPa. (Refer to Fig. (1).)
3. The flow rate setting point is set at the ON flow rate. Therefore, in the case of the 1a contact, the ON signal is output if fluid with a higher flow rate than the set flow rate has occurred. In the case of the 1b contact, the OFF signal is output when the flow rate has decreased from the set flow rate for the amount that corresponds to the hysteresis.
4. If the IN side pressure exceeds 0.2 MPa, the setting cannot be made with the graduation on the window name plate. Therefore, perform the setting by installing a flow rate gauge on the outlet side of the flow switch.
5. To prevent the chattering that is associated with the fluctuation of the operating flow rate, set the difference between the set flow rate and the operating flow rate so that it is as large as possible.
6. Use at or below the maximum operating pressure and maximum flow rate.

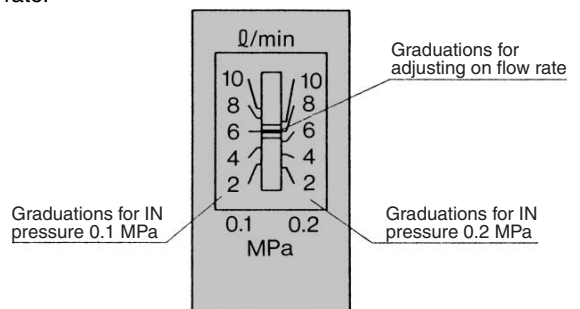

Fig. (1) Viewing faceplate

ZSE□
ISE□

PSE

ZSE3
I

PS

ZSE1
I

ZSP

ISA2

IS□

ZSM

PF2□

IF□

Data