

# Process Valve: 2 Port Valve For Compressed Air and Air-hydro Circuit Control

## Series VNA

Exclusively for air pressure system and air-hydro circuit control  
**Universal 2 Port Valve**

Cylinder actuation by external pilot air

The balance poppet permits normal and reverse flow.

Operation from 0 MPa is possible. Wide variations is possible.

N.C., N.O., C.O., types are available. Threaded type from 6A to 50A is standardized.

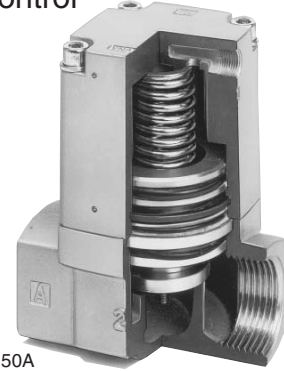

### Compressed Air

Air pressure circuit: Application examples

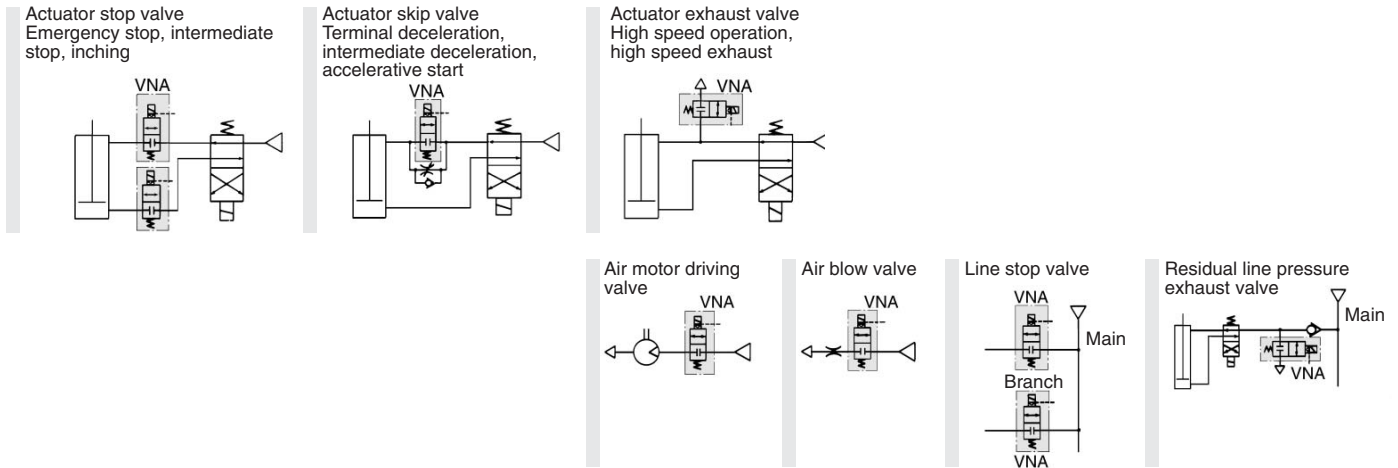

### Air-hydro

#### Operation Capacity When Used in Air-hydro Units

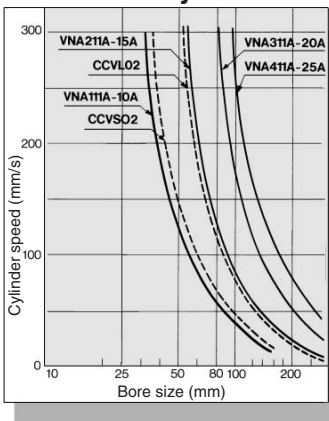

This series can supplement the capacity of conventional air-hydro valve units. They are suited to operate large bore cylinders as well as to simultaneously operate multiple cylinders and suspend their operation. Thus they can be used in the same way as the conventional air-hydro units.

#### Air-hydro circuit: Application example Basic circuit

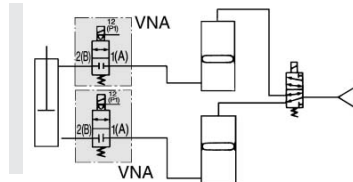

Conditions

Supply pressure	0.49 MPa
Hydraulic fluid	ISO VG32
Load	No load
Piping length	1 m

Piping diameter	Model	Piping length
3/8B (9 mm)	VNA111A, CCVSD2	
1/2B (13 mm)	VNA211A, CCVL02	
3/4B (19 mm)	VNA311A	
1B (25 mm)	VNA411A	

Refer to Air-hydro Unit pages in "Best Pneumatics Vol. 10" for further information on air-hydro.

#### Caution

##### When speed controller is mounted

Connect a speed controller (Series AS etc.) to A port (cast in body A) of VNA□11 (in order to protect the speed control valve from surges when cylinder operation is suspended, thus improving stopping accuracy).

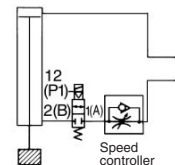
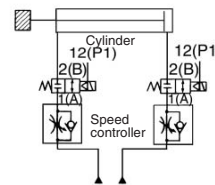

#### Caution

##### Skip valve function

Combination of 2 or more valves of Series VNA provides a skip valve function. Connect the skip valve to the A port side of a stop valve as in the case of the speed control valve.

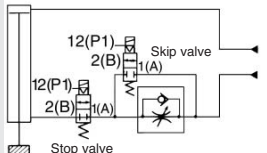
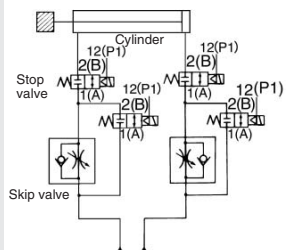

VC□

VDW

VQ

VX2

VX□

VX3

VXA

VN□

LVC

LVA

LVH

LVD

LVQ

LQ

LVN

TI/  
TIL

PA

PAX

PB

# Series VNA

## How to Order

**Seal material**  

A	NBR seals
B	FKM seals
C	EPR seals

Refer to "Table (1)" for availability.

**Thread type**  

Nil	Rc
F	G
N	NPT
T	NPTF

**Bracket (Valve size: 1/2/3/4.)**  

Nil	None
B	With bracket (VN□-16) *□:Valve size

Note 1) Valve size 1 comes with NV1-A16 (with thread).  
Note 2) Shipped after assembled at our factory.

**Air operated**

**VNA 2 0 1 A □ □ 15A □ □**

**External pilot solenoid**

**VNA 2 1 1 A □ □ 15A 1 T □ □**

**Valve size**

Symbol	Orifice size (mm)	Symbol			Symbol	Port size Rc
		1	2	3 Note)		
1	ø10	●	●	●	6A	1/8
		●	●	●	8A	1/4
		●	●	●	10A	3/8
2	ø15	●	●	●	10A	3/8
		●	●	●	15A	1/2
3	ø20	●	●	●	20A	3/4
4	ø25	●	●	●	25A	1
5	ø32	●	●	●	32A	1 1/4
6	ø40	●	●	●	40A	1 1/2
7	ø50	●	●	●	50A	2

**Rated voltage**

1	100 VAC 50/60 Hz
2	200 VAC 50/60 Hz
3*	110 VAC 50/60 Hz
4*	220 VAC 50/60 Hz
5	24 VDC
6*	12 VDC
7*	240 VAC 50/60 Hz
9*	Other

\* Option

**Manual override**

Nil: Non-locking push type

A: Non-locking extended type

B: Locking slotted type

Nil: Non-locking push type

Valve size 1 to 4

Valve size 5 to 7

Note) Air operated only

**Table (1) Applicable Fluids**

Model	VNA□□□A (Valve material: NBR seal)	VNA□□□B (Valve material: FKM seal)	VNA□□□C (Valve material: EPR seal)
Fluid	Air (Standard, Dry) Carbon dioxide (CO <sub>2</sub> ) (0.7 MPa Max.) Nitrogen gas (N <sub>2</sub> ) Freon® 11, 113, 114, Turbine oil (40 to ) Hydraulic fluid (100 cst)	Argon Helium Turbine oil (99°C) Hydraulic fluid	Carbon dioxide (CO <sub>2</sub> ) (0.7 MPa max.)

**Caution**

Please contact SMC for other fluids, operating conditions, etc.

**Electrical entry/  
With light/surge voltage suppressor**

G	Grommet	Valve size 1 to 4
GS	Grommet with surge voltage suppressor	
E	Grommet terminal	
EZ	Grommet terminal with light/surge voltage suppressor	
T	Conduit terminal	Valve ** size 5 to 7
TZ	Conduit terminal with light/surge voltage suppressor	
D	DIN terminal	
DZ	DIN terminal with light/surge voltage suppressor	
G	Grommet	
GS	Grommet with surge voltage suppressor	
C	Conduit	
T	Conduit terminal	
TS	Conduit terminal with surge voltage suppressor	
TZ*	Conduit terminal with light/surge voltage suppressor	
TL**	Conduit terminal with indicator light	
D	DIN terminal	
DL	DIN terminal with indicator light	

\* Except rated voltage 6, 7, 9.  
\*\* DZ: For DIN terminal with light/surge suppressor protection circuit, add suffix -X200 to the end of the part number. In this case, pilot solenoid valve is VO307-□DZ.

# Process Valve: 2 Port Valve For Compressed Air and Air-hydro Circuit Control **Series VNA**

## Model

Model	Port size Rc	Orifice size $\phi$ (mm)	Flow characteristics				Weight (kg)	
			Measured by air		Measured by water <sup>Note)</sup>		Air operated	External pilot solenoid
			C [dm <sup>3</sup> / (bar·sec) ]	b	Cv	Av x 10 <sup>-5</sup> m <sup>2</sup>		
VNA1□□□-6A	1/8	10	3.5	0.35	0.88	25	0.1	0.2
VNA1□□□-8A	1/4		5.9	0.24	1.5	41		
VNA1□□□-10A	3/8		7.9	0.16	1.9	51		
VNA2□□□-10A	1/2	15	16	0.35	3.8	110	0.3	0.4
VNA2□□□-15A			23	0.25	4.8	130		
VNA3□□□-20A	3/4	20	34	0.16	7.5	210	0.5	0.6

Note) This product cannot be used for water application.

Model	Port size Rc	Orifice size $\phi$ (mm)	Flow characteristics		Weight (kg)	
			Cv	Effective area (mm) <sup>2</sup>	Air operated	External pilot solenoid
VNA4□□□-25A	1	25	12	220	0.8	0.9
VNA5□□□-32A	1 1/4	32	18	320	1.3	1.4
VNA6□□□-40A	1 1/2	40	28	500	2.1	2.2
VNA7□□□-50A	2	50	43	770	3.1	3.2



## Valve Specifications

Fluid	Refer to "Table (1)" on page 17-4-6.	
Fluid temperature	VNA□□□ A	-5 to 60°C <sup>(1)</sup>
	VNA□□□ B	-5 to 99°C <sup>(1)</sup>
	□□□ C	(Air operated type only)
Ambient temperature	-5 to 50°C <sup>(1)</sup> (Air operated type: 60°C)	
Proof pressure	1.5 MPa	
Operating pressure range	0 to 1 MPa	
External pilot air	Pressure range	0.2 to 0.7 MPa
	Lubrication	Not required (Use turbine oil Class 1 ISO VG32, if lubricated. <sup>(2)</sup> )
	Temperature	-5 to 50°C <sup>(1)</sup> (Air operated type: 60°C)



Note 1) No freezing

Note 2) Lubrication is not allowed for use with EPR seal

## Pilot Solenoid Valve Specifications

Port size	6A to 25A		32A to 50A
Pilot solenoid valve	SF4-□□□-23		VO301-00□□□
Electrical entry	Grommet, Grommet terminal		Grommet, Conduit
	Conduit terminal		DIN terminal
	DIN terminal		Other (Option)
Coil rated voltage (V)	AC (50/60 Hz)	100 V, 200 V, Other voltage (Option)	
	DC	24 V, Other voltage (Option)	
Allowable voltage fluctuation	-15% to +10% of rated voltage		
Coil insulation type	Class B or equivalent (130°C)		
Temperature rise	35°C or less		70°C or less
	(When rated voltage is applied.)		(When rated voltage is applied.)
Apparent power	AC	Inrush	5.6 VA (50 Hz), 5.0 VA (60 Hz)
		Holding	3.4 VA (50 Hz), 2.3 VA (60 Hz)
Power consumption	DC	1.8 W	
		4.8 W	
Manual override	Non-locking push type		Non-locking push type
	Other (Option)		

## JIS Symbol

Style	Valve type	N.C.	N.O.	C.O.
		Normally closed	Normally open	Double acting
Air operated		VNA□01	VNA□02	VNA□03
External pilot solenoid		VNA□11	VNA□12	

VC□

VDW

VQ

VX2

VX□

VX3

VXA

VN□

LVC

LVA

LVH

LVD

LVQ

LQ

LVN

TI/  
TIL

PA

PAX

PB

# Series VNA

**Port size 6A, 8A, 10A**

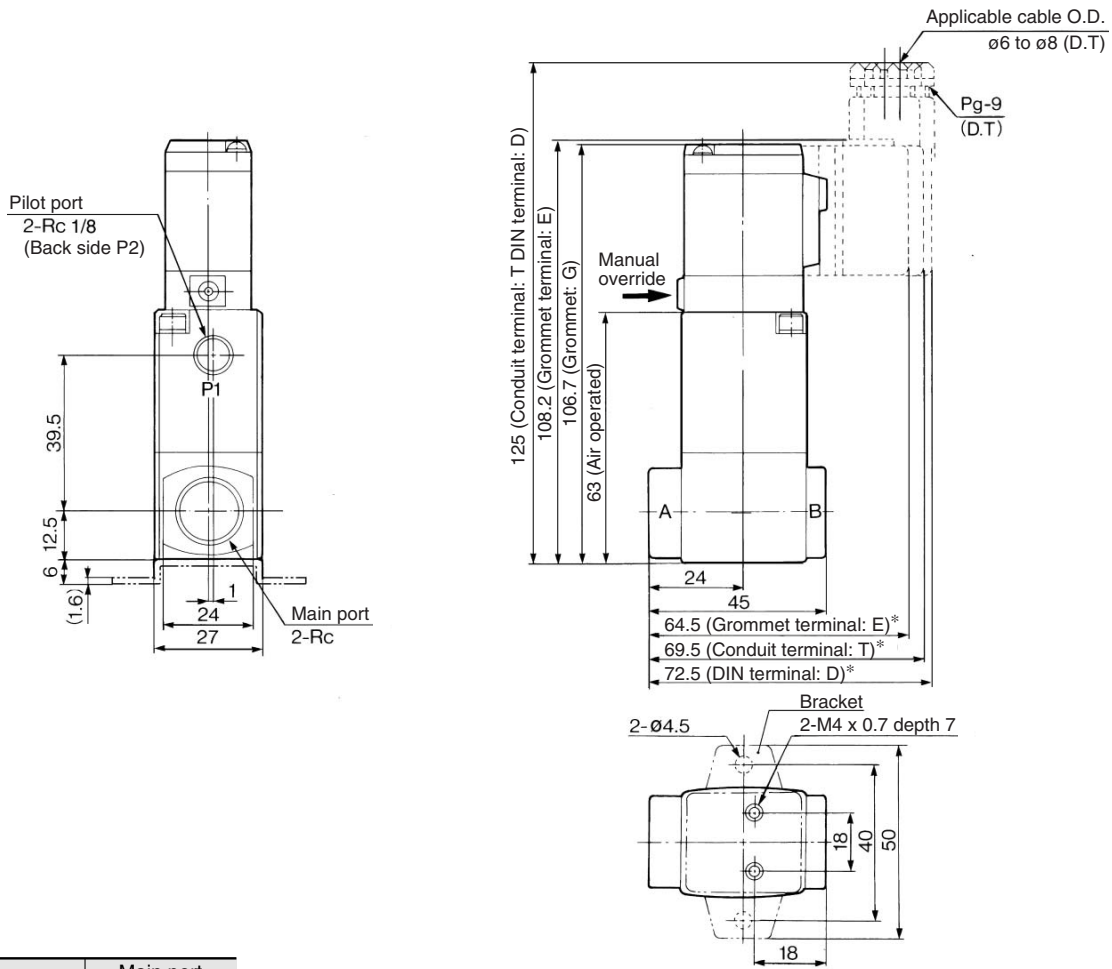

Model	Main port Rc
VNA1□□□-6A	1/8
VNA1□□□-8A	1/4
VNA1□□□-10A	3/8

\* In the case of "EZ" or "TZ", the length is longer by 10 mm.  
For "DZ", the length is longer by 17 mm.

## Process Valve: 2 Port Valve For Compressed Air and Air-hydro Circuit Control **Series VNA**

### Port size    10A, 15A, 20A, 25A

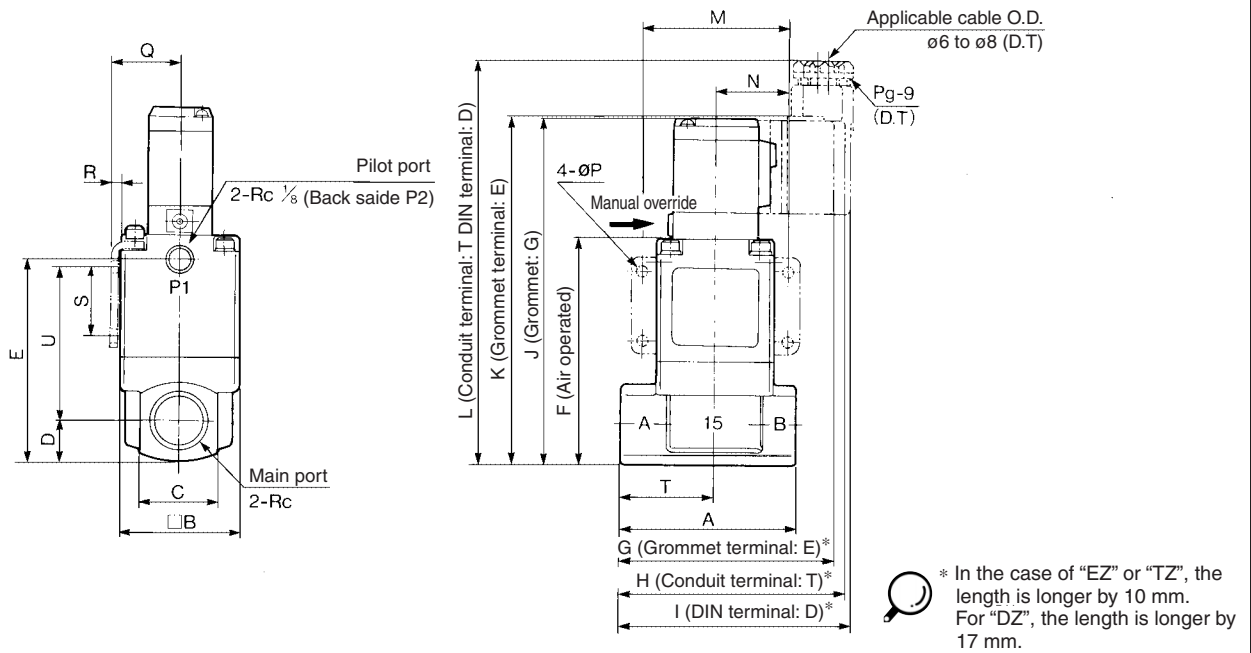

Model	Main port Rc	A	B	C	D	E	F	G	H	I	J	K	L	M	N	P	Q	R	S	T	U
VNA2□□□-10A	3/8	63	42	28	14	72.5	80.5	74.5	79.5	82.5	124	125.5	142.5	52	26	4.5	24.3	2.3	25	34	55
VNA2□□□-15A	1/2	63	42	28	14	72.5	80.5	74.5	79.5	82.5	124	125.5	142.5	52	26	4.5	24.3	2.3	25	34	55
VNA3□□□-20A	3/4	80	50	35	17.5	84	92	83.5	88.5	91.5	135.5	137	154	62	31	5.5	28.3	2.3	30	43	60.5
VNA4□□□-25A	1	90	60	40	20	100	108	89.5	94.5	97.5	151.5	153	170	72	36	6.5	33.3	2.3	35	49	73

### Port size    32A, 40A, 50A

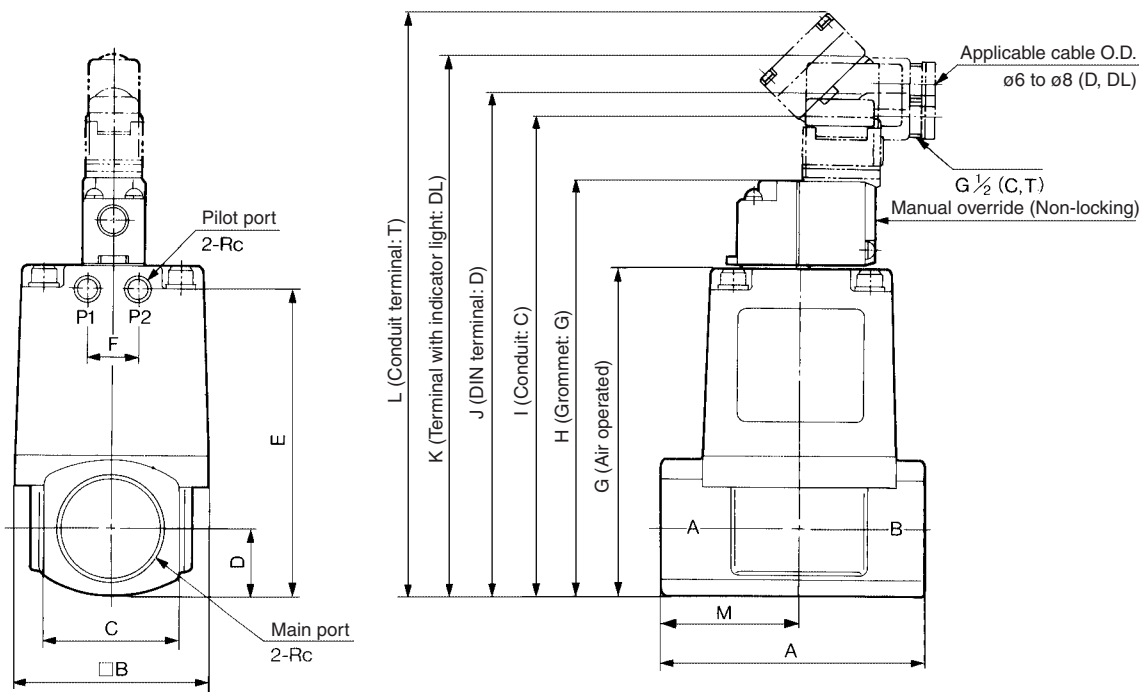

Model	Main port Rc	Pilot port Rc	A	B	C	D	E	F	G	H	I	J	K	L	M
VNA5□□□-32A	1 1/4	1/8	105	77	53	26.5	120.5	20	129.5	163	175.5	219.5	222.5	229.5	55
VNA6□□□-40A	1 1/2	1/4	120	96	60	30	137	24	147	180.5	193	237	240	247	63
VNA7□□□-50A	2	1/4	140	113	74	37	160	24	170	203.5	216	260	263	270	74

- VC
- VDW
- VQ
- VX2
- VX
- VX3
- VXA
- VNO
- LVC
- LVA
- LVH
- LVD
- LVQ
- LQ
- LVN
- TI/TIL
- PA
- PAX
- PB

# Series VNA

## ⚠ Precautions

Be sure to read before handling. Refer to page 17-6-3 for Safety Instructions and Solenoid Valve Precautions.

### External Pilot

#### ⚠ Caution

##### 1. Pilot port piping

12(P1) and 10(P2) piping should be as follows according to the model

Port	VNA□01□	VNA□02□	VNA□03□	VNA□1 $\frac{1}{2}$ □
12 (P1)	External pilot	Bleed port	External pilot	External pilot
10 (P2)	Bleed port	External pilot	External pilot	Pilot exhaust

Installing a silencer to the exhaust port and the bleed port is recommended for noise reduction and for dust entry prevention.

### Piping

#### ⚠ Caution

When high temperature fluids are used, use fittings and tubing with heat resistant features.

(Self-align fittings, Teflon® tubing, Copper tubing, etc.)

### Mounting Direction of Pilot Solenoid Valve

#### ⚠ Caution

When replacing a valve, if an external pilot solenoid valve is mounted in the wrong direction, it may malfunction or leak air.

### Use with Air-hydro Unit

#### ⚠ Warning

##### 1. Piping

Surge pressure is generated between the cylinder and the VNA during intermediate stoppage.

To directly thread in the cylinder, use durable fittings (Stainless steel square nipples etc.) instead of ductile iron fittings (JIS B 2301) or steel pipe fittings (JIS B 2302).

When VNA is installed away from the cylinder, use a high-pressure rubber hose (JIS B 6349) instead of steel pipe, when possible.

#### ⚠ Warning

##### 1. Air bleeding

Series VNA valves have no air bleeding port. Bleed air comes from the middle piping. Bleeding by a vacuum pump is more effective.

##### 2. Hydraulic fluid

Turbine oil, Grade 1 ISO VG32, with petroleum hydraulic fluid is recommended.

##### 3. Speed control valve

The combination shown in the following table is recommended for best performance of the Series VNA. (Piping: JIS K 6349 high pressure hose)

### Combination between Series VNA and Flow Controller (Series AS)

	VNA	AS	Piping (I.D.)
10A	111	420-03	$\frac{3}{8}$ B (ø9.5)
15A	211	420-04	$\frac{1}{2}$ B (ø12.7)
20A	311	500-06	$\frac{3}{4}$ B (ø19.1)
25A	411	600-10	1 B (ø25.4)
32A	511	800-12	1 $\frac{1}{4}$ B (ø31.8)
40A	611	900-14	1 $\frac{1}{2}$ B (ø38.1)
50A	711	900-20	2 B (ø50.8)

# Process Valve: 2 Port Valve For Compressed Air and Air-hydro Circuit Control **Series VNA**

## Construction

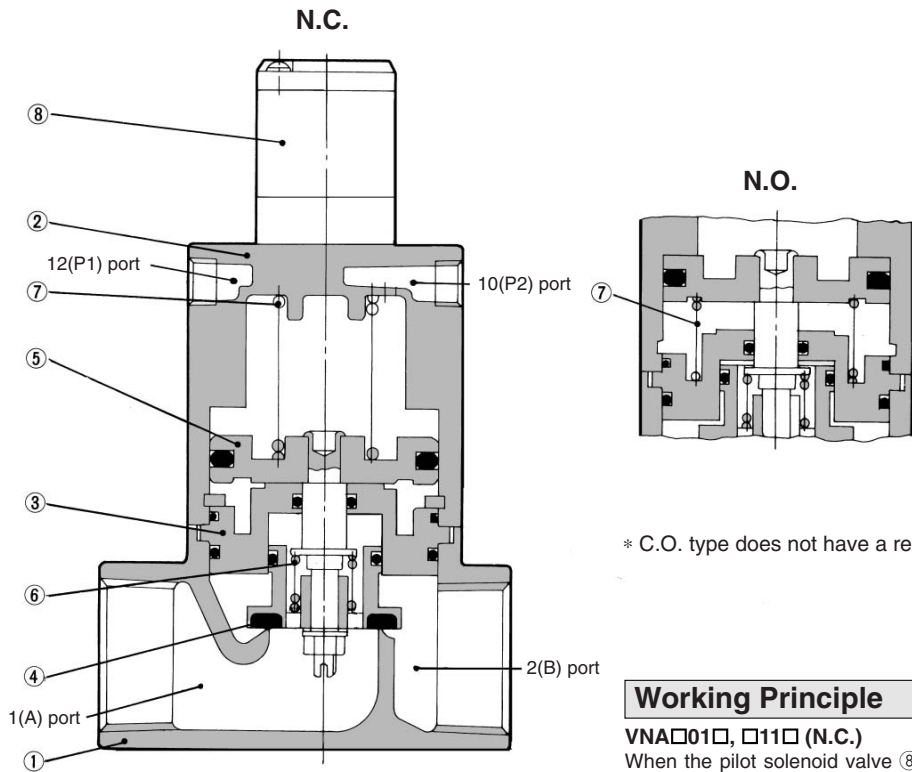

\* C.O. type does not have a return spring ⑦.

### Working Principle

#### VNA□01□, □11□ (N.C.)

When the pilot solenoid valve ⑧ is not energized (or when air is exhausted from the 12(P1) port of the air operated style), the valve element ④ linked to the piston ⑤ is closed by the return spring ⑦.

#### ● When valve element opens

When the pilot solenoid valve is energized (or when pressurized air enters through the 12(P1) port of the air operated style), the pilot air that has entered under the piston moves upward to open the valve element.

#### ● When valve element closes

When the power to the pilot solenoid valve is turned off (or when fluid is exhausted from the 12(P1) port of the air operated style), the pilot air under the piston is exhausted, and the return spring closes the valve element.

#### VNA□02□, □12□ (N.C.)

In contrast with the N.C., when the power to the pilot solenoid valve is turned off (or when air is exhausted from the 10(P2) port of the air operated style), the valve is held open by the return spring. When the pilot solenoid valve is energized (or when pressurized air enters through the 10(P2) port of the air operated style), the valve element closes.

#### VNA□03□ (C.O.)

The valve element of the C.O. type, which has no return spring, is in an arbitrary position when air is exhausted through the 12(P1) and 10(P2) ports. When pressurized air enters the 12(P1) port (exhaust from the 10(P2) port), the valve element opens, and it closes when pressurized air enters the 10(P2) port.

## Component Parts

No.	Description	Material	Note
①	Body	Aluminum alloy	Platinum silver painted
②	Cover assembly	Aluminum alloy	Platinum silver painted
③ (Note)	Plate assembly	Aluminum alloy	Valve material (NBR, FKM, EPR)
④ (Note)	Valve element	Aluminum alloy	Valve material (NBR, FKM, EPR)
⑤	Piston assembly	Aluminum alloy	—
⑥	Travel spring	Stainless steel	—
⑦	Return spring	Piano wire	—
⑧	Pilot solenoid valve	—	—

Note) Parts ③ and ④ are for selection of valve composition.

## Replacement Parts

No.	Description	Part no.								
		VNA1□□A -6A, 8A, 10A	VNA2□□□ -10A, 15A	VNA3□□□ -20A	VNA4□□□ -25A	VNA5□□□ -32A	VNA6□□□ -40A	VNA7□□□ -50A		
③	Plate assembly	Valve Composition	NBR	VN1-A3AA	VN2-A3AA	VN3-A3AA	VN4-A3AA	VN5-A3AA	VN6-A3AA	VN7-A3AA
			FKM	VN1-A3AB	VN2-A3AB	VN3-A3AB	VN4-A3AB	VN5-A3AB	VN6-A3AB	VN7-A3AB
			EPR	VN1-A3AC	VN2-A3AC	VN3-A3AC	VN4-A3AC	VN5-A3AC	VN6-A3AC	VN7-A3AC
④	Valve disc (Valve disc assembly for 25A-50A)	Valve Composition	NBR	VN1-4AA	VN2-4AA	VN3-4AA	VN4-A4AA	VN5-A4AA	VN6-A4AA	VN7-A4AA
			FKM	VN1-4AB	VN2-4AB	VN3-4AB	VN4-A4AB	VN5-A4AB	VN6-A4AB	VN7-A4AB
			EPR	VN1-4AC	VN2-4AC	VN3-4AC	VN4-A4AC	VN5-A4AC	VN6-A4AC	VN7-A4AC
⑧	Pilot solenoid valve	SF4-□□□-23 (Refer to page 17-4-12 for details.)					VO301-00□□□ (Refer to page 17-4-12 for details.)			

VC□

VDW

VQ

VX2

VX□

VX3

VXA

VN□

LVC

LVA

L VH

LVD

L VQ

LQ

L VN

TI/  
TIL

PA

PAX

PB



# Series VNA

## How to Order Pilot Solenoid Valves

### Valve size 1/2/3/4

SF4 — 1 — DZ — 23

#### Coil rated voltage

- 1 — 100 VAC 50/60 Hz
- 2 — 200 VAC 50/60 Hz
- 3\* — 110 VAC 50/60 Hz
- 4\* — 220 VAC 50/60 Hz
- 5 — 24 VDC
- 6\* — 12 VDC
- 7\* — 240 VAC 50/60 Hz
- 9\* — Other

\* Option

#### Manual override

- Nil — Non-locking push type
- A\* — Non-locking extended type
- B\* — Locking slotted type

\* Option

#### Electrical entry/ With light/surge voltage suppressor

<b>G</b>	Grommet
<b>GS</b>	Grommet with surge voltage suppressor
<b>E</b>	Grommet terminal
<b>EZ</b>	Grommet terminal with light/surge voltage suppressor
<b>T</b>	Conduit terminal
<b>TZ</b>	Conduit terminal with light/surge voltage suppressor
<b>D</b>	DIN terminal
<b>DZ</b>	DIN terminal with light/surge voltage suppressor

### Valve size 5/6/7

VO301-00 — — —

#### Coil rated voltage

- 1 — 100 VAC 50/60 Hz
- 2 — 200 VAC 50/60 Hz
- 3\* — 110 VAC 50/60 Hz
- 4\* — 220 VAC 50/60 Hz
- 5 — 24 VDC
- 6\* — 12 VDC
- 7\* — 240 VAC 50/60 Hz
- 9\* — Other

\* Option

#### With surge voltage suppressor

- Nil — None
- S — Surge voltage suppressor (Except "DL")

#### Electrical entry

- G — Grommet
- C — Conduit
- T <sup>Note)</sup> — Conduit terminal
- D — DIN terminal
- DL\* — DIN terminal with indicator light

\* Option



Note) When the electrical entry is T, the pilot solenoid valve parts are as follows;  
VO301-00□□□-X302

Light/Surge voltage Suppressor

Coil rated voltage

Accessory

Function plate (D seal, with screw): DXT060-32-4A