

Coolant Valve: Air Operated/External Pilot Solenoid Series VNC

Cylinder actuation by pilot air

Wide selection of port size and variations
Threaded type (6A to 50A)
Flange type (32F to 80F)

Low water hammer
Max. 1.2 MPa

In the case of VNC211A
(N.C. 0.5 MPa)

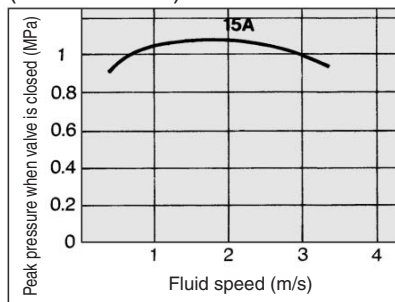

Conditions: Piping length/30 m
Steel tube, full pressure/0.5 MPa

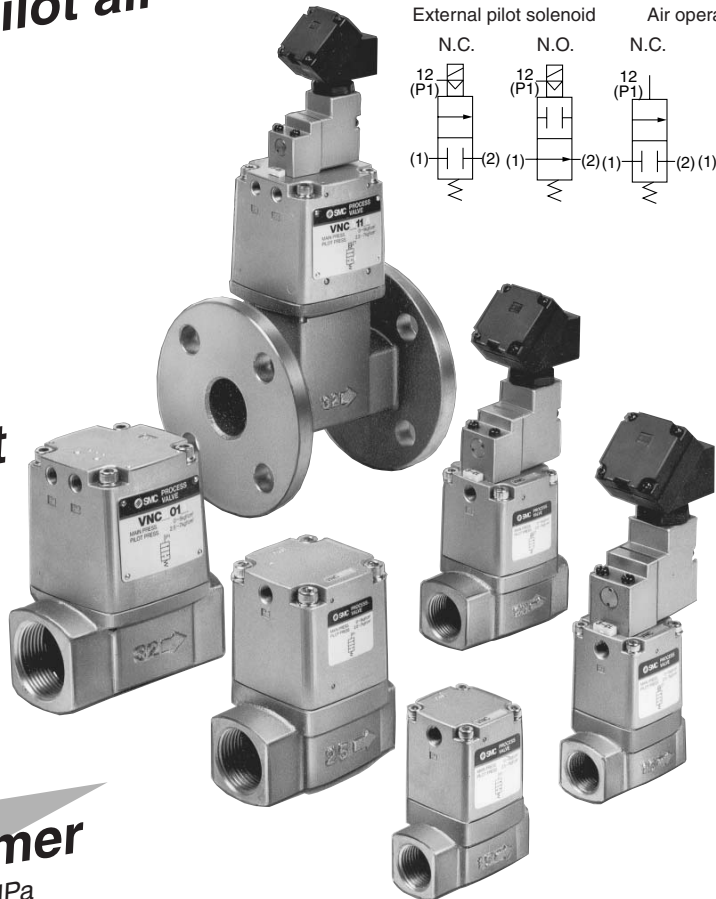
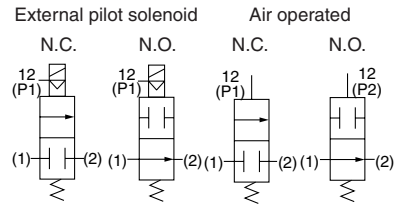

- VC □
- VDW
- VQ
- VX2
- VX □
- VX3
- VXA
- VN □**
- LVC
- LVA
- LVH
- LVD
- LVQ
- LQ
- LVN
- TI/
TIL
- PA
- PAX
- PB

Large valve capacity

Av factor 3.0×10^5 to 160×10^5
(VNC1 to VNC7)
Cv factor 49 to 100
(VNC8 to VNC9)

Series VNC

How to Order

Seal material

A	NBR seals
B	FKM seals

Thread type

Nil	Rc
F	G
N	NPT
T	NPTF

Bracket (Valve size: 1/2/3/4)

Nil	None
B	With bracket (VN□-16) * □ is valve size

Note 1) Valve size 1 comes with VN1-A16 (with thread).
Note 2) Shipped after assembled at our factory.

Air operated VNC 2 0 1 A □ 15A □ (Except valve size 8, 9)

External pilot solenoid VNC 2 1 1 A □ 15A 1 T □ □

Symbol	Orifice size (mm)	Symbol			Symbol	Port size Rc
		1	2	4		
		N.C. 0.5 MPa	N.O. 1 MPa	N.C. 1 MPa		
1	ø7	-	●	●	6A	1/8
		-	●	●	8A	1/4
		-	●	●	10A	3/8
2	ø15 (ø11)	●	●	●	10A	3/8
		●	●	●	15A	1/2
		●	●	●	20A	3/4
3	ø20 (ø14)	●	●	●	25A	1
		●	●	●	32A	1 1/4
5	ø32 (ø22)	●	●	●	32F	1 1/4 B Flange
		●	●	●	40A	1 1/2
		●	●	●	40F	1 1/2 B Flange
7	ø50 (ø33)	●	●	●	50A	2
		●	●	●	50F	2B Flange
8	ø65 (ø45)	●	-	●	65F	2 1/2 B Flange
		●	-	●	80F	3B Flange

Rated voltage

Nil	Air operated
1	100 VAC 50/60 Hz
2	200 VAC 50/60 Hz
3*	110 VAC 50/60 Hz
4*	220 VAC 50/60 Hz
5	24 VDC
6*	12 VDC
7*	240 VAC 50/60 Hz
9*	Other

* Option

Manual override

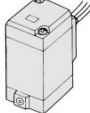
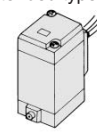
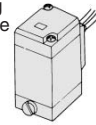
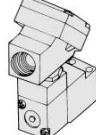
<p>Nil: Non-locking push type</p> 	<p>A: Non-locking extended type</p> 	Valve size 1
<p>B: Locking slotted type</p> 		
<p>Nil: Non-locking push type</p> 		Valve size 2 to 9

Electrical entry/With light/surge voltage suppressor

Nil	Air operated	Valve size 1
G	Grommet	
GS	Grommet with surge voltage suppressor	
E	Grommet terminal	
EZ	Grommet terminal with light/surge voltage suppressor	
T	Conduit terminal	
TZ	Conduit terminal with light/surge voltage suppressor	
D	DIN terminal	
DZ	DIN terminal with light/surge voltage suppressor	
T	Conduit terminal	
TS	Conduit terminal with surge voltage suppressor	Valve** size 2 to 9
TZ*	Conduit terminal with light/surge voltage suppressor	
TL*	Conduit terminal with indicator light	

* Except rated voltage: 6, 7 and 9.
** DZ: For DIN terminal with light/surge suppressor protection circuit, be sure to add suffix -X200 at the end of the part number. In this case, pilot solenoid valve is VO307-□DZ.

Values in parentheses are N.C. at 1 MPa.

Coolant Valve: Air Operated/External Pilot Solenoid **Series VNC**

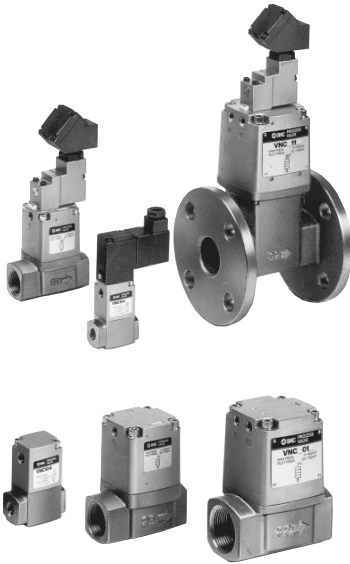

Model

Model	Port size		Orifice size ø (mm)	Flow characteristics		Weight (kg)	
	Threaded	(Note) Flange		Av x 10 ⁻⁶ m ²	Air operated	External pilot Solenoid	
VNC1□□□-6A	1/8	—	7	30	0.2	0.3	
VNC1□□□-8A	1/4	—		32			
VNC1□□□-10A				36			
VNC2□4□-10A	3/8	—	11	95	0.5	0.7	
VNC2□□□-10A			15	120			
VNC2□4□-15A	1/2	—	11	110			
VNC2□□□-15A			15	140	0.8	1.0	
VNC3□4□-20A	3/4	—	14	170			
VNC3□□□-20A			20	260			
VNC4□4□-25A	1	—	16	220	1.2	1.4	
VNC4□□□-25A			25	370			
VNC5□4□-32A	1 1/4	—	22	400			
VNC5□□□-32A			32	560	2.2	2.4	
VNC5□4□-32F	—	32	22	400			
VNC5□□□-32F			32	560			
VNC6□4□-40A	1 1/2	—	28	630	3.6	3.8	
VNC6□□□-40A			40	820			
VNC6□4□-40F	—	40	28	720			
VNC6□□□-40F			40	960	6.8	7.0	
VNC7□4□-50A	2	—	33	990			
VNC7□□□-50A			50	1500			
VNC7□4□-50F	—	50	33	1000	10.2	10.4	
VNC7□□□-50F			50	1600			



(Note) The companion flange is JIS B 2210 10K (standard) or its equivalent.

JIS Symbol

Valve type Operation	N.C.	N.O.
Air operated	VNC□□ ₄ □ 	VNC□02□
	VNC□1 ₄ □ 	VNC□12□



(Note) The companion flange is JIS B 2210 10K (standard) or its equivalent.

Model	Port size Flange (Note)	Orifice size ø (mm)	Flow characteristics		Weight (kg)	
			Cv	Effective area (mm ²)	External pilot solenoid	
VNC814□-65F	65	45	49	880	15.7	
VNC811□-65F		65	70	1260		
VNC914□-80F		56	73	1400		
VNC911□-80F	80	80	100	1800	21.2	

Valve specifications

Fluid	Coolant
Fluid temperature	VNC□□□A: -5 to 60°C*
	VNC□□□B: -5 to 99°C*
	(Air operated type only)
Ambient temperature	-5 to 50°C (Air operated type: 60°C) *
Proof pressure	1.5 MPa
Applicable pressure range	VNC□□1□: 0 to 0.5 MPa
	VNC□□ ₂ □: 0 to 1 MPa
External pilot air	Pressure
	VNC□□ ₄ □: 0.25 to 0.7 MPa
	VNC□□2□: 0.1 + 0.25 x (Operating pressure) to 0.7 MPa. Refer to "Graph (1)".
Lubrication	Not required (Use turbine oil Class 1 ISO VG32, if lubricated.)
Temperature	-5 to 50°C (Air operated type: 60°C) *



* No freezing

Graph (1) VNC□□2□ Pilot Pressure (N.O. type)

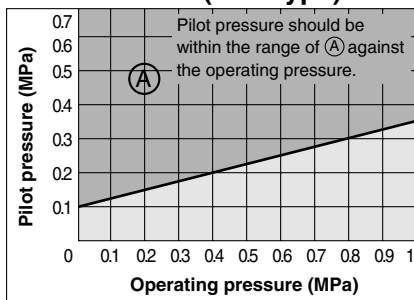

Pilot Solenoid Valve Specifications

Model		VNC1□□□□	VNC2□□□□ to 9□□□□	
Pilot solenoid valve		SF4-□□□-23	VO301-00□□-X302	
Electrical entry		Grommet Grommet terminal Conduit terminal DIN terminal	Conduit terminal	
Coil rated voltage (V)	AC (50/60 Hz)	100 V, 200 V, Other voltage (Option)		
	DC	24 V, Other voltage (Option)		
Allowable voltage fluctuation		-15% to +10% of rated voltage		
Coil insulation type		Class B or equivalent (130°C)		
Temperature rise		35°C or less (when rated voltage is applied.)	70°C or less (when rated voltage is applied.)	
Apparent power	AC	Inrush	5.6 VA (50 Hz) 5.0 VA (60 Hz)	12 VA (50 Hz) 10.5 VA (60 Hz)
		Holding	3.4 VA (50 Hz) 2.3 VA (60 Hz)	7.5 VA (50 Hz) 6 VA (60 Hz)
Power consumption		DC	1.8 W	4.8 W
Manual override		Non-locking push type, Other (Option)		Non-locking push type

VC□

VDW

VQ

VX2

VX□

VX3

VXA

VN□

LVC

LVA

LVH

LVD

LVQ

LQ

LVN

TI/
TIL

PA

PAX

PB

Series VNC

Threaded Type Port size: 6A, 8A, 10A

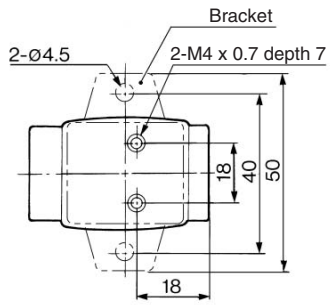
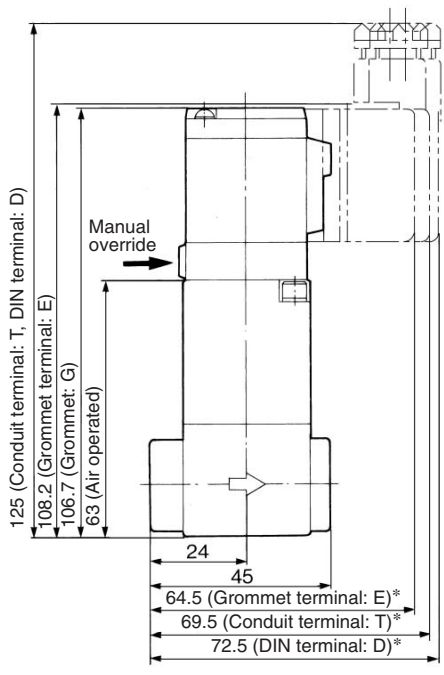
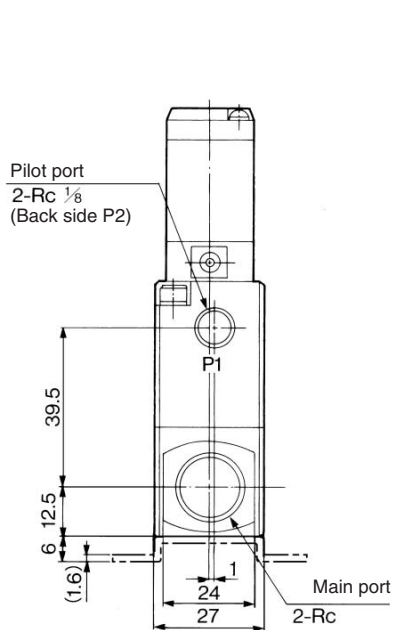

Model	Main port Rc
VNC1□□□-6A	1/8
VNC1□□□-8A	1/4
VNC1□□□-10A	3/8

* In the case of "EZ" or "TZ" or "DZ", the length is longer by 9 mm.

Coolant Valve: Air Operated/External Pilot Solenoid **Series VNC**

Threaded Type Port size: 10A, 15A, 20A, 25A

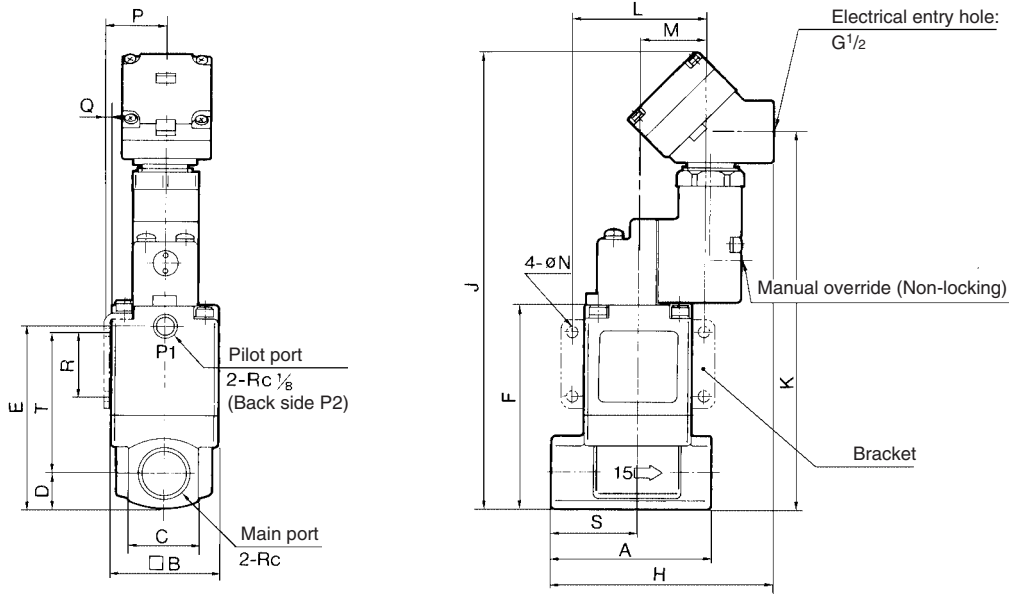

Model	Main port Rc	A	B	C	D	E	F	H	J	K	L	M	N	P	Q	R	S	T
VNC2□□□-10A	3/8	63	42	28	14	72.5	80.5	87	180.5	148	52	26	4.5	24.3	2.3	25	34	55
VNC2□□□-15A	1/2	63	42	28	14	72.5	80.5	87	180.5	148	52	26	4.5	24.3	2.3	25	34	55
VNC3□□□-20A	3/4	80	50	35	17.5	84	92	92	192	159.5	62	31	5.5	28.3	2.3	30	43	60.5
VNC4□□□-25A	1	90	60	40	20	100	108	93	208	175.5	72	36	6.5	33.3	2.3	35	49	73

- VC□
- VDW
- VQ
- VX2
- VX□
- VX3
- VXA
- VN□
- LVC
- LVA
- L VH
- LVD
- LVQ
- LQ
- LVN
- TI/
TIL
- PA
- PAX
- PB

Threaded Type Port size: 32A, 40A, 50A

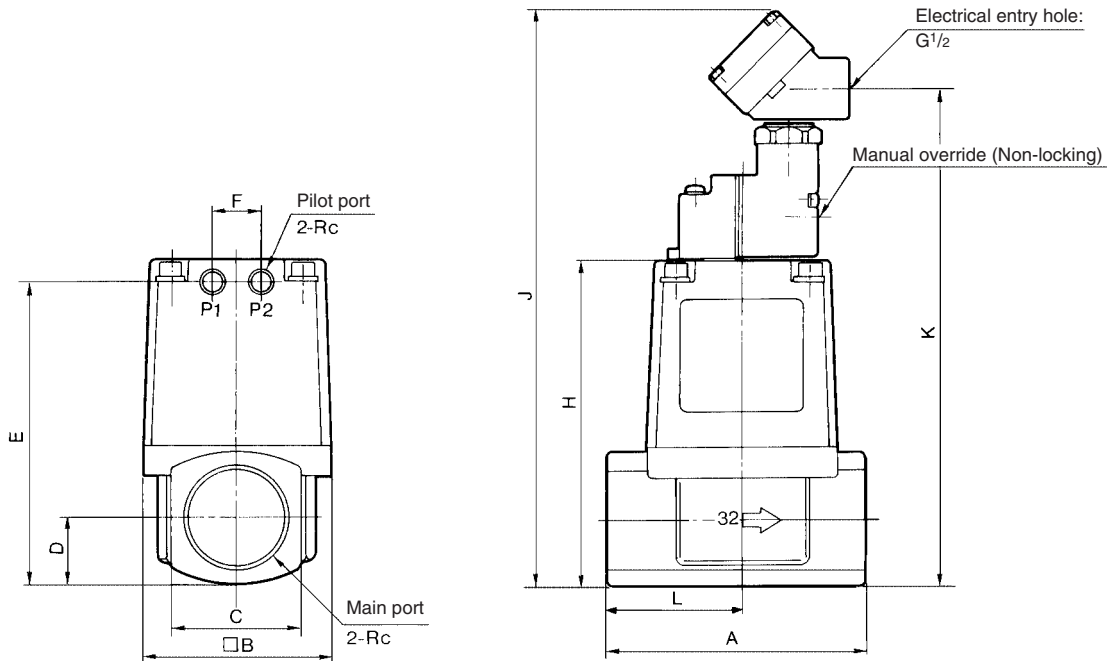

Model	Main port Rc	Pilot port Rc	A	B	C	D	E	F	H	J	K	L
VNC5□□□-32A	1 1/4	1/8	105	77	53	26.5	120.5	20	129.5	229.5	197	55
VNC6□□□-40A	1 1/2	1/4	120	96	60	30	137	24	147	247	214.5	63
VNC7□□□-50A	2	1/4	140	113	74	37	160	24	170	270	237.5	74

Series VNC

Flange Type Port size: 32F, 40F, 50F

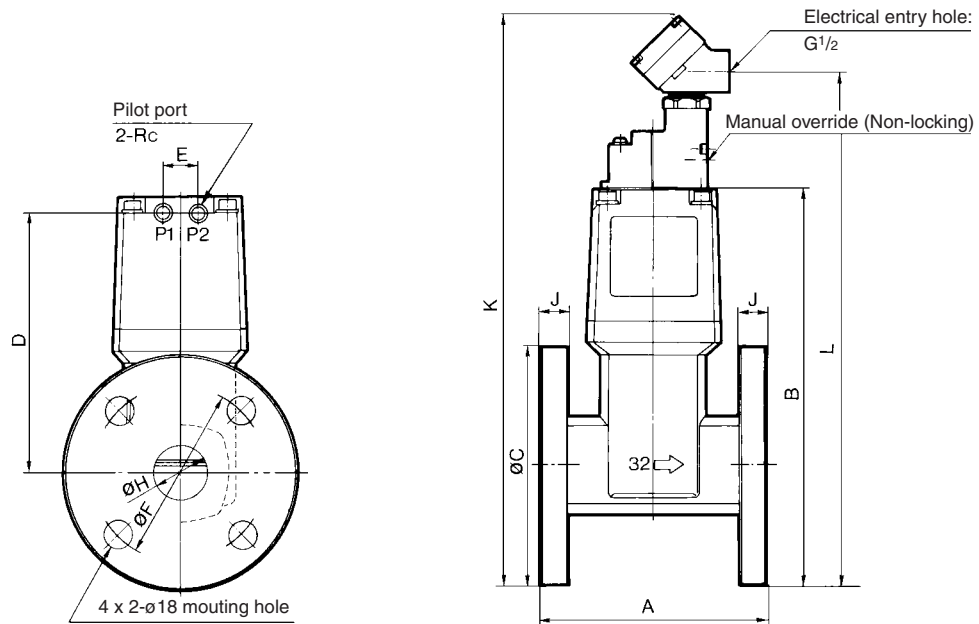

Model	Applicable flange	Pilot port Rc	A	B	C	D	E	F	H	J	K	L
VNC5□□□-32F	32	1/8	130	210.5	135	134	20	100	36	12	310.5	278
VNC6□□□-40F	40	1/4	150	226	140	146	24	105	42	12	326	293.5
VNC7□□□-50F	50	1/4	180	250	155	162.5	24	120	54	14	350	317.5

Flange Type Port size: 65F, 80F

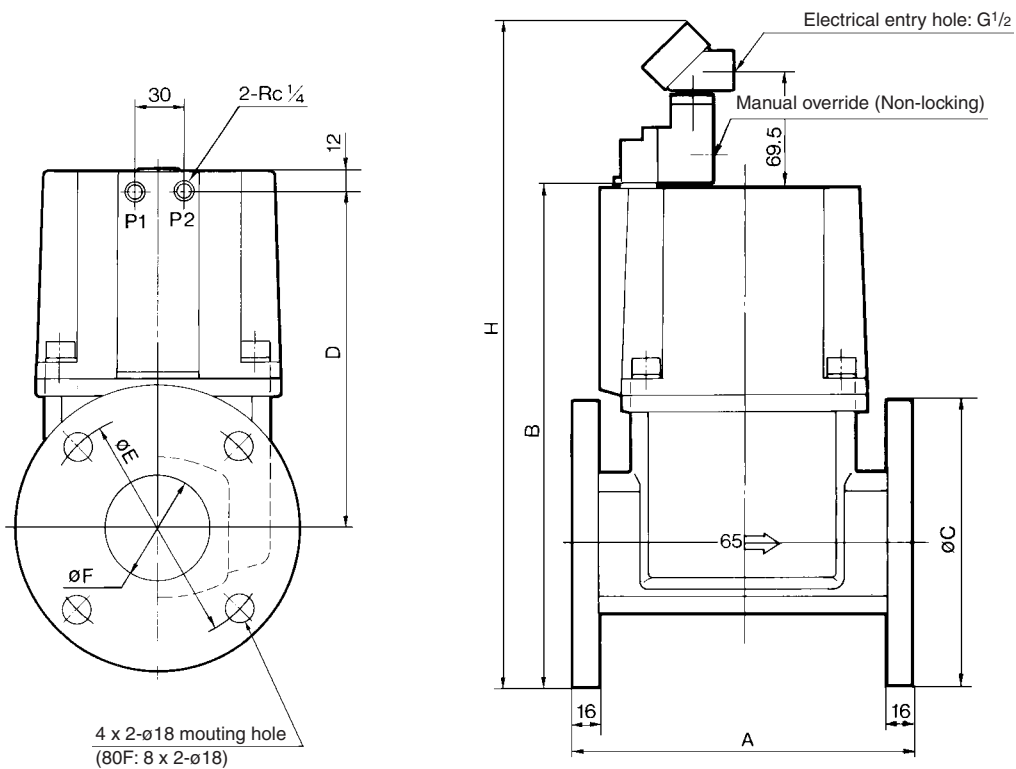

Model	Applicable flange	A	B	C	D	E	F	H
VNC81□□-65F	65	210	305.5	175	204	140	65	405.5
VNC91□□-80F	80	240	341.5	185	235	150	80	441.5

Coolant Valve: Air Operated/External Pilot Solenoid **Series VNC**

⚠ Precautions

Be sure to read before handling.

Refer to page 17-6-3 for Safety Instructions and Solenoid Valve Precautions.

External Pilot

⚠ Caution

Pilot port 12(P1) and 10(P2) piping

P1 and P2 piping should be as follows according to the model.

Port	Air operated		Solenoid
	VNC□0 $\frac{1}{4}$ □	VNC□02□	VNC□1 $\frac{1}{4}$ □
12 (P1)	External pilot	Bleed port	External pilot
10 (P2)	Bleed port	External pilot	Pilot exhaust

Installing a silencer to the exhaust port and the bleed port is recommended for noise reduction and for dust entry prevention.

Piping

⚠ Caution

When high temperature fluids are used, use fittings and tube with heat resistant features. (Self-align fittings, Teflon® tubing, Copper piping, etc.)

Mounting Direction of Pilot Solenoid Valve

⚠ Caution

When replacing a valve, if an external pilot solenoid valve is mounted in the wrong direction, it may malfunction or leak air.

VC□

VDW

VQ

VX2

VX□

VX3

VXA

VN□

LVC

LVA

LVH

LVD

LVQ

LQ

LVN

TI/
TIL

PA

PAX

PB

Series VNC

Construction

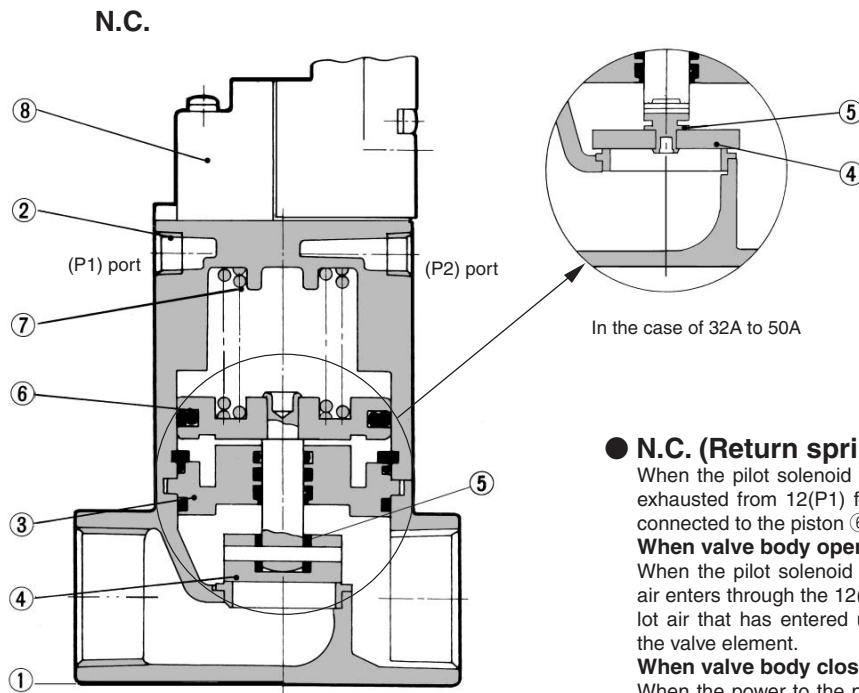

● N.C. (Return spring normally closed)

When the pilot solenoid valve ⑧ is not energized (or when air is exhausted from 12(P1) for air operated style), the valve body ④ connected to the piston ⑥ is closed by the return spring ⑦.

When valve body opens

When the pilot solenoid valve is energized (or when pressurized air enters through the 12(P1) port of the air operated style), the pilot air that has entered under the piston moves upward to open the valve element.

When valve body closes

When the power to the pilot solenoid valve is turned off (or when fluid is exhausted from the 12(P1) port of the air operated style), the pilot air under the piston is exhausted, and the return spring closes the valve element.

N.O.

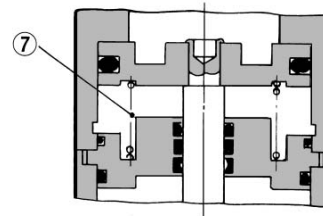

● N.O. (Return spring normally open)

In contrast with the N.C., when the pilot solenoid valve is not energized (or when air is exhausted from the 10(P2) port of the air operated style), the valve body is opened by the return spring. When the pilot solenoid valve is energized (or when pressurized air enters through the 10(P2) port of the air operated style), the valve body closes.

Component Parts

No.	Description	Material	Note
①	Body assembly	Cast iron	Plated
②	Cover assembly	Aluminum alloy	Platinum silver painted
③	Plate assembly	Iron	Valve composition, NBR, FKM
④	Valve element	Stainless steel	
⑤	Valve cover	NBR, FKM	32A to 50A are O-ring.
⑥	Piston assembly	Aluminum alloy	
⑦	Return spring	Piano wire	
⑧	Pilot solenoid valve	—	

Note) ③⑤ components determine the valve composition.

Replacement Parts

No.	Description	Part no.								
		VNC1□□□ -6A, 8A, 10A	VNC2□□□ -10A, 15A	VNC3□□□ -20A	VNC4□□□ -25A	VNC5□□□ -32A, 32F	VNC6□□□ -40A, 40F	VNC7□□□ -50A, 50F		
③	Plate ass'y	Valve material	NBR	VN1-A3CA	VN2-A3CA	VN3-A3CA	VN4-A3CA	VN5-A3CA	VN6-A3CA	VN7-A3CA
		FKM	VN1-A3CB	VN2-A3CB	VN3-A3CB	VN4-A3CB	VN5-A3CB	VN6-A3CB	VN7-A3CB	
⑤	Valve cover (32A to 50A are O-ring.)	Valve material	NBR	—	VN2-12CA	VN4-12CA	AS568-010	AS568-011	AS568-012	
		FKM	—	VN2-12CB	VN4-12CB					
⑧	Pilot solenoid valve	SF4-□□□-23		VO301-00□□□-X302 (Refer to page 17-4-29 for part no.)						

Replacement Parts: Applicable Flange

No.	Description	Part no.			
		VNC811□-65F	VNC911□-80F		
③	Plate assembly	Valve material	NBR	VN8-A3CA	VN9-A3CA
		FKM	VN8-A3CB	VN9-A3CB	
⑧	Pilot solenoid valve	VO301-00□□□-X302 (Refer to page 17-4-29 for part no.)			

Coolant Valve: Air Operated/External Pilot Solenoid **Series VNC**

How to Order Pilot Solenoid Valves

Valve size 1

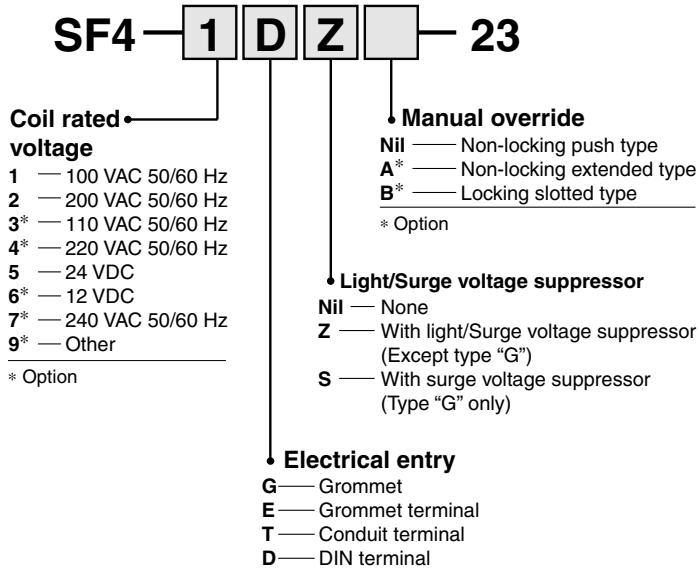

Valve size 2 to 9

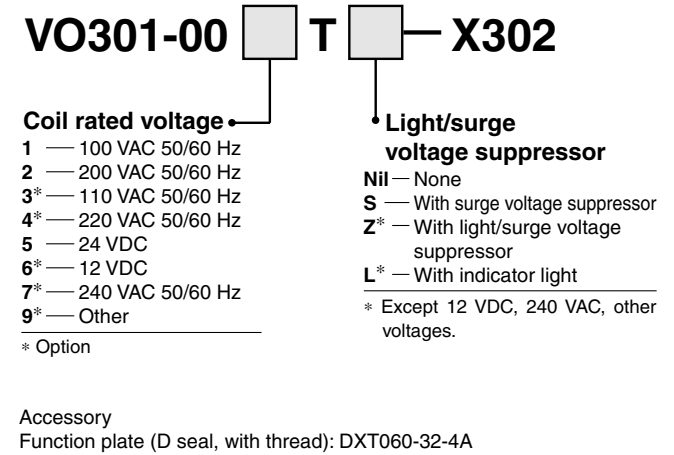

- VC
- VDW
- VQ
- VX2
- VX
- VX3
- VXA
- VN
- LVC
- LVA
- LVH
- LVD
- LVQ
- LQ
- LVN
- TI/
TIL
- PA
- PAX
- PB