

High Pressure Coolant Valve: 3.5 MPa, 7.0 MPa Series VNH

Corresponding to high speed grinding and long drilling processes

Valve for high pressure coolant liquid (up to 3.5 MPa or 7.0 MPa) that is ideal for lubrication, dust blowing and cooling.

Valve for coolant



- VC
- VDW
- VQ
- VX2
- VX
- VX3
- VXA
- VN
- LVC
- LVA
- L VH
- LVD
- LVQ
- LQ
- LVN
- TI/TIL
- PA
- PAX
- PB

Pilot air operated cylinder driving mechanism. Metal seal with poppet valve structure.

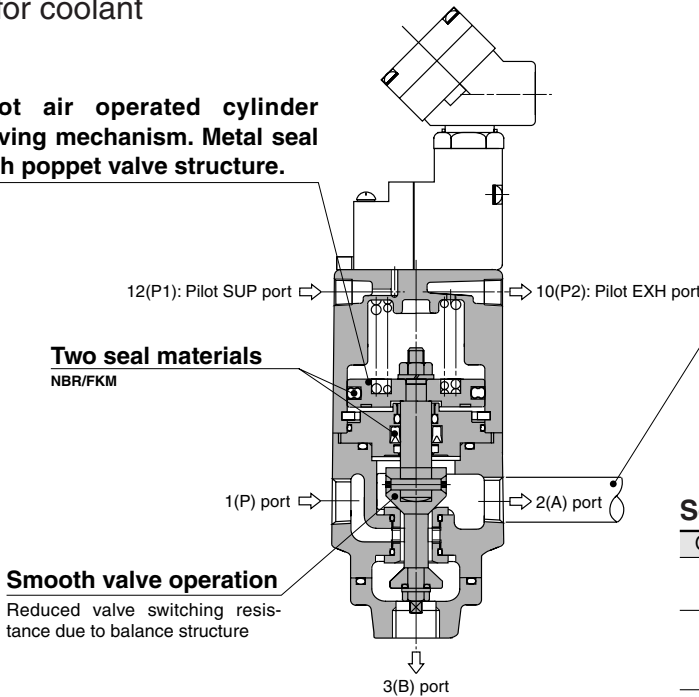

Easy maintenance
Parts can be exchanged without removing the existing main piping

Smooth valve operation
Reduced valve switching resistance due to balance structure

Series

Operating fluid pressure	Port	Port size Rc
3.5 MPa	3 Port	3/8(10A), 1/2(15A)
		3/4(20A), 1(25A)
7.0 MPa	2 port (Large flow type)	3/8(10A), 1/2(15A)
	3 Port	3/4(20A), 1(25A)

... Application Example ...

3 port valve (3.5 MPa, 7.0 MPa)

Piping

Inlet side (supply side): P port, Outlet side (exhaust side): A and B port. Supply pilot air higher than 0.25 MPa to P1 port

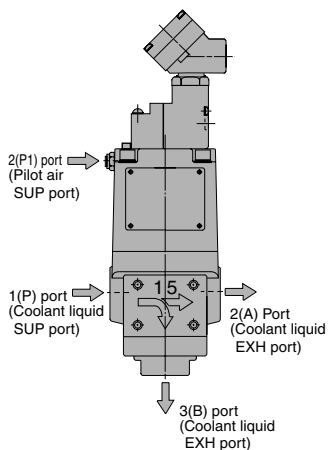

Ex. 1) 3 port valve: Reducing load to pump

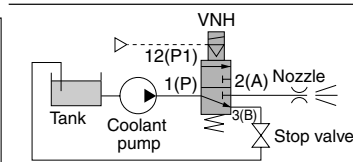

For reducing load to pump, coolant liquid is returned from B port to tank each time.

Ex. 2) 3 port valve: Switching nozzle

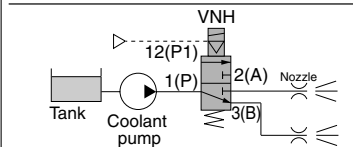

Switching nozzles on supplying coolant liquid.

Ex. 3) 2 port valve: Nozzle ON/OFF

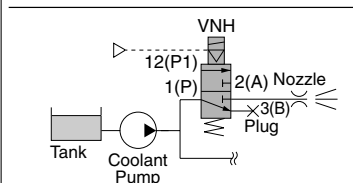

2 port valve application
(Not applicable for 7.0 MPa model)

2 port valve (7.0 MPa)

Piping

Inlet side (supply side): P port, Outlet side (exhaust side): A port Supply pilot air higher than 0.25 MPa to P1 port.

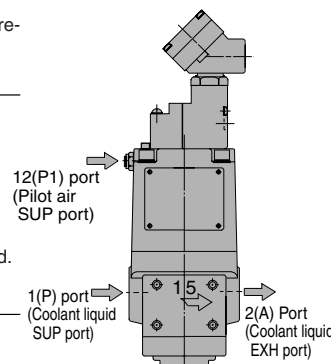

Ex.1) 2 port valve: Nozzle ON/OFF

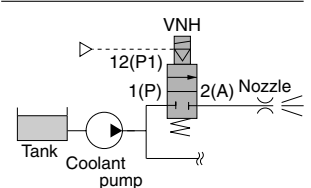

Series VNH

How to Order

VNH 2 1 1 A — 15A — 1 T —

Note) Silencer is provided as standard on pilot EXH port (P2).

Port

1	3 port
3*	2 port

* 2 port is 7.0 MPa only.

Valve type

1	N.C./3.5 MPa
3	N.C./7.0 MPa

Gasket material

A	NBR seals
B	FKM seals

Thread type

Nil	Rc
F	G
N	NPT
T	NPTF

Bracket

Nil	None
B	With bracket

Electrical entry/With light/surge voltage suppressor

T	Conduit terminal
TS	Conduit terminal with surge voltage suppressor
TZ*	Conduit terminal with light/surge voltage suppressor
TL*	Conduit terminal with indicator light

* Rated voltage: Except 6, 7, 9.

Rated voltage

Nil	Air operated
1	100 VAC 50/60 Hz
2	200 VAC 50/60 Hz
3*	110 VAC 50/60 Hz
4*	220 VAC 50/60 Hz
5	24 VDC
6*	12 VDC
7*	240 VAC 50/60 Hz
9*	Other

* Option

Valve size

1	10A	Rc 3/8
2	15A	Rc 1/2
3	20A	Rc 3/4
4	25A	Rc1

Port size

Option

Description	Component part no.				
	VNH1□□	VNH2□□	VNH3□□	VNH4□□	
Bracket (With bolt and washer)	B	VNH1-16	VNH2-16	VNH3-16	VNH4-16

How to Order Pilot Solenoid Valves

VO301-00 □ T □ — X302

Rated voltage

1	100 VAC 50/60 Hz
2	200 VAC 50/60 Hz
3*	110 VAC 50/60 Hz
4*	220 VAC 50/60 Hz
5	24 VDC
6*	12 VDC
7*	240 VAC 50/60 Hz
9*	Other

* Option

Light/surge voltage suppressor

Nil	None
S	With surge voltage suppressor
Z	With light/surge voltage suppressor
L	With indicator light

Accessory

Function plate (D sealing, with thread): DXT060-32-4A

High Pressure Coolant Valve 3.5 MPa, 7.0 MPa Series VNH

Specifications

Model	3 port valve								2 port valve			
	VNH111 ^A _B -10A	VNH211 ^A _B -15A	VNH311 ^A _B -20A	VNH411 ^A _B -25A	VNH113 ^A _B -10A	VNH213 ^A _B -15A	VNH313 ^A _B -20A	VNH413 ^A _B -25A	VNH133 ^A _B -10A	VNH233 ^A _B -15A	VNH333 ^A _B -20A	VNH433 ^A _B -25A
Operating fluid pressure	0 to 3.5 MPa				0 to 7.0 MPa							
Fluid	Coolant											
Operation	External pilot solenoid/Air operated											
Operating fluid temperature	-5 to 60°C */-5 to 60°C * (NBR seal)											
	-5 to 60°C */-5 to 99°C * (FKM seal)											
Pilot air	Pressure 0.25 to 0.7 MPa											
	Temperature -5 to 50°C *											
	Lubrication Not required (Use turbine oil Class 1 ISO VG32, if lubricated.)											
Proof pressure	5.5 MPa				10.5 MPa							
Ambient temperature	-5 to 50°C *											
Max. operating frequency	20 times/min											
Mounting position	Vertical upwards											
Port size	Rc 3/8	Rc 1/2	Rc 3/4	Rc1	Rc 3/8	Rc 1/2	Rc 3/4	Rc1	Rc 3/8	Rc 1/2	Rc 3/4	Rc1
Orifice size (mm)	ø7.1 **	ø8.7 **	ø10.6 **	ø14.3 **	ø3.9 **	ø5.2 **	ø6.2 **	ø7.3 **	ø8	ø9.5	ø13	ø15.7
Flow characteristics Av x 10 ⁻⁵	46	86	110	190	15	29	38	58	54	75	140	210
Pilot port size	Rc 1/8		Rc 1/4		Rc 1/8		Rc 1/4		Rc 1/8		Rc 1/4	
Weight (kg)	2	3.1	5.6	8.2	2	3.1	5.6	8.2	2	3.1	5.6	8.2
Face-to-face dimension (mm)	60	80	100	115	60	80	100	115	60	80	100	115

⊙ * No freezing
** Equivalent size



Pilot Operated Solenoid Valve Specifications

Pilot solenoid valve	VO301-00□□-X302		
Electrical entry	Conduit terminal		
Coil rated voltage (V)	AC (50/60/Hz)	100 V, 200 V, Other voltage (Option)	
	DC	24 V, Other voltage (Option)	
Allowable voltage fluctuation	-15 to 10% of the rated voltage		
Coil insulation type	Class B or equivalent (130°C)		
Temperature rise	70°C or less (When rated voltage is applied.)		
Apparent power	AC	Inrush	12 VA (50 Hz), 10.5 AV (60 Hz)
		Holding	7.5 VA (50 Hz), 6 VA (60 Hz)
Power consumption	DC	4.8 W	
Manual override	Non-locking push type		

JIS Symbol

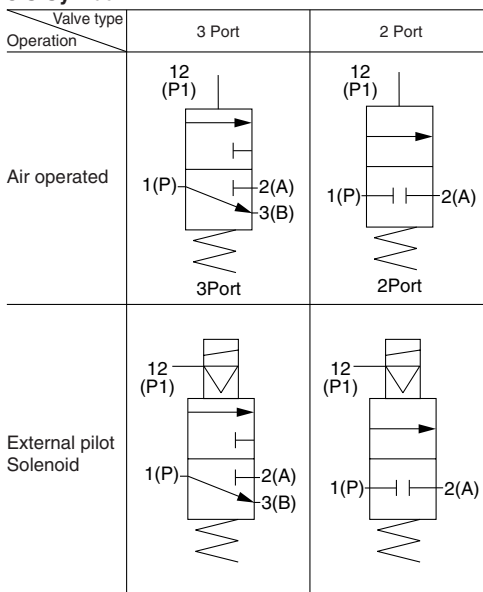

VC□

VDW

VQ

VX2

VX□

VX3

VXA

VN□

LVC

LVA

LVH

LVD

LVQ

LQ

LVN

TI/
TIL

PA

PAX

PB

Series VNH

Dimensions

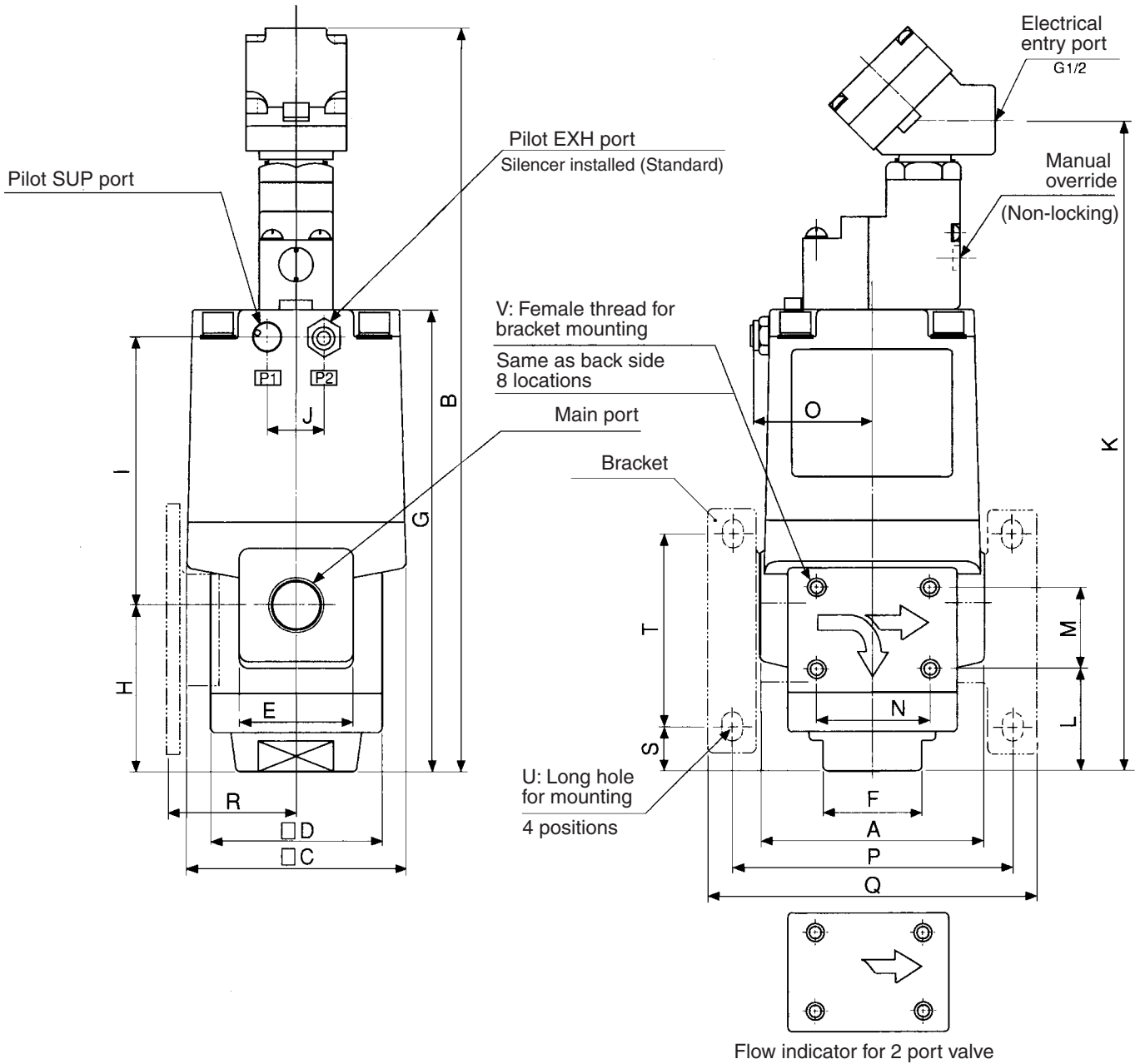

Dimensions

(mm)

Model	Main port		Pilot port	A	B	C	D	E	F	G	H	I
	2 Port	3 Port										
VNH1□□ ^A -10A	2-Rc 3/8	3-Rc 3/8	Rc 1/8	60	235.5	60	46	34	24	135	50	77
VNH2□□ ^A -15A	2-Rc 1/2	3-Rc 1/2	Rc 1/8	80	265	77	60	40	36	164.5	60	95.5
VNH3□□ ^A -20A	2-Rc 3/4	3-Rc 3/4	Rc 1/4	100	300	96	76	50	41	200	79	111
VNH4□□ ^A -25A	2-Rc1	3-Rc1	Rc 1/4	115	319.5	113	85	60	50	219	90	119

Model	J	K	L	M	N	O	P	Q	R	S	T	U	V
VNH1□□ ^A -10A	-	202.5	29	25	30	37	75	88	34	10.5	62	6 x 8	M5 x 0.8 depth 5.5
VNH2□□ ^A -15A	20	232	36	30	40	43	100	118	44.5	16	70	7 x 10	M6 x 1 depth 6
VNH3□□ ^A -20A	24	267	48	35	50	50.5	126	148	60.5	19.5	92	9 x 12	M8 x 1.25 depth 6
VNH4□□ ^A -25A	24	286.5	51	38	56	58.5	141	163	66.5	15.5	109	9 x 12	M8 x 1.25 depth 6

Precautions

Be sure to read before handling.
Refer to page 17-6-3 for Safety Instructions and Solenoid Valve Precautions.

Back Pressure of 3 Port Valve (VNH□13)

Caution

1. Ensure that back pressure of 3(B) port from VNH□13 is less than 5 MPa.

Quality of Operating Fluid

Caution

Please note that using fluids that contain foreign material (especially hard objects like glass chips), may cause damage to the valve, will reduce sealing performance, and may cause early failure.

Piping

Caution

When high temperature fluids are used, use fittings and tubing with heat resistant features. (Self-align fittings, Teflon[®] tubing, Copper tubing, etc.)

VC□

VDW

VQ

VX2

VX□

VX3

VXA

VN□

LVC

LVA

LVH

LVD

LVQ

LQ

LVN

TI/
TIL

PA

PAX

PB

Series VNH

Construction

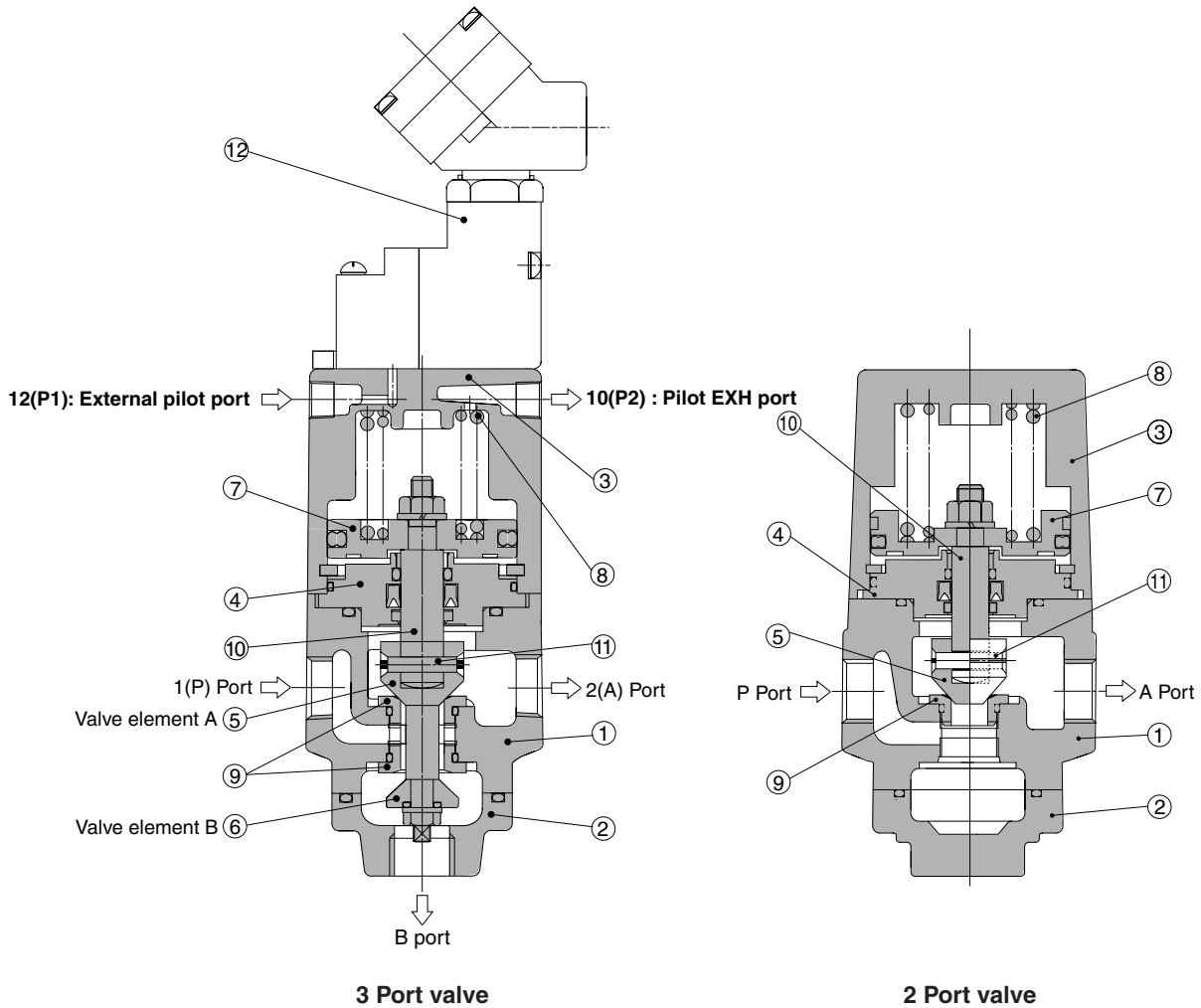

Working Principle

When the pilot operated solenoid valve ⑫ is not energized, the valve element A ⑤ connected to the piston ⑦ is closed by the return spring ⑧. Then valve element B ⑥ connected to the valve element A ⑤ is open. When the pilot operated solenoid valve ⑫ is energized, the pilot air supplied to the bottom of the piston ⑦ moves upward to open the valve element A ⑤ and closes the valve element B ⑥. Because rod ⑩ is connected to valve element A ⑤ by parallel pin ⑪. Valve element becomes free to incline and it reaches valve seat ⑨.

Component Parts

No.	Description	Material	Note
①	Body	Cast iron	Plated
②	Undercover	Cast iron	Plated
③	Cover	Aluminum alloy	
④	Plate	Iron	
⑤	Valve element A	Stainless steel	
⑥	Valve element B	Stainless steel	
⑦	Piston	Aluminum alloy	
⑧	Return spring	Piano wire	
⑨	Valve seat	Stainless steel	
⑩	Rod	Stainless steel	
⑪	Parallel pin	Stainless steel	
⑫	Pilot solenoid valve	Refer to "How to Order" in page 17-4-32.	