



High Vacuum Angle Valve
XL Series



Light weight and compact
Uniform baking temperature
High fluorine resistance
Low outgassing
Little heavy metal contamination

Series XL

High Vacuum Angle Valve

Light weight & compact

Large conductance with a small valve body.

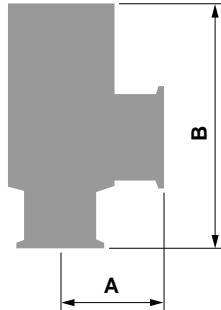

Series XLA (mm)

Model	A mm *	B mm	Weight kg (lb)	Conductance * ℓ/s
XLA-16	40	103	0.25 (0.55)	5
XLA-25	50	113	0.45 (0.99)	14
XLA-40	65	158	1.1 (2.43)	45
XLA-50	70	170	1.6 (3.53)	80
XLA-63	88	196	2.9 (6.39)	160
XLA-80	90	235	5.0 (11.02)	200

* Common to all series.

1in=25.4mm

Uniform baking temperature

Excellent thermal conductivity results in a uniform temperature for the entire valve body and a marked decrease in the condensation of gases inside the valve.

Comparison with KF25 flange

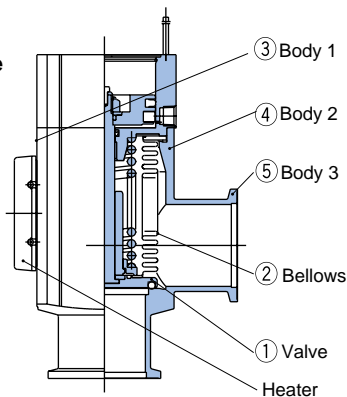

High fluorine resistance

Excellent resistance against fluorine corrosion.

Low outgassing

Low outgassing makes it possible to use a lower capacity pump and also to shorten evacuation time.

Little heavy metal contamination

The valve does not contain heavy metals such as Ni (nickel) or Cr (chrome) and a low sputtering yield also helps to minimize heavy metal contamination of semiconductor wafers.

Aluminum
(setting temp.: 120°C [248°F])

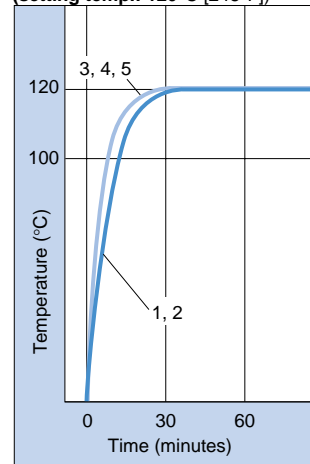

Stainless steel
(setting temp.: 120°C [248°F])

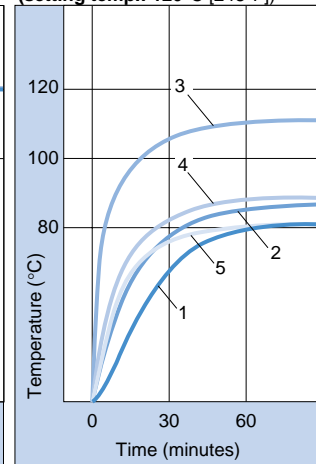

$^{\circ}\text{F}=(1.8\times^{\circ}\text{C})+32^{\circ}$

High Vacuum Angle Valve XL Series Features

XLA/XLAV (Bellows seal, Single acting)

- Bellows type is particulate free and completely cleaned.
- Pressure balance mechanism allows unrestricted exhaust direction.

XLG/XLGV (Bellows Seal, Double acting)

- Bellows type is particulate free and completely cleaned.
- Pressure balance mechanism allows unrestricted exhaust direction.
- Overtravel mechanism maintains constant O-ring compression (size 50, 63, 80).

XLG/XLGV (O-ring seal, Single acting)

- Low gas entrainment with employment of O-ring seal system.
- High speed response and long service life.
- Particulates are reduced through special surface treatment of shaft seal.

XLG/XLGV (O-ring seal, Double acting)

- Low gas entrainment with employment of O-ring seal system.

XLG/XLGV (O-ring seal, Double acting) continued

- High speed response and long service life.
- Overtravel mechanism maintains constant O-ring compression (size 50, 63, 80).
- Particulates are reduced through special surface treatment of shaft seal.

XLD/XLDV (2 stage control, Single acting)

- Initial exhaust valve and main exhaust valve have been integrated (2 stage flow control valve).
- Makes compact system design and reduced piping possible.
- Minimizes particulates by eliminating turbulence during exhaust.

- Prevents pump overload.

- Initial exhaust valve flow is adjustable and adjustment can be locked.

XLH (Bellows seal, Manual operation)

- Bellows type is particulate free and completely cleaned.
- Pressure balance mechanism allows unrestricted exhaust direction.

XLH (Bellows seal, Manual operation) continued

- Low actuation torque (0.5N·m or less).
- Spring provides standard sealing load.
- Handle height is the same when valve is open or closed.
- Indicator to confirm opening and closing of valve is standard equipment.

XLS (Bellows pressure balance, Normally closed solenoid)

- Particulates are reduced because there are no sliding metal parts.
- Pressure balance mechanism allows unrestricted exhaust direction.
- A control power supply circuit for solenoid valve drive has been made standard.
- Can be used in portable equipment since air for drive is not necessary.

XSA (Direct solenoid operation)

- Solenoid valve with metal seal fittings (VCR®/Swagelok®)
- Particulates are reduced because there are no sliding metal parts.
- Improved reverse pressure performance.

High Vacuum Angle Valve

Actuation	Application	Shaft seal system	Models	Valve type	Operating pressure Pa	Leakage Pa m ³ /sec		Service life (Million cycles)	Flange size						Options										
						Internal	External		16	25	40	50	63	80	Switch	Heater	Indicator	High temp. specification							
Air operated	Particulate free completely cleaned	Bellows Seal	XLA	Single acting (N.C.)	10 ⁵ to 10 ⁻⁶	10 ⁻¹⁰	10 ⁻¹¹	2	●	●	●	●	●	●	●	●	●	●	●	●	P.4 to P.7				
			XLAV (With solenoid valve)						●	●	●	●	●	●	●	●	●	●	●	●		●	●	●	
			XLC	Double acting					●	●	●	●	●	●	●	●	●	●	●	●	●	●	●	●	P.8 to P.11
			XLCV (With solenoid valve)						●	●	●	●	●	●	●	●	●	●	●	●	●	●	●	●	
	High speed operation High volume operation	O-ring Seal	XLF	Single acting (N.C.)	2 x 10 ⁵ to 10 ⁻⁵	10 ⁻¹⁰	10 ⁻¹⁰	3 Size (16, 25, 40)	●	●	●	●	●	●	●	●	●	●	●	●	P.12 to P.15				
			XLFV (With solenoid valve)						●	●	●	●	●	●	●	●	●	●	●	●		●	●	●	
			XLG	Double acting					●	●	●	●	●	●	●	●	●	●	●	●	●	●	●	●	P.16 to P.19
			XLGV (With solenoid valve)						●	●	●	●	●	●	●	●	●	●	●	●	●	●	●	●	
	Reduces particulates Eliminates pump over loads	Bellows, O-ring Seal	XLD	Single acting (N.C.)	10 ⁵ to 10 ⁻⁶	10 ⁻¹⁰	10 ⁻¹¹	2	●	●	●	●	●	●	●	●	●	●	Standard	●	P.20 to P.25				
			XLDV (With solenoid valve)						●	●	●	●	●	●	●	●	●	●	●	●		●	Standard	●	
Manual	For portable equipment not requiring air Particulate free completely cleaned	Bellows Seal	XLH	Manual	10 ⁵ to 10 ⁻⁶	10 ⁻¹⁰	10 ⁻¹¹	0.1	●	●	●	●	●	●	●	●	●	●	Standard	Standard	P.26, P.27				
	Electromagnetic								For portable equipment not requiring air	(Bellows Balance)	XLS	Single acting (N.C.)	2 x 10 ⁵ to 10 ⁻⁶	10 ⁻⁸	10 ⁻¹¹	0.5	●	●	●	●		●	●	●	●

* Heater and high temperature specifications are not available with switches.
 1Pa=0.145 x 10⁻³psi
 1MPa=145psi

Straight Solenoid Valve (with Metallic Seal Fitting)



Model	Valve type	Piping size	Orifice mmø	Effective sectional area mm ²	Operating pressure		Leakage Pa m ³ /sec			Service life million cycles	
					Differential pressure MPa	Port A Pa	Internal	External	Fitting		
XSA1-12	Direct solenoid operation (N.C.)	1/4	2	3	10 ⁻⁶	10 ⁻⁹	10 ⁻¹¹	VCR [®] 10 ⁻¹¹	2	P.32 to P.34	
XSA1-22			3	6							0.3
XSA2-22											1.0
XSA2-32											0.3
XSA3-32			4.5	11							0.8
XSA3-43											0.3
		3/8	6	19				SWJ [®] 10 ⁻¹⁰			

* Differential Pressure: Indicates the maximum operable pressure difference between port P and port A. In the case of 0.8MPa, when port A is a vacuum, port P can be pressurized to 0.8MPa (7kgf/cm²G).
 * VCR[®] Fitting and Swagelok[®] Fitting are registered trade marks of the Cajon Company and the Crawford Fitting Company Inc. respectively.

How to Order

XLA — **16** — **F9N**

High vacuum angle valve
(Normally closed, bellows seal, air operated type)

Flange size

16
25
40
50
63
80

Flange type

Symbol	Type	Applicable flange size
Nil	KF(NW)	16, 25, 40, 50, 63, 80
D	K(DN)	63, 80

Indicator/Actuation port direction

Symbol	Description
Nil	Without indicator/Flange side
A	With indicator/Flange side
F	With indicator/Left flange surface
G	With indicator/Rear flange surface
J	With indicator/Right flange surface
K	Without indicator/Left flange surface
L	Without indicator/Rear flange surface
M	Without indicator/Right flange surface

Note) Actuation port direction
(Example) Left flange surface: Indicates that the direction of the actuation port is to the left side when the flange surface is viewed from the front.

**Switch quantity/
Mounting position**

Symbol	Quantity	Mounting position
Nil	—	—
A	2pcs.	Valve open/closed
B	1pc.	Valve open
C	1pc.	Valve closed

Auto switch type

Nil	Without auto switch (without built-in magnet)
-----	---

Solid state auto switches

F9N	D-F9N
F9P	D-F9P
F9B	D-F9B

Note 1) The standard lead wire length is 0.5m.
For 3m, "L" is added at the end of the part number.

(Example) F9NL: D-F9NL

Note 2) An auto switch should be secured against a stopper in the auto switch groove for detection of valve opening, or secured against a stopper or the valve body (depending on the valve size) for detection of valve closing.

Temperature specifications/Heater

Symbol	Temp. range	Heater
Nil	5 to 60°C (41 to 140°F)	None
High temp. type	H0	None
	H1	With heater for 80°C (176°F)
	H2	With heater for 100°C (212°F)
	H3	With heater for 120°C (248°F)

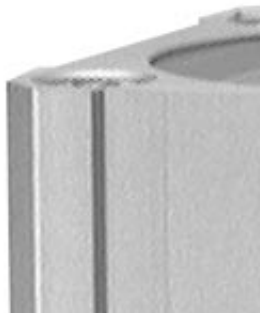

XLA

Option specifications/Combination table

Option specifications	Symbol	Model					
		XLA-16	XLA-25	XLA-40	XLA-50	XLA-63	XLA-80
Indicator	A	•	•	•	•	•	•
High temp. type	Without heater	H0	•	•	•	•	•
	With heater for 80°C (176°F)	H1	—	•	•	•	•
	With heater for 100°C (212°F)	H2	—	—	•	•	•
	With heater for 120°C (248°F)	H3	—	•	•	•	•

Note) Auto switches cannot be mounted in the case of high temperature types.

How to Order

XLAV — **16** **F** — **F9N** — **1** **G**

High vacuum angle valve
 (Normally closed, bellows seal,
 air operated type
 with solenoid valve)

Flange size

16
25
40
50
63
80

Flange type

Symbol	Type	Applicable flange size
Nil	KF(NW)	16, 25, 40, 50, 63, 80
D	K(DN)	63, 80

Solenoid valve/Indicator direction

F	With indicator/Left flange surface
G	With indicator/Rear flange surface
J	With indicator/Right flange surface
K	Without indicator/Left flange surface
L	Without indicator/Rear flange surface
M	Without indicator/Right flange surface

Note) Actuation port direction
 (Example) Left flange surface: Indicates that the direction of the actuation port is to the left side when the flange surface is viewed from the front.

Auto switch type

Nil	Without auto switch (without built-in magnet)
-----	---

Solid state auto switches

F9N	D-F9N
F9P	D-F9P
F9B	D-F9B

Note 1) The standard lead wire length is 0.5m.
 For 3m, "L" is added at the end of the part number.
 (Example) F9NL: D-F9NL

Note 2) An auto switch should be secured against a stopper in the auto switch groove for detection of valve opening, or secured against a stopper or the valve body (depending on the valve size) for detection of valve closing.



XLAV

Light/Surge voltage suppressor

Nil	None
S	With surge voltage suppressor
Z	With light/surge voltage suppressor
U	With light/surge voltage suppressor (non-polar type)

* The S type is not available for AC.
 * The U type is DC only.

Electrical entry

G	Grommet (lead wire length 300mm)
H	Grommet (lead wire length 600mm)
L	L type plug connector
M	M type plug connector

Rated voltage

1	100VAC, 50/60Hz
2	200VAC, 50/60Hz
3	110VAC, 50/60Hz
4	220VAC, 50/60Hz
5	24VDC
6	12VDC

Switch quantity/Mounting position

Symbol	Quantity	Mounting position
Nil	—	—
A	2pcs.	Valve open/closed
B	1pc.	Valve open
C	1pc.	valve closed

Note 1) Option specifications/Combinations

This model has indicator, auto switch and K(DN) flange options, but high temperature/heater options are not available.

Note 2) Solenoid valves

XLAV-16, 25, 40, 50: SYJ319 XLAV-63, 80: SYJ519

Example) SYJ319-1GS, etc.

For further details on solenoid valves, refer to the SMC solenoid valve catalog "SYJ 300, 500, 700" (E143-B).

Note 3) Solenoid valves are shipped facing downward (flange side), but can be rotated to face upward.

Specifications

Model	XLA(V)-16	XLA(V)-25	XLA(V)-40	XLA(V)-50	XLA(V)-63	XLA(V)-80	
Valve type	Normally closed (pressurize to open, spring seal)						
Fluid	Non-corrosive gas for aluminum alloy (A6063) and SUS304/316						
Operating temperature °C	XLA	5 to 60°C (41 to 140°F) [high temperature type: 5 to 150°C (41 to 302°F)]					
	XLAV	5 to 50°C (41 to 122°F)					
Operating pressure Pa {Torr}	Atmospheric pressure to 1×10^{-6} {760 to 7.5×10^{-9} }						
Conductance ds <small>Note 1)</small>	5	14	45	80	160	200	
Leakage $\text{Pa m}^3/\text{s}$ {Torr ds }	Internal	1.3×10^{-10} { 1×10^{-9} } at ordinary temperatures, excluding gas transmission					
	External	1.3×10^{-11} { 1×10^{-10} } at ordinary temperatures, excluding gas transmission					
Operating time s <small>Note 2)</small>	0.05	0.1	0.21	0.24	0.26	0.28	
Flange type	KF (NW)			KF (NW), K (DN)			
Principle materials	Body: Aluminum alloy Bellows: Stainless steel Seal: FKM (fluoro rubber)						
Surface treatment	Exterior: Hard anodized Interior: Machined for clean environment						
Actuation pressure MPa	0.4 to 0.7 (58 to 101psi)						
Actuation port size	XLA	M5 (10-32 nominal)		Rc(PT) 1/8			
	XLAV	M5 (10-32 nominal) Ports P, R1/R2			Rc(PT) 1/8(Port P): M5(10-32 nominal) Ports R1/R2		
Actuating solenoid valve recommended Cv factor (XLC)	0.05≤	0.06≤	0.09≤	0.11≤	0.3≤	0.35≤	
Service life (Million cycles)	2						
Weight kg (lb)	XLA	0.25 (0.55)	0.46 (1.01)	1.1 (2.43)	1.6 (3.52)	2.9 (6.39)	5.0 (11.02)
	XLAV	0.29 (0.64)	0.49 (1.08)	1.14 (2.51)	1.64 (3.61)	2.96 (6.52)	5.06 (11.16)

Note 1) Conductance is the same as that of an elbow with the same dimensions.

Note 2) The time required for 90% valve movement when an actuation pressure of 0.5MPa {72psi} is applied. There is a difference of about 20% in this value at the upper and lower pressure limits.

Note 3) For valve heater specifications, refer to "Common Option Specifications, [1] Heaters" on page 37.

Construction /Operation

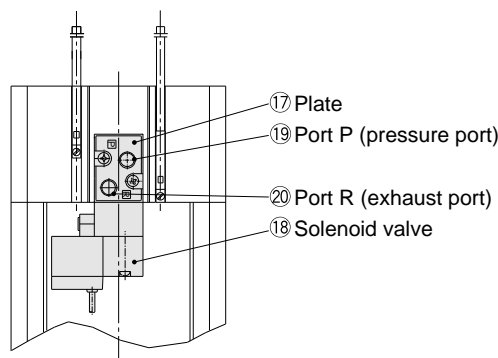

With solenoid valve

Options

- ④ Auto switch: The magnet (10) actuates the auto switch (4) indicating the position of the integrated valve (15) and piston (8). With 2 auto switches, the open and closed positions are detected, and with 1 auto switch, either the open or closed position is detected. Auto switches are applicable at ordinary temperatures only 5 to 60°C (41 to 140°F).
- ⑤ Heater: Simple heating is performed using thermistors. The valve body can be heated to approximately 80, 100 or 120°C (176, 212 or 248°F) depending on the heater option and the valve size. The type and number of thermistors to be used will vary depending upon size and setting temperature. In the case of high temperature specifications, the bonnet assembly (1) is a heat resistant structure.
- ⑥ Indicator: When the valve is open, an orange marker about 1mm in height appears in the center of the name plate (16).

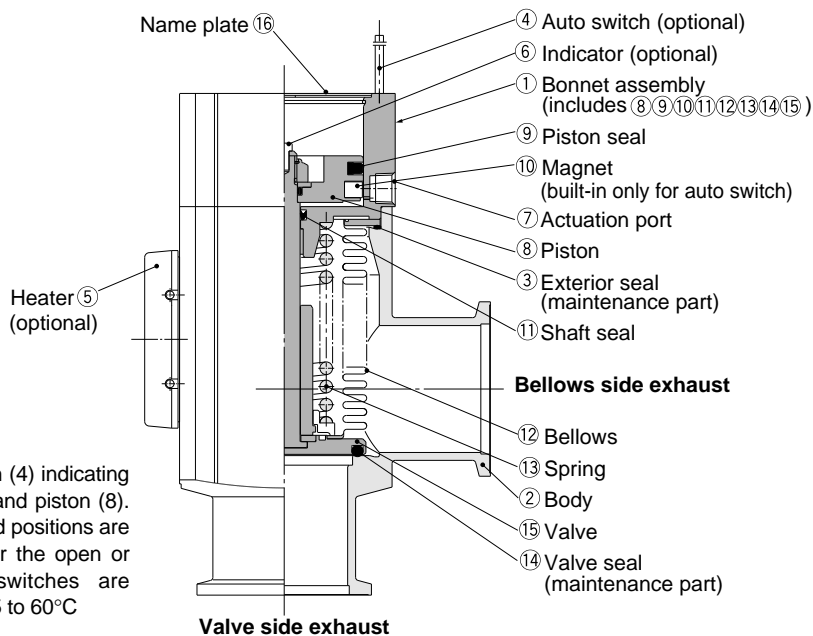

Operation principle

By applying pressure from the actuation port (7), the piston (8), which is sealed by the shaft seal (11) and the piston seal (9), overcomes the force of the spring (13), and the valve (15) opens. With the exhaust of air pressure, the valve (15) is closed by the force of the spring (13) and is sealed by the valve seal (14). In the case of the XLAV, port P(19) is normally pressurized, and the valve (15) opens when the solenoid valve (18) is turned ON and closes when it is turned OFF. Operation is the same as that of the XLA.

Dimensions (mm)

1 in = 25.4mm

XLA/Air operated type

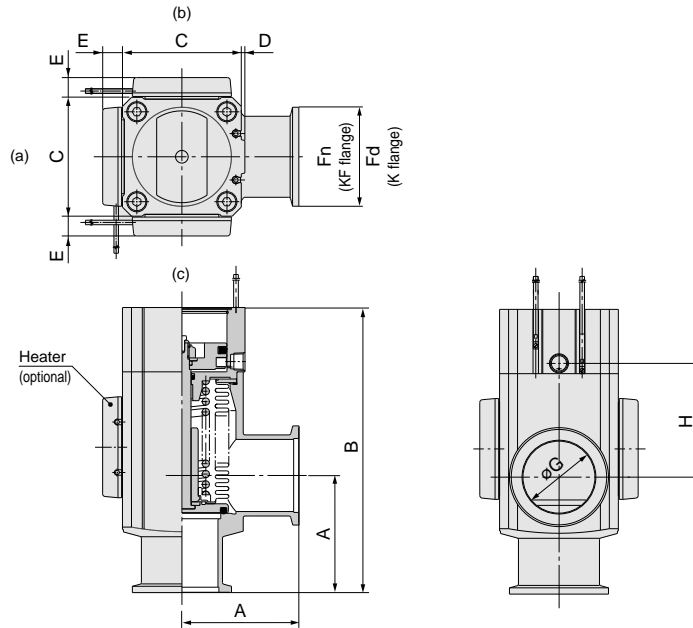

Model	A	B	C	D	E ^{Note 1)}	Fn	Fd	G	H
XLA-16	40	103	38	1	—	30	—	17	40
XLA-25	50	113	48	1	12	40	—	26	39
XLA-40	65	158	66	2	11	55	—	41	63
XLA-50	70	170	79	2	11	75	—	52	68
XLA-63	88	196	100	3	11	87	95	70	69
XLA-80	90	235	117	3	11	114	110	83	96

Note 1) Dimension E applies when heater option is included. (lead wire length: approx. 1m)

Note 2) (a), (b) and (c) in the above drawing indicate heater mounting positions.

Moreover, heater mounting positions will differ depending on the type of heater.

For further details, refer to mounting positions under Replacement heaters/Part Nos. on page 46.

XLAV/With solenoid valve

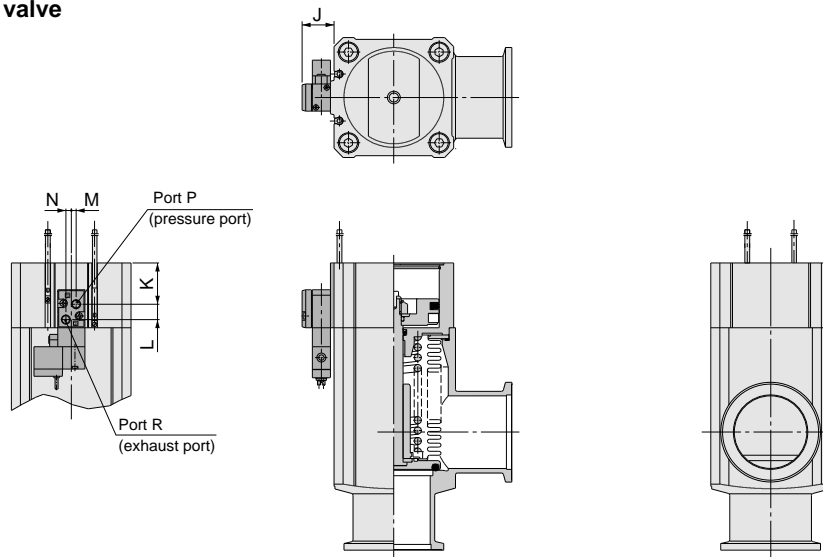

Model	J	K	L	M	N
XLAV-16	16.5	13	8.5	3	3
XLAV-25	16.5	14	8.5	3	3
XLAV-40	17.5	23	8.5	3	3
XLAV-50	17.5	25	8.5	3	3
XLAV-63	29	29	12	4	2
XLAV-80	29	39	12	4	2

* Other dimensions are the same as XLA.

How to Order

XLC — 16 — — — — F9N —

High vacuum angle valve
(Double acting, bellows seal, air operated type)

Flange size

16
25
40
50
63
80

Flange type

Symbol	Type	Applicable flange size
Nil	KF(NW)	16, 25, 40, 50, 63, 80
D	K(DN)	63, 80

Actuation port direction

Nil	Flange side
K	Left flange surface
L	Rear flange surface
M	Right flange surface

Note) Actuation port direction
(Example) Left flange surface:
Indicates that the direction of the actuation port is to the left side when the flange surface is viewed from the front.



XLC

Switch quantity/Mounting position

Symbol	Quantity	Mounting position
Nil	—	—
A	2pcs.	Valve open/closed
B	1pc.	Valve open
C	1pc.	Valve closed

Auto switch type

Nil	Without auto switch (without built-in magnet)
-----	---

Solid state auto switches

F9N	D-F9N
F9P	D-F9P
F9B	D-F9B

Note 1) The standard lead wire length is 0.5m.
For 3m, "L" is added at the end of the part number.
(Example) F9NL: D-F9NL

Note 2) An auto switch should be secured against a stopper in the auto switch groove for detection of valve opening, or secured against a stopper or the valve body (depending on the valve size) for detection of valve closing.

Temperature specifications/Heater

Symbol	Temp. range	Heater
Nil	5 to 60°C (41 to 140°F)	None
High temp. type	H0	None
	H1	With heater for 80°C (176°F)
	H2	With heater for 100°C (212°F)
	H3	With heater for 120°C (248°F)

High temperature type combination table

High temperature specifications	Symbol	Model					
		XLC-16	XLC-25	XLC-40	XLC-50	XLC-63	XLC-80
Without heater	H0	•	•	•	•	•	•
With heater for 80° (176°F)	H1	—	•	•	•	•	•
With heater for 100°C (212°F)	H2	—	—	•	•	•	•
With heater for 120°C (248°F)	H3	—	•	•	•	•	•

Note) Auto switches cannot be mounted in the case of high temperature types.

How to Order

XLCV — **16** — **K** — **F9N** — **1** — **G**

High vacuum angle valve

(Double acting, bellows seal, air operated type with solenoid valve)

Flange size

16
25
40
50
63
80

Flange type

Symbol	Type	Applicable flange size
Nil	KF(NW)	16, 25, 40, 50, 63, 80
D	K(DN)	63, 80

Solenoid valve direction

K	Left flange surface
L	Rear flange surface
M	Right flange surface

Note) Solenoid valve direction (Example) Left flange surface: Indicates that the direction of the solenoid valve is to the left side when the flange surface is viewed from the front.

Auto switch type

Symbol	Without auto switch (without built-in magnet)
Nil	Without auto switch (without built-in magnet)
Solid state auto switches	
F9N	D-F9N
F9P	D-F9P
F9B	D-F9B

Note 1) The standard lead wire length is 0.5m. For 3m, "L" is added at the end of the part number. (Example) F9NL: D-F9NL

Note 2) An auto switch should be secured against a stopper in the auto switch groove for detection of valve opening, or secured against a stopper or the valve body (depending on the valve size) for detection of valve closing.

Light/Surge voltage suppressor

Nil	None
S	With surge voltage suppressor
Z	With light/surge voltage suppressor
U	With light/surge voltage suppressor (non-polar type)

* The S type is not available for AC.
* The U type is DC only.

Electrical entry

G	Grommet (lead wire length 300mm)
H	Grommet (lead wire length 600mm)
L	L type plug connector
M	M type plug connector

Solenoid valve action

Nil	2 position single
W	2 position double

Rated voltage

1	100VAC, 50/60Hz
2	200VAC, 50/60Hz
3	110VAC, 50/60Hz
4	220VAC, 50/60Hz
5	24VDC
6	12VDC

Switch quantity/Mounting position

Symbol	Quantity	Mounting position
Nil	—	—
A	2pcs.	Valve open/closed
B	1pc.	Valve open
C	1pc.	Valve closed



XLCV

Note 1) Option specifications/Combinations

This model has auto switch and K(DN) flange options, but high temperature/heater options are not available.

Note 2) Solenoid valves

2 position single : XLCV-16, 25, 40, 50 : SYJ3190 XLCV-63, 80 : SYJ5190

2 position double: XLCV-16, 25, 40, 50 : SYJ3290 XLCV-63, 80 : SYJ5290

Examples) SYJ3190-1GS SYJ3290-1GS

For further details on solenoid valves, refer to the SMC solenoid valve catalog "SYJ 3000, 5000, 7000" (N237).

Note 3) The direction of solenoid valve coils cannot be changed.

Specifications

Model	XLC(V)-16	XLC(V)-25	XLC(V)-40	XLC(V)-50	XLC(V)-63	XLC(V)-80	
Valve type	Double acting (dual operation), pressurize to open/close						
Fluid	Non-corrosive gas for aluminum alloy (A6063) and SUS304/316						
Operating temperature °C	XLC	5 to 60°C (41 to 140°F) [high temperature type: 5 to 150°C (41 to 302°F)]					
	XLCV	5 to 50°C (41 to 122°F)					
Operating pressure Pa {Torr}	Atmospheric pressure to 1×10^{-6} {760 to 7.5×10^{-9} }						
Conductance d/s ^{Note 1)}	5	14	45	80	160	200	
Leakage $\text{Pa m}^3/\text{s}$ {Torr d/s}	Internal	1.3×10^{-10} { 1×10^{-9} } at ordinary temperatures, excluding gas permeation					
	External	1.3×10^{-11} { 1×10^{-10} } at ordinary temperatures, excluding gas permeation					
Operating time s ^{Note 2)}	0.08	0.15	0.35	0.4	0.54	0.7	
Flange type	KF (NW)			KF (NW), K (DN)			
Principle materials	Body: Aluminum alloy Bellows: Stainless steel Seal: FKM (fluoro rubber)						
Surface treatment	Exterior: Hard anodized Interior: Machined for clean environment						
Actuation pressure MPa	0.3 to 0.6 {43 to 87psi}						
Actuation port size	XLC	M5 (10-32 nominal)		Rc(PT) 1/8			
	XLCV	M5 (10-32 nominal) Ports P, R ₁ /R ₂			Rc(PT) 1/8(Port P): M5(10-32 nominal) Ports R ₁ /R ₂		
Actuating solenoid valve recommended Cv factor (XLC)	0.05≤	0.06≤	0.09≤	0.11≤	0.3≤	0.35≤	
Service life (Million cycles)	2						
Weight kg (lb)	XLC	0.28 (0.62)	0.46 (1.01)	1.1 (2.43)	1.7 (3.75)	3.1 (6.83)	5.1 (11.24)
	XLCV	0.32 (0.71)	0.5 (1.10)	1.15 (2.54)	1.74 (3.84)	3.16 (6.97)	5.16 (11.38)

Note 1) Conductance is the same as that of an elbow with the same dimensions.

Note 2) The time required for 90% valve movement when an actuation pressure of 0.5MPa {72psi} is applied. There is a difference of about 20% in this value at the upper and lower pressure limits.

Note 3) For valve heater specifications, refer to "Common Option Specifications, [1] Heaters" on page 37.

Construction/Operation

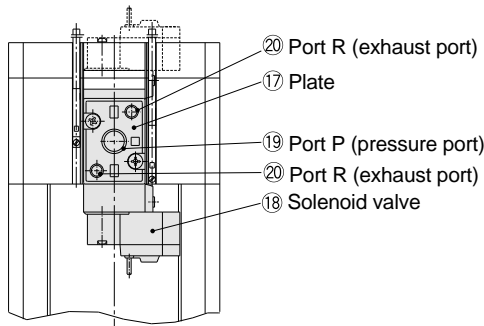

With solenoid valve

Operating principle

By applying pressure from the actuating port [1]-(7), the piston (8), sealed by the shaft seal (11) and the piston seal (9), is operated opening the valve. (actuation port [2]-(7) is released)

Conversely, by applying pressure to actuation port [2]-(7), the piston (8), sealed by the cylinder seal (13) and the piston seal (9), is operated closing the valve (15) which is sealed by the valve seal (14). (actuation port [1]-(7) is released)

In the case of the XLCV, port P (19) is normally pressurized, and the valve (15) opens when the solenoid valve (18) is turned ON, and closes when it is turned OFF. Moreover, in the case of a double solenoid, the valve moves to the side where the solenoid valve (18) is turned ON. Operation is the same as that of the XLC.

For sizes 50, 63 and 80, the valve is sealed with a standard load by means of an overrun mechanism.

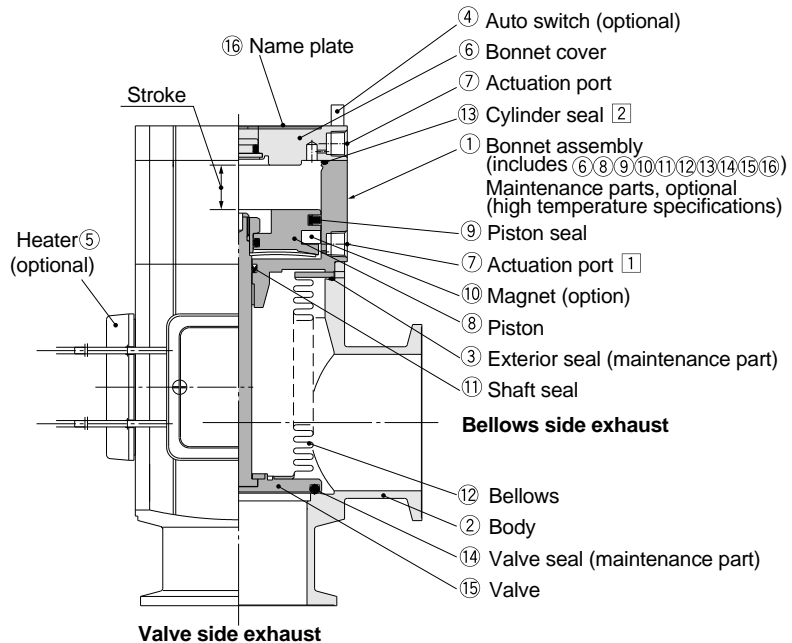

Options

- ④ Auto switch: The magnet (10) actuates the auto switch (4) indicating the position of the integrated valve (15) and piston (8). With 2 auto switches, the open and closed positions are detected, and with 1 auto switch, either the open or closed position is detected. Auto switches are applicable at ordinary temperatures only 5 to 60°C (41° to 140°F).
- ⑤ Heater: Simple heating is performed using thermistors. The valve body can be heated to approximately 80, 100 or 120°C (176, 212, 248°F), depending on the heater option and the valve size. The type and number of thermistors to be used will vary depending upon size and setting temperature. In the case of high temperature specifications, the bonnet assembly (1) is a heat resistant structure.

Dimensions (mm)

1in = 25.4mm

XLC/Air operated type

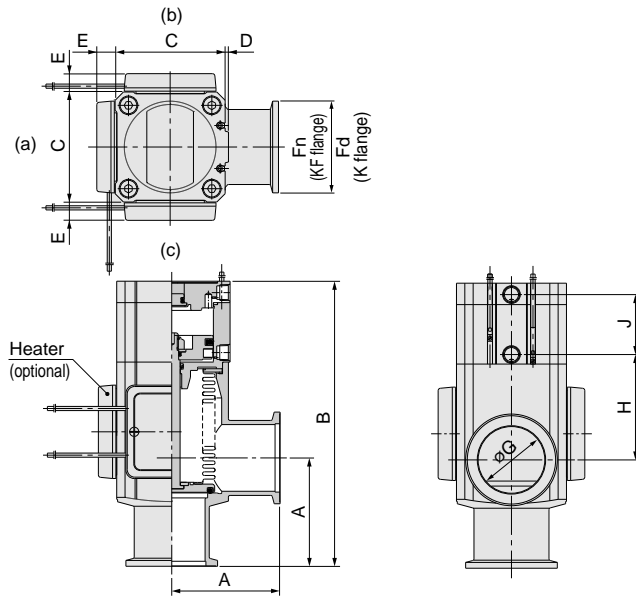

Model	A	B	C	D	E ^{Note 1)}	Fn	Fd	G	H	J
XLC-16	40	110	38	1	—	30	—	17	40	26
XLC-25	50	120	48	1	12	40	—	26	39	28
XLC-40	65	171	66	2	11	55	—	41	63	36
XLC-50	70	183	79	2	11	75	—	52	68	38
XLC-63	88	209	100	3	11	87	95	70	69	45
XLC-80	90	250	117	3	11	114	110	83	96	56

Note 1) Dimension E applies when heater option is included. (lead wire length: approx. 1m)

Note 2) (a), (b) and (c) in the above drawing indicate heater mounting positions.

Moreover, heater mounting positions will differ depending on the type of heater.

For further details, refer to mounting positions under Replacement heaters/Part Nos. on page 46.

XLCV/With solenoid valve

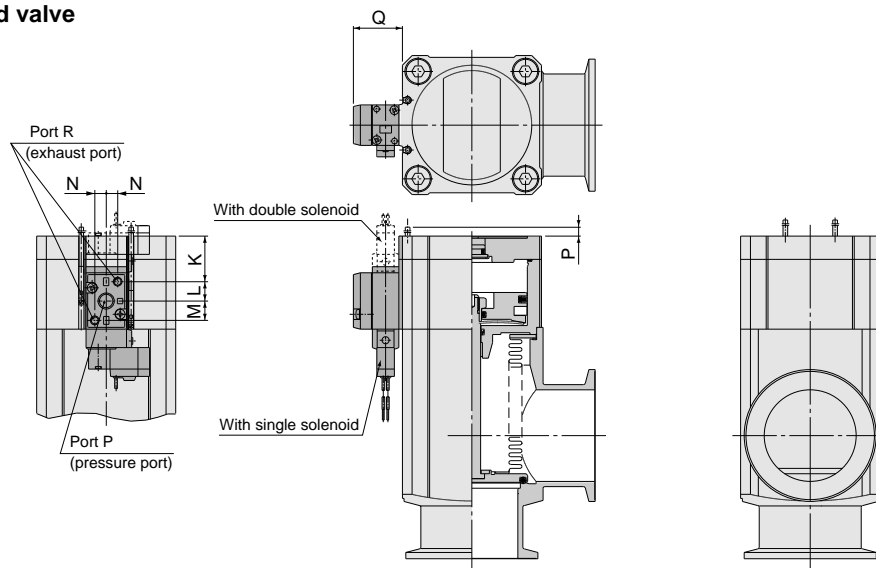

Model	K	L	M	N	P	Q
XLCV-16	14	9	6.5	3	17	16.5
XLCV-25	16	9	6.5	3	15	16.5
XLCV-40	29	9	6.5	3	2	17.5
XLCV-50	42	9	6.5	3	6	17.5
XLCV-63	32	11	11	6.5	—	29
XLCV-80	45	11	11	6.5	—	29

* Other dimensions are the same as XLA.

How to Order



High vacuum angle valve
(Normally closed, O-ring seal,
air operated type)

Flange size

16
25
40
50
63
80

Flange type

Symbol	Type	Applicable flange size
Nil	KF(NW)	16, 25, 40, 50, 63, 80
D	K(DN)	63, 80

Indicator/Actuation port direction

Symbol	Direction
Nil	Without indicator/Flange side
A	With indicator/Flange side
F	With indicator/Left flange surface
G	With indicator/Rear flange surface
J	With indicator/Right flange surface
K	Without indicator/Left flange surface
L	Without indicator/Rear flange surface
M	Without indicator/Right flange surface

Note) Actuation port direction
(Example) Left flange surface: Indicates that the direction of the actuation port is to the left side when the flange surface is viewed from the front.

Switch quantity/Mounting position

Symbol	Quantity	Mounting position
Nil	—	—
A	2pcs.	Valve open/closed
B	1pc.	Valve open
C	1pc.	Valve closed

Auto switch type

Nil	Without auto switch (without built-in magnet)
-----	---

Solid state auto switches

F9N	D-F9N
F9P	D-F9P
F9B	D-F9B

Note 1) The standard lead wire length is 0.5m.
For 3m, "L" is added at the end of the part number.
(Example) F9NL: D-F9NL

Note 2) An auto switch should be secured against a stopper in the auto switch groove for detection of valve opening, or secured against a stopper or the valve body (depending on the valve size) for detection of valve closing.

Temperature specifications/Heater

Symbol	Temp. range	Heater
Nil	5 to 60°C (41 to 140°F)	None
High temp. type	H0	None
	H1	With heater for 80°C (176°F)
	H2	With heater for 100°C (212°F)
	H3	With heater for 120°C (248°F)



XLF

Option specifications/Combination table

Option specifications	Symbol	Model					
		XLF-16	XLF-25	XLF-40	XLF-50	XLF-63	XLF-80
Indicator	A	•	•	•	•	•	•
High temp. type	Without heater	•	•	•	•	•	•
	With heater for 80°C (176°F)	H1	—	•	•	•	•
	With heater for 100°C (212°F)	H2	—	—	•	•	•
	With heater for 120°C (248°F)	H3	—	•	•	•	•

Note) Auto switches cannot be mounted in the case of high temperature types.

How to Order

XLFV — **16** — **F** — **F9N** — **1** **G**

High vacuum angle valve
(Normally closed, O-ring seal,
air operated type
with solenoid valve)

Flange size

16
25
40
50
63
80

Flange type

Symbol	Type	Applicable flange size
Nil	KF(NW)	16, 25, 40, 50, 63, 80
D	K(DN)	63, 80

Solenoid valve/Indicator direction

F	With indicator/Left flange surface
G	With indicator/Rear flange surface
J	With indicator/Right flange surface
K	Without indicator/Left flange surface
L	Without indicator/Rear flange surface
M	Without indicator/Right flange surface

Note) Actuation port direction
(Example) Left flange surface: Indicates that the direction of the actuation port is to the left side when the flange surface is viewed from the front.

Auto switch type

Nil	Without auto switch (without built-in magnet)
-----	---

Solid state auto switches

F9N	D-F9N
F9P	D-F9P
F9B	D-F9B

Note 1) The standard lead wire length is 0.5m.
For 3m, "L" is added at the end of the part number.
(Example) F9NL: D-F9NL

Note 2) An auto switch should be secured against a stopper in the auto switch groove for detection of valve opening, or secured against a stopper or the valve body (depending on the valve size) for detection of valve closing.

Note 1) Option specifications/Combinations

This model has indicator, auto switch and K(DN) flange options, but high temperature/heater options are not available.

Note 2) Solenoid valves

XLFV-16, 25, 40: SYJ319 XLFV-50, 63, 80: SYJ519 Example) SYJ319-1GS

For further details on solenoid valves, refer to the SMC solenoid valve catalog "SYJ300, 500, 700" (N220).

Note 3) Solenoid valves are shipped facing downward (flange side), but can be rotated to face upward.

Light/Surge voltage suppressor

Nil	None
S	With surge voltage suppressor
Z	With light/surge voltage suppressor
U	With light/surge voltage suppressor (non-polar type)

* The S type is not available for AC.
* The U type is DC only.

Electrical entry

G	Grommet (lead wire length 300mm)
H	Grommet (lead wire length 600mm)
L	L type plug connector
M	M type plug connector

Rated voltage

1	100VAC, 50/60Hz
2	200VAC, 50/60Hz
3	110VAC, 50/60Hz
4	220VAC, 50/60Hz
5	24VDC
6	12VDC

Switch quantity/Mounting position

Symbol	Quantity	Mounting position
Nil	—	—
A	2pcs.	Valve open/closed
B	1pc.	Valve open
C	1pc.	Valve closed



XLFV

Specifications

Model		XLF(V)-16	XLF(V)-25	XLF(V)-40	XLF(V)-50	XLF(V)-63	XLF(V)-80	
Valve type		Normally closed (pressurize to open, spring seal)						
Fluid		Non-corrosive gas for aluminum alloy (A6063) and SUS304/316						
Operating temperature °C	XLF	5 to 60°C (41 to 140°F) [high temperature type: 5 to 150°C (41 to 302°F)]						
	XLFV	5 to 50°C (41 to 122°F)						
Operating pressure Pa {Torr}		Atmospheric pressure to 1×10^{-6} {760 to 7.5×10^{-9} }						
Conductance d/s ^{Note 1)}		5	14	45	80	160	200	
Leakage $\text{Pa m}^3/\text{s}$ {Torr d/s}	Internal	1.3×10^{-10} { 1×10^{-9} } at ordinary temperatures, excluding gas transmission						
	External	1.3×10^{-11} { 1×10^{-10} } at ordinary temperatures, excluding gas transmission						
Operating time ms ^{Note 2)}	XLF	30	35	40	45	65	85	
	XLFV	30	35	60	60	100	130	
Flange type		KF (NW)			KF (NW), K (DN)			
Principle materials		Body: Aluminum alloy Bellows: Stainless steel Seal: FKM (fluoro rubber)						
Surface treatment		Exterior: Hard anodized Interior: Machined for clean environment						
Actuation pressure MPa		0.4 to 0.7 (58 to 101psi)						
Actuation port size	XLF	M5 (10-32 nominal)			Rc(PT) 1/8			
	XLFV	M5 (10-32 nominal) Ports P, R				Rc(PT) 1/8(Port P): M5(10-32 nominal) (Port)		
Actuating solenoid valve recommended Cv factor (XLF)		$0.06 \leq$	$0.09 \leq$	$0.11 \leq$	$0.15 \leq$	$0.4 \leq$	$0.5 \leq$	
Service life (Million cycles)		3					2	
Weight kg (lb)	XLF	0.25 (0.55)	0.45 (0.99)	1.1 (2.43)	1.6 (3.52)	3.0 (6.61)	4.8 (10.58)	
	XLFV	0.29 (0.64)	0.49 (1.08)	1.14 (2.51)	1.66 (3.65)	3.06 (6.75)	4.86 (10.72)	

Note 1) Conductance is represented by the value of an elbow with the same dimensions.

Note 2) The operating time with no solenoid valve (XLF) is the same value as the case of the solenoid valve piped directly to the bonnet, where the actuation pressure is 0.5MPa (72psi). The operating time becomes faster under high pressure.

Note 3) For valve heater specifications, refer to "Common Option Specifications, [1] Heaters" on page 37.

Construction/Operation

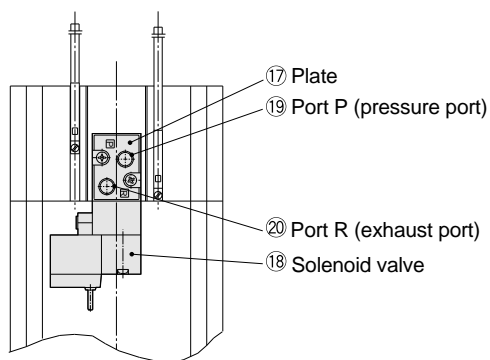

With solenoid valve

Operating principle

By applying pressure from the actuation port (7), the piston (8), which is sealed by the shaft seal (11) and the piston seal (9), overcomes the force of the spring (13), and the valve (15) opens.

With the exhaust of air pressure, the valve (15) is closed by the force of the spring (13) and is sealed by the valve seal (14).

In the case of the XLFV, port P (19) is normally pressurized, and the valve (15) opens when the solenoid valve (18) is turned ON, and closes when it is turned OFF. Operation is the same as that of the XLF.

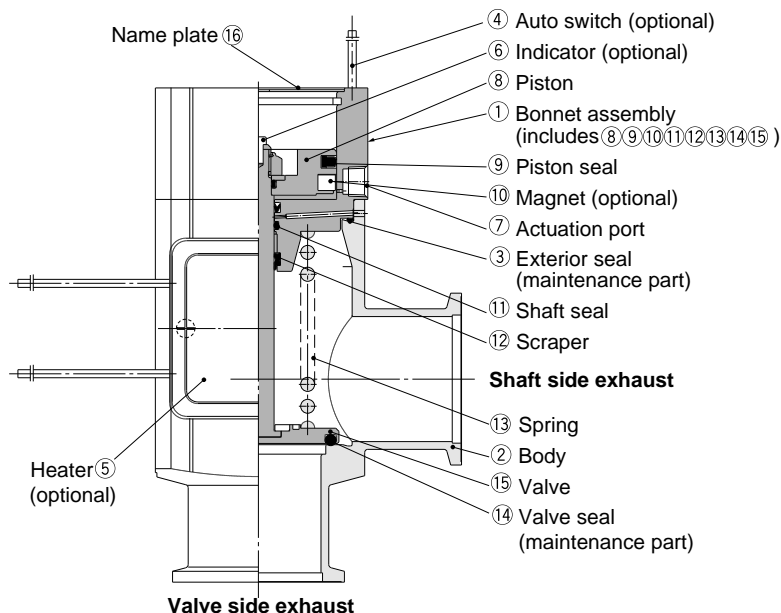

Options

For selections, refer to item 3, model number and option symbol table.

- ④ Auto switch: The magnet (10) actuates the auto switch (4) indicating the position of the integrated valve (15) and piston (8). With 2 auto switches, the open and closed positions are detected, and with 1 auto switch, either the open or closed position is detected. Auto switches are applicable at ordinary temperatures only 5 to 60°C (41 to 140°F).
- ⑤ Heater: Simple heating is performed using thermistors. The valve body can be heated to approximately 80, 100 or 120°C (176, 212, or 248°F), depending on the heater option and the valve size. The type and number of thermistors to be used will vary depending upon size and setting temperature. In the case of high temperature specifications, the bonnet assembly (1) is a heat resistant structure. This is not available with solenoid valve.
- ⑥ Indicator: When the valve is open, an orange marker about 1mm in height appears in the center of the name plate (16).

Dimensions (mm)

1in=25.4mm

XLF/Air operated type

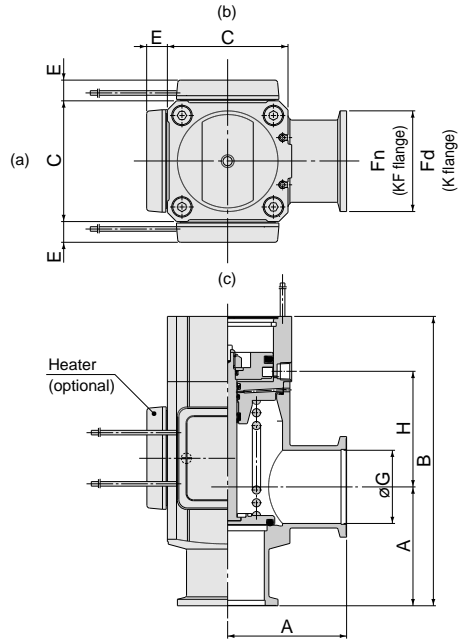

(mm)

Model	A	B	C	D	E Note 1)	Fn	Fd	G	H
XLF-16	40	103	38	1	—	30	—	17	40
XLF-25	50	113	48	1	12	40	—	26	39
XLF-40	65	158	66	2	11	55	—	41	63
XLF-50	70	170	79	2	11	75	—	52	68
XLF-63	88	196	100	3	11	87	95	70	69
XLF-80	90	235	117	3	11	114	110	83	96

Note 1) Dimension E applies when heater option is included. (lead wire length: approx. 1m)

Note 2) (a), (b) and (c) in the above drawing indicate heater mounting positions.

Moreover, heater mounting positions will differ depending on the type of heater.

For further details, refer to mounting positions under Replacement heaters/Part Nos. on page 46.

XLFV/With solenoid valve

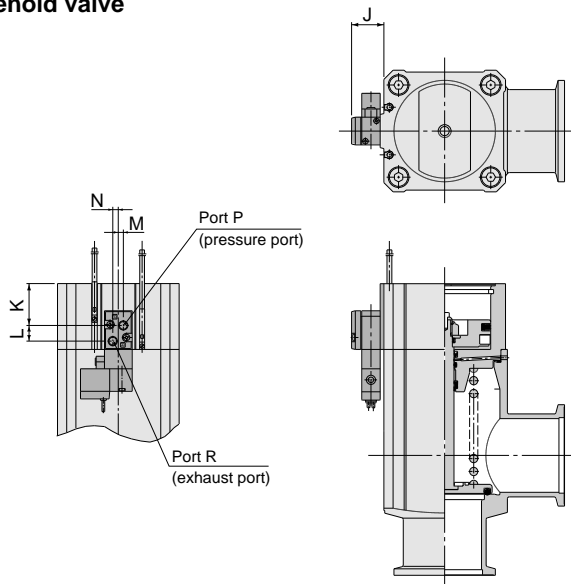

(mm)

Model	J	K	L	M	N
XLFV-16	16.5	13	8.5	3	3
XLFV-25	16.5	14	8.5	3	3
XLFV-40	17.5	23	8.5	3	3
XLFV-50	28	23	12	4	2
XLFV-63	29	29	12	4	2
XLFV-80	29	39	12	4	2

* Other dimensions are the same as XLF.

How to Order

XLG — **16** — **F9N**

High vacuum angle valve

(Double acting, O-ring seal, air operated type)

Flange size

16
25
40
50
63
80

Flange type

Symbol	Type	Applicable flange size
Nil	KF(NW)	16, 25, 40, 50, 63, 80
D	K(DN)	63, 80

Actuation port direction

Nil	Flange side
K	Left flange surface
L	Rear flange surface
M	Right flange surface

Note) Actuation port direction (Example) Left flange surface: Indicates that the direction of the actuation port is to the left side when the flange surface is viewed from the front.

Switch quantity/Mounting position

Symbol	Quantity	Mounting position
Nil	—	—
A	2pcs.	Valve open/closed
B	1pc.	Valve open
C	1pc.	Valve closed

Auto switch type

Nil	Without auto switch (without built-in magnet)
-----	---

Solid state auto switches

F9N	D-F9N
F9P	D-F9P
F9B	D-F9B

Note 1) The standard lead wire length is 0.5m.

For 3m, "L" is added at the end of the part number. (Example) F9NL: D-F9NL

Note 2) An auto switch should be secured against a stopper in the auto switch groove for detection of valve opening, or secured against a stopper or the valve body (depending on the valve size) for detection of valve closing.

Temperature specifications/Heater

Symbol	Temp. range	Heater
Nil	5 to 60°C (41 to 140°F)	None
High temp. type	H0	None
	H1	With heater for 80°C (176°F)
	H2	With heater for 100°C (212°F)
	H3	With heater for 120°C (248°F)

High temperature type combination table

High temperature specifications	Symbol	Model					
		XLG-16	XLG-25	XLG-40	XLG-50	XLG-63	XLG-80
Without heater	H0	●	●	●	●	●	●
With heater for 80° (176°F)	H1	—	●	●	●	●	●
With heater for 100°C (212°F)	H2	—	—	●	●	●	●
With heater for 120°C (248°F)	H3	—	●	●	●	●	●

Note) Auto switches cannot be mounted in the case of high temperature types.



XLG

How to Order

XLGV — **16** — **K** — **F9N** — **1** — **G**

High vacuum angle valve
Double acting, O-ring seal, air operated type with solenoid valve

Flange size

16
25
40
50
63
80

Flange type

Symbol	Type	Applicable flange size
Nil	KF(NW)	16, 25, 40, 50, 63, 80
D	K(DN)	63, 80

Solenoid valve direction

K	Left flange surface
L	Rear flange surface
M	Right flange surface

Note) Solenoid valve direction (Example) Left flange surface: Indicates that the direction of the solenoid valve is to the left side when the flange surface is viewed from the front.

Auto switch type

Nil	Without auto switch (without built-in magnet)
-----	---

Solid state auto switches

F9N	D-F9N
F9P	D-F9P
F9B	D-F9B

Note 1) The standard lead wire length is 0.5m. For 3m, "L" is added at the end of the part number. (Example) F9NL: D-F9NL

Note 2) An auto switch should be secured against a stopper in the auto switch groove for detection of valve opening, or secured against a stopper or the valve body (depending on the valve size) for detection of valve closing.

Light/Surge voltage suppressor

Nil	None
S	With surge voltage suppressor
Z	With light/surge voltage suppressor
U	With light/surge voltage suppressor (non-polar type)

* The S type is not available for AC.
* The U type is DC only.

Electrical entry

G	Grommet (lead wire length 300mm)
H	Grommet (lead wire length 600mm)
L	L type plug connector
M	M type plug connector

Solenoid valve action

Nil	2 position single
W	2 position double

Rated voltage

1	100VAC, 50/60Hz
2	200VAC, 50/60Hz
3	110VAC, 50/60Hz
4	220VAC, 50/60Hz
5	24VDC
6	12VDC

Switch quantity/Mounting position

Symbol	Quantity	Mounting position
Nil	—	—
A	2pcs.	Valve open/closed
B	1pc.	Valve open
C	1pc.	Valve closed



XLGV

Note 1) Option specifications/Combinations

This model has auto switch and K(DN) flange options, but high temperature/heater options are not available.

Note 2) Solenoid valves

2 position single: XLGV-16, 25, 40: SYJ3190 XLGV-50, 63, 80: SYJ5190
2 position double: XLGV-16, 25, 40: SYJ3290 XLGV-50, 63, 80: SYJ5290
Examples) SYJ3190-1GS SYJ3290-1GS

For further details on solenoid valves, refer to the SMC solenoid valve catalog "SYJ 3000, 5000, 7000" (N237).

Note 3) The direction of solenoid valves cannot be changed.

Specifications

Model	XLG(V)-16	XLG(V)-25	XLG(V)-40	XLG(V)-50	XLG(V)-63	XLG(V)-80	
Valve type	Double acting (dual operation), pressurize to open/close						
Fluid	Non-corrosive gas for aluminum alloy (A6063) and SUS304/316						
Operating temperature °C	XLG	5 to 60°C (41 to 140°F) [high temperature type: 5 to 150°C (41 to 302°F)]					
	XLGV	5 to 50°C (41 to 122°F)					
Operating pressure Pa {Torr}	Atmospheric pressure to 1×10^{-6} {760 to 7.5×10^{-9} }						
Conductance d/s <small>Note 1)</small>	5	14	45	80	160	200	
Leakage $\text{Pa m}^3/\text{s}$ {Torr d/s }	Internal	1.3×10^{-10} { 1×10^{-9} } at ordinary temperatures, excluding gas transmission					
	External	1.3×10^{-11} { 1×10^{-10} } at ordinary temperatures, excluding gas transmission					
Operating time ms <small>Note 2)</small>	XLG	40	45	60	60	95	105
	XLGV	45	50	85	90	132	150
Flange type	KF (NW)			KF (NW), K (DN)			
Principle materials	Body: Aluminum alloy Bellows: Stainless steel Seal: FKM (fluoro rubber)						
Surface treatment	Exterior: Hard anodized Interior: Machined for clean environment						
Actuation pressure MPa	0.3 to 0.6 (43 to 87psi)						
Actuation port size	XLG	M5 (10-32 nominal)		Rc(PT) 1/8			
	XLGV	M5 (10-32 nominal) Ports P, R ₁ /R ₂			Rc(PT) 1/8(Port P): M5(10-32 nominal) (Ports R ₁ /R ₂)		
Actuating solenoid valve recommended Cv factor (XLG)	0.06≤	0.09≤	0.11≤	0.15≤	0.4≤	0.5≤	
Service life (Million cycles)	3			2			
Weight kg (lb)	XLG	0.28 (0.62)	0.46 (1.01)	1.1 (2.43)	1.7 (3.74)	3.1 (6.83)	5.1 (11.24)
	XLGV	0.32 (0.71)	0.5 (1.10)	1.14 (2.51)	1.76 (3.88)	3.16 (6.97)	5.16 (11.38)

Note 1) Conductance is the same as that of an elbow with the same dimensions.

Note 2) The operating time with no solenoid valve (XLG) is the same value as the case of the solenoid valve piped directly to the bonnet, where the actuation pressure is 0.5MPa (72psi). The operating time becomes faster under high pressure.

Note 3) For valve heater specifications, refer to "Common Option Specifications, [1] Heaters" on page 37.

Construction/Operation

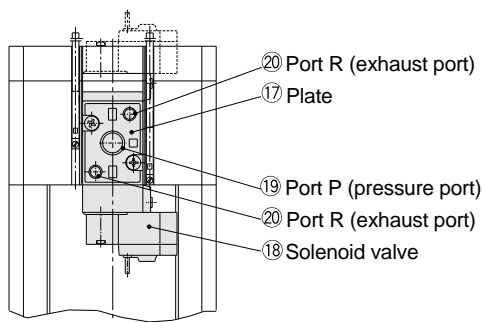

Operating principle

By applying pressure from the actuating port [1]- (7), the piston (8), sealed by the shaft seal (11) and the piston seal (9), is operated opening the valve (actuation port [2]- (7) is released). Conversely, by applying pressure to actuation port [2]- (7), the piston (8), sealed by the cylinder seal (13) and the piston seal (9), is operated closing the valve (15) which is sealed by the valve seal (14) (actuation port [1]- (7) is released). In the case of the XLCV, port P (19) is normally pressurized, and the valve (15) opens when the solenoid valve (18) is turned ON, and closes when it is turned OFF.

Moreover, in the case of a double solenoid, the valve moves to the side where the solenoid valve (18) is turned ON.

Operation is the same as that of the XLC.

For sizes 50, 63 and 80, the valve is sealed with a standard load by means of an overrun mechanism.

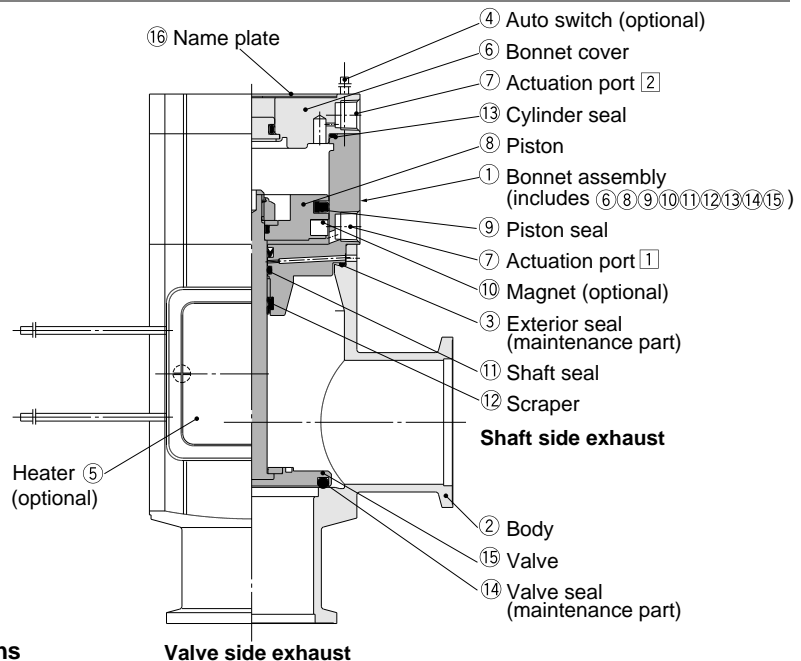

Options

- ④ Auto switch: The magnet (10) actuates the auto switch (4) indicating the position of the integrated valve (15) and piston (8). With 2 auto switches, the open and closed positions are detected, and with 1 auto switch, either the open or closed position is detected. Auto switches are applicable at ordinary temperatures only 5 to 60°C (41 to 140°F).
- ⑤ Heater: Simple heating is performed using thermistors. The valve body can be heated to approximately 80, 100 or 120°C (176, 212, 248°F) depending on the heater option and the valve size. The type and number of thermistors to be used will vary depending upon size and setting temperature. In the case of high temperature specifications, the bonnet assembly (1) is a heat resistant structure. This is not available with solenoid valve.

Dimensions (mm)

1in=25.4mm

XLG/Air operated type

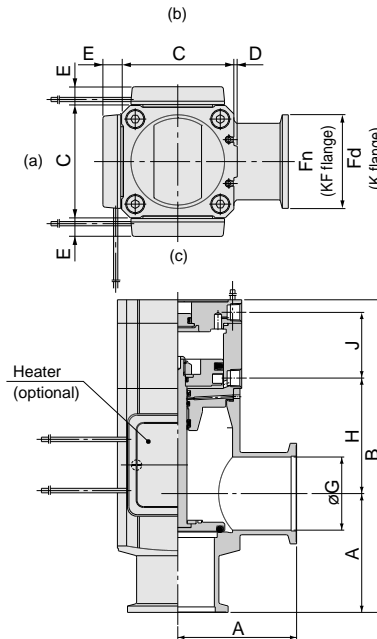

Model	A	B	C	D	E ^{Note 1)}	Fh	Fd	G	H	J
XLG-16	40	110	38	1	—	30	—	17	40	26
XLG-25	50	120	48	1	12	40	—	26	39	28
XLG-40	65	171	66	2	11	55	—	41	63	36
XLG-50	70	183	79	2	11	75	—	52	68	38
XLG-63	88	209	100	3	11	87	95	70	69	45
XLG-80	90	250	117	3	11	114	110	83	96	56

Note 1) Dimension E applies when heater option is included. (lead wire length: approx. 1m)

Note 2) (a), (b) and (c) in the above drawing indicate heater mounting positions.

Moreover, heater mounting positions will differ depending on the type of heater.

For further details, refer to mounting positions under Replacement heaters/Part Nos. on page 46.

XLGV/With solenoid valve

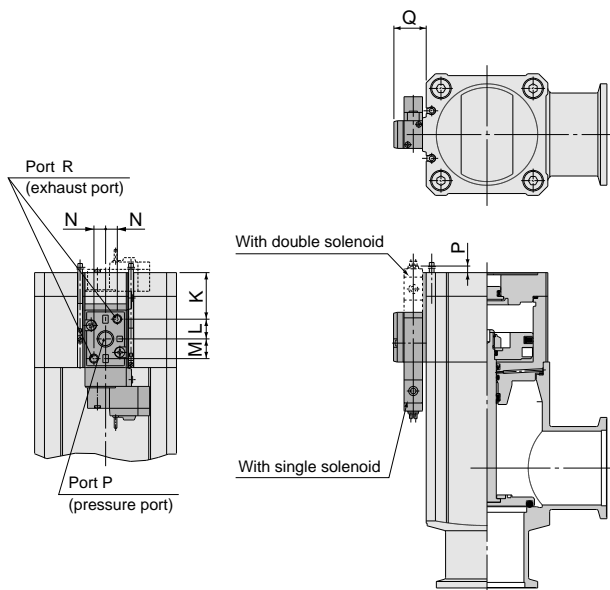

Model	K	L	M	N	P	Q
XLGV-16	14	9	6.5	3	17	16.5
XLGV-25	16	9	6.5	3	15	16.5
XLGV-40	29	9	6.5	3	2	17.5
XLGV-50	26	11	11	6.5	6	28
XLGV-63	32	11	11	6.5	—	29
XLGV-80	45	11	11	6.5	—	29

* Other dimensions are the same as XLG.

How to Order

XLD — **25** — **F9N**

High vacuum angle valve
(Smooth exhaust valve,
normally closed, air operated type)

Flange size

25
40
50
63
80

Flange type

Symbol	Type	Applicable flange size
Nil	KF(NW)	25, 40, 50, 63, 80
D	K(DN)	63, 80

Actuation port direction

Nil	Flange side
K	Left flange surface
L	Rear flange surface
M	Right flange surface

Note) Actuation port direction
(Example) Left flange surface:
Indicates that the direction of the actuation port is to the left side when the flange surface is viewed from the front.

Switch quantity/Mounting position

Symbol	Quantity	Mounting position
Nil	—	—
A	2pcs.	Both sides
B	1pc.	Valve open
C	1pc.	Valve closed

Auto switch type

Nil	Without auto switch (without built-in magnet)
F9N	D-F9N
F9P	D-F9P
F9B	D-F9B

Note 1) The standard lead wire length is 0.5m.
For 3m, "L" is added at the end of the part number.
(Example) F9NL: D-F9NL
Note 2) An auto switch should be secured against a stopper in the auto switch groove for detection of valve opening, or secured against a stopper or the valve body (depending on the valve size) for detection of valve closing.

Temperature specifications/Heater

Symbol	Temp. range	Heater
Nil	5 to 60°C (41 to 140°F)	None
High temp. type	H0	None
	H1	With heater for 80°C (176°F)
	H2	With heater for 100°C (212°F)
	H3	With heater for 120°C (248°F)

High temperature type combination table

High temp. specifications	Symbol	Model				
		XLD-25	XLD-40	XLD-50	XLD-63	XLD-80
Without heater	H0	•	•	•	•	•
With heater for 80°C (176°F)	H1	•	•	•	•	•
With heater for 100°C (212°F)	H2	—	•	•	•	•
With heater for 120°C (248°F)	H3	•	•	•	•	•

Note) Auto switches cannot be mounted in the case of high temperature types.



XLD

How to Order

XLDV — 25 — K — F9N — 1 G

High vacuum angle valve
(Smooth exhaust valve, normally closed, air operated type with solenoid valve)

Flange size

25
40
50
63
80

Flange type

Symbol	Type	Applicable flange size
Nil	KF(NW)	25, 40, 50, 63, 80
D	K(DN)	63, 80

Solenoid valve direction

K	Left flange surface
L	Rear flange surface
M	Right flange surface

Note) Solenoid valve direction (Example) Left flange surface: Indicates that the direction of the solenoid valve is to the left side when the flange surface is viewed from the front.

Auto switch type (for main exhaust valve)

Nil	Without auto switch (without built-in magnet)
-----	---

Solid state auto switches

F9N	D-F9N
F9P	D-F9P
F9B	D-F9B

Light/Surge voltage suppressor

Nil	None
S	With surge voltage suppressor
Z	With light/surge voltage suppressor
U	With light/surge voltage suppressor (non-polar type)

* The S type is not available for AC.
* The U type is DC only.

Electrical entry

G	Grommet (lead wire length 300mm)
H	Grommet (lead wire length 600mm)
L	L type plug connector
M	M type plug connector

Rated voltage

1	100VAC, 50/60Hz
2	200VAC, 50/60Hz
3	110VAC, 50/60Hz
4	220VAC, 50/60Hz
5	24VDC
6	12VDC

Switch quantity/Mounting position

Symbol	Quantity	Mounting position
Nil	—	—
A	2pcs.	Valve open/closed
B	1pc.	Valve open
C	1pc.	Valve closed

Note 1) The standard lead wire length is 0.5m.
For 3m, "L" is added at the end of the part number.
(Example) F9NL: D-F9NL

Note 2) An auto switch should be secured against a stopper in the auto switch groove for detection of valve opening, or secured against a stopper or the valve body (depending on the valve size) for detection of valve closing.

Note 1) Option specifications/Combinations

This model has indicator, auto switch and K(DN) flange options, but high temperature/heater options are not available.

Note 2) Solenoid valves

Model	Initial exhaust valve	Main exhaust valve	Example
XLDV-25		SY114	SY114-1GS
XLDV-40, 50, 63, 80	SY114	SYJ314	SYJ314-1GS

For further details on solenoid valves, refer to the SMC solenoid valve catalogs "SY100" (N219) and "SYJ 300, 500, 700" (N220)



XLDV

Specifications

Model		XLD(V)-25	XLD(V)-40	XLD(V)-50	XLD(V)-63	XLD(V)-80
Valve type		Normally closed (spring return & seal) [both main & initial exhaust valves]				
Fluid		Non-corrosive gas for aluminum alloy (A6063) and SUS304/316				
Operating temperature °C	XLD	5 to 60°C (41 to 140°F) [high temperature type: 5 to 150°C (41 to 302°F)]				
	XLDV	5 to 50°C (41 to 122°F)				
Operating pressure Pa {Torr}		Atmospheric pressure to 1×10^{-6} {760 to 7.5×10^{-9} }				
Conductance l/s ^{Note 1)}	Main exhaust valve	14	45	80	160	200
	Initial exhaust valve	0.5 to 3	2 to 8	2.5 to 11	4 to 18	4 to 18
Leakage $Pa\ m^3/s$ {Torr l/s }	Internal	1.3×10^{-10} { 1×10^{-9} } at ordinary temperatures, excluding gas permeation				
	External	1.3×10^{-11} { 1×10^{-10} } at ordinary temperatures, excluding gas permeation				
Operating time s ^{Note 2)}	Main exhaust valve	0.10	0.21	0.24	0.26	0.28
	Initial exhaust valve	0.07	0.08	0.09	0.23	0.27
Flange type		KF (NW)			KF (NW), K (DN)	
Principle materials		Body: Aluminum alloy Bellows: Stainless steel Seal: FKM (fluoro rubber)				
Surface treatment		Exterior: Hard anodized		Interior: Machined for clean environment		
Actuation pressure MPa		0.4 to 0.7 (58 to 101.50psi) [both main & initial exhaust valves]				
Actuation port size	XLD	M5(10-32 nominal)	Rc(PT) 1/8			
	XLDV	M5(10-32 nominal) Ports P, R				
Actuating solenoid valve recommended Cv factor (XLD)	Main exhaust valve	$0.06 \leq$	$0.09 \leq$	$0.11 \leq$	$0.3 \leq$	$0.35 \leq$
	Initial exhaust valve	$0.01 \leq$	$0.01 \leq$	$0.02 \leq$	$0.02 \leq$	$0.03 \leq$
Service life (Million cycles)		2				
Weight kg (lb)	XLD	0.5 (1.10)	1.2 (2.65)	1.8 (3.97)	3.4 (7.50)	5.6 (12.35)
	XLDV	0.57 (1.26)	1.3 (2.87)	1.9 (4.19)	3.5 (7.72)	5.7 (12.57)

Note 1) The main exhaust valve conductance is the value for the molecular flow of an elbow having the same dimensions. The initial exhaust valve conductance is the value for the viscous flow.

Note 2) The time required for 90% valve movement when an actuation pressure of 0.5MPa (72psi) is applied. There is a difference of about 20% in this value at the upper and lower pressure limits.

Note 3) For valve heater specifications, refer to "Common Option Specifications, [1]Heaters" on page 37.

Construction/Operation

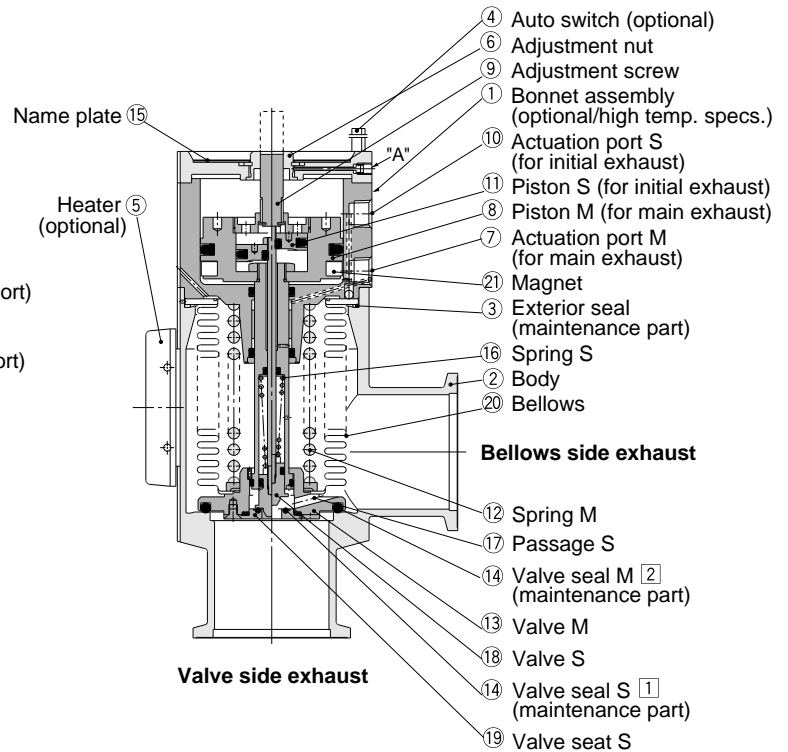
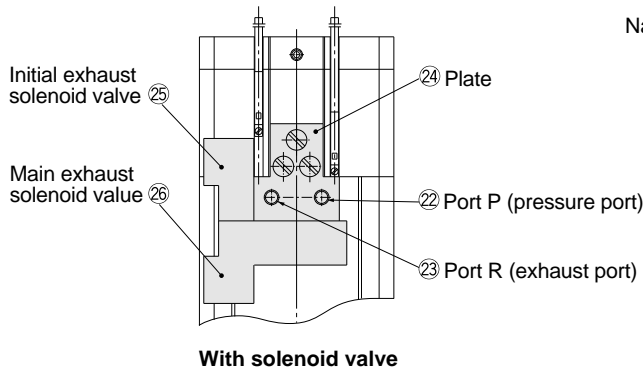

Operating principle

1 Initial exhaust valve opening adjustment

The initial exhaust rate should be adjusted before operation. With actuation port S (10) in an unpressurized state on model XLD, or with initial exhaust solenoid valve (25) in the OFF state on model XLDV, the initial exhaust rate is set to zero by gently turning the adjustment nut (6) to the right until it stops. After confirming the position of the angle adjustment scale on the name plate (15) and the angle adjustment mark on the adjustment nut (6), the initial exhaust rate is adjusted by turning the nut to the left. The pitch of the adjustment screw (9) is 1mm. The number of turns and initial exhaust conductance should be confirmed referring to the figure on the right.

A space is established between the end of the adjustment screw (9) and the shaft of valve S (18), which regulates the amount of movement of the piston S (11). The initial exhaust conductance is determined by the amount of opening between valve S (18) and the valve seal S [1]- (14). Further turning is prevented by locking after adjustment. When the initial exhaust rate will not be adjusted, or when it will be set at a fixed rate, it can be locked by tightening the Section "A" screw with a torque of approximately 5kgf.cm.

2 Operation of the initial exhaust valve

The left section in the drawing shows the initial exhaust valve in a closed condition.

When pressure is applied to the actuation port S (10) on model XLD, or the initial exhaust solenoid valve (25) is turned ON with port P (22) in a pressurized state on model XLDV, air follows the dotted line passing through the space by the shaft and fills the area below the piston S (11). Piston S (11) is stopped when it strikes the adjustment screw (9). Through the movement of piston S (11), the valve S (18) is removed from the valve S seal assembly [1]- (14), and initial exhaust takes place through the passage S (17).

3 Operation of the main exhaust

When pressure is applied to the actuation port M (7) on model XLD, or the main exhaust solenoid valve (26) is turned ON with port P in a pressurized state on model XLDV, the piston M (8) moves upward opening valve M (13). Port S (10) remains pressurized and valve S (18) remains open.

4 Closing of both valves

By removing pressure from actuation port S (10) and actuation port M (7) on model XLD, or turning OFF initial exhaust solenoid valve (25) and main exhaust solenoid valve (26) on model XLDV, the force of spring S (16) and spring M (12) cause valve S (18) and valve M (13) to contact their respective valve seats and seals, thereby sealing them.

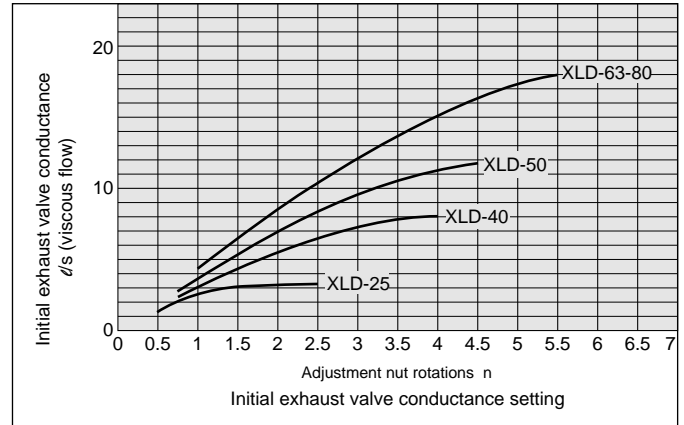

Options

4 Auto switch: The magnet (21) actuates the auto switch (4) indicating the position of the integrated valve M (13) and the piston M (8). With two auto switches, the open and closed positions are detected, and with one auto switch, either the open or closed position is detected. Auto switches are applicable at ordinary temperatures only 5 to 60°C (41 to 140°F).

5 Heater: Simple heating is performed using thermistors. The valve body can be heated to approximately 80, 100 or 120°C (176, 212, or 248°F), depending on the heater option and valve size. The type and number of thermistors to be used will vary depending upon size and setting temperature. In the case of high temperature specifications, the bonnet assembly (1) is a heat resistant structure. This is not available with solenoid valve.

Dimensions (mm)

1in=25.4mm

XLD/Air operated type

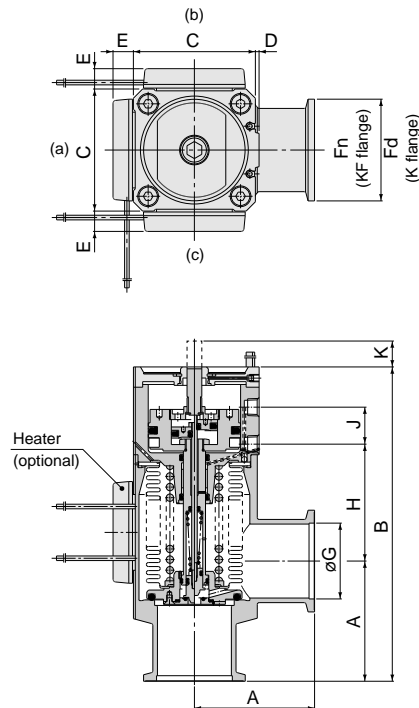

	(mm)										
Model	A	B	C	D	E	Fn	Fd	G	H	J	K
XLD-25	50	123	48	1	12	40	—	26	41	16	6.5
XLD-40	65	170	66	2	11	55	—	41	63	20	14
XLD-50	70	183	79	2	11	75	—	52	68	20	16.5
XLD-63	88	217	100	3	11	87	95	70	72	20	18.5
XLD-80	90	256	117	3	11	114	110	83	98	20	26.5

Note 1) Dimension E applies when heater option is included. (lead wire length: approx. 1m)

Note 2) (a), (b) and (c) in the above drawing indicate heater mounting positions.

Moreover, heater mounting positions will differ depending on the type of heater.

For further details, refer to mounting positions under Replacement heaters/Part Nos. on page 46.

Dimensions (mm)

1 in=25.4mm

XLDV-25/With solenoid valve

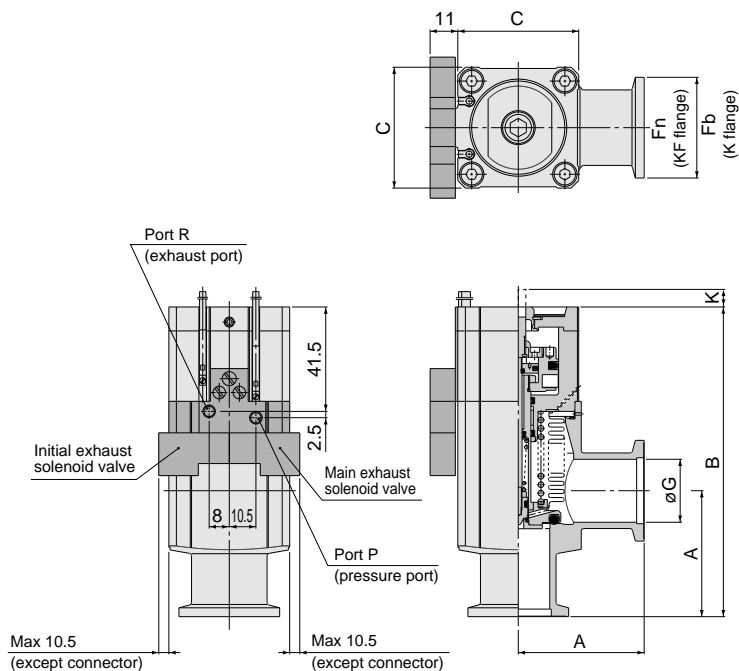

XLDV-40 to 80/With solenoid valve

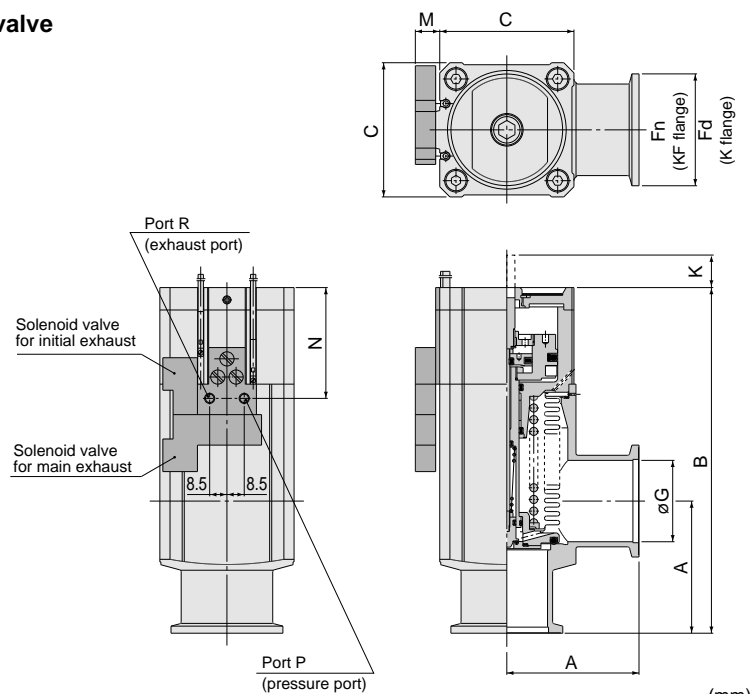

Model	A	B	C	Fn	Fd	G	M	N	K
XLDV-25	50	123	48	40	-	26	-	-	6.5
XLDV-40	65	170	66	55	-	41	12	54.5	14
XLDV-50	70	183	79	75	-	52	12	58.5	16.5
XLDV-63	88	217	100	87	95	70	13	73.2	18.5
XLDV-80	90	256	117	114	110	83	13	83.6	25.5

How to Order

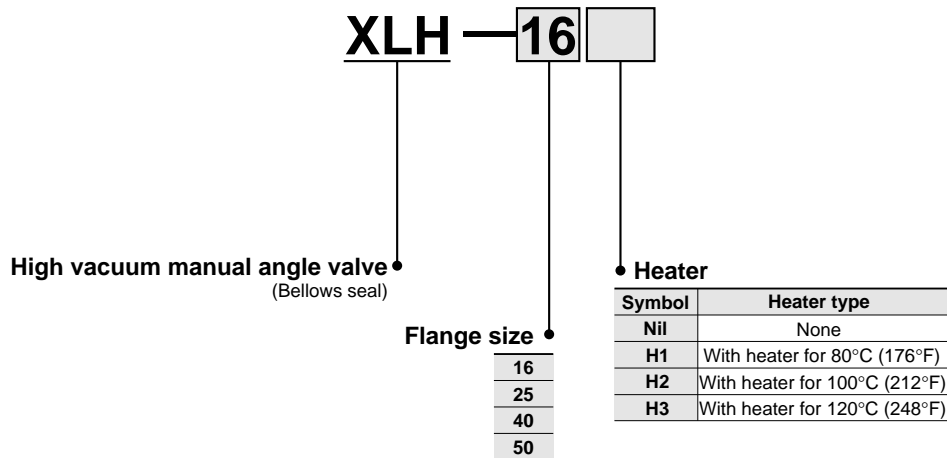

Heater combination table

Setting temperature	Symbol	Model			
		XLH-16	XLH-25	XLH-40	XLH-50
80°C (176°F)	H1	—	•	•	•
100°C (212°F)	H2	—	—	•	•
120°C (248°F)	H3	—	•	•	•

Note) Heater cannot be retrofitted.

Specifications

Model	XLH-16	XLH-25	XLH-40	XLH-50
Fluid	Non-corrosive gas for aluminum alloy (A6063) and SUS304/316			
Operating temperature °C	5 to 150°C (41 to 302°F)			
Operating pressure Pa {Torr}	Atmospheric pressure to 10 ⁻⁶ {760 to 7.5 x 10 ⁻⁹ }			
Conductance <i>l/s</i> <small>Note 1)</small>	5	14	45	80
Leakage Pa m³/s {Torr <i>l/s</i>}	Internal	1.3 x 10 ⁻¹⁰ {1 x 10 ⁻⁹ } at ordinary temperatures, excluding gas transmission		
	External	1.3 x 10 ⁻¹¹ {1 x 10 ⁻¹⁰ } at ordinary temperatures, excluding gas transmission		
Flange type	KF (NW)			
Principle materials	Body: Aluminum alloy Bellows: Stainless steel Seal: FKM (fluoro rubber)			
Surface treatment	Exterior: Hard anodized Interior: Machined for clean environment			
Actuation torque N·m {kgf·cm}	0.1≤{1≤}	0.15≤{1.5≤}	0.35≤{3.5≤}	0.5≤{5≤}
Handle revolutions	5	7	10	13
Service life (Million cycles)	0.1			
Weight kg (lb)	0.23 (0.51)	0.41 (0.90)	1.05 (2.31)	1.62 (3.57)

Note 1) The conductance is the same as that of an elbow of the same dimensions.

Note 2) For valve heater specifications, refer to "Common Option Specifications, [1] Heaters" on page 37.

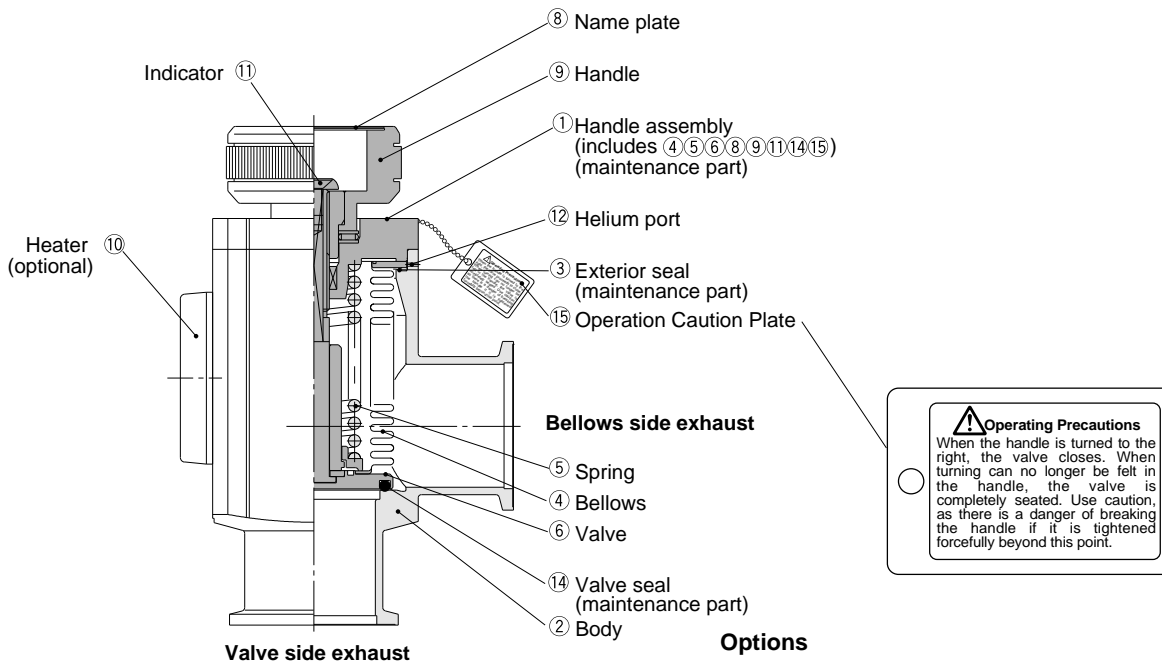

Operating Precautions
When the handle is turned to the right, the valve closes. When turning can no longer be felt in the handle, the valve is completely seated. Use caution, as there is a danger of breaking the handle if it is tightened forcefully beyond this point.

Operating principle

By turning the handle (9) to the left, the valve (6) opens. The handle (9) does not move up and down, but the indicator (11) shows the open or closed position of the valve. As the handle (9) is turned to the right, the valve (6) closes, and when the turning force of the handle (9) suddenly ceases to be felt, the valve (6) is sealed. The sealing force for the valve (6) comes from the spring (5), and is constant.

Options

- ⑩ Heater: Simple heating is performed using thermistors. The valve body can be heated to approximately 80, 100 or 120°C (176, 212 or 248°F), depending on the heater option and the valve size. The type and number of thermistors to be used will vary depending upon size and setting temperature.
- ⑪ Indicator: When the valve is open, an orange marker appears in the center of the name plate (8).

Dimensions (mm)

1in=25.4mm

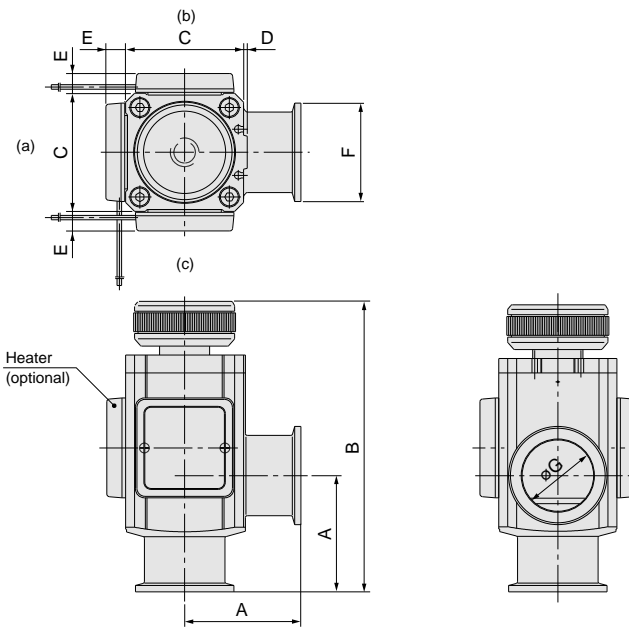

Model	A	B	C	D	E Note 1)	F	G
XLH-16	40	100.5	38	1	—	30	17
XLH-25	50	114	48	1	12	40	26
XLH-40	65	162.5	66	2	11	55	41
XLH-50	70	179.5	79	2	11	75	52

Note 1) Dimension E applies when heater option is included. (lead wire length: approx. 1m)
Note 2) (a), (b) and (c) in the above drawing indicate heater mounting positions.

Moreover, heater mounting positions will differ depending on the type of heater.
For further details, refer to mounting positions under Replacement heaters/Part Nos. on page 46.

How to Order



Starting voltage

5	24VDC
9	Other (48VDC, 100VDC)

Note) Holding voltage is 25% of starting voltage.

Electrical entry

G	Grommet
C	Conduit
T	Terminal
D	DIN terminal

Without control power supply

XLS — **25** — **5** **G**

With control power supply

XLS — **25** — **P** **1** **G**

High vacuum angle valve
 (Bellows pressure balance,
 2 stage voltage switching type)

Valve size

16	KF16
25	KF25

Control power supply

P	With control power
---	--------------------

Electrical entry

G	Grommet
---	---------

Voltage

1	100VAC
2	200VAC
5	24VDC



⚠ Warning

(1) In case there is no control power supply (XLS-25-□□: 24/48/100VDC), starting voltage should be applied for only 0.15 to 0.2s, in accordance with the prescribed method (indicated on the back of the coil). Continuously applying starting voltage can cause overheating of the coil and fire. Holding voltage is 25% of the starting voltage (the application method is shown on the back of the solenoid coil).

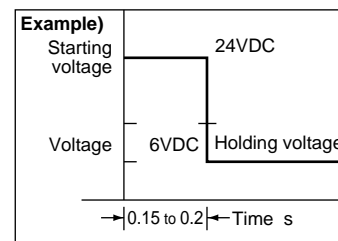

Specifications

Model	XLS-16	XLS-25	XLS-16-P□G	XLS-25-P□G	
Valve type	Normally closed (N.C.)				
Fluid	Non-corrosive gas for aluminum alloy (A6063) and stainless steel (SUS405 equiv.)				
Operating temperature °C	5 to 40°C (41 to 104°F)				
Operating pressure Pa {Torr}	0.2M to 1×10^{-6} { $1.5k$ to 7.5×10^{-9} }				
Conductance l/s	5	8	5	8	
Leakage Pa m ³ /s {Torr l/s}	Internal	1.3×10^{-8} { 1×10^{-7} } at ordinary temperatures, excluding gas permeation			
	External	1.3×10^{-11} { 1×10^{-10} } at ordinary temperatures, excluding gas permeation			
Flange type/size	KF16	KF25	KF16	KF25	
Principle materials	Body : Aluminum alloy Bellows: Stainless steel Seal: FKM (fluoro rubber)				
Surface treatment	Exterior: Hard anodized		Interior Machined for clean environment		
Control power supply	No		Yes		
Operating power supply voltage	24/6, 48/12, 100/24VDC		24VDC 100/200VAC		
Allowable voltage fluctuation %	±10				
Power consumption W	Initial	35	45	35	45
	Holding	6.5	7.5	6.5	7.5
Current consumption A	Initial	1.5	2.0	1.5	2.0
	Holding	0.4	0.5	0.4	0.5
Electrical entry	G, C, D, T type		G type only		
Coil insulation	Class B				
Maximum operating frequency	10 c.p.m				
Service life (Million cycles)	0.5				
Weight kg (lb)	0.4 (0.88)	0.7 (1.54)	0.7 (1.54)	1.0 (2.20)	

Construction/Operation

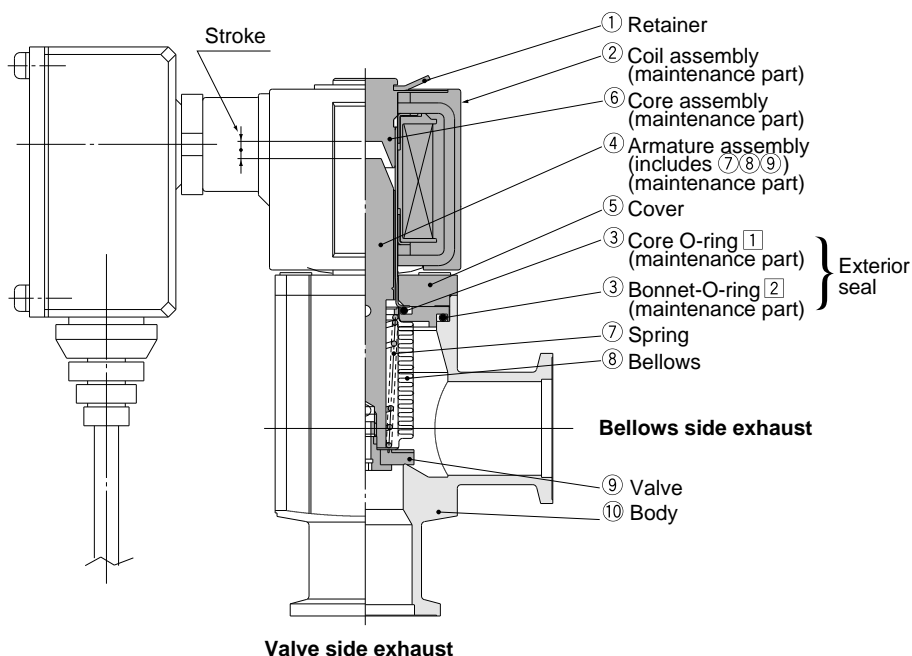

Operating principle

By energizing the coil assembly (2) for 0.15 to 0.2s with the starting voltage, the armature assembly (4) overcomes the reactive force of the spring (7) and is adsorbed to the core assembly (6), opening the valve (9). After that, it is held with 25% of the starting voltage (when there is no power supply). (When there is a power supply, the activating voltage only is applied to the coil assembly (2).) When energizing of the coil assembly (2) is canceled, the armature assembly (4) is separated from the core assembly (6) by the reactive force of the spring (7), closing the valve (9).

Note 1) The fixed seals between the interior of the body (10) and the atmosphere are the exterior seals (3), and the drive section is sealed by the bellows (8).

Note 2) Since the seal diameter of the valve (9) and the effective pressure receiving diameter of the bellows (8) are the same, pressure is in balance and the bellows side can also be used for exhaust.

Series XLS

High Vacuum Angle Valve

Dimensions (mm)

1 in=25.4mm

XLS/Without control power supply
Grommet (G)

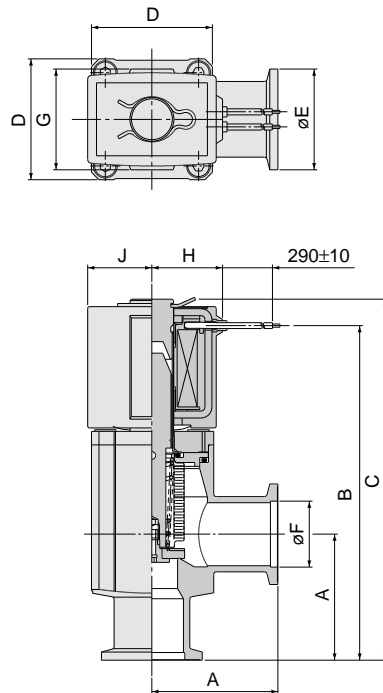

Conduit (C)

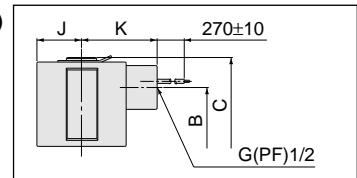

Terminal (T)

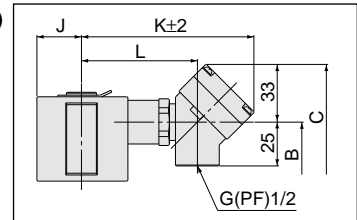

DIN terminal (D)

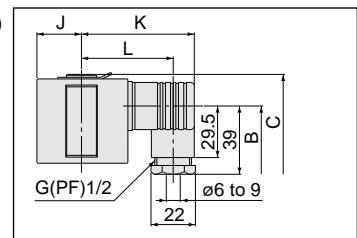

(mm)

Model	A	B	C	D	E	F	G	H	J	K	L
XLS-16-□G	40	104	113	38	30	17.1	35	25.5	23	-	-
XLS-16-□C		96								41	-
XLS-16-□D										60	48
XLS-16-□T										95	62
XLS-25-□G	50	128.5	138.5	48	40	26.2	40	28	25.5	-	-
XLS-25-□C		121.5								43	-
XLS-25-□D		120.5								63	51
XLS-25-□T		121.5								97	66

High Vacuum Angle Valve

Series XLS

Dimensions (mm)

1in=25.4mm

**XLS/With control power supply
Grommet (G)**

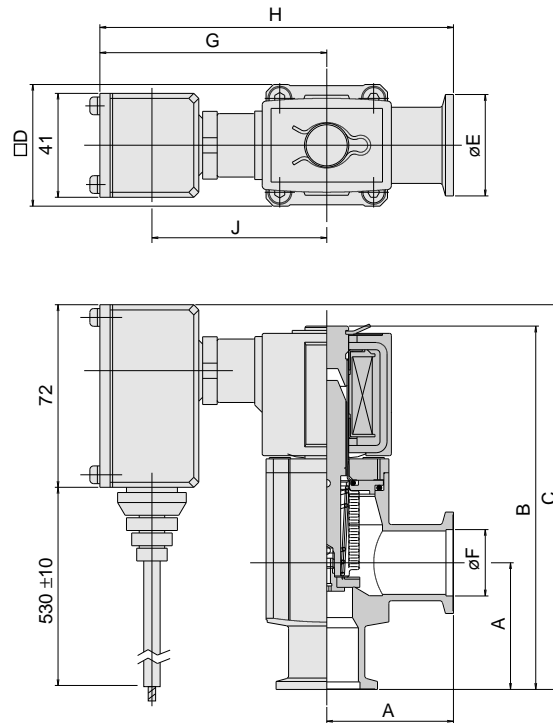

(mm)

Model	A	B	C	D	E	F	G	H	J
XLS-16-P□G	40	113	121	38	30	17.1	87	110	66.5
XLS-25-P□G	50	138.5	147	48	40	26.2	89.5	115	69

How to Order

XSA **1** — **1** **2** **S** — **5** **G** **Spacer** **Electrical options** **Electrical entry** **Voltage**

Normally closed high vacuum straight solenoid valve

Solenoid size

1	No.1
2	No.2
3	No.3

Orifice symbol

1	ø2
2	ø3
3	ø4.5
4	ø6

* Refer to table 1 below for applications.

Fitting size

2	1/4 B
3	3/8 B

* Refer to table 1 below for applications.

Fitting Type

V	VCR®
S	Swagelok®

* VCR® Fitting and Swagelok® Fitting are registered trademarks of the Cajon Company and the Crawford Fitting Company Inc. respectively.

Spacer

Nil	None
A	With spacer

* Refer to Table 3 below in case spacers only are required separately.

Electrical options

Nil	None
S	With surge voltage suppressor
L	With light
Z	With light/Surge voltage suppressor

* Refer to Table 2 below for applications.

Electrical entry

G	Grommet
C	Conduit
T	Terminal
D	DIN terminal

* Refer to Table 2 below for applications.

Voltage

1	100VAC (with rectifier)
5	24VDC
6	12VDC
9	Other (6VDC, 48VDC, 100VDC)

* Refer to Table 2 below for applications.



Table 1: Model, Fitting size, Orifice

Solenoid valve model (fitting size)			Orifice symbol (diameter)			
			1 (ø2)	2 (ø3)	3 (ø4.5)	4 (ø6)
XSA1	XSA2	XSA3	•	•	–	–
2(1/4)	–	–	–	•	•	–
–	2(1/4)	–	–	–	•	–
–	–	2(1/4)	–	–	•	–
–	–	3(3/8)	–	–	–	•

Table 3: Spacer part nos.

Model	Part No.
XSA1	XSA122-8-4
XSA2	XSA232-8-4
XSA3	

Table 2: Voltage, Electrical entry, Electrical options

Electrical entry		G	G	C	D, T		
Electrical options		–	S	–	–	S	L, Z
AC	1(100V)	•	–	–	–	–	–
	5(24V)	•	•	•	•	•	•
DC	6(12V)	•	•	•	•	•	–

Specifications

Model	XSA1-12	XSA1-22	XSA2-22	XSA2-32	XSA3-32	XSA3-43
Action	Normally closed direct acting 2 port solenoid valve					
Fluid	Non corrosive gas for stainless steel (SUS405 equivalent)					
Orifice diameter mmø	2	3		4.5		6
Cv factor	0.17	0.33		0.6		1.05
Actuation pressure difference MPa ^{Note 1)}	0.8	0.3	1.0	0.3	0.8	0.3
Reverse pressure potential MPa ^{Note 2)}	0.5	0.25	0.4	0.2	0.2	0.15
Port A pressure Pa	1×10^{-6}					
Leakage Pa m ³ /s {Torr l/s}	Internal		1.3×10^{-9} { 1×10^{-8} } at ordinary temperatures, excluding gas permeation			
	External		1.3×10^{-11} { 1×10^{-10} } at ordinary temperatures, excluding gas permeation			
	Fitting	VCR®	1.3×10^{-11} { 1×10^{-10} }			
Swagelok®		1.3×10^{-10} { 1×10^{-9} }				
Piping connection system	VCR®/SWJ (Swagelok®)					
Connection size	1/4B					3/8B
Operating temperature °C	5 to 40°C (41 to 104°F)					
Rated voltage	100VAC (with full wave rectifier)			6/12/24/48/100VDC		
Power consumption W	5		8		11	
Allowable voltage fluctuation %	±10					
Weight kg (lb)	0.3 (0.66)		0.5 (1.10)		0.6 (1.32)	
Service life (Million cycles)	2					

Note 1) The actuation pressure difference indicates the difference between Port P (high pressure side) and Port A (low pressure side).

Example) In the case of 0.3MPa, Port A is a vacuum (1Torr or less), while Port P can be pressurized to 0.2MPa (29psi).

Note 2) Reverse pressure potential indicates the pressure which can be applied from Port A when Port P is at atmospheric pressure.

Note 3) Indicates case of grommet type electrical entry.

Construction/Operation

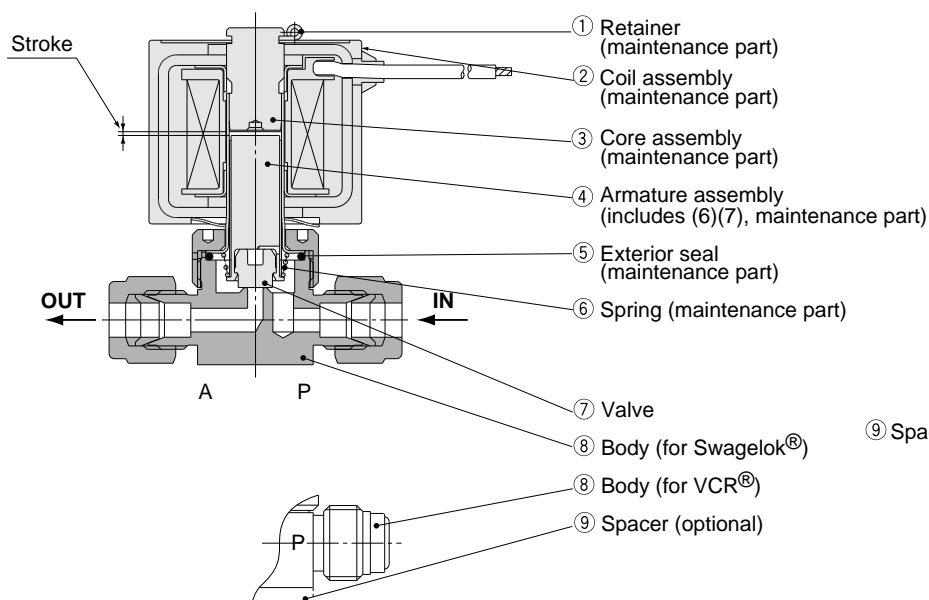

Operating principle

By energizing the coil assembly (2), the armature assembly (4) overcomes the composite force, consisting of the force acting on the valve (7) due to differential pressure and the reactive force of the spring (6), and is adsorbed to the core assembly (3), opening the valve (7).

When energizing of the coil assembly (2) is canceled, the armature assembly (4) is separated from the core assembly (3) by the reactive force of the spring (6), closing the valve (7).

Options

⑨ Spacer: A spacer used to raise the body when fastening it onto a flat area.

Dimensions (mm)

1in=25.4mm

Electrical entry

Grommet (G)

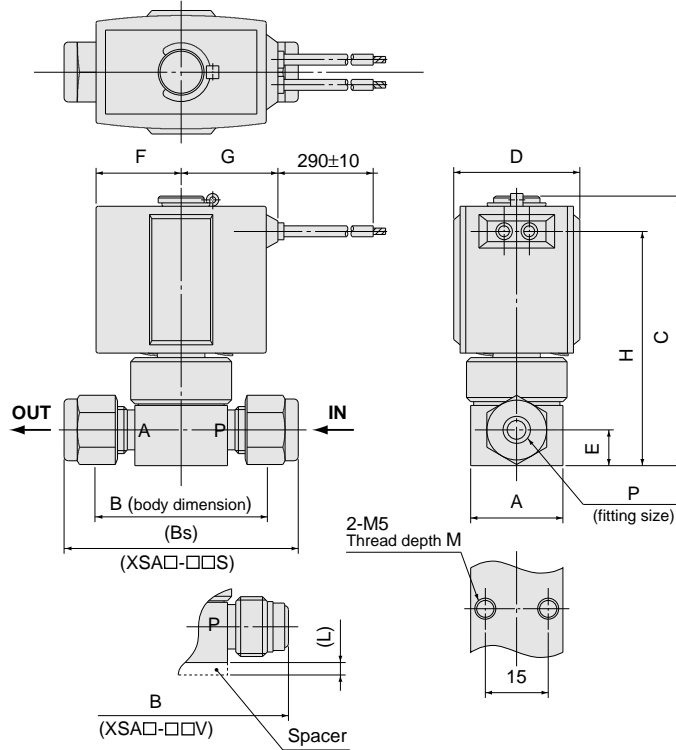

Electrical entry

Conduit (C)

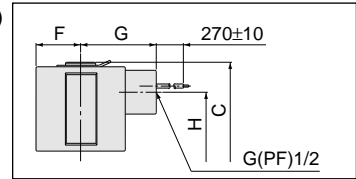

DIN terminal (D)

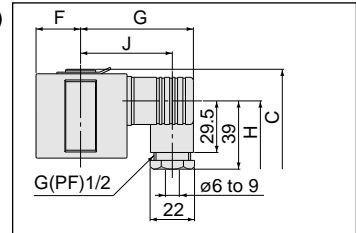

Terminal (T)

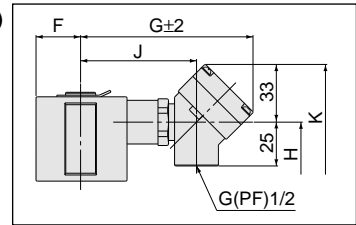

(mm)

Model	A	B		Bs	C	D	E	F	Grommet		Conduit		Terminal		
		() are VCR® type	Swagelok® type						G	H	G	H	G	H	J
XSA1-□2S(V)	22	41(51)	56	64	30	8.5	20	23	56	39	48	92	48	59	81
XSA2-□2S(V)	25	46.5(57)	61	75.5	35	11.5	23	25.5	66	41	58.5	95	58.5	62	91.5
XSA3-32S(V)	25	46.5(57)	61	82	40	11.5	25.5	28	72	43	64	97	64	66	97
XSA3-43S(V)	25	50(66)	65	82	40	11.5	25.5	28	72	43	64	97	64	66	97

Model	DIN terminal			L	M	P (Unit: inch)
	G	H	J			
XSA1-□2S(V)	59	48	47	3	8	1/4
XSA2-□2S(V)	60	58.5	48	5	10	1/4
XSA3-32S(V)	63	64	51	5	10	1/4
XSA3-43S(V)	63	64	51	5	10	3/8

1 With pilot pressure at 0.5MPa (72psi)

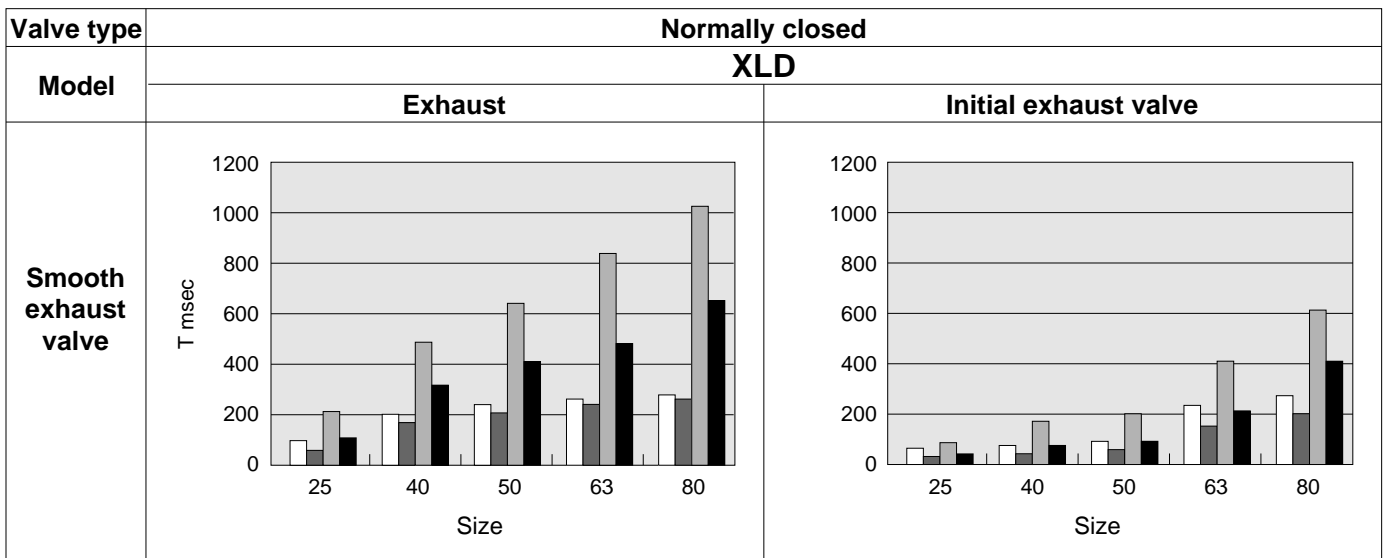
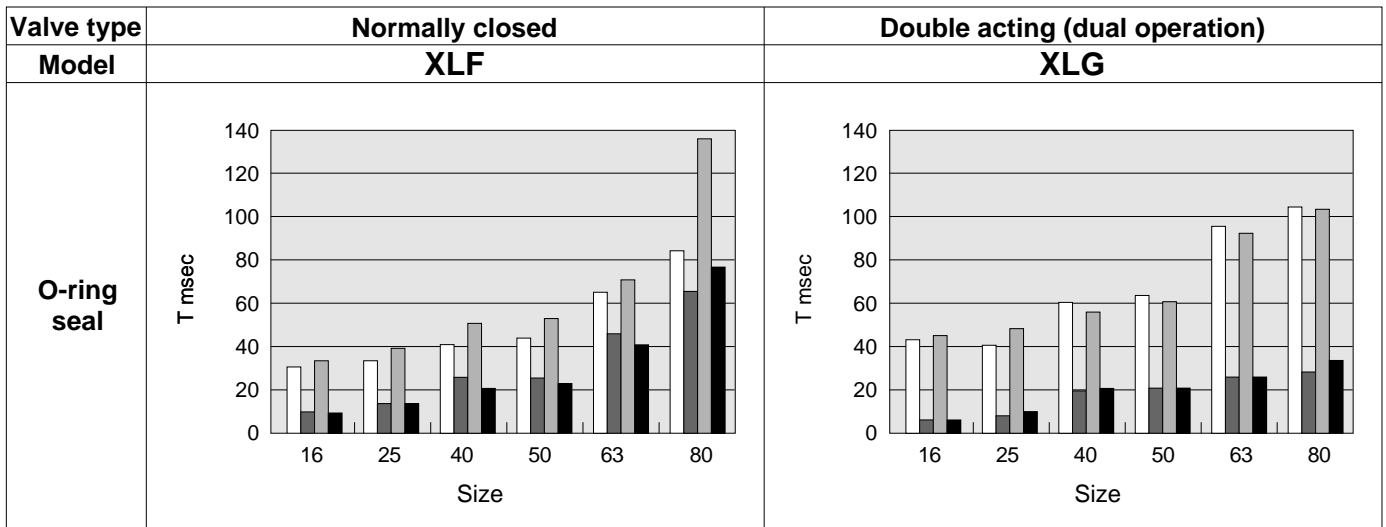
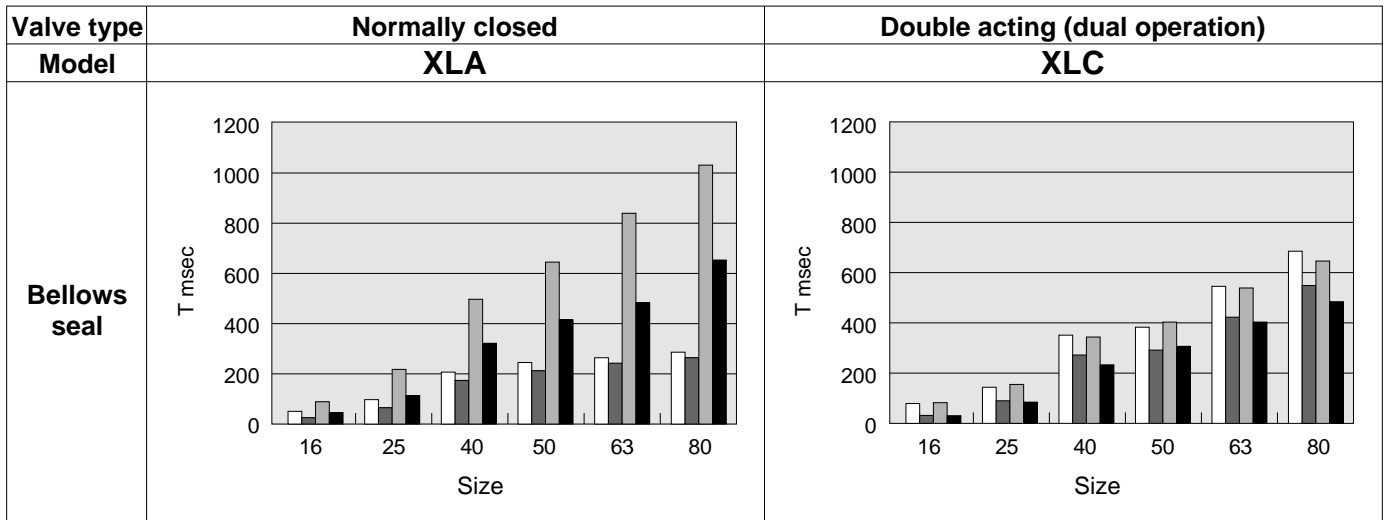

Response time when open (including pneumatic valve)
 Response time when closed (including pneumatic valve)
 Operation time when open (vacuum valve only)
 Operation time when closed (vacuum valve only)

2 As a function of pilot pressure

1MPa = 145 psi

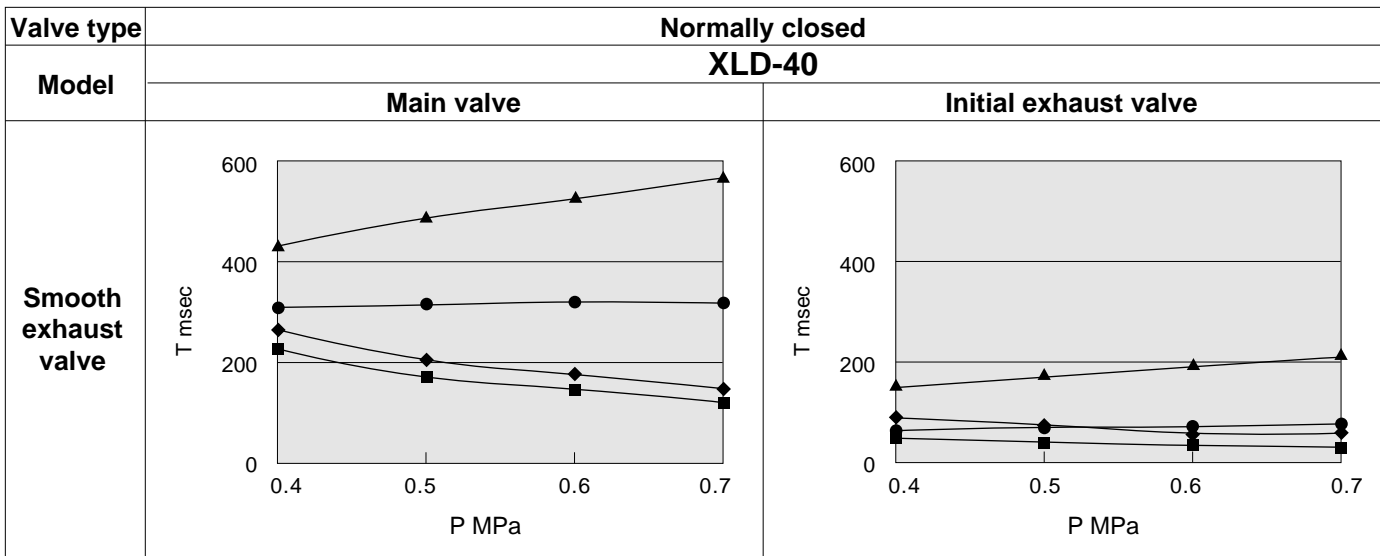
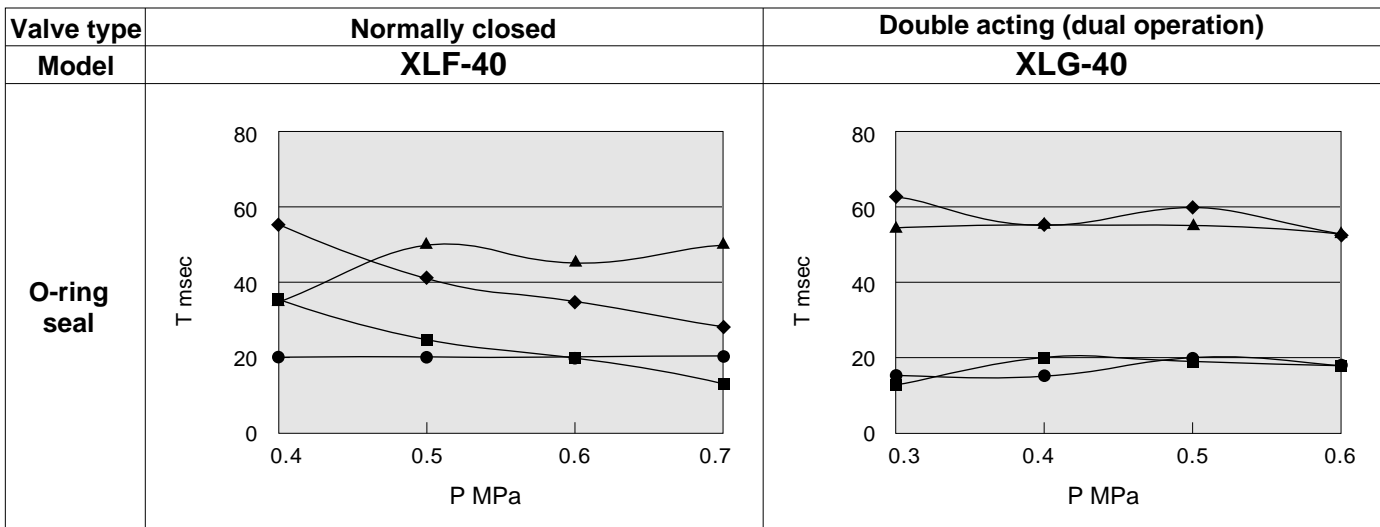
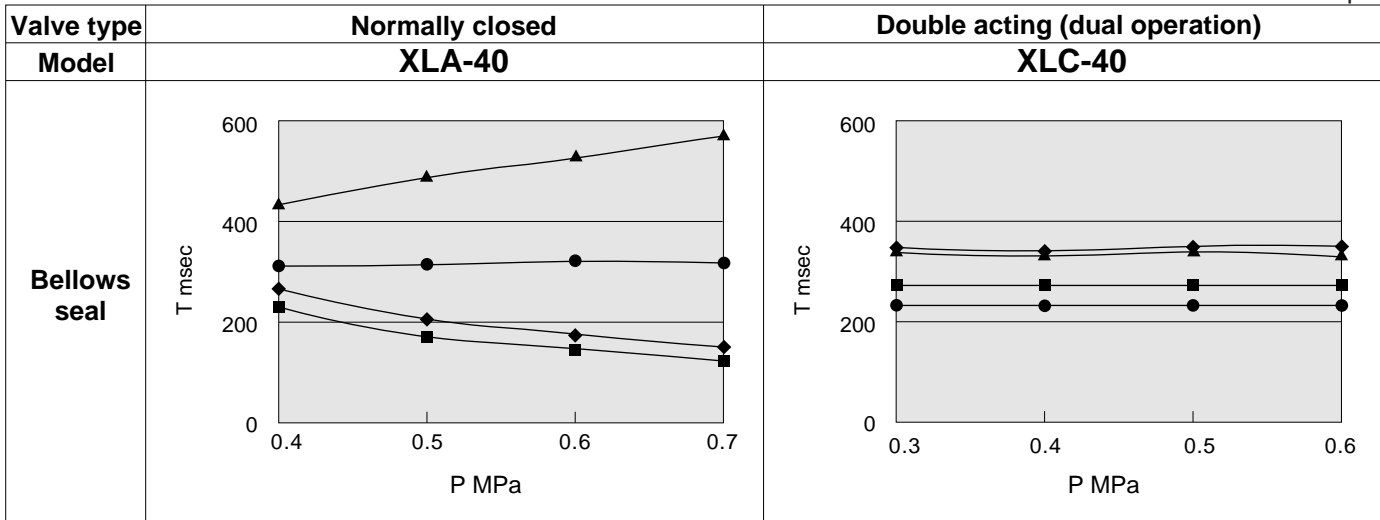

- ◆ Response time when open (including pneumatic valve)
- ▲ Response time when closed (including pneumatic valve)
- Operation time when open (vacuum valve only)
- Operation time when closed (vacuum valve only)

1 Heaters

Valve heaters are common for models XLA, XLC, XLD, XLF, XLG and XLH. Power consumption specifications are shown in the table below.

Item		XL□-25	XL□-40	XL□-50	XL□-63	XL□-80
Rated heater voltage		90 to 125VAC				
Heater power W (nominal value)	H1 80°C (176°F)	200/10	200/20	400/40	400/60	600/100
In-rush/Normal (Option symbol)	H2 100°C (212°F)	–	200/40	200/60	400/100	600/150
	H3 120°C (248°F)	200/30	400/70	400/80	600/130	800/180

Note) In-rush current will flow to the heater for approximately 30 seconds and will then subside.
Refer to Maintenance Parts on page 46 for further details regarding quantity and type.

2 Solid State Auto Switches

Specifications of applicable auto switches are shown below. An auto switch should be secured against a stopper in the auto switch groove for detection of valve opening, or at a position where it lightly touches a stopper or the valve body (depending on the valve size) for detection of valve closing.



Auto Switch Specifications

Auto switch part no.	D-F9N	D-F9P	D-F9B
Electrical entry	Lateral		
Wiring system	3 wire		2 wire
Output system	NPN type	PNP type	–
Applicable load	24VDC relay, PLC		
Power supply voltage	12/24VDC (10 to 28VDC)		–
Current consumption	8mA or less	10mA or less	–
Load voltage	28VDC or less	–	24VDC (10 to 28VDC)
Load current	50mA or less		5 to 30mA
Internal voltage drop	0.4V or less	1.5V or less	4.5V or less
Leakage current	10µA or less at 24VDC		1mA or less at 24VDC
Indicator light	Red LED lights up when ON		

- Operating time 1ms or less
- Lead wires Oil resistant heavy duty vinyl cord, ø2.7, 0.5m
D-F9N, D-F9P 0.15mm² x 3 wires (brown, black, blue [red, white, black])
D-F9B 0.18mm² x 2 wires (brown, blue [red, black])
- Impact resistance 1000m/s²(102G)
- Insulation resistance 50MΩ or more with 500VDC between lead wire and case
- Withstand voltage..... 1000VAC for 1 min. (between lead wire and case)
- Ambient temperature..... -10 to 60°C (14 to 140°F)
- Indicator light Lights up when ON
- Enclosure IEC529 Standard IP67 watertight (JISCO920)

* For a lead wire length of 3m, "L" is added at the end of the part number. Example) D-F9NL

Auto Switch Dimensions (mm)

1in=25.4mm

D-F9N, D-F9P, D-F9B

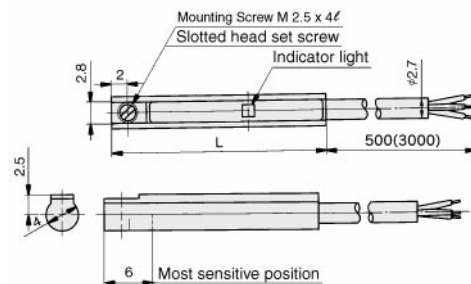

Part No.	L dimension (mm)
D-F9N	22
D-F9P	26.5
D-F9B	26.5

Auto Switch Internal Circuits

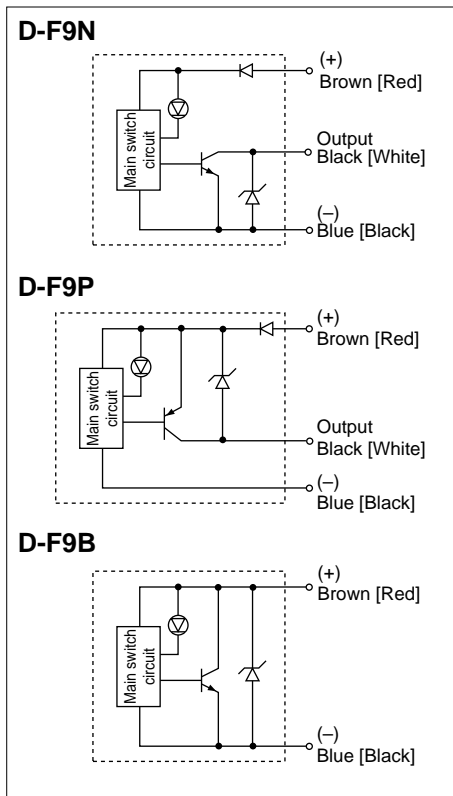

Basic Wiring

Solid state 3 wire, NPN

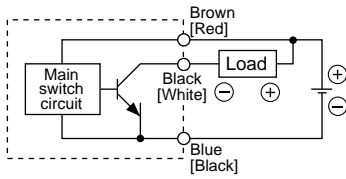

(Power supply for switch and load are separate.)

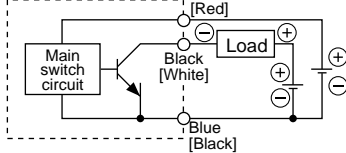

Solid state 3 wire, PNP

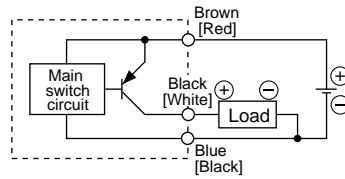

2 wire <Solid state>

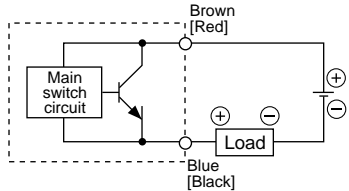
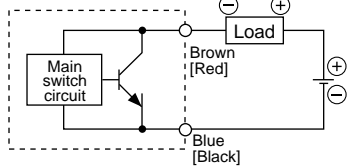

Examples of Connection to PLC or Programmable Logic Controller

Specification for sink input

3 wire, NPN

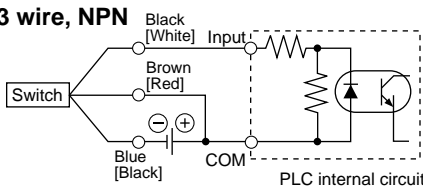

2 wire

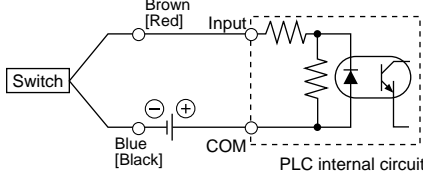

Specification for source input

3 wire, PNP

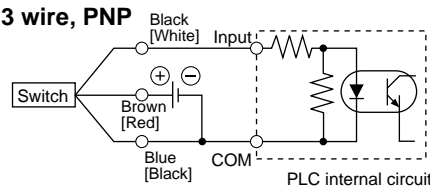

2 wire

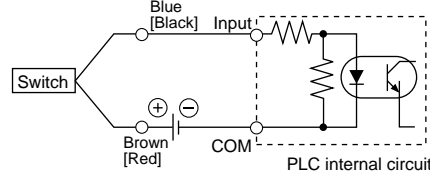

Connect according to the applicable PLC input specifications, as the connection method will vary depending on the PLC input specifications.

Connection Examples for AND (Series) and OR (Parallel)

3 wire

AND connection for NPN output (Using relays)

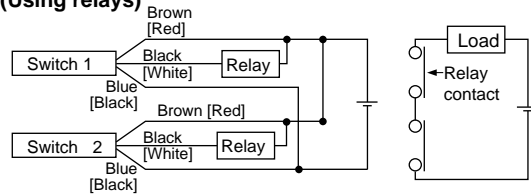

AND connection for NPN output (Performed with switches only)

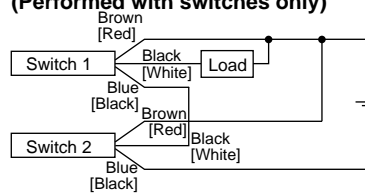

OR connection for NPN output

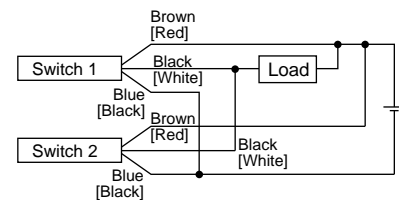

The indicator lights will light up when both switches are turned ON.

2 wire with 2 switch AND connection

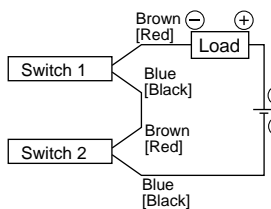

When two switches are connected in series, a load may malfunction because the load voltage will decline when in the ON state. The indicator lights will light up if both of the switches are in the ON state.

2 wire with 2 switch OR connection

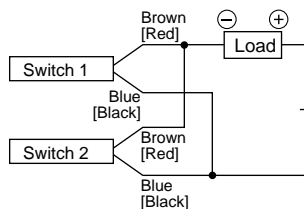

<Solid state>

When two switches are connected in parallel, malfunction may occur because the load voltage will increase when in the OFF state.

<Reed switch>

Because there is no current leakage, the load voltage will not increase when turned OFF, but due to the number of switches in the ON state, the indicator lights will sometimes get dark or not light up, because of dispersion and reduction of the current flowing to the switches.

$$\begin{aligned} \text{Load voltage at ON} &= \text{Power supply voltage} - \text{Residual voltage} \times 2 \text{ pcs.} \\ &= 24\text{V} - 4\text{V} \times 2 \text{ pcs.} \\ &= 16\text{V} \end{aligned}$$

Example: Power supply is 24VDC
Voltage decline in switch is 4V

$$\begin{aligned} \text{Load voltage at OFF} &= \text{leakage current} \times 2 \text{ pcs.} \times \text{load impedance} \\ &= 1\text{mA} \times 2 \text{ pcs.} \times 3\text{k}\Omega \\ &= 6\text{V} \end{aligned}$$

Example: Load impedance is 3kΩ
Leakage current from switch is 1mA

1 Seal Materials Available

FKM (fluoro rubber)

With low outgassing, low permanent-set and low gas permeation rate, this is the most popular seal material for high vacuum. SMC's seal material has undergone a high vacuum degassing process, and at normal temperatures can exhibit performance equivalent to metal seals. For usage in the tens of thousands of hours, a temperature ceiling of 180°C is recommended. When baking under high vacuum, mass numbers 18, 28 and 44 exceed the hydrogen peak, however, after returning to room temperature, these are undetectable, comparable to vacuums with metal sealing. (from SMC data)

Kalrez®

This is an elastomer with the most outstanding resistance to heat and chemicals, but its permanent-set is large, and special caution is required when used in other than static applications. Keeping other conditions the same as in the case of FKM, the recommended temperature ceiling is 250°C. Variations are available with improved plas-

ma (O₂, CF₄) and particulate resistance. Therefore, it is advisable to select types based upon the application.

* Kalrez® is a registered trade mark of DuPont, Inc.

Chemraz®

This material has excellent chemical and plasma resistance and has slightly higher heat resistance than FKM. The recommended operating temperature ceiling is 200°C. Several variations of Chemraz® are available and it is advisable to make a selection based upon the particular plasma being used and other conditions, etc.

* Chemraz® is a registered trade mark of Greene, Tweed & Co.

Silicone

This material is relatively inexpensive, has good plasma resistance and can be used at high temperatures, but its gas permeation rate is large. It is most useful in differentially pumped applications where permeation is not an issue.

2 Shaft Sealing Method

Bellows

SMC valves employ formed-bellows that produce few particulates yet have very long life. Welded-bellows are not used despite their longer life because they generate many more particulates. The cleaning and durability of SMC bellows have been improved through consistent control of surface treatment and handling.

O-ring, etc.

Due to entrainment of gases and generation of particulates, vacuum performance is somewhat inferior to the bellows type. However, high speed operation is possible and durability is comparatively high. The SMC sealing system has an especially long life because, it employs seals that are specially designed to retain the low vapor pressure grease while keeping particulates out.

3 Response time/Operation time

Valve opening

The time from the application of voltage to the actuation solenoid valve until 90% of the valve (XL□) stroke has been completed is the valve opening response time. Valve opening operation time indicates the time from the start of the stroke until 90% of movement has been completed. Both of these become faster as the operating pressure is increased.

Valve closing

The time from the cut off of power to the actuation solenoid valve until 90% of the valve (XL□) return stroke has been completed is the valve closing response time. Valve closing operation time indicates the time from valve opening until 90% of return movement has been completed. Both of these become slower as the operating pressure is increased.

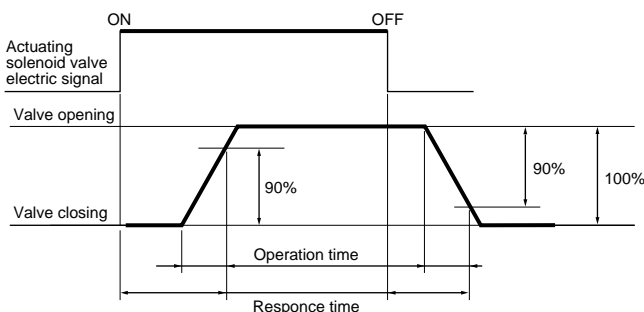

4 Molecular flow conductance

Orifice conductance

In the case of a $\varnothing A$ (cm²) hole in an ultra-thin plate, the conductance "C" results from "V" the average velocity of the gas, "R" the gas constant, "M" the molecular weight and "T" the absolute temperature. From the formula $C=VA/4=(RT/2\pi M)^{0.5}A$, the conductance for 1cm² is $C=11.6A$ l/sec, at an air temperature of 20°C.

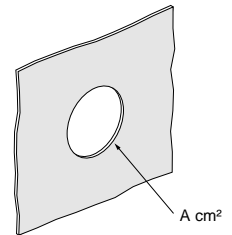

Cylinder conductance

With length "L" (cm) and diameter "D" (cm) where $L \gg D$, from the formula $C=(2\pi RT/M)^{0.5}D^3/6L$, the conductance $C=12.1D^3/L$ l/sec, at an air temperature of 20°C.

Short pipe conductance

From the Clausing's factor "K" and the hole conductance "C" in the drawing below (Clausing's factor drawing), the short pipe conductance C_K is easily found as $C_K=KC$.

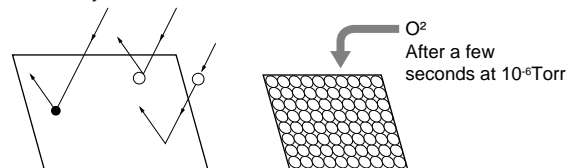

Conductances combined

When each of the separate conductances are given as C₁, C₂ and C_n, the composite conductance ΣC is expressed as:
 $\Sigma C=1/(1/C_1+1/C_2+...1/C_n)$ when in series, and $\Sigma C=C_1+C_2+...C_n$, when in parallel.

5 He leakage

Surface leakage

Leakage that occurs between the deformable seal material and the sealing surface at room temperature (20 to 30°C). This is read within a few minutes after the start of the test.

Gas permeation

This is leakage caused by diffusion through the deformable seal material. As the temperature increases, the diffusion rate increases, and in many cases, becomes greater than surface leakage. The diffusion rate is proportional to the cross-sectional area (cm²) of the seal, and inversely proportional to the seal width (the distance between the vacuum side and the atmosphere). In the case of metal gaskets, only hydrogen diffusion needs to be considered.

6 Outgassing

This is a phenomenon in which gases that are absorbed or adsorbed to chamber surfaces and/or its pores are released into the vacuum. It is lowest on smooth surfaces with a fine oxidize layer. The process of forming the oxidize layer has a particularly large effect. Reductions in outgassing can be achieved by methods such as EL processing to control the oxidation process in the case of aluminum alloys, and anhydrous high temperature oxidation in the case of stainless steel. Processes, such as anodization, can entrap gases in pores causing high outgassing rates. However, after high vacuum baking, the difference in the ultimate pressure with or without anodization is extremely minute.

7 Ultimate pressure

The ultimate pressure P(Torr) is $P=Q/S$, where the sum of the mass flow rates for outgassing (Q_g) and leakage (Q_l) is Q(Torr ℓ/sec) and the exhaust pumping speed is S (ℓ/sec). In cases of very low pressure, the exhaust characteristics of the pump itself may be the limiting factor. In particular, deterioration of pumping speed due to contamination of the pump by atmospheric moisture can be a major factor.

8 Exhaust time (low/medium vacuum)

The time (Δt) required to exhaust a chamber at low vacuum with volume V (ℓ), from pressure P1 to P2, using a pump with pumping speed S (ℓ/sec) is $\Delta t=2.3(V/S)\log(P1/P2)$. In high vacuums, this is subject to the ultimate pressure limit imposed by outgassing and leakage as characterized above.

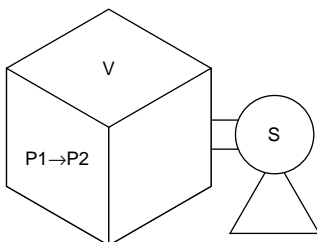

9 Baking

Gases such as oxygen and nitrogen, which have a small adsorption activation energy (E) and a short adsorption residence time (τ), are evacuated quickly. However, in the case of water, which has a high activation energy, evacuation does not progress quickly unless the temperature is raised to shorten residence time. This time may be characterized as $\tau=\tau_0 \exp(E/RT)$ where R is the ideal gas constant and $\tau_0=(\text{approx.})10^{-13}\text{sec}$.

Residence time of water at 20°C is 5.5×10^{-6} sec, whereas at 150°C it is 2.8×10^{-8} sec, or 200 times shorter.

As an example, it took 800 minutes to evacuate moist air from a ø150mm x 500mm SMC test chamber to 10⁻⁹Torr. The same process took only 4 minutes with dry (20ppb) nitrogen.

10 Body materials

Stainless steel has been the traditional material for vacuum systems but the use of aluminum alloys is becoming more common. Stainless steel has good corrosion resistance and strength, but poor thermal conductivity causes large temperature variations, and heavy metal contamination is a problem. Aluminum offers superior temperature uniformity (with 12 times higher thermal conductivity) and in many cases better gas corrosion resistance. Also, it has lower sputter yields from stray energetic particles and contributes no heavy metal contamination. Special anodization and electroless nickel plating are made available by SMC for highly corrosive gases.

11 Flow classification

The relation of the average free path of gas molecules λ and the pipe diameter D expressed as λ/D is the Knudsen number, and the relation of the pressure p(Torr) converted to air at 20°C is expressed as pD. These are the flow classifications shown in the table below.

Classification \ Item	λ/D (Knudsen number)	pD(Torr·cm)
Viscous flow	<0.01	>0.5
Intermediate flow	0.01 to 0.3	0.5 to 0.015
Molecular flow	>0.3	<0.015

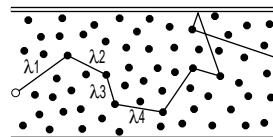

(a) When the pressure is high, there are many collisions among the molecules.

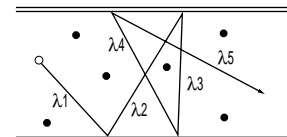

(b) When the pressure is low, collisions are mainly against the walls.

12 Partial pressure

This indicates the residual gas constituents in a vacuum (usually measured with a quadrupole mass spectrometer). At 10⁻⁷ to 10⁻⁹Torr, 90% or more is moisture, at 10⁻¹²Torr or below, 98% or more is hydrogen. The other main residual gases have mass numbers of 28 and 35. (from SMC data)

Technical Data

13 Total pressure

This is the sum of all partial pressures and is equal to $P=nkT$, where the pressure is P, the number of gas molecules is n, Boltzmann's constant is k, and the absolute temperature is T.

14 Average free path

This is the average flight distance (λ cm) that gas molecules travel between collisions with one another. It is inversely proportional to the molecular density (pressure) and may be characterized as $\lambda=0.7/\pi n\delta^2$ or $\lambda=2.33 \times 10^{-20}T/P\delta^2$. Here δ is the molecular diameter (cm), n is the molecular density (units/cm³), T is the absolute temperature (K), and P is the pressure (Torr). In the case of air, for example, this becomes approximately 5cm at room temperature with 10⁻³ Torr. (Refer to the drawing in section [11] Flow classification.)

15 Impingement frequency

The impingement frequency of gas molecules on a unit surface area is $Z=3.53 \times 10^{22}P/(MT)^{1/2}$ collisions/sec cm² where M is the quantity of molecules, T is the absolute temperature (K), and P is the pressure. In the case of oxygen at room temperature and 10⁻⁶Torr, one atomic layer impinges in a few seconds.

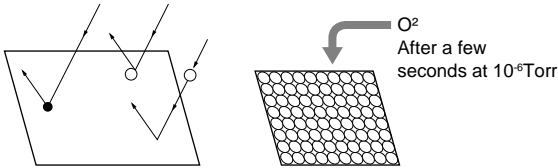

These safety instructions are intended to prevent a hazardous situation and/or equipment damage. These instructions indicate the level of potential hazard by a label of "**Caution**", "**Warning**" or "**Danger**". To ensure safety, be sure to observe these precautions.

 **Caution** : Operator error could result in injury or equipment damage.

 **Warning** : Operator error could result in serious injury or loss of life.

 **Danger** : In extreme conditions, there is a possible result of serious injury or loss of life.

Specific product Precautions 1

**Be sure to confirm the specifications and read the following precautions before handling these valves.
Contact SMC regarding cases which are outside of specifications.**

Air Operated Angle Valves/Series XLA(V), XLC(V), XLD(V), XLF(V), XLG(V)

Precautions on Design

Warning

- **All models**

1. The body material is A6063, the bellows and other parts are SUS316L and SUS304, and the seal material is fluoro rubber (Viton®). Use fluids which are compatible with these materials.
2. Select materials for the actuation pressure piping, and heat resistance for fittings that are suitable for the applicable operating temperatures.

- **Models with auto switch/XLA(V), XLC(V), XLD(V), XLF(V), XLG(V)**

1. The switch section should be kept at a temperature no greater than 60°C.

- **Models with heater/XLA, XLC, XLD, XLF, XLG**

1. When using a model with a heater (thermistor), a device should be installed to prevent over heating.

- **Models with solenoid valve/XLAV, XLCV, XLDV, XLFV, XLGV**

1. For models with a solenoid valve, the temperature of the solenoid valve section should be no greater than 50°C.

Selection

Caution

- **All models**

1. When controlling valve responsiveness, take note of the size and length of piping, as well as the Cv factor (flow rate characteristics) of the actuating solenoid valve. Refer to "Specifications/Recommended Cv factor for actuating solenoid valve" regarding the actuating solenoid valve Cv factor.
2. Actuating pressure should be kept within the specified range. 0.4 to 0.5MPa (4 to 5kgf/cm²) is recommended.
3. Use within the limits of the operating pressure range. Pressure up to 0.2MPa (2kgf/cm²) can be applied momentarily from the bellows side [XLA(V), XLC(V), XLD(V)], or from the shaft side [XLF(V), XLG(V)]. However, the valve side should not be raised above atmospheric pressure, as internal leakage will increase.

- **High temperature types/XLA, XLC, XLD, XLF, XLG**

1. In the case of gases which cause a large amount of deposits, heat the valve body or use a model with heater to prevent deposits in the valve.

Specific Product Precautions 2

Be sure to read before handling.

Mounting

Caution

- **All models**

1. In high humidity environments, keep valves packaged until the time of installation.
2. In cases with switches or solenoid valves, secure the lead wires so that they have sufficient slack, without any unreasonable force applied to them.
3. Perform piping so that excessive force is not applied to the flange sections. In case there is vibration of heavy objects or attachments, etc., secure them so that torque is not applied directly to the flanges.

- **High temperature types (Models/XLA, XLC, XLD, XLF, XLG; Temperature specifications/H0, H1, H2, H3)**

1. In models with heater (thermistor), take care not to damage the insulation components of the lead wires and connector section.
2. The setting temperature for models with heater should be established without a draft or heat insulation. It will change depending on conditions such as heat retaining measures and the heating of other piping. Fine adjustment is not possible.
3. When installing heater accessories or mounting a heater, check insulation resistance at the actual operating temperature. The installation of a short circuit breaker, etc. is recommended.
4. When a valve is to be heated, only the body section should be heated, excluding the bonnet section.
5. When a heater is in operation, the entire valve becomes hot. Be careful not to touch it with bare hands, as burns will result.

Piping

Caution

1. Before mounting, clean the surface of the flange seal and the O-ring with ethanol, etc.
2. Be sure that the flange O-ring is compressed by 15% or more.
3. There is an indentation of 0.1 to 0.2mm in order to protect the flange seal surface, and it should be handled so that the seal surface is not damaged in any way. When using an outer ring, be sure that the O-ring is compressed sufficiently. (There is basically no problem with the outer ring.)

Operating Environment & Vacuum Characteristics

Caution

1. The actuating piston chamber and the bellows chamber [except for XLF(V)/XLG(V)] are directly connected to atmosphere. In cases where it is necessary to avoid the discharge of particulates, use a type (-X12) with piping that conducts both chambers to the outside. When generating a vacuum, do not reduce below 700Torr.
2. The gas permeation through the O-ring (FKM) seal is minute at normal temperatures, but there is a marked increase at high temperatures. Take special precautions against leaks and permeation at high temperatures.
3. O-ring seal types [XLF(V), XLG(V)] suppress the entrainment of gases and the generation of particulates, however, caution should be used as these are not particulate free types, such as the bellows types [XLA(V), XLC(V), XLD(V)].

Maintenance

Caution

1. When removing deposits from a valve, take care not to damage any of its parts.
2. Replace the bonnet assembly when the end of its service life is approached.
3. If damage is suspected prior to the end of the service life, perform early maintenance.
4. When operating at high temperatures, the compression set of the O-ring becomes larger, and a danger of external leakage arises. Confirm that clamps are tightened, etc.
5. SMC specified parts should be used for service. Refer to the Construction/Replacement parts/Service parts table.
6. When removing valve or exterior seals, take care not to damage the sealing surfaces. When installing the valve seal, be sure that the O-ring is not twisted.

Manual Angle Valves/Series XLH

Precautions on Design

Warning

1. The body material is A6063, the bellows and other parts are SUS316 and SUS304, and the seal material is fluoro rubber (Viton®). Use fluids which are compatible with these materials.
2. When using a model with a heater (thermistor), a device should be installed to prevent over heating.

Selection

Caution

1. Use within the limits of the operating pressure range. Pressure up to 0.2MPa (2kgf/cm²) can be applied only momentarily from the bellows side. However, applying pressure from the valve side tends to increase internal leakage.
2. In the case of gases which cause a large amount of deposits, heat the valve body or use a model with heater to prevent deposits in the valve.

Mounting

Caution

1. In models with heater (thermistor), take care not to damage the insulation components of the lead wires and connector section.
2. The setting temperature for models with heater should be established without a draft or heat insulation. It will change depending on conditions such as heat retaining measures and the heating of other piping. Fine adjustment is not possible.
3. When installing heater accessories or mounting a heater, check insulation resistance at the actual operating temperature. A short circuit breaker or fuse should be installed.
4. When a valve is to be heated, only the body section should be heated.
5. In high humidity environments, keep valves packaged until the time of installation.
6. When a heater is in operation, the entire valve becomes hot. Be careful not to touch it with bare hands, as burns will result.
7. Perform piping so that excessive force is not applied to the flange sections. In case there is vibration of heavy objects or attachments, etc., secure them so that torque is not applied directly to the flanges.

Piping

Caution

1. Before mounting, clean the surface of the flange seal and the O-ring with ethanol, etc.
2. Be sure that the flange O-ring is compressed by 15% or more.
3. There is an indentation of 0.1 to 0.2mm in order to protect the flange seal surface, and it should be handled so that the seal surface is not damaged in any way. When using an outer ring, be sure that the O-ring is compressed sufficiently. (There is basically no problem with the outer ring.)

Vacuum Characteristics

Caution

1. The gas permeation of the seal O-ring (FKM) is minute at normal temperatures, but there is a marked increase at high temperatures. Take care regarding gas discharge and gas permeation at high temperatures.

Maintenance

Caution

1. When removing deposits from a valve, take care not to damage any of its parts.
2. Replace the handle assembly when the end of its service life is approached.
3. If damage is suspected prior to the end of the service life, perform early maintenance.
4. When operating at high temperatures, the compression set of the O-ring becomes larger, and a danger of external leakage arises. Confirm that clamps are tightened, etc.
5. SMC specified parts should be used for service. Refer to the Construction/Replacement parts/Service parts table.
6. When removing valve or exterior seals, take care not to damage the sealing surfaces. When installing the valve seal, be sure that the O-ring is not twisted.

Angle Solenoid Valve/Series XLS

Precautions on Design

Warning

1. The body material is A6063, the bellows and other parts are SUS316L and 13Cr stainless steel, and the seal material is fluoro rubber (Viton®). Use fluids which are compatible with these materials.
2. In cases without an operating power supply, the starting voltage is applied for only 0.15 to 0.2s, and after this, a holding voltage (25% of the starting voltage) must be applied. If not performed properly, this can cause burning of the coil and fire, etc.
3. Be certain to install a fuse or short circuit breaker in the power supply circuit.

Selection

Caution

1. Use within the limits of the operating pressure range. There will be a marked decrease in durability at pressures above specification.

Mounting

Caution

1. In high humidity environments, keep valves packaged until the time of installation.
2. Secure the lead wires so that they have sufficient slack, without any unreasonable force applied to them.

Piping

Caution

1. Before mounting, clean the surface of the flange seal and the O-ring with ethanol, etc.
2. Be sure that the flange O-ring is compressed by 15% or more.
3. There is an indentation of 0.1 to 0.2mm in order to protect the flange seal surface, and it should be handled so that the seal surface is not damaged in any way. When using an outer ring, be sure that the O-ring is compressed sufficiently. (There is basically no problem with the outer ring.)

Maintenance

Caution

1. Replace the core and armature assemblies when the end of their service life is approached.
2. If damage is suspected prior to the end of the service life, perform early maintenance.
3. SMC specified parts should be used for service parts. Refer to Replacement parts on page 43 for further details.

Straight Solenoid Valve/Series XSA

Precautions on Design

Warning

1. The body material is SUS304, the electromagnet is 13Cr stainless steel, and the seal material is fluoro rubber (Viton®). Use fluids which are compatible with these materials.
2. Be certain to install a fuse or short circuit breaker in the power supply circuit.

Mounting

Caution

1. In high humidity environments, keep valves packaged until the time of installation.
2. Secure the lead wires so that they have sufficient slack, without any unreasonable force applied to them.

Piping

Caution

1. Before mounting, clean the sealing surface with ethanol, etc.
2. Fasten the VCR® and SWJ (Swagelok)® properly, in accordance with the specified torque and methods prescribed by both companies.
Reference VCR: 1/8 turn after tightening by hand SWJ: 1 1/4 turns after tightening by hand
3. Attach the valve using body bottom mounting screws (2-M5 P=15).
* VCR® Fitting is a registered trade mark of the Cajon Company, and Swagelok ® Fitting is a registered trade mark of the Crawford Fitting Company Inc..

Maintenance

Caution

1. Replace the armature and core assemblies when the end of their service life is approached.
2. If damage is suspected prior to the end of the service life, perform early maintenance.
3. SMC specified parts should be used for service parts.

Maintenance Parts

Air operated angle valve/Manual valve

Bonnet & handle assembly/Construction part number: (1)

Model	Temperature specifications	Valve size					
		XL□□-16	XL□□-25	XL□□-40	XL□□-50	XL□□-63	XL□□-80
XLA	General use	XLA16-30-1	XLA25-30-1	XLA40-30-1	XLA50-30-1	XLA63-30-1	XLA80-30-1
	High temperature	XLA16-30-1H	XLA25-30-1H	XLA40-30-1H	XLA50-30-1H	XLA63-30-1H	XLA80-30-1H
XLAV	General use	XLAV16-30-1	XLAV25-30-1	XLAV40-30-1	XLAV50-30-1	XLAV63-30-1	XLAV80-30-1
XLC	General use	XLC16-30-1	XLC25-30-1	XLC40-30-1	XLC50-30-1	XLC63-30-1	XLC80-30-1
	High temperature	XLC16-30-1H	XLC25-30-1H	XLC40-30-1H	XLC50-30-1H	XLC63-30-1H	XLC80-30-1H
XLCV	General use	XLCV16-30-1	XLCV25-30-1	XLCV40-30-1	XLCV50-30-1	XLCV63-30-1	XLCV80-30-1
XLF	General use	XLF16-30-1	XLF25-30-1	XLF40-30-1	XLF50-30-1	XLF63-30-1	XLF80-30-1
	High temperature	XLF16-30-1H	XLF25-30-1H	XLF40-30-1H	XLF50-30-1H	XLF63-30-1H	XLF80-30-1H
XLFV	General use	XLFV16-30-1	XLFV25-30-1	XLFV40-30-1	XLFV50-30-1	XLFV63-30-1	XLFV80-30-1
XLG	General use	XLG16-30-1	XLG25-30-1	XLG40-30-1	XLG50-30-1	XLG63-30-1	XLG80-30-1
	High temperature	XLG16-30-1H	XLG25-30-1H	XLG40-30-1H	XLG50-30-1H	XLG63-30-1H	XLG80-30-1H
XLGV	General use	XLGV16-30-1	XLGV25-30-1	XLGV40-30-1	XLGV50-30-1	XLGV63-30-1	XLGV80-30-1
XLD	General use	—	XLD25-30-1	XLD40-30-1	XLD50-30-1	XLD63-30-1	XLD80-30-1
	High temperature	—	XLD25-30-1H	XLD40-30-1H	XLD50-30-1H	XLD63-30-1H	XLD80-30-1H
XLDV	General use	—	XLDV25-30-1	XLDV40-30-1	XLDV50-30-1	XLDV63-30-1	XLDV80-30-1
XLH	Standard	XLH16-30-1	XLH25-30-1	XLH40-30-1	XLH50-30-1	—	—

Exterior seal, (M) Valve seal, S Valve seal Assemblies

Construction No.	Description	XL(A, C, H)	XL(F, G)	XLD	XL(A, C, H)	XL(F, G)	XLD	XL□	XLD	XL□	XLD	XL□	XLD	XL□
		[V]-16	[V]-16	[V]-25	[V]-25	[V]-25	[V]-40	[V]-40	[V]-50	[V]-50	[V]-63	[V]-63	[V]-80	[V]-80
③	Exterior seal	AS568-025V	XLF16-6	AS568-030V	XLF25-6	AS568-035V	AS568-039V	AS568-043V	AS568-045V					
⑭ (-2)	(M) Valve seal	B2401-V15V		B2401-V24V		B2401-P42V	AS568-227V	AS568-233V	B2401-V85V					
⑭ (-2)	S Valve seal assembly	—	—	AS568-009V	—	XLD40-2-9-1A	—	XLD50-2-9-1A	—	XLD80-2-9-3A	—	XLD80-2-9-3A	—	—

* Refer to the Construction/Operation drawing of each series for the construction numbers.

Replacement heaters/Part Nos. (XLA, XLC, XLD, XLF, XLG, XLH)

Model	Part Nos./Mounting positions/Set quantity								
	H1 (heater for 80°C)	Mounting position	Set quantity	H2 (heater for 100°C)	Mounting position	Set quantity	H3 (heater for 120°C)	Mounting position	Set quantity
XL□-25	XLA25-60B-1	(a)	1	—	—	—	XLA25-60M-1	(a)	1
XL□-40	XLA25-60B-1	(a)	1	XLA25-60M-1	(a)	1	XLA25-60M-2	(b) (c)	1
XL□-50	XLA25-60B-2	(b) (c)	1	XLA25-60M-1	(a)	1	XLA25-60M-2	(b) (c)	1
XL□-63	XLA25-60B-2	(b) (c)	1	XLA25-60M-2	(b) (c)	1	XLA25-60M-3	(a) (b) (c)	1
XL□-80	XLA25-60B-3	(a) (b) (c)	1	XLA25-60M-3	(a) (b) (c)	1	XLA25-60M-2	(b) (c)	2

Note 1) The above (a), (b), (c) indicate heater mounting positions. The heater mounting positions (a), (b), (c) are shown in the dimension drawing for each series.

Note 2) Heater set quantity indicates multiple heaters.

(Example) The heaters included with XLA-80-H3 are 2 pieces of XLH25-60M-2 (a set including 2 heater units).

Angle solenoid valve

Construction No.	Description	XLS16-□□	XLS16-P□□	XLS25-□□	XLS25-P□□
②	Coil assembly	XLS16-20-□G, C, T, D	XLS16-20-P□G	XLS25-20-□G, C, T, D	XLS25-20-P□G
⑥	Core assembly	XLS16-30-1		XLS25-30-1	
④	Armature assembly	XLS16-30-2		XLS25-30-2	
③-1	Core O-ring	AS568-018V		AS568-018V	
③-2	Bonnet O-ring	AS568-025V		AS568-030V	

Note) The voltage symbol is entered here. (Refer to "How to Order")

The letters G, C, T and D following □ indicate grommet, conduit, terminal and DIN respectively.

* Refer to the Construction/Operation sections for construction numbers.

Be sure to read before handling.

Maintenance Parts

Straight solenoid valve (normally closed)

Construction No.	Description	XSA1	XSA2	XSA3
①	Retainer	VX070-010-1	VX070-011	VX070-012
②	Coil assembly	100VAC	VX021-001GB-X44	VX021-002GB-X44
		DC	(Refer to the section "How to Order Coil Assembly")	
③	Core assembly	XSA122-30-1	XSA232-30-1	XSA343-30-1
④	Armature assembly	XSA122-30-4	XSA232-30-4	XSA343-30-4
⑤	Exterior seal	AS568-016V	AS568-019V	

* Refer to the Construction/Operation sections for construction numbers.

How to Order Coil Assembly (DC for XSA)

VX021 — **001** **C** **B** **05**

Coil assembly

Applications

Size part no.	Applicable Series	
001	No.1 Solenoid	XSA1
002	No.2 Solenoid	XSA2
003	No.3 Solenoid	XSA3

Electrical entry

G	Grommet
C	Conduit
D	DIN terminal

Coil insulation type

B	Class B insulation
---	--------------------

Rated voltage ^{Note1)}

05	24VDC
06	12VDC
51	6VDC
53	48VDC
55	100VDC

Note 1) If the leading "0" is removed from voltage symbols 05, 06, these are the same as the solenoid valve symbols.

Electrical options

Nil	None
S	With Surge voltage suppressor
L	With light
Z	With light/surge voltage suppressor

Terminal box

Nil	None
T	With terminal box

How to Order

(Example) Series XSA1 with 12VDC grommet.

Mode: VX021-001GB-06

(Example) Series XSA2 with 24VDC DIN terminal (terminal box).

Mode: VX021-002DBT-05

(Example) Series XSA3 with 24VDC terminal, surge voltage suppressor and light.

Mode: VX021-003CBTZ-05

Coil combinations

(Electrical entry, Coil insulation type, Electrical options)

Electrical entry	Without electrical options	With electrical options		
		With surge voltage suppressor	With light	With light/surge voltage suppressor
Grommet	GB	GBS	—	—
	CB	—	—	—
Conduit	CBT	CBTS	CBTL	CBTZ
	DB	—	—	—
DIN terminal	DBT	DBTS	DBTL	DBTZ

* The applicable voltage with light, and with light/surge voltage suppressor, is 24VDC only.

World Wide SMC Support...

North American Branch Offices For a branch office near you call: 1-800-SMC-SMC1 (762-7621)

SMC Pneumatics Inc. (Atlanta)
1440 Lakes Parkway, Suite 600
Lawrenceville, GA 30043
Tel: (770) 624-1940
FAX: (770) 624-1943

SMC Pneumatics Inc. (Detroit)
2990 Technology Drive
Rochester Hills, MI 48309
Tel: (248) 299-0202
FAX: (248) 293-3333

SMC Pneumatics Inc. (Rochester)
245 Summit Point Drive
Henrietta, NY 14467
Tel: (716) 321-1300
FAX: (716) 321-1865

SMC Pneumatics Inc. (Austin)
9101 Wall Street, Suite 1030
Austin, TX 78754
Tel: (512) 926-2646
FAX: (512) 926-7055

SMC Pneumatics Inc. (Houston)
9001 Jameel, Suite 180
Houston, TX 77040
Tel: (713) 460-0762
FAX: (713) 460-1510

SMC Pneumatics Inc. (S.F.)
85 Nicholson Lane
San Jose, CA 95134
Tel: (408) 943-9600
FAX: (408) 943-9111

SMC Pneumatics Inc. (Binghamton)
27 Link Drive
Binghamton, NY 13904
Tel: (607) 773-1300
Fax: (607) 773-8008

SMC Pneumatics Inc. (L.A.)
14191 Myford Road
Tustin, CA 92780
Tel: (714) 669-1701
FAX: (714) 669-1715

SMC Pneumatics Inc. (St. Louis)
4130 Rider Trail North
Earth City, MO 63045
Tel: (314) 209-0080
FAX: (314) 209-0085

SMC Pneumatics Inc. (Boston)
Zero Centennial Drive
Peabody, MA 01960
Tel: (978) 326-3600
Fax: (978) 326-3700

SMC Pneumatics Inc. (Milwaukee)
16850 W. Victor Road
New Berlin, WI 53151
Tel: (262) 827-0080
FAX: (262) 827-0092

SMC Pneumatics Inc. (Tampa)
8507-H Benjamin Road
Tampa, FL 33634
Tel: (813) 243-8350
FAX: (813) 243-8621

SMC Pneumatics Inc. (Charlotte)
5029-B West W.T. Harris Blvd.
Charlotte, NC 28269
Tel: (704) 597-9292
FAX: (704) 596-9561

SMC Pneumatics Inc. (Mnpls.)
990 Lone Oak Road, Suite 162
Eagan, MN 55121
Tel: (651) 688-3490
FAX: (651) 688-9013

SMC Pneumatics Inc. (Tulsa)
10203 A East 61st Street
Tulsa, OK 74146
Tel: (918) 252-7820
FAX: (918) 252-9511

SMC Pneumatics Inc. (Chicago)
27725 Diehl Road
Warrenville, IL 60555
Tel: (630) 393-0080
FAX: (630) 393-0084

SMC Pneumatics Inc. (Nashville)
5000 Linbar Drive, Suite 297
Nashville, TN 37211
Tel: (615) 331-0020
FAX: (615) 331-9950

SMC Pneumatics Inc. (Cincinnati)
4598 Olympic Blvd.
Erlanger, KY 41018
Tel: (859) 647-5600
FAX: (859) 647-5609

SMC Pneumatics Inc. (Newark)
3434 US Hwy. 22 West, Ste. 110
Somerville, NJ 08876
Tel: (908) 253-3241
FAX: (908) 253-3452

SMC Pneumatics Inc. (Cleveland)
2305 East Aurora Rd., Unit A-3
Twinsburg, OH 44087
Tel: (330) 963-2727
FAX: (330) 963-2730

SMC Pneumatics Inc. (Phoenix)
2001 W. Melinda Lane
Phoenix, AZ 85027
Tel: (623) 492-0908
FAX: (623) 492-9493

SMC Pneumatics Inc. (Columbus)
3687 Corporate Drive
Columbus, OH 43231
Tel: (614) 895-9765
FAX: (614) 895-9780

SMC Pneumatics Inc. (Portland)
14107 N.E. Airport Way
Portland, OR 97230
Tel: (503) 252-9299
FAX: (503) 252-9253

SMC Pneumatics Inc. (Dallas)
12801 N. Stemmons Frwy, Ste. 815
Dallas, TX 75234
Tel: (972) 406-0082
FAX: (972) 406-9904

SMC Pneumatics Inc. (Richmond)
5377 Glen Alden Drive
Richmond, VA 23231
Tel: (804) 222-2762
FAX: (804) 222-5221

Europe
ENGLAND
SMC Pneumatics (U.K.) Ltd.
GERMANY
SMC Pneumatik GmbH
ITALY
SMC Italia SpA
FRANCE
SMC Pneumatique SA
HOLLAND
SMC Controls BV
SWEDEN
SMC Pneumatics Sweden AB
SWITZERLAND
SMC Pneumatik AG
AUSTRIA
SMC Pneumatik GmbH
SPAIN
SMC España, S.A.
IRELAND
SMC Pneumatics (Ireland) Ltd.

SMC Thailand Ltd.
INDIA
SMC Pneumatics (India) Pvt., Ltd.
North America
CANADA
SMC Pneumatics (Canada) Ltd.
MEXICO
SMC Pneumatics (Mexico) S.A. de C.V.

South America
ARGENTINA
SMC Argentina S.A.
CHILE
SMC Pneumatics (Chile) Ltda.

Oceania
AUSTRALIA
SMC Pneumatics (Australia) Pty. Ltd.
NEW ZEALAND
SMC Pneumatics (N.Z.) Ltd.

Asia
JAPAN
SMC Corporation
KOREA
SMC Pneumatics Korea Co., Ltd.
CHINA
SMC (China) Co., Ltd.
HONG KONG
SMC Pneumatics (Hong Kong) Ltd.
SINGAPORE
SMC Pneumatics (S.E.A.) Pte. Ltd.
PHILIPPINES
SMC Pneumatics (Philippines), Inc.
MALAYSIA
SMC Pneumatics (S.E.A.) Sdn. Bhd.
TAIWAN
SMC Pneumatics (Taiwan) Co., Ltd.
THAILAND

SMC offers the same quality and engineering expertise in many other pneumatic components

Valves	Valves	Cylinders/Actuators	Vacuum	Air Preparation Equipment
Directional Control Valves	Proportional Valves	Compact Cylinders	Vacuum Ejectors	Filters-Regulators-Lubricators
Manual Valves	Mechanical Valves	Miniature Cylinders	Vacuum Accessories	Coalescing Filters
Mufflers	Miniature Valves	Rodless Cylinders	Instrumentation	Micro Mist Separators
Exhaust Cleaners	Fluid Valves	Rotary Actuators	Pneumatic Positioners	Fittings
Quick Exhaust Valves		Pneumatic Grippers	Pneumatic Transducers	Air Fittings

SMC Pneumatics Inc.

P.O. Box 26640, Indianapolis, IN 46226
Tel: (317) 899-4440 • FAX: (317) 899-3102