

3 Port Solenoid Valve

Power Consumption
0.1 W
 With Power Saving Circuit

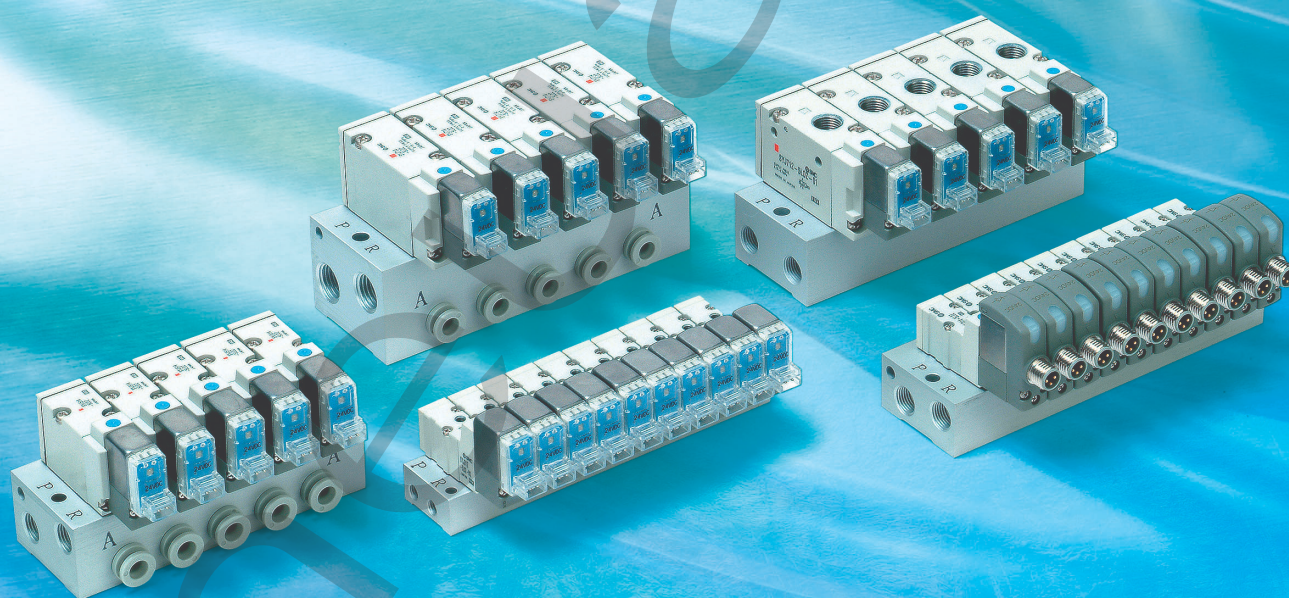

Series **SYJ300/500/700**



Cover (stainless steel)

- **Improved pilot valve**





Pilot valve cover is stronger using stainless steel.
 Mounting thread is also reinforced from size M1.7 to M2.

- **Flow Characteristics**

Series	Flow characteristics		
	C [dm ³ /(s·bar)]	b	Cv
SYJ300	0.36	0.31	0.089
SYJ500	1.2	0.41	0.32
SYJ700	2.7	0.38	0.72

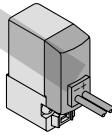
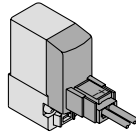
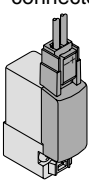
Rubber Seal 3 Port Solenoid Valve Series SYJ300/500/700

Variations

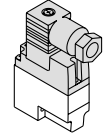
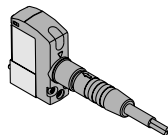
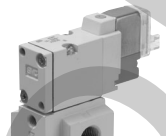
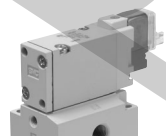
	Series	Port size	Sonic conductance C [dm³/(s·bar)]	Type of actuation	Voltage	Electrical entry	Option	Manual override
							With light/surge voltage suppressor	
Body ported	SYJ300  P.1	M3 x 0.5	Effective area 0.9 mm ² { 2R3 } { (ARR) }	● N.C. ● N.O.	For DC ■ 24 VDC 12 VDC 6 VDC 5 VDC 3 VDC	Grommet  L plug connector  M plug connector 	For DC ■ With surge voltage suppressor ■ With light/surge voltage suppressor	■ Non-locking push type
	SYJ500  P.15	M5 x 0.8	0.66 { 2R3 } { (ARR) }					
	SYJ700  P.33	1/8	2.5 { 2R3 } { (ARR) }					
Base mounted	SYJ300  P.1	M5 x 0.8	0.36 { 2R3 } { (ARR) }	● N.C. ● N.O.	For AC ■ 100 VAC ⁵⁰ / ₆₀ Hz 110 VAC ⁵⁰ / ₆₀ Hz 200 VAC ⁵⁰ / ₆₀ Hz 220 VAC ⁵⁰ / ₆₀ Hz	DIN terminal  (SYJ500, 700 only) M8 connector 	For AC ^{Note)} ■ With light/surge voltage suppressor	■ Push-turn locking slotted type ■ Push-turn locking lever type
	SYJ500  P.15	1/8	1.2 { 2R3 } { (ARR) }					
	SYJ700  P.33	1/8, 1/4	2.7 { 2R3 } { (ARR) }					

 Note) All AC voltage models have built-in surge voltage suppressor.

Manifold Variations

Valve series	A port location	P, R ports size	A port size									
			M3	M5	1/8	With one-touch fitting						
						Applicable tubing O.D.						
			ø4	ø6	ø8	N3	N7	N9				
Body ported	SYJ300	Top	M5 x 0.8	Note 1) ●	—	—	—	—	—	—	—	—
			1/8	Note 2) ●	—	—	—	—	—	—	—	—
	SYJ500	Top	1/8	—	●	—	—	—	—	—	—	—
		SYJ700	Top	1/8	—	—	Note 1) ●	—	—	—	—	—
	1/4		—	—	●	—	—	—	—	—	—	
Base mounted	SYJ300	Side	M5 x 0.8	Note 1) ●	—	—	—	—	—	—	—	—
			1/8	—	●	—	●	—	●	—	—	—
	SYJ500	Bottom	1/8	—	●	●	—	—	—	—	—	—
		Side		—	●	●	●	●	—	●	●	—
	SYJ700	Bottom	1/8	—	—	Note 1) ●	—	—	—	—	—	—
			1/4	—	—	●	—	—	—	—	—	—
Side		1/4	—	—	●	—	●	●	—	●	●	

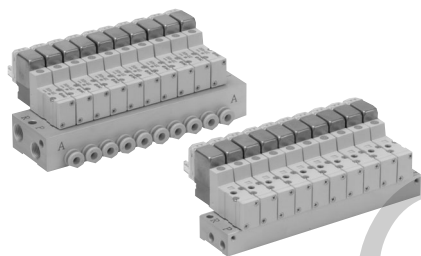

 Note 1) Only for internal pilot
 Note 2) Only for external pilot

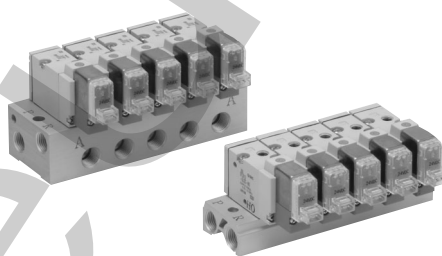

Series SYJ300

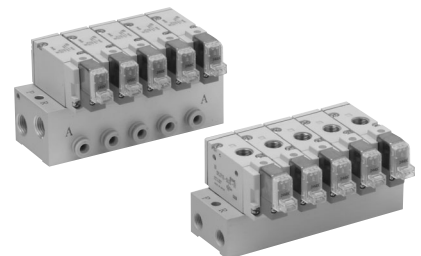

Series SYJ500



Series SYJ700

Rubber Seal 3 Port Pilot Solenoid Valve Series SYJ300

Refer to www.poweraire.com for details of products compatible with overseas standards.

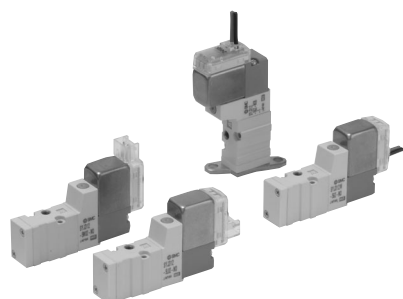

Body ported

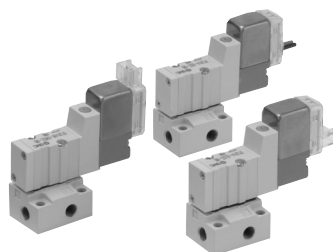

Base mounted

Specifications

Fluid		Air
Operating pressure range MPa	Internal pilot	0.15 to 0.7
Ambient and fluid temperature (°C)		-10 to 50 (No freezing. Refer to page 60.)
Response time ms (at 0.5 MPa) ^{Note 1)}		15 or less
Max. operating frequency (Hz)		10
Manual override (Manual operation)		Non-locking push type, push-turn locking slotted type, push-turn locking lever type
Pilot exhaust method		Individual exhaust for the pilot valve, common exhaust for the pilot and main valve
Lubrication		Not required
Mounting orientation		Unrestricted
Shock/Vibration resistance (m/s²) ^{Note 2)}		150/30
Enclosure		Dust proof (* M8 connector conforms to IP65.)



* Based on IEC529

Note 1) Based on dynamic performance test, JIS B 8374-1981. (Coil temperature: 20°C, at rated voltage, without surge voltage suppressor.)

Note 2) Impact resistance: No malfunction occurred when it is tested with a drop tester in the axial direction and at the right angles to the main valve and armature in both energized and de-energized states every once for each condition. (Value in the initial state)

Vibration resistance: No malfunction occurred in one sweep test between 45 and 2000 Hz. Test was performed to axis and right angle directions of the main valve and armature when pilot signal is ON and OFF. (Value in the initial state)

JIS Symbol

Internal pilot

SYJ31 $\frac{2}{4}$

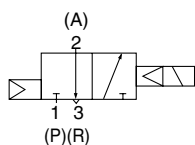

SYJ32 $\frac{2}{4}$

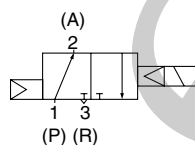

External pilot

SYJ31 $\frac{2}{4}$ R

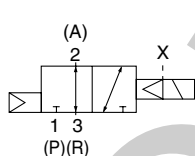

SYJ32 $\frac{2}{4}$ R

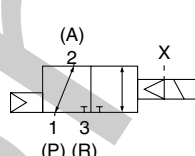

Solenoid Specifications

Electrical entry		Grommet (G), (H), L plug connector (L), M plug connector (M), M8 connector (W)	
Coil rated voltage (V)	DC	24, 12, 6, 5, 3	
	AC 50/60 Hz	100, 110, 200, 220	
Allowable voltage fluctuation		±10% of rated voltage	
Power consumption (W)	DC	Standard 0.35 (With light: 0.4)	
	With power saving circuit	0.1 (With light only)	
Apparent power (VA)	AC	100 V	1.4 (With light: 1.5)
		110 V [115 V]	1.6 (With light: 1.7) [1.7 (With light: 1.8)]
		200 V	2.3 (With light: 2.4)
		220 V [230 V]	2.5 (With light: 2.6) [2.7 (With light: 2.8)]
Surge voltage suppressor		Diode (varistor when non-polar types)	
Indicator light		LED	



* In common between 110 VAC and 115 VAC, and between 220 VAC and 230 VAC.

* For 115 VAC and 230 VAC, the allowable voltage is -15% to +5% of rated voltage.



Made to Order

(For details, refer to pages 57 through 58.)

Flow Characteristics/Weight

Valve model		Type of actuation	Port size	Flow characteristics						Effective area (mm ²)	Weight (g) ^{Note)}		
				1R2 (PRA)			2R3 (ARR)				Grommet	L/M plug connector	M8 connector
				C [dm ³ /(s bar)]	b	Cv	C [dm ³ /(s bar)]	b	Cv				
Body ported	SYJ312	N.C.	M3 x 0.5	—	—	—	—	—	—	0.9	32	33	37
	SYJ322	N.O.		—	—	—	—	—	—				
Base mounted (with sub-plate)	SYJ314	N.C.	M5 x 0.8	0.41	0.18	0.086	0.35	0.33	0.086	—	53 (32)	54 (33)	58 (37)
	SYJ324	N.O.		0.36	0.31	0.089	0.36	0.31	0.089				

 Note) Value for DC. Add 1 g for AC. (): Without sub-plate.

External Pilot



SYJ300R

Pilot valve pressure is supplied separately from the main valve pressure through the use of a separate supply port. It can be used in the vacuum (up to -100 kPa) or low pressure line with 0.15 MPa or less.

Specifications

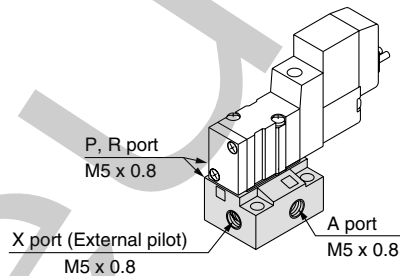
Applicable model	Base mounted (SYJ314R, SYJ324R)	
Operating pressure range MPa	Main pressure	-100 kPa to 0.7
	External pilot pressure	0.15 to 0.7



  Note 1) For manifold base, refer to page 7.
Note 2) External pilot type body ported valves (SYJ3□2R) can only be used on the manifold.

How to Order

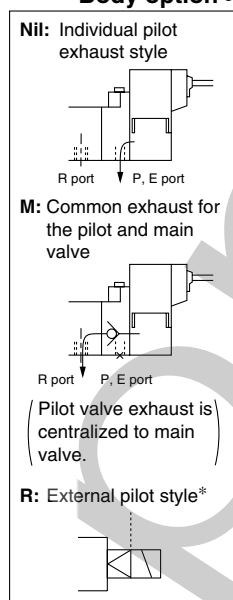
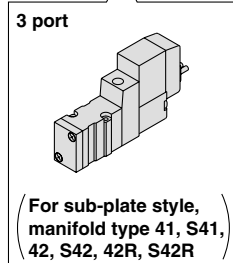
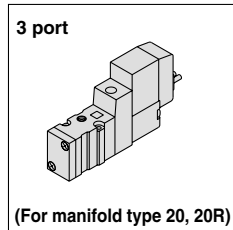

* SYJ3□2R is only for manifold use.

Type of actuation

1	Normally closed
2	Normally open

Rated voltage

DC

5	24 VDC
6	12 VDC
V	6 VDC
S	5 VDC
R	3 VDC

AC (50/60 Hz)

1	100 VAC
2	200 VAC
3	110 VAC [115 VAC]
4	220 VAC [230 VAC]

* For type W□, DC voltage is only available.

Light/surge voltage suppressor

Nil	Without light/surge voltage suppressor
S	With surge voltage suppressor
Z	With light/surge voltage suppressor
R	With surge voltage suppressor (Non-polar type)
U	With light/surge voltage suppressor (Non-polar type)

* For AC voltage valves there is no "S" option. It is already built-in to the rectifier circuit.
* For type R, U, DC voltage is only available.
* Power saving circuit is only available in the "Z" type.

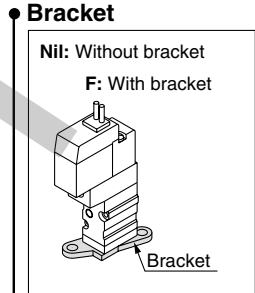

* Bracket is mounted.
* External pilot type is not available.



Coil specifications

Nil	Standard
T	With power saving circuit (24, 12 VDC only)

* Power saving circuit is not available in the case of W□ type.

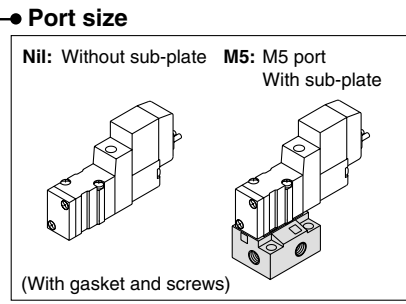

Electrical entry

24, 12, 6, 5, 3 VDC/100, 110, 200, 220 VAC				24, 12, 6, 5, 3 VDC	
Grommet	L plug connector	M plug connector		M8 connector	
G: Lead wire length 300 mm	L: With lead wire (Length 300 mm)	M: With lead wire (Length 300 mm)	MN: Without lead wire	WO: Without connector cable	
H: Lead wire length 600 mm	LN: Without lead wire	LO: Without connector	MO: Without connector		

* LN, MN type: with 2 sockets.
* For connector cable of M8 connector, refer to page 67.

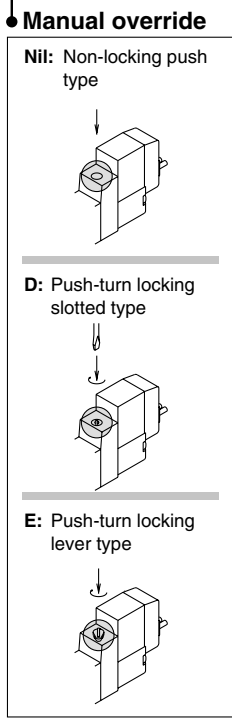

Note) When placing an order for body ported solenoid valve as a single unit, mounting bolt for manifold and gasket are not attached. Order them separately, if necessary. (For details, refer to page 8.)

Construction

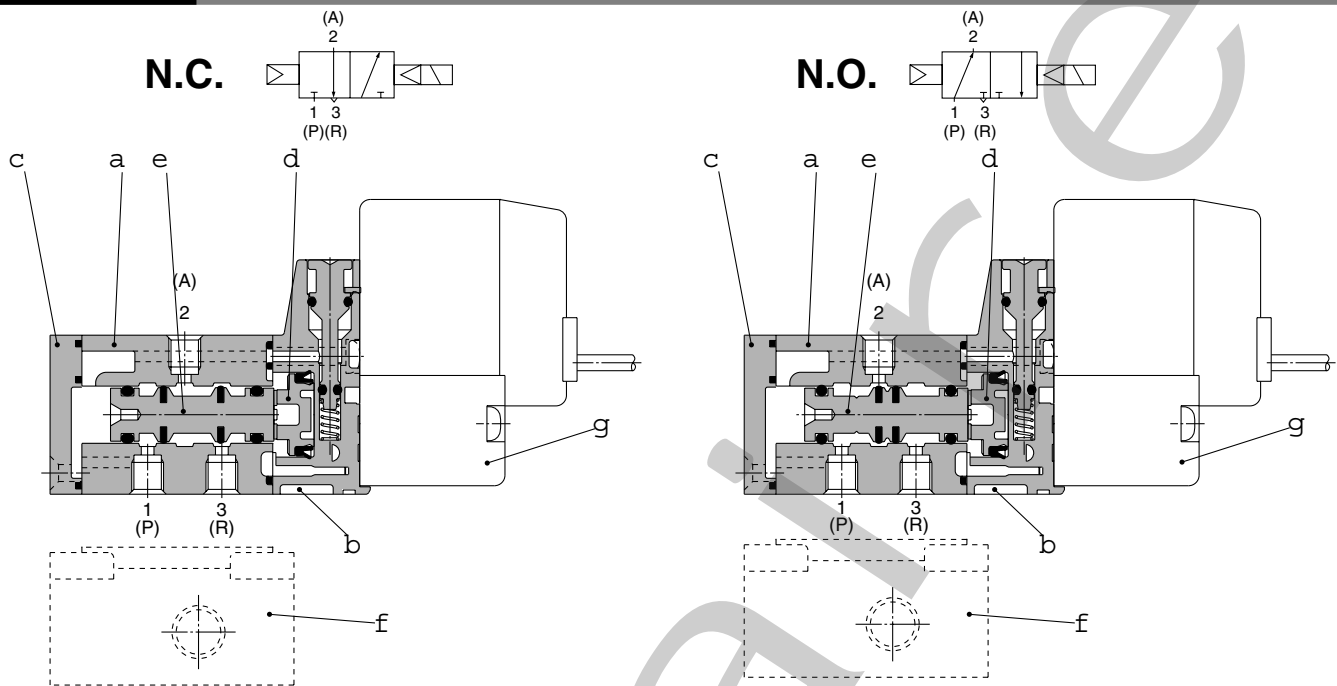

Component parts

No.	Description	Material	Note
1	Body	Zinc die-casted	White
2	Piston plate	Resin	White
3	End cover	Resin	White
4	Piston	Resin	-
5	Spool valve assembly	Aluminum, H-NBR	-

Replacement parts

No.	Description	No.	Note
6	Sub-plate	SYJ300-9-1	Zinc die-casted
7	Pilot valve	V111(T)-□□□□	

How to Order Pilot Valve Assembly

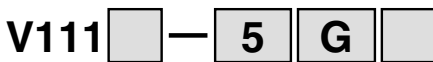

Coil specifications

Nil	Standard: DC specifications
A	Standard: AC specifications
T	With power saving circuit (24, 12 VDC only)

* Power saving circuit is not available in the case of W□ type.

Rated voltage

5	24 VDC
6	12 VDC
V	6 VDC
S	5 VDC
R	3 VDC
1	100 VAC 50/60 Hz
2	200 VAC 50/60 Hz
3	110 VAC 50/60 Hz [115 VAC 50/60 Hz]
4	220 VAC 50/60 Hz [230 VAC 50/60 Hz]

* For type W□, DC voltage is only available.

Electrical entry

G	Grommet, 300 mm lead wire	
H	Grommet, 600 mm lead wire	
L	L plug connector	With lead wire
LN		Without lead wire
LO	Without connector	
M	M plug connector	With lead wire
MN		Without lead wire
MO		Without connector
W0	M8 connector	Without connector cable

* For connector cable of M8 connector, refer to page 67.

Light/surge voltage suppressor

Nil	Without light/surge voltage suppressor
S	With surge voltage suppressor
Z	With light/surge voltage suppressor
R	With surge voltage suppressor (Non-polar type)
U	With light/surge voltage suppressor (Non-polar type)

* For AC voltage valves there is no "S" option. It is already built-in to the rectifier circuit.

* For "R" and "U", DC voltage is only available.

* Power saving circuit is only available in the "Z" type.

How to Order Connector Assembly for L and M Plug Connector

For DC: **SY100-30-4A-** □

For 100 VAC: **SY100-30-1A-** □

For 200 VAC: **SY100-30-2A-** □

For other voltages of AC: **SY100-30-3A-** □

Without lead wire: **SY100-30-A**
(with connector and 2 of sockets only)

Lead wire length

Nil	300 mm
6	600 mm
10	1000 mm
15	1500 mm
20	2000 mm
25	2500 mm
30	3000 mm
50	5000 mm

How to Order M8 Connector Cable

V100-49-1- □

Cable length

1	300 mm
2	500 mm
3	1000 mm
4	2000 mm
7	5000 mm

Series SYJ300

Body Ported

 * [] for AC

Grommet (G), (H): SYJ3□2-□^G□□-M3

With bracket:
SYJ3□2-□^G□□-M3-F

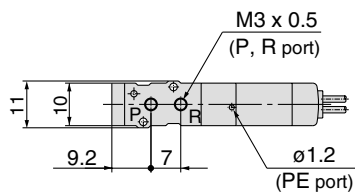
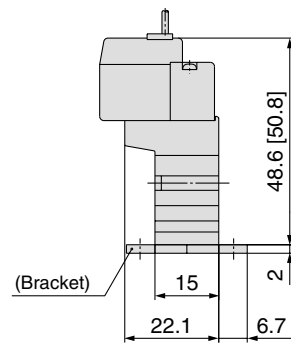
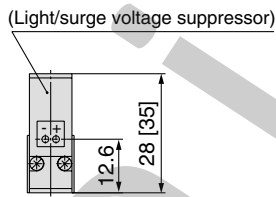
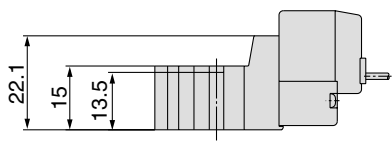
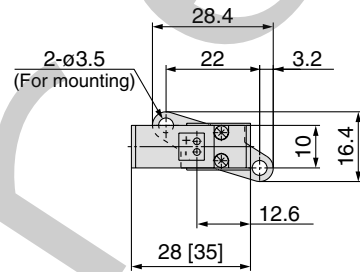
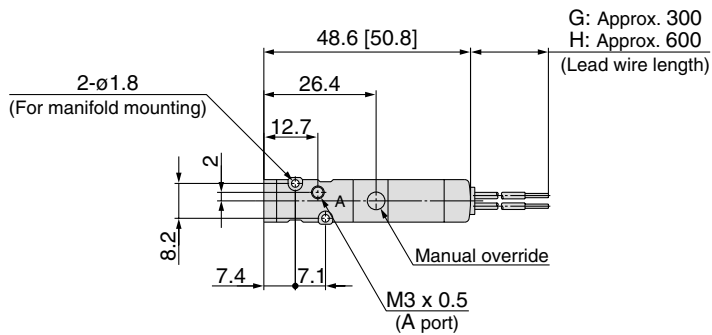

L plug connector (L):
SYJ3□2-□L□□-M3

M plug connector (M):
SYJ3□2-□M□□-M3

M8 connector (W0):
SYJ3□2-□W0□□-M3

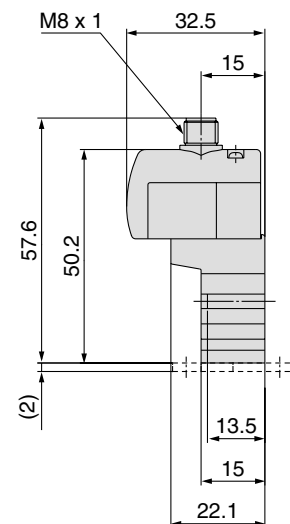
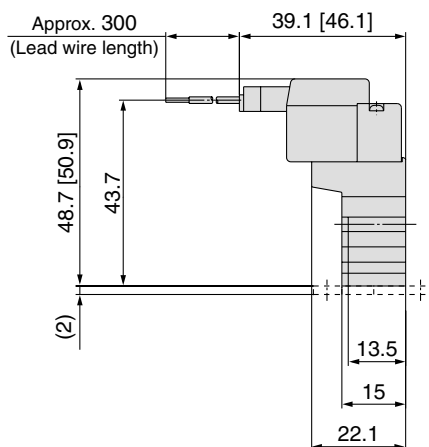
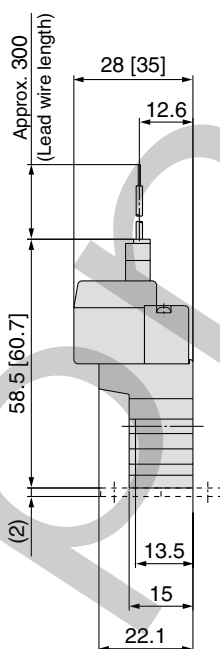

 * Refer to the page 68 for dimensions with connector cable.

Base Mounted (With Sub-plate)



Grommet (G), (H): SYJ3□4-□^G□□-M5

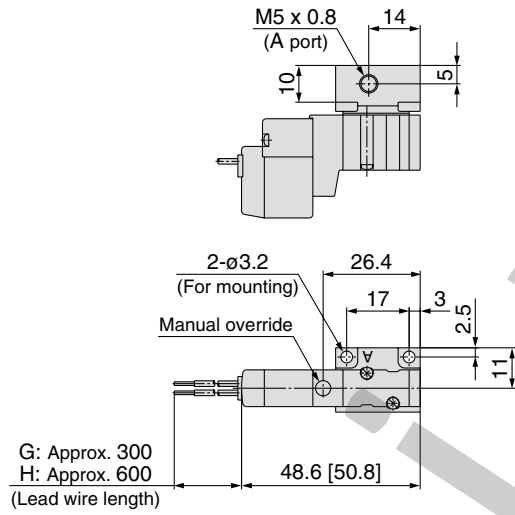

(Light/surge voltage suppressor)

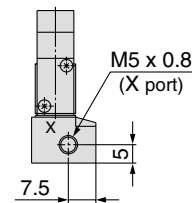
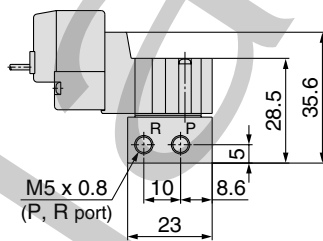
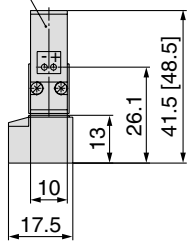

L plug connector (L):
SYJ3□4-□L□□-M5

M plug connector (M):
SYJ3□4-□M□□-M5

M8 connector (W0):
SYJ3□4-□W0□□-M5

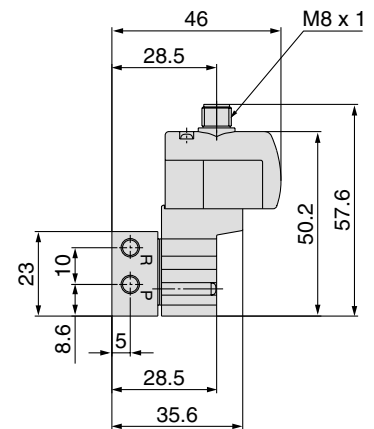
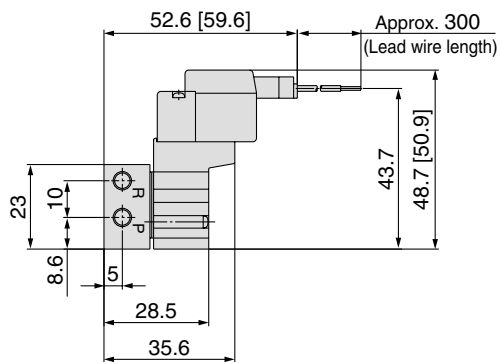
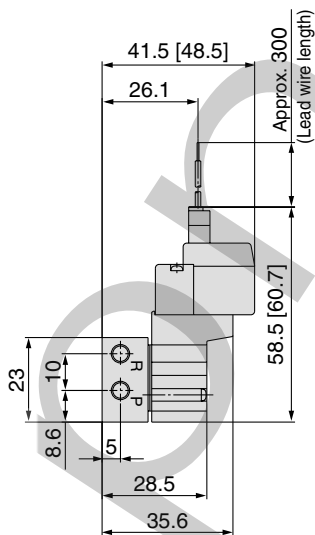

* Refer to the page 68 for dimensions with connector cable.

Series SYJ300 Manifold Specifications

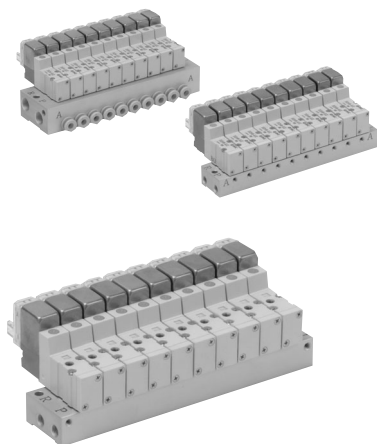

Manifold Specifications

Model	For internal pilot	Type 20	Type 41, S41	Type 42, S42
	For external pilot	Type 20R	—	Type 42R, S42R
Manifold type	Single base/B mount			
P (SUP), R (EXH)	Common SUP/Common EXH			
Valve stations	2 to 20 stations			
A port Porting specifications	Location	Valve	Base	
	Direction	Top	Side	
Port size	P, R port	M5 x 0.8 1/8	M5 x 0.8	1/8
		A port	M3 x 0.5	M3 x 0.5 M5 x 0.8 C4 (One-touch fitting ø4)
	X port ^{Note)}	M5 x 0.8	—	M5 x 0.8

Note) Only for external pilot

Flow Characteristics

Manifold			Port size		Flow characteristics						Effective area (mm ²)
					1R2 (PRA)			2R3 (ARR)			
1(P), 3(R) Port	2(A) Port	C [dm ³ /(s bar)]	b	Cv	C [dm ³ /(s bar)]	b	Cv				
Body ported for internal pilot	Type SS3YJ3-20 SYJ3□2	M5 x 0.8	M3 x 0.5	—	—	—	—	—	—	—	0.9
Base mounted for internal pilot	Type SS3YJ3-41 S41 SYJ3□4	M5 x 0.8	M3 x 0.5	—	—	—	—	—	—	—	1.5
	Type SS3YJ3-42-M5 SYJ3□4	1/8	M5 x 0.8 C4	0.31 0.33	0.17 0.36	0.075 0.086	0.32 0.33	0.11 0.2	0.072 0.082	—	—
	Type SS3YJ3-S42-M5 SYJ3□4	1/8	M5 x 0.8 C4	0.32 0.35	0.3 0.17	0.079 0.082	0.33 0.35	0.35 0.26	0.086 0.086	—	—
	Type SS3YJ3-S42-C4 SYJ3□4	1/8	M5 x 0.8 C4	0.32 0.35	0.3 0.17	0.079 0.082	0.33 0.35	0.35 0.26	0.086 0.086	—	—
Body ported for external pilot	Type SS3YJ3-20R SYJ3□2R	1/8	M3 x 0.5	—	—	—	—	—	—	—	0.9
Base mounted for external pilot	Type SS3YJ3-42R-M5 SYJ3□4R	1/8	M5 x 0.8 C4	0.31 0.33	0.17 0.36	0.075 0.086	0.32 0.33	0.11 0.20	0.072 0.082	—	—
	Type SS3YJ3-S42R-M5 SYJ3□4R	1/8	M5 x 0.8 C4	0.32 0.35	0.3 0.17	0.079 0.082	0.33 0.35	0.35 0.26	0.086 0.086	—	—
	Type SS3YJ3-S42R-C4 SYJ3□4R	1/8	M5 x 0.8 C4	0.32 0.35	0.3 0.17	0.079 0.082	0.33 0.35	0.35 0.26	0.086 0.086	—	—
	Type SS3YJ3-S42R-C4 SYJ3□4R	1/8	M5 x 0.8 C4	0.32 0.35	0.3 0.17	0.079 0.082	0.33 0.35	0.35 0.26	0.086 0.086	—	—

Note) Value at manifold base mounted, 2 position single acting

How to Order Manifold (Example)

Instruct by specifying the valves and blanking plate assembly to be mounted on the manifold along with the manifold base model no.

(Example)

SS3YJ3-20-03 1 set (manifold base) SS3YJ3-42R-03-C4 1 set (manifold base)
 *SYJ312-5LZ-M3 2 sets (valve) SYJ314R-5G 2 sets (valve)
 *SYJ300-10-1A 1 set (blanking plate assembly) SYJ300-10-2A 1 set (blanking plate assembly)

↳ The asterisk denotes the symbol for assembly. Prefix it to the part nos. of the solenoid valve, etc.

Combinations of Solenoid Valve, Manifold Gasket and Manifold Base

**Body ported
(Type SYJ3□2(R))**

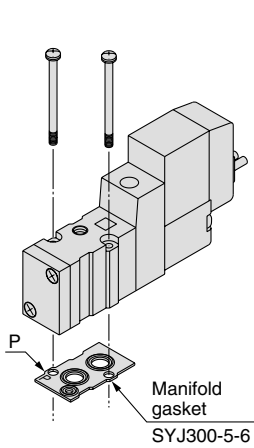

Applicable base

- SS3YJ3-20 | Manifold
- SS3YJ3-20R | base

**Base mounted
(Type SYJ3□4(R))**

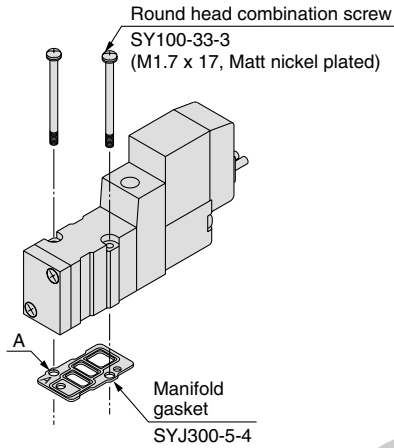

Applicable base

- Sub-plate**
 - SS3YJ3-41
 - SS3YJ3-S41
 - SS3YJ3-42
 - SS3YJ3-S42
 - SS3YJ3-42R
 - SS3YJ3-S42R
- } Manifold base

Blanking Plate Assembly

Model no.: SYJ300-10-1A

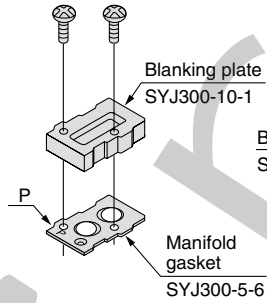

Applicable base

- SS3YJ3-20 | Manifold
- SS3YJ3-20R | base

Model no.: SYJ300-10-2A

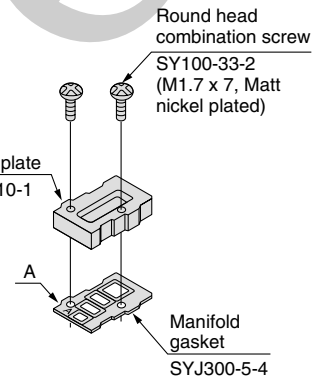

Applicable base

- Sub-plate**
 - SS3YJ3-41
 - SS3YJ3-S41
 - SS3YJ3-42
 - SS3YJ3-S42
 - SS3YJ3-42R
 - SS3YJ3-S42R
- } Manifold base

⚠ Caution

Mounting screw tightening torques

M1.7: 0.12 N·m

Use caution to the assembly orientation for solenoid valves, gasket, and optional parts.

Series SYJ300

Manifold for Internal Pilot Type

Type 20

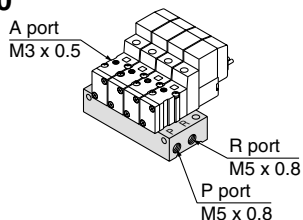

How to Order

SS3YJ3-20-05

Stations	
02	2 stations
:	:
20	20 stations

Bracket	
Nil	Without bracket
F	With bracket

Applicable solenoid valve
 SYJ312-□□□□-M3
 SYJ312M-□□□□-M3
 SYJ322-□□□□-M3
 SYJ322M-□□□□-M3

Applicable blanking plate assembly
 SYJ300-10-1A

Note) For more than 10 stations, supply air to both sides of P port and exhaust air from both sides of R port.

Type 41

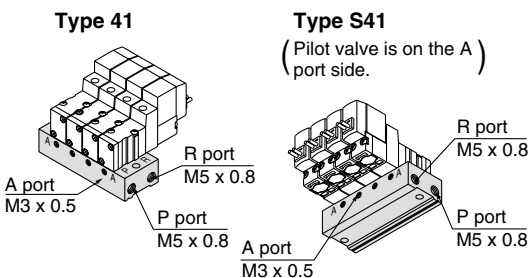

How to Order

SS3YJ3-41-05-M3

Valve mounting direction	
Nil	Pilot valve is opposite the A port side.
S	Pilot valve is on the A port side.

Stations	
02	2 stations
:	:
20	20 stations

Applicable solenoid valve
 SYJ314-□□□□
 SYJ314M-□□□□
 SYJ324-□□□□
 SYJ324M-□□□□

Applicable blanking plate assembly
 SYJ300-10-2A

Note) For more than 10 stations, supply air to both sides of P port and exhaust air from both sides of R port.

Type 42

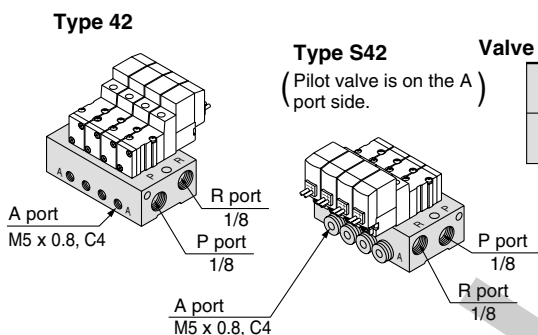

How to Order

SS3YJ3-42-05-M5

Valve mounting direction	
Nil	Pilot valve is opposite the A port side.
S	Pilot valve is on the A port side.

Stations	
02	2 stations
:	:
20	20 stations

Applicable solenoid valve
 SYJ314-□□□□
 SYJ314M-□□□□
 SYJ324-□□□□
 SYJ324M-□□□□

Applicable blanking plate assembly
 SYJ300-10-2A

A port size	
M5	M5 x 0.8
C4	ø4 one-touch fitting
N3	ø5/32" one-touch fitting

P, R port thread type	
Nil	Rc
F	G
N	NPT
T	NPTF

Note) For more than 8 stations, supply/exhaust air to/from both sides of P port and R port.

Manifold for External Pilot Type

Pilot valve pressure is supplied separately from the main valve pressure through the use of a separate supply port. It can be used in the vacuum (up to -100 kPa) or low pressure line with 0.15 MPa or less.

Type 20R

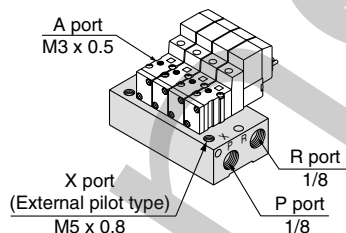

How to Order

SS3YJ3-20R-05

Stations	
02	2 stations
:	:
20	20 stations

P, R port thread type	
Nil	Rc
00F	G
00N	NPT
00T	NPTF

Applicable solenoid valve
 SYJ312R-□□□□
 SYJ322R-□□□□

Applicable blanking plate assembly
 SYJ300-10-1A

Note) For more than 10 stations, supply/exhaust air to/from both sides of P port and R port.

Type 42R

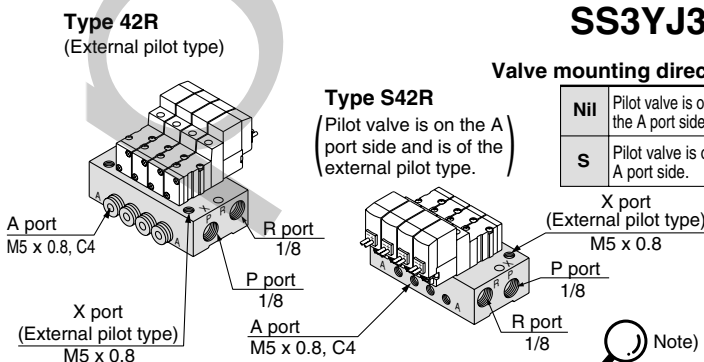

How to Order

SS3YJ3-42R-05-M5

Valve mounting direction	
Nil	Pilot valve is opposite the A port side.
S	Pilot valve is on the A port side.

Stations	
02	2 stations
:	:
20	20 stations

Applicable solenoid valve
 SYJ314R-□□□□
 SYJ324R-□□□□

Applicable blanking plate assembly
 SYJ300-10-2A

A port size	
M5	M5 x 0.8
C4	ø4 one-touch fitting
N3	ø5/32" one-touch fitting

P, R port thread type	
Nil	Rc
F	G
N	NPT
T	NPTF

Note) For more than 8 stations, supply/exhaust air to/from both sides of P port and R port.

Type 20 Manifold: Top Ported/SS3YJ3-20- Stations -00□ (-F)

* [] for AC

Grommet (G)

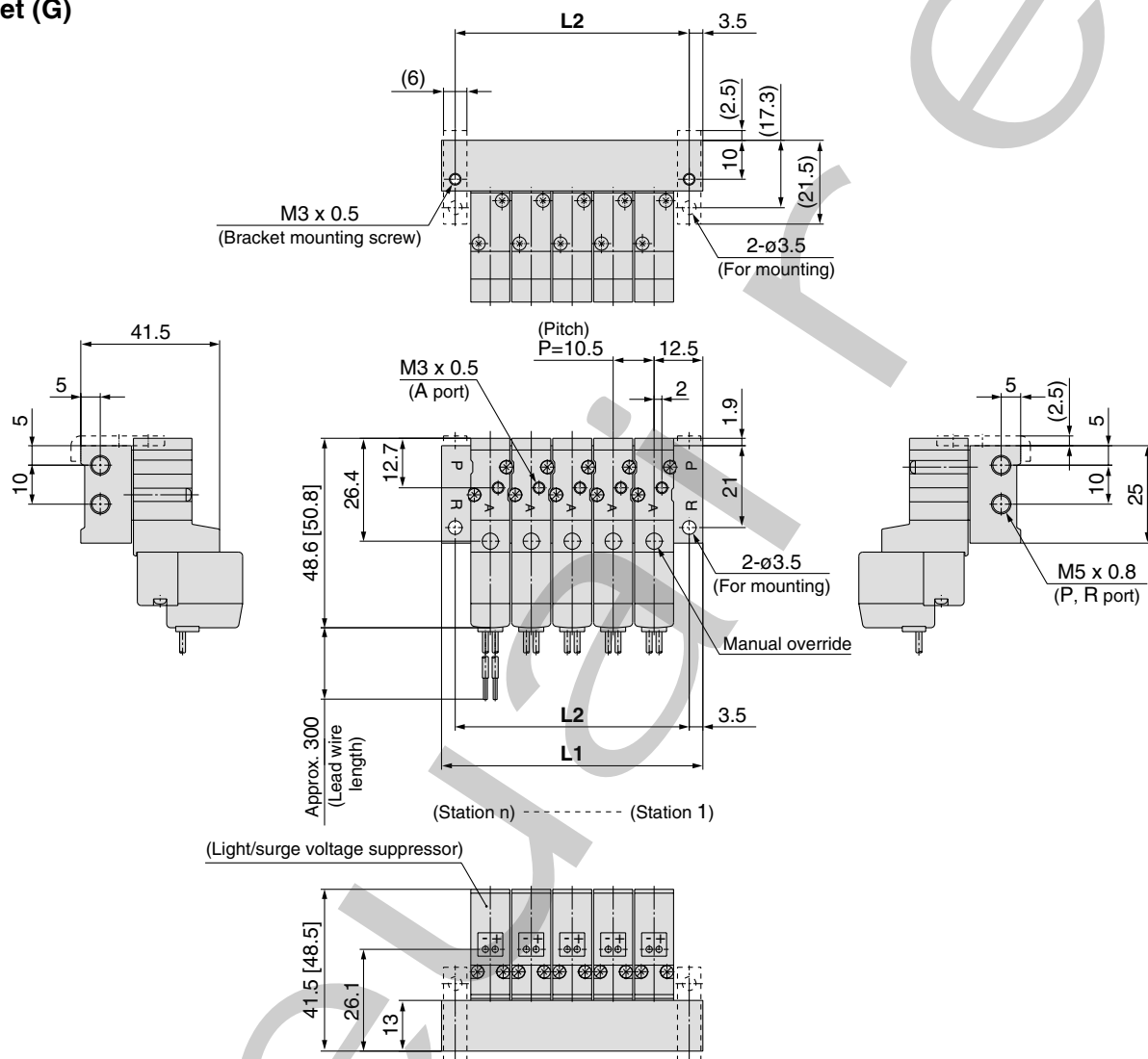

L plug connector (L)

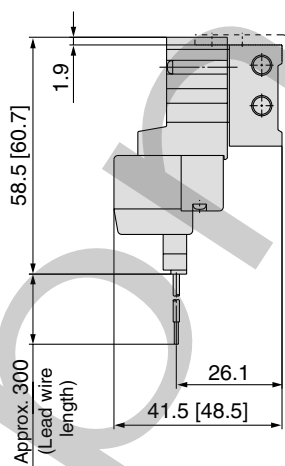

M plug connector (M)

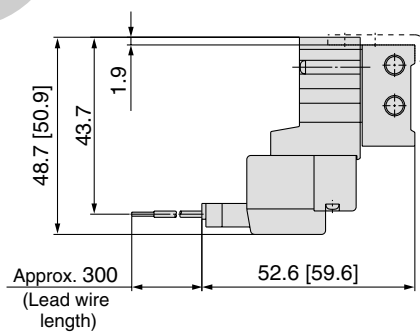

M8 connector (W0)

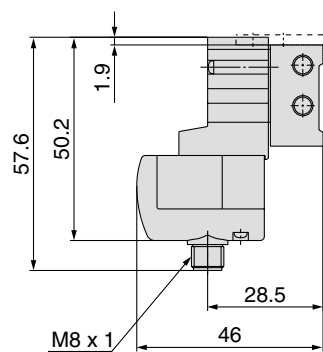

* Refer to the page 68 for dimensions with connector cable.

Station n	2	3	4	5	6	7	8	9	10	11	12	13	14	15	16	17	18	19	20
L1	35.5	46	56.5	67	77.5	88	98.5	109	119.5	130	140.5	151	161.5	172	182.5	193	203.5	214	224.5
L2	28.5	39	49.5	60	70.5	81	91.5	102	112.5	123	133.5	144	154.5	165	175.5	186	196.5	207	217.5

Series SYJ300

Type 41 Manifold: Side Ported/SS3YJ3-41- Stations -M3

* [] for AC

Grommet (G)

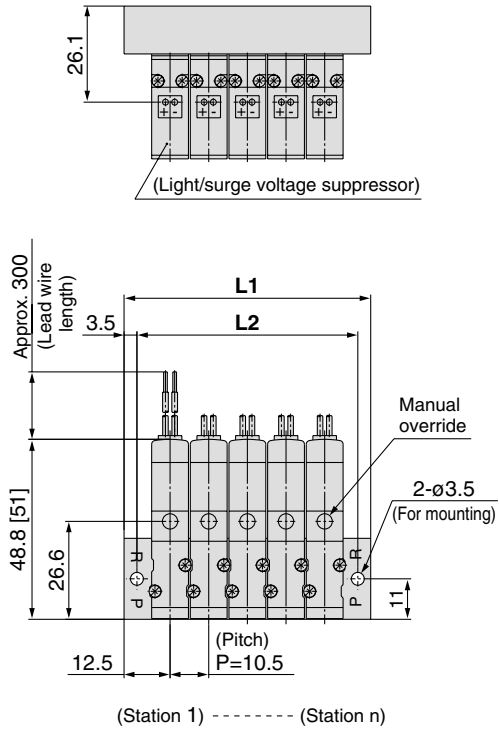

Type 41 Manifold: Side Ported

(Pilot valve is on the A port side) /

SS3YJ3-S41- Stations -M3

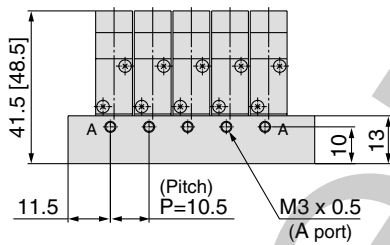
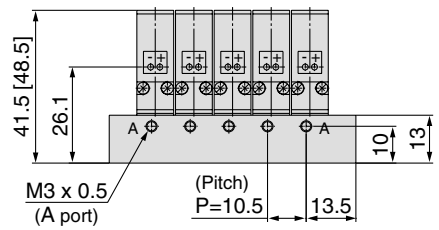
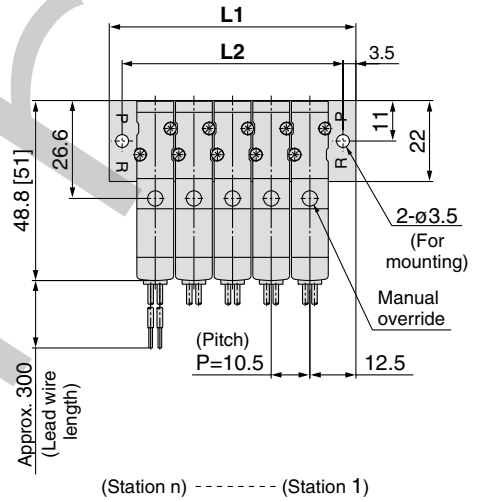

L plug connector (L)

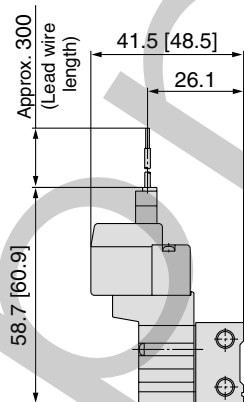

M plug connector (M)

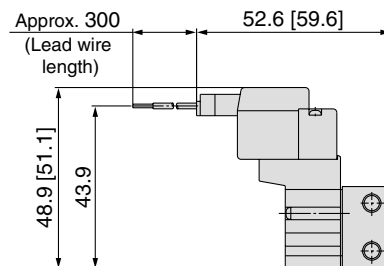

M8 connector (W0)

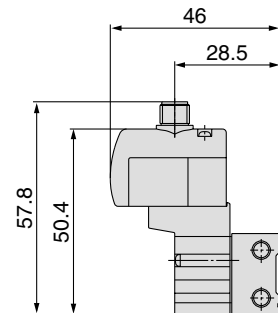

* Refer to the page 68 for dimensions with connector cable.

Station n	Station 2	3	4	5	6	7	8	9	10	11	12	13	14	15	16	17	18	19	Station 20
L1	35.5	46	56.5	67	77.5	88	98.5	109	119.5	130	140.5	151	161.5	172	182.5	193	203.5	214	224.5
L2	28.5	39	49.5	60	70.5	81	91.5	102	112.5	123	133.5	144	154.5	165	175.5	186	196.5	207	217.5

Type 42 Manifold: Side Ported/SS3YJ3-42- Stations -M5, C4 N3

* [] for AC

Grommet (G)
For M5

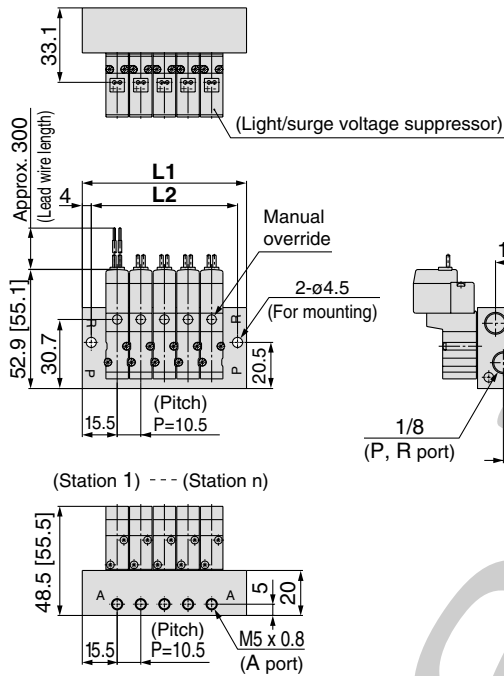

For C4 N3 (Built-in one-touch fitting)

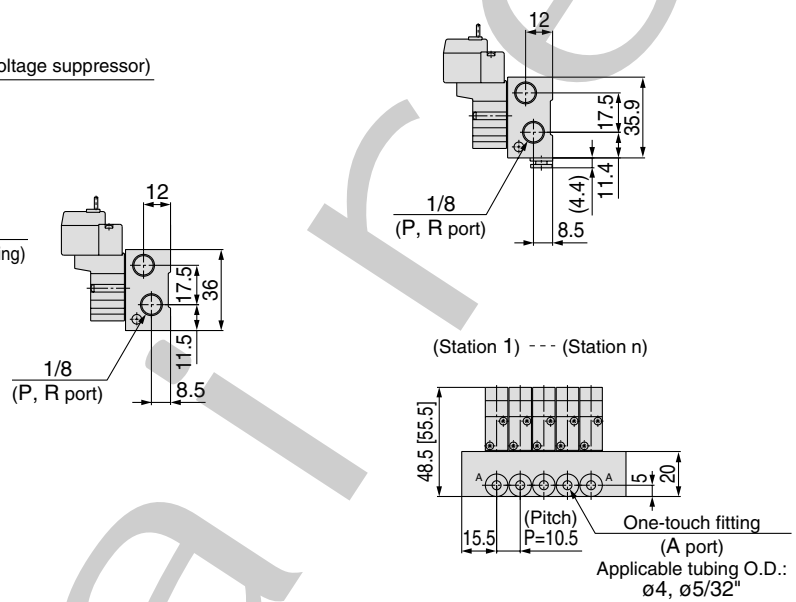

L plug connector (L)

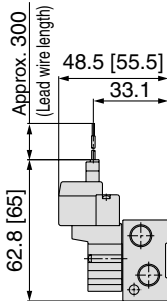

M plug connector (M)

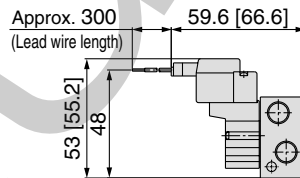

M8 connector (W0)

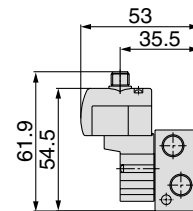

* Refer to the page 68 for dimensions with connector cable.

Type 42 Manifold: Side Ported (Pilot valve is on the A port side) / SS3YJ3-S42- Stations -M5, C4 N3

Grommet (G)
For M5

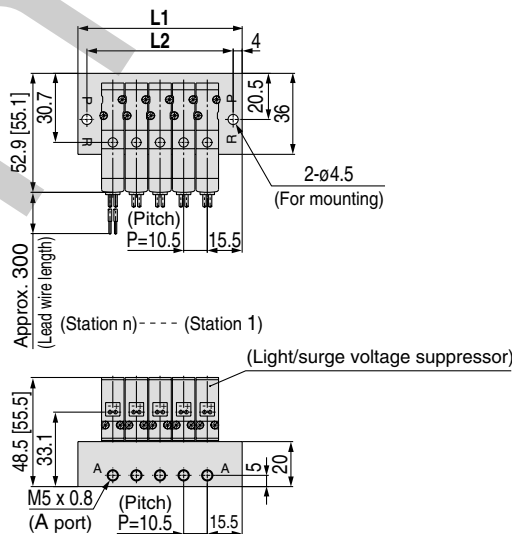

For C4 N3 (Built-in one-touch fitting)

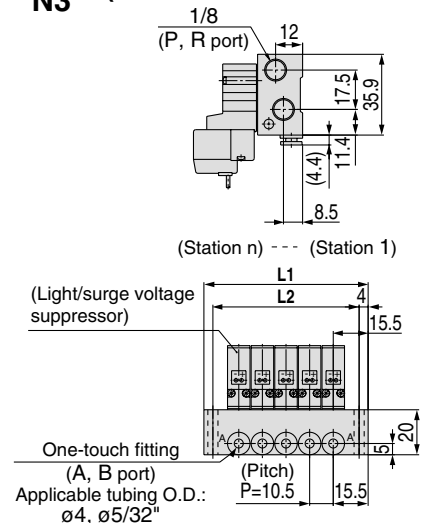

Station n	Station 2	3	4	5	6	7	8	9	10	11	12	13	14	15	16	17	18	19	Station 20
L1	41.5	52	62.5	73	83.5	94	104.5	115	125.5	136	146.5	157	167.5	178	188.5	199	209.5	220	230.5
L2	33.5	44	54.5	65	75.5	86	96.5	107	117.5	128	138.5	149	159.5	170	180.5	191	201.5	212	222.5

Series SYJ300

Type 20R Manifold: Top Ported (External Pilot Type)/SS3YJ3-20R-**Stations**-00 [] for AC

Grommet (G)

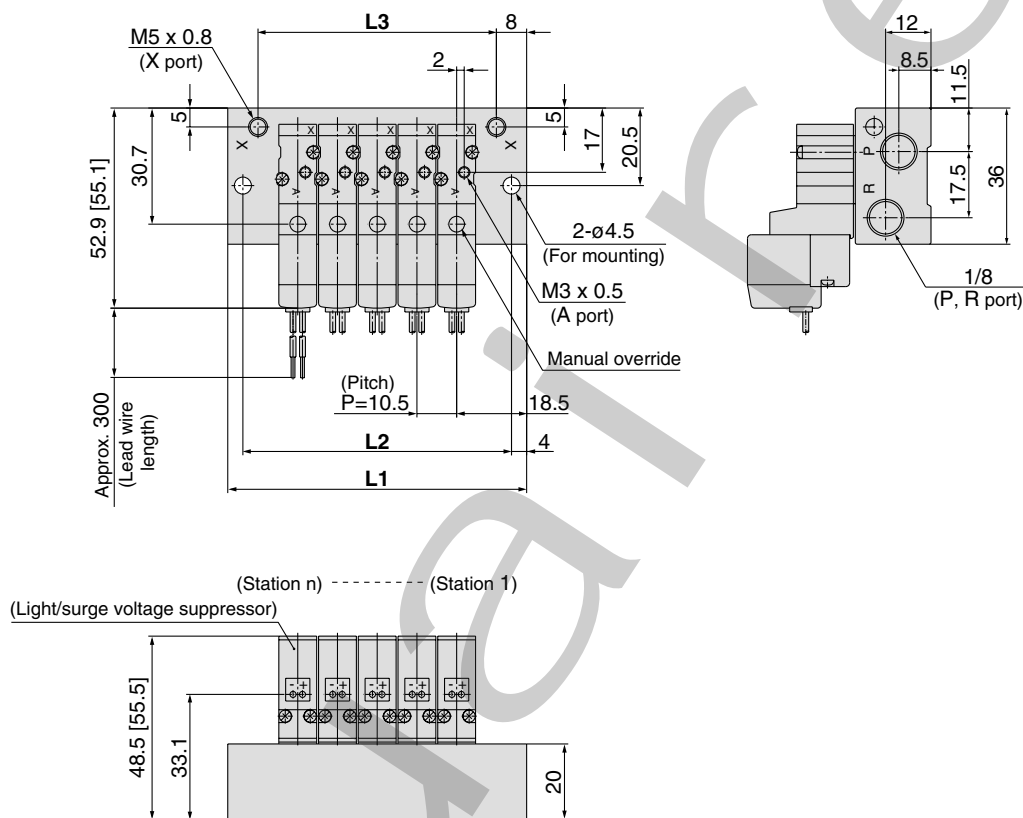

L plug connector (L)

M plug connector (M)

M8 connector (W0)

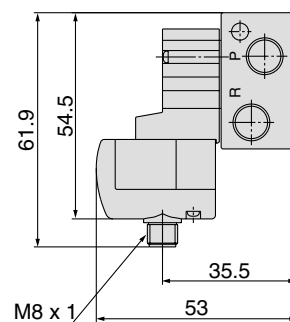
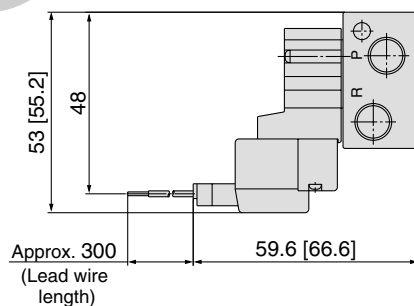
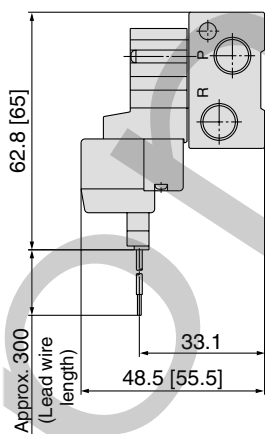

* Refer to the page 68 for dimensions with connector cable.

Station n	Station 2	3	4	5	6	7	8	9	10	11	12	13	14	15	16	17	18	19	Station 20
L1	47.5	58	68.5	79	89.5	100	110.5	121	131.5	142	152.5	163	173.5	184	194.5	205	215.5	226	236.5
L2	39.5	50	60.5	71	81.5	92	102.5	113	123.5	134	144.5	155	165.5	176	186.5	197	207.5	218	228.5
L3	31.5	42	52.5	63	73.5	84	94.5	105	115.5	126	136.5	147	157.5	168	178.5	189	199.5	210	220.5



Type 42R Manifold: Side Ported (External Pilot Type)/SS3YJ3-42R- Stations -M5, $\frac{C4}{N3}$ * [] for AC

Grommet (G)
For M5

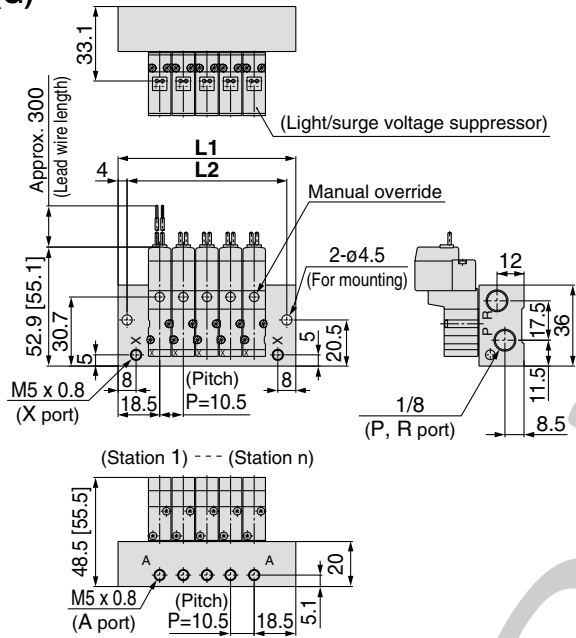

For $\frac{C4}{N3}$ (Built-in one-touch fitting)

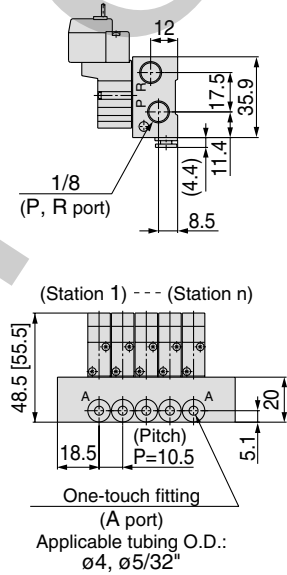

L plug connector (L)

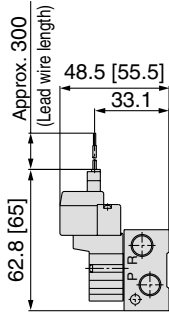

M plug connector (M)

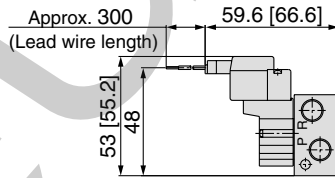

M8 connector (W0)

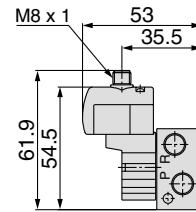

* Refer to the page 68 for dimensions with connector cable.

Type S42R Manifold: Side Ported (Pilot valve is on the A port side) / SS3YJ3-S42R- Stations -M5, $\frac{C4}{N3}$

Grommet (G)
For M5

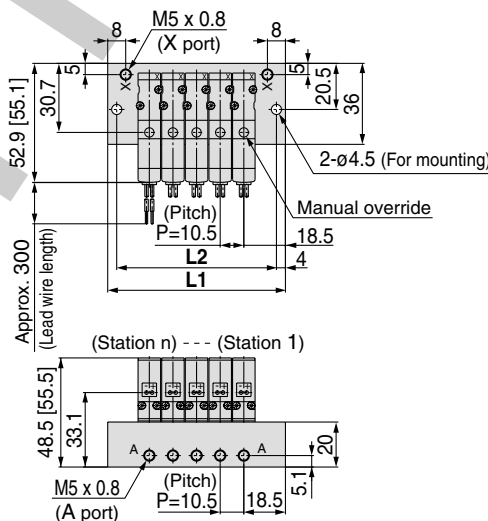

For $\frac{C4}{N3}$ (Built-in one-touch fitting)

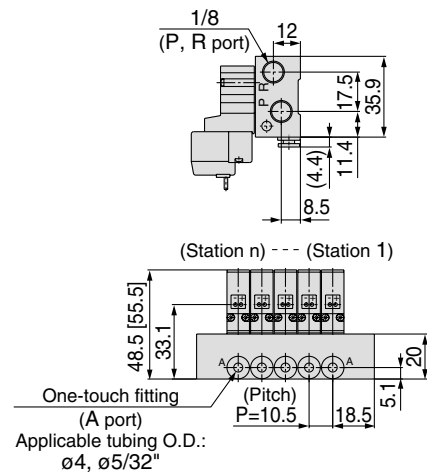

Station n	Station 2	3	4	5	6	7	8	9	10	11	12	13	14	15	16	17	18	19	Station 20
L1	47.5	58	68.5	79	89.5	100	110.5	121	131.5	142	152.5	163	173.5	184	194.5	205	215.5	226	236.5
L2	39.5	50	60.5	71	81.5	92	102.5	113	123.5	134	144.5	155	165.5	176	186.5	197	207.5	218	228.5