

Conforming to OSHA Standard Pressure Relief 3 Port Valve with Locking Holes

New

RoHS

Weight 
Max. **60%**
Lighter
* VHS20

Sonic
Conductance
C[dm³/s·bar] 
Max. **45%**
Up

**Energy
Saving**
Zero blow-by of the
air during switching
of the handle



Safety Measure

Double action



With locking holes



With the indicator window



Combination with a (modular style) F.R.L. is possible.

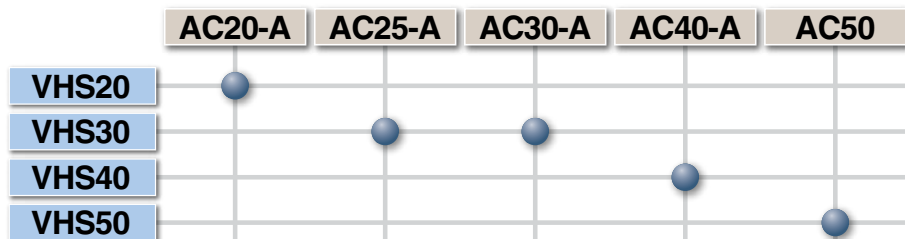

Single Action Series **VHS20/30/40/50**

Double Action Series **VHS2510/3510/4510/5510**

SMC
CAT.NAS13-10A

Single Action Series VHS20/30/40/50

Double Action Series VHS2510/3510/4510/5510

Lightweight

Resin handle and bonnet is standard.

Weight Maximum

60% Lighter

Material: Resin (Handle, bonnet)

76g

VHS20 (Aluminum body is standard): 190g



Handle: Flame resistant PBT (Equivalent to UL-94,V-0)

Bonnet: Flame resistant PBT (Equivalent to UL-94,V-0)

Body: Aluminum

VHS20-□A

Aluminum handle and bonnet type is available.



VHS20-□B

Safety Measure

Can prevent accidents caused by inadvertent air supply problems.

With the indicator window



The supply/exhaust status of the air flow can be verified at a glance in the indicator window.

SUP : Supply **EXH** : Exhaust

With locking holes



When in the exhaust position, the valve may be padlock secured. Prevents accidental start-ups while personnel are cleaning or servicing equipment.

OSHA standard (Occupational Safety and Health Administration Department of Labor)

For safety control, OSHA rule requires energy sources for certain equipment be turned off or disconnected and that the device either be locked or labelled with a warning tag.

Double action

Push the handle and then turn, **2-step** action prevents malfunction.

Step1

Push down the handle



Step2

Turn the handle



Options

With bracket

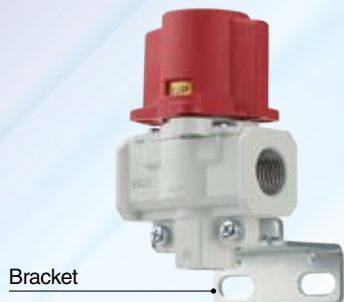

Built-in silencer (EXH port)

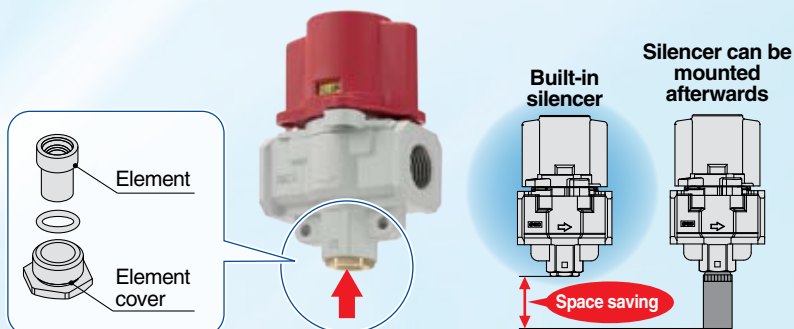

Made to Order (-X1)

Red body is available.



Variations

Port size 1/8, 1/4, and 3/8 are now available for double action type.

Single action	VHS20	VHS30	VHS40	VHS50
Double action	VHS2510	VHS3510	VHS4510	VHS5510
1/8	●			
1/4	●	●	●	
3/8		●	●	
1/2			●	
3/4			●	●
1				●



Conforming to OSHA Standard Pressure Relief 3 Port Valve with Locking Holes (Single Action)

Series VHS20/30/40/50



How to Order

Single action

VHS 40 - [] 04 A - BS - [] - []

Pressure relief 3 port valve

Body size

Symbol
20
30
40
50

Thread type

Nil	Rc
N	NPT
F	G

Port size

Symbol	Port size	Body size			
		20	30	40	50
01	1/8	●	—	—	—
02	1/4	●	●	●	—
03	3/8	—	●	●	—
04	1/2	—	—	●	—
06	3/4	—	—	●	●
10	1	—	—	—	●

Handle / Bonnet material

Symbol	Material
A	Flame resistant PBT
B	Aluminum

Made to Order

Symbol	Description
X1	Body: Red Note)

Note) Refer to Photo of X1 in Feature 2 for the appearance.

Semi-standard specifications

Symbol	Description
Nil	—
R	Flow direction: Right → Left
Z Note)	PSI as unit displayed on label

Note) Only for the NPT thread. Under the New Measurement Law, products for overseas use only (SI unit type for use in Japan).

Options

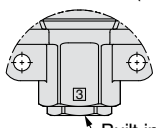
Symbol	Description
Nil	—
B	With bracket
S	Built-in silencer (EXH port)  Built-in silencer

A spacer or spacer with bracket is required if the valve is combined with modular F.R.L. Please order it separately.
VHS type can be ordered from How to Order of modular F.R.L. combination.

Pressure relief 3 port valve	Spacer part no.	Spacer with bracket part no.	Applicable air preparation equipment
VHS20	Y200-A	Y200T-A	AC20-A
VHS30	Y300-A	Y300T-A	AC25-A, AC30-A
VHS40	Y400-A	Y400T-A	AC40-A
VHS40-06	Y500-A	Y500T-A	AC40-06-A
VHS50	Y600-A	Y600T-A	AC50, AC55 Note), AC60 Note)

Note) VHS50 can be connected to AC55 and AC60.

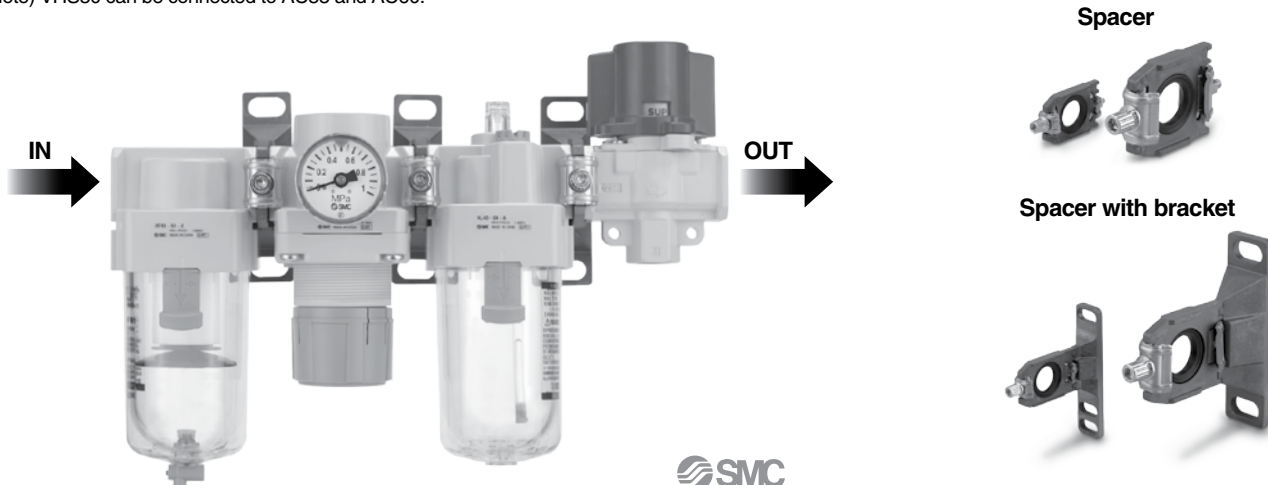

Specifications



JIS Symbol

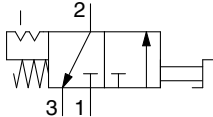

OSHA standard (Occupational Safety and Health Administration Department of Labor)

For safety control, OSHA rule requires energy sources for certain equipment be turned off or disconnected and that the device either be locked or labelled with a warning tag.

Standard specifications

Model	VHS20	VHS30	VHS40	VHS40-06	VHS50	
Fluid	Air					
Ambient and fluid temperature	23 to 140°F (-5 to 60°C) (No freezing)					
Proof pressure	218 psi (1.5 MPa)					
Operating pressure range	14.5 to 145 psi (0.1 to 1.0 MPa)					
Handle switching angle	90°					
Paint color (Standard)	Handle: Red Body: White					
Weight	A (Handle, bonnet: Flame resistant PBT)	76 g	127 g	247 g	293 g	532 g
	B (Handle, bonnet: Aluminum)	92 g	156 g	301 g	349 g	630 g

(1 g = 0.035 oz)

Flow-rate characteristics

Model	Port size		Flow-rate characteristics					
			IN→OUT			OUT→EXH		
			C(dm³/s-bar)	b	Cv	C(dm³/s-bar)	b	Cv
VHS20	1/8	1/8	2.4	0.43	0.65	2.5	0.39	0.69
	1/4		3.3	0.40	0.88	3.1	0.51	0.84
VHS30	1/4	1/4	6.4	0.45	1.7	6.2	0.38	1.7
	3/8		8.3	0.41	2.3	7.0	0.41	1.9
VHS40	1/4	3/8	7.3	0.49	2.0	8.5	0.35	2.3
	3/8		10.9	0.45	3.0	11.6	0.40	3.1
	1/2		14.2	0.39	3.8	13.3	0.43	3.6
VHS40-06	3/4	1/2	18.3	0.31	5.0	17.7	0.37	4.8
VHS50	3/4	1/2	23.8	0.41	6.4	21.8	0.41	5.9
	1		31.9	0.33	8.6	23.5	0.44	6.4

Construction

VHS20 to 50-A

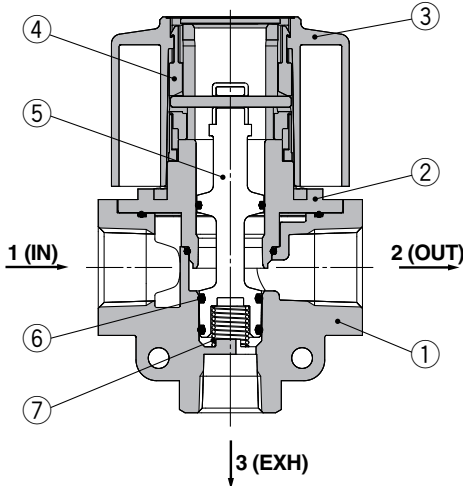

VHS20 to 50-B

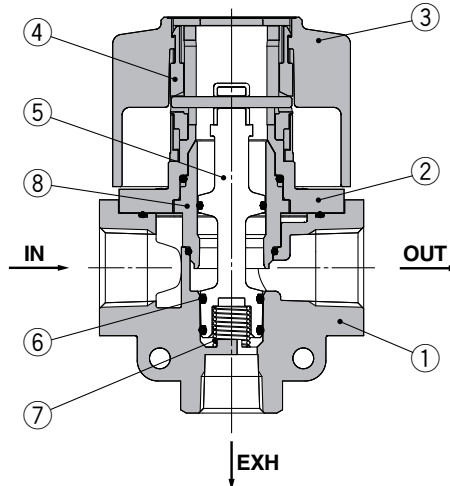

Built-in silencer (Option)

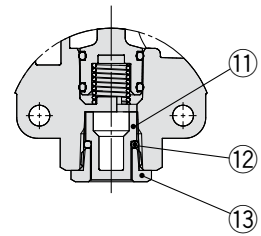

Cross section of EXH port

Component Parts

No.	Description	Material		Note
		VHS20 to 50-A	VHS20 to 50-B	
1	Body	ADC12		White
2	Bonnet	Flame resistant PBT (UL-94 Standard V-0 equivalent)	ADC12	White
3	Handle	Flame resistant PBT (UL-94 Standard V-0 equivalent)	ADC12	Red
4	Cam ring	POM		—
5	Spool	PBT		—
6	Spool O-ring	H-NBR		—
7	Spool spring	Stainless steel		—
8	Ferrule	POM		—

Option Part No.

Model	Bracket assembly part no. (Note 1)	Silencer assembly part no. (Note 2)
VHS20	VHS20PW-180AS	VHS20PW-190AS
VHS30	VHS30PW-180AS	VHS30PW-190AS
VHS40	VHS40PW-180AS	VHS40PW-190AS
VHS40-06	VHS40PW-180-06AS	VHS40PW-190-06AS
VHS50	VHS50PW-180AS	VHS50PW-190AS

Note 1) Bracket/1pc., mounting screw/2pcs.

Note 2) Element ①, element O-ring ②, element cover ③ 1pc. for each.

* The VHS series cannot be disassembled. Parts cannot be shipped separately.

Series VHS20/30/40/50

Dimensions

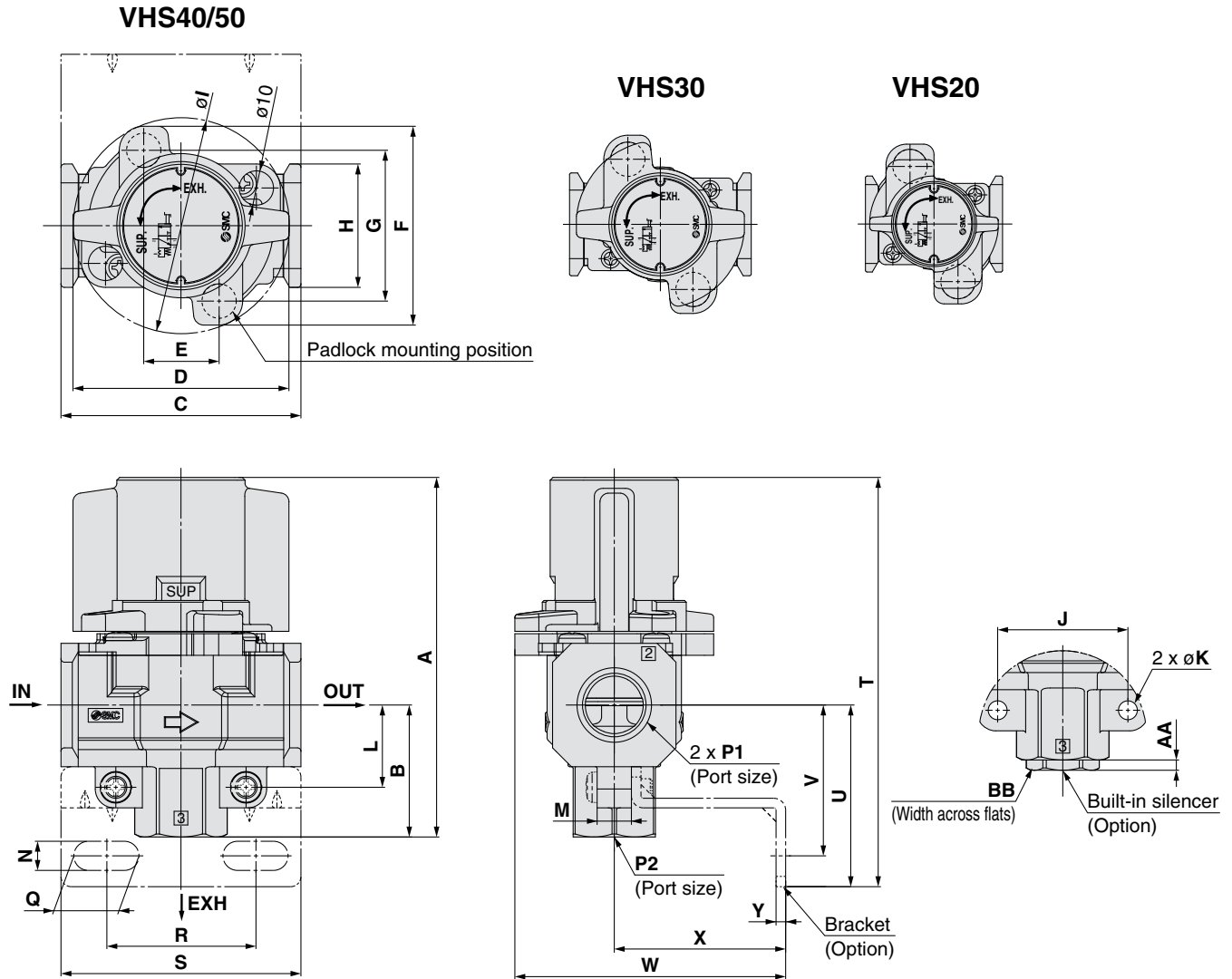

Dimensions

(mm)

Model	Standard specifications														
	P1	P2	A	B	C	D	E	F	G	H	I	J	K	L	M
VHS20	1/8, 1/4	1/8	66.4	22.3	40	37.5	14	46.6	33.6	28	37.5	24	4.5	14.8	9
VHS30	1/4, 3/8	1/4	80.3	29.4	53	49	19	52	38	30	49	30	4.5	19	9
VHS40	1/4, 3/8, 1/2	3/8	104.9	38.5	70	63	22	58	44	36	63	38	5.5	24	10
VHS40-06	3/4	1/2	110.4	42	75	63	22	58	44	44	63	43	5.5	26	10
VHS50	3/4, 1	1/2	134.3	53	90	76	26	76	61	53	81	50	6.5	31	12

Model	Options specifications											
	With bracket										Built-in silencer	
	N	Q	R	S	T	U	V	W	X	Y	AA	BB
VHS20	5.4	8.4	27	40	75.4	31.3	25.3	53.3	30	2.3	3	12
VHS30	6.5	10	36.5	53	90.9	40	33	67	41	2.3	3	14
VHS40	8.5	19	43.5	70	119.4	53	44	79	50	2.8	3	19
VHS40-06	8.5	19	43.5	70	123.4	55	46	79	50	2.8	4	22
VHS50	11	27.5	49.5	90	152.3	71	60	108	70	3.2	4	22

Conforming to OSHA Standard Pressure Relief 3 Port Valve with Locking Holes (Double Action)

RoHS

Series VHS2510/3510/4510/5510

How to Order

Double action

VHS 4 510 - [] 04 A - BS - [] - []

Pressure relief 3 port valve

Body size

Symbol
2
3
4
5

Double action

Thread type

Nil	Rc
N	NPT
F	G

Port size

Symbol	Port size	Body size			
		2	3	4	5
01	1/8	●	—	—	—
02	1/4	●	●	●	—
03	3/8	—	●	●	—
04	1/2	—	—	●	—
06	3/4	—	—	●	●
10	1	—	—	—	●

Handle / Bonnet material

Symbol	Material
A	Flame resistant PBT
B	Aluminum

Made to Order

Symbol	Description
X1	Body: Red Note)

Note) Refer to Photo of X1 in Feature 2 for the appearance.

Semi-standard specifications

Symbol	Description
Nil	—
R	Flow direction: Right → Left
Z Note)	PSI as unit displayed on label

Note) Only for the NPT thread. Under the New Measurement Law, products for overseas use only (SI unit type for use in Japan).

Options

Symbol	Description
Nil	—
B	With bracket
S	Built-in silencer (EXH port)

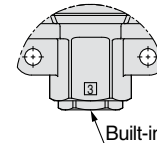

A spacer or spacer with bracket is required if the valve is combined with modular F.R.L. Please order it separately.

Pressure relief 3 port valve	Spacer part no.	Spacer with bracket part no.	Applicable air preparation equipment
VHS2510	Y200-A	Y200T-A	AC20-A
VHS3510	Y300-A	Y300T-A	AC25-A, AC30-A
VHS4510	Y400-A	Y400T-A	AC40-A
VHS4510-06	Y500-A	Y500T-A	AC40-06-A
VHS5510	Y600-A	Y600T-A	AC50, AC55 Note), AC60 Note)

Note) VHS5510 can be connected to AC55 and AC60.

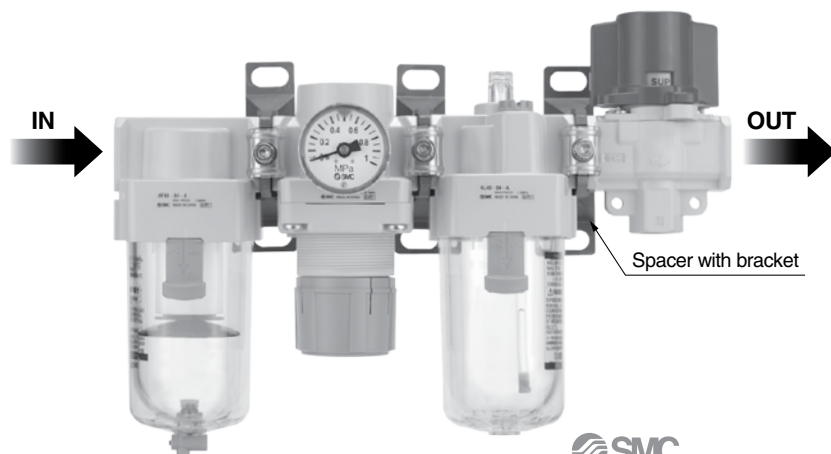

Spacer



Spacer with bracket

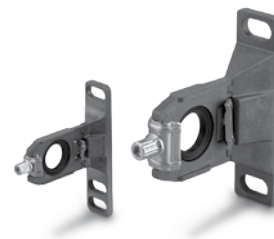

Series VHS2510/3510/4510/5510

Specifications

Standard specifications

Model	VHS2510	VHS3510	VHS4510	VHS4510-06	VHS5510	
Fluid	Air					
Ambient and fluid temperature	23 to 140°F (-5 to 60°C) (No freezing)					
Proof pressure	218 psi (1.5 MPa)					
Operating pressure range	14.5 to 145 psi (0.1 to 1.0 MPa)					
Handle switching angle	90°					
Paint color (Standard)	Handle: Red Body: White					
Weight	A (Handle, bonnet: Flame resistant PBT)	77 g	129 g	250 g	296 g	536 g
	B (Handle, bonnet: Aluminum)	93 g	158 g	304 g	352 g	635 g

(1 g = 0.035 oz)

Flow-rate characteristics

Model	Port size		Flow-rate characteristics					
	IN, OUT	EXH	IN→OUT			OUT→EXH		
			C(dm ³ /s-bar)	b	Cv	C(dm ³ /s-bar)	b	Cv
VHS2510	1/8	1/8	2.4	0.43	0.65	2.5	0.39	0.69
	1/4		3.3	0.40	0.88	3.1	0.51	0.84
VHS3510	1/4	1/4	6.4	0.45	1.7	6.2	0.38	1.7
	3/8		8.3	0.41	2.3	7.0	0.41	1.9
VHS4510	1/4	3/8	7.3	0.49	2.0	8.5	0.35	2.3
	3/8		10.9	0.45	3.0	11.6	0.40	3.1
	1/2		14.2	0.39	3.8	13.3	0.43	3.6
VHS4510-06	3/4	1/2	18.3	0.31	5.0	17.7	0.37	4.8
VHS5510	3/4	1/2	23.8	0.41	6.4	21.8	0.41	5.9
	1		31.9	0.33	8.6	23.5	0.44	6.4

JIS Symbol

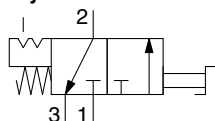

OSHA standard (Occupational Safety and Health Administration Department of Labor)

For safety control, OSHA rule requires energy sources for certain equipment be turned off or disconnected and that the device either be locked or labelled with a warning tag.

Construction

VHS2510 to 5510-A

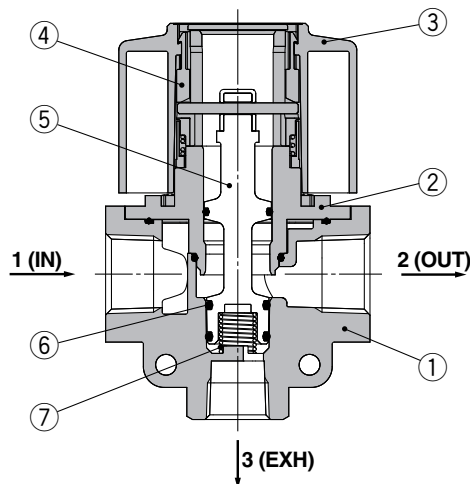

VHS2510 to 5510-B

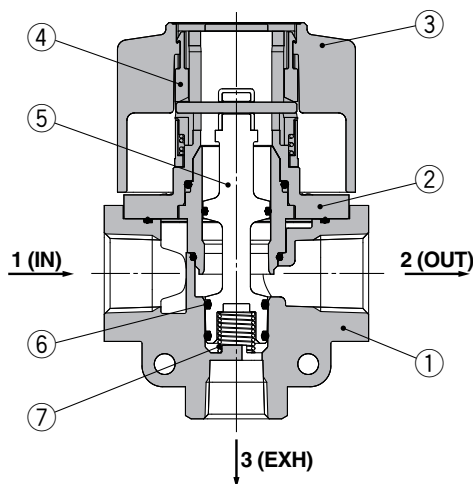

Built-in silencer (Option)

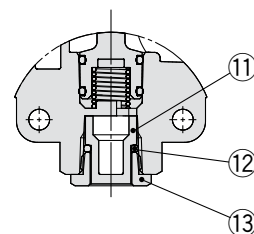

Cross section of EXH port

Component Parts

No.	Description	Material		Note
		VHS2510 to 5510-A	VHS2510 to 5510-B	
1	Body	ADC12		White
2	Bonnet	Flame resistant PBT (UL-94 Standard V-0 equivalent)	ADC12	White
3	Handle	Flame resistant PBT (UL-94 Standard V-0 equivalent)	ADC12	Red
4	Cam ring	POM		—
5	Spool	PBT		—
6	Spool O-ring	H-NBR		—
7	Spool spring	Stainless steel		—
8	Ferrule	POM		—

* The VHS series cannot be disassembled. Parts cannot be shipped separately.

Option Part No.

Model	Bracket assembly part no. Note 1)	Bracket assembly part no. Note 2)
VHS2510	VHS20PW-180AS	VHS20PW-190AS
VHS3510	VHS30PW-180AS	VHS30PW-190AS
VHS4510	VHS40PW-180AS	VHS40PW-190AS
VHS4510-06	VHS40PW-180-06AS	VHS40PW-190-06AS
VHS5510	VHS50PW-180AS	VHS50PW-190AS

Note 1) Bracket/1pc., mounting screw/2pcs.

Note 2) Element ⑪, element O-ring ⑫, element cover ⑬ 1pc. for each.

Dimensions

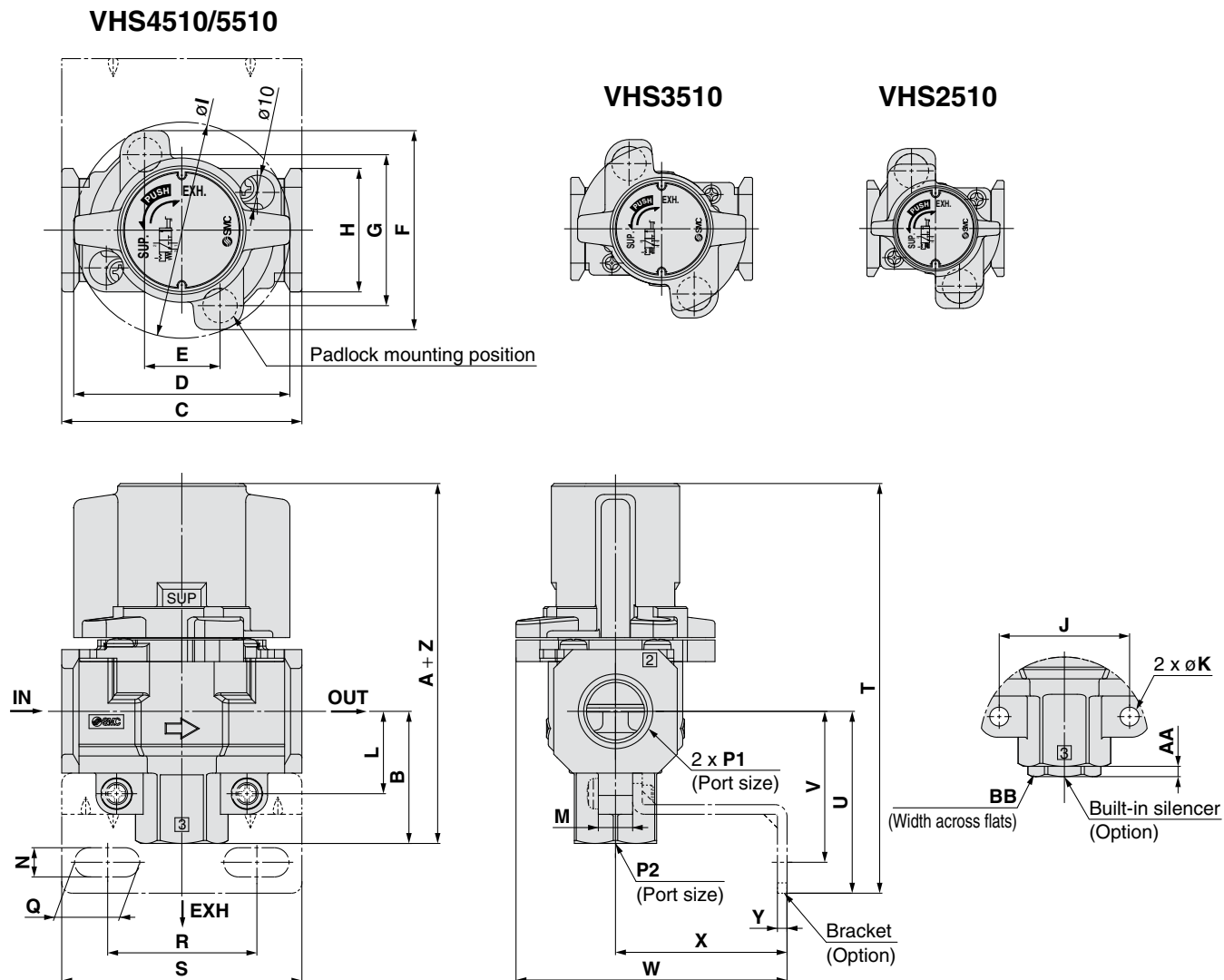

Dimensions

(mm)

Model	Standard specifications															
	P1	P2	A	B	C	D	E	F	G	H	I	J	K	L	M	Z
VHS2510	1/8, 1/4	1/8	66.4	22.3	40	37.5	14	46.6	33.6	28	37.5	24	4.5	14.8	9	3.2
VHS3510	1/4, 3/8	1/4	80.3	29.4	53	49	19	52	38	30	49	30	4.5	19	9	3.2
VHS4510	1/4, 3/8, 1/2	3/8	104.9	38.5	70	63	22	58	44	36	63	38	5.5	24	10	4.2
VHS4510-06	3/4	1/2	110.4	42	75	63	22	58	44	44	63	43	5.5	26	10	4.2
VHS5510	3/4, 1	1/2	134.3	53	90	76	26	76	61	53	81	50	6.5	31	12	4.2

Model	Options specifications											
	With bracket										Built-in silencer	
	N	Q	R	S	T	U	V	W	X	Y	AA	BB
VHS2510	5.4	8.4	27	40	75.4	31.3	25.3	53.3	30	2.3	3	12
VHS3510	6.5	10	36.5	53	90.9	40	33	67	41	2.3	3	14
VHS4510	8.5	19	43.5	70	119.4	53	44	79	50	2.8	3	19
VHS4510-06	8.5	19	43.5	70	123.4	55	46	79	50	2.8	4	22
VHS5510	11	27.5	49.5	90	152.3	71	60	108	70	3.2	4	22



Series VHS20/30/40/50

Series VHS2510/3510/4510/5510 Specific Product Precautions 1

Be sure to read before handling. Refer to back cover for Safety Instructions and "Handling Precautions for SMC Products" (M-E03-3) for 3/4/5 Port Solenoid Valve Precautions.

Precautions on Design

⚠ Warning

1. Please consult with SMC in cases where the ambient environment does not permit leakage or if fluid other than air is used.
2. Do not apply negative pressure. It may result in malfunction.
3. Do not supply air pressure from ports other than the 1 (P) port.

The valve will malfunction when air pressure is supplied from other ports.

Selection

⚠ Warning

1. In some cases, mineral oil grease used for internal parts and sealant may be carried to the output side.

Please contact SMC if this causes any inconvenience in use.

Installation and Adjustment

⚠ Warning

1. Confirm the symbols "1" and "2" before the valve is connected. The port marked "1" is the air inlet and the port marked "2" is the outlet.

Pressurization is only possible via the inlet port (1). Reverse connection may cause malfunction. The port symbols and corresponding piping types are shown in the table below.

Port symbol	Piping type
1	Inlet
2	Outlet
3	Exhaust

⚠ Caution

1. The valve must be switched to each position instantly and securely. Stopping the knob between the extreme positions may cause malfunction.
2. Do not remove the mounting screws from the bonnet.

As this may cause malfunction.

Piping

⚠ Warning

1. The port marked with an arrow (Δ) is the 1 (P) port (IN) and one on the opposite side is the 2 (A) port (OUT).

The port at a right angle to them is the 3 (R) port (EXH). Be sure to confirm before connecting since erroneous connection will cause malfunction.

Piping

⚠ Warning

2. Before piping is connected, the pipes should be thoroughly blown through with air (flushing) or washed to remove chips, cutting oil and other debris from inside.

Should they remain, they could cause malfunction.

3. When connecting pipes and fittings, etc., be sure that neither chips from the pipe threads nor sealing material get inside the valve.

When using sealant tape, leave 1.5 to 2 thread ridges exposed at the end of the pipe/fitting.

4. When screwing a piping component into the valve, secure the female threaded side and apply the recommended tightening torque.

Under tightening may result in loosening or sealing failure while over tightening may cause damage to threads and other problems.

Recommended tightening torque

Unit: lbf-ft (N-m)

Connection thread	1/8	1/4	3/8	1/2	3/4	1
Torque	5.2 to 6.6 (7 to 9)	8.9 to 10.3 (12 to 14)	16.2 to 17.7 (22 to 24)	20.7 to 22.1 (28 to 30)	20.7 to 22.1 (28 to 30)	26.6 to 28.0 (36 to 38)

Air Supply

⚠ Warning

1. Use clean air.

Do not use compressed air which contains chemicals, synthetic oils containing organic solvents, salts or corrosive gases, etc., as this can cause damage or malfunction.

2. Install an air dryer or after cooler on the upstream side of the pressure release 3 port valve because air containing excessive drainage may cause malfunction.

⚠ Caution

1. Install an air filter of 5 μm or less filtration on the inlet side.
2. Install a mist separator on the inlet side to remove carbon powder from the compressor or other equipment. An excessive amount of carbon dust ingress via the inlet may cause the valve to malfunction.

Refer to "SMC Air Preparation System" for further details on compressed air quality.

Operating Environment

⚠ Warning

1. Do not use valves where there is direct contact with, or in atmospheres of, corrosive gases, chemicals, salt water, water or steam.



Series VHS20/30/40/50

Series VHS2510/3510/4510/5510 Specific Product Precautions 2

Be sure to read before handling. Refer to back cover for Safety Instructions and "Handling Precautions for SMC Products" (M-E03-3) for 3/4/5 Port Solenoid Valve Precautions.

Operating Environment

Warning

2. Do not use in an explosive atmosphere.?
3. Do not use in locations subject to vibration or impact. Confirm the specifications for each series.
4. A protective cover should be used to shield valves from direct sunlight.
5. Shield valves from radiated heat generated by nearby heat sources.
6. Employ suitable protective measures in locations where there is contact with water droplets, oil, or welding spatter.
7. Install a silencer into port 3 (R) to prevent the ingress of dust if there is a lot of dust in the atmosphere.

If dust enters the valve via port 3 (R) , it may cause air leakage.

Maintenance

Warning

1. Perform maintenance procedures as shown in the instruction manual.

If handled improperly, malfunction or damage of machinery or equipment may occur.

2. Do not disassemble the product.

Improper handling will cause malfunction or breakage of the machinery or equipment.

3. When equipment is to be removed, first confirm that measures are in place to prevent dropping of driven objects and run-away of equipment, etc. Then cut the supply air pressure and electric power, and exhaust all compressed air from the system using its residual pressure release function.

When the equipment is to be started again after remounting or replacement, first confirm that measures are in place to prevent lurching of actuators and then confirm that equipment operates normally.

Caution

1. Once a lubricant is introduced, be sure to continue lubrication.

If it is discontinued, malfunction may result due to loss of the initial lubricant. Apply class 1 turbine oil (ISO VG32) as a lubricant. Use of other lubricants may cause malfunction.

Built-in Silencer (Option) Bronze Sintered Metal Element

Caution

Products made of bronze may contain uneven color due to the oxidization process of the atmosphere.

However, this oxidization process occurs in the limited range of less than 1 μ m of thickness and is so thin as to not affect the product characteristics.

The uneven color occurs depending on the storage duration before utilization (stock as a product, stock in customer)

* If this is a problem, please contact SMC so that SMC can pre-treat them with nickel plating.

Safety Instructions

These safety instructions are intended to prevent hazardous situations and/or equipment damage. These instructions indicate the level of potential hazard with the labels of “**Caution**,” “**Warning**” or “**Danger**.” They are all important notes for safety and must be followed in addition to International Standards (ISO/IEC)^{*1}, and other safety regulations.

 **Caution:** **Caution** indicates a hazard with a low level of risk which, if not avoided, could result in minor or moderate injury.

 **Warning:** **Warning** indicates a hazard with a medium level of risk which, if not avoided, could result in death or serious injury.

 **Danger:** **Danger** indicates a hazard with a high level of risk which, if not avoided, will result in death or serious injury.

- *1) ISO 4414: Pneumatic fluid power – General rules relating to systems.
ISO 4413: Hydraulic fluid power – General rules relating to systems.
IEC 60204-1: Safety of machinery – Electrical equipment of machines.
(Part 1: General requirements)
ISO 10218-1: Manipulating industrial robots – Safety.
etc.

Warning

1. The compatibility of the product is the responsibility of the person who designs the equipment or decides its specifications.

Since the product specified here is used under various operating conditions, its compatibility with specific equipment must be decided by the person who designs the equipment or decides its specifications based on necessary analysis and test results. The expected performance and safety assurance of the equipment will be the responsibility of the person who has determined its compatibility with the product. This person should also continuously review all specifications of the product referring to its latest catalog information, with a view to giving due consideration to any possibility of equipment failure when configuring the equipment.

2. Only personnel with appropriate training should operate machinery and equipment.

The product specified here may become unsafe if handled incorrectly. The assembly, operation and maintenance of machines or equipment including our products must be performed by an operator who is appropriately trained and experienced.

3. Do not service or attempt to remove product and machinery/equipment until safety is confirmed.

1. The inspection and maintenance of machinery/equipment should only be performed after measures to prevent falling or runaway of the driven objects have been confirmed.
2. When the product is to be removed, confirm that the safety measures as mentioned above are implemented and the power from any appropriate source is cut, and read and understand the specific product precautions of all relevant products carefully.
3. Before machinery/equipment is restarted, take measures to prevent unexpected operation and malfunction.

4. Contact SMC beforehand and take special consideration of safety measures if the product is to be used in any of the following conditions.

1. Conditions and environments outside of the given specifications, or use outdoors or in a place exposed to direct sunlight.
2. Installation on equipment in conjunction with atomic energy, railways, air navigation, space, shipping, vehicles, military, medical treatment, combustion and recreation, or equipment in contact with food and beverages, emergency stop circuits, clutch and brake circuits in press applications, safety equipment or other applications unsuitable for the standard specifications described in the product catalog.
3. An application which could have negative effects on people, property, or animals requiring special safety analysis.
4. Use in an interlock circuit, which requires the provision of double interlock for possible failure by using a mechanical protective function, and periodical checks to confirm proper operation.

Caution

1. The product is provided for use in manufacturing industries.

The product herein described is basically provided for peaceful use in manufacturing industries.

If considering using the product in other industries, consult SMC beforehand and exchange specifications or a contract if necessary.

If anything is unclear, contact your nearest sales branch.

Limited warranty and Disclaimer/ Compliance Requirements

The product used is subject to the following “Limited warranty and Disclaimer” and “Compliance Requirements”.

Read and accept them before using the product.

Limited warranty and Disclaimer

1. The warranty period of the product is 1 year in service or 1.5 years after the product is delivered, whichever is first.*2)

Also, the product may have specified durability, running distance or replacement parts. Please consult your nearest sales branch.

2. For any failure or damage reported within the warranty period which is clearly our responsibility, a replacement product or necessary parts will be provided.

This limited warranty applies only to our product independently, and not to any other damage incurred due to the failure of the product.

3. Prior to using SMC products, please read and understand the warranty terms and disclaimers noted in the specified catalog for the particular products.

*2) **Vacuum pads are excluded from this 1 year warranty.**

A vacuum pad is a consumable part, so it is warranted for a year after it is delivered.

Also, even within the warranty period, the wear of a product due to the use of the vacuum pad or failure due to the deterioration of rubber material are not covered by the limited warranty.

Compliance Requirements

1. The use of SMC products with production equipment for the manufacture of weapons of mass destruction (WMD) or any other weapon is strictly prohibited.

2. The exports of SMC products or technology from one country to another are governed by the relevant security laws and regulations of the countries involved in the transaction. Prior to the shipment of a SMC product to another country, assure that all local rules governing that export are known and followed.

 **Safety Instructions** Be sure to read “Handling Precautions for SMC Products” (M-E03-3) before using.



SMC Corporation of America
10100 SMC Blvd., Noblesville, IN 46060

www.smcusa.com

SMC Pneumatics (Canada) Ltd.
www.smc Pneumatics.ca

(800) SMC-SMC1 (762-7621)

e-mail: sales@smcusa.com

For International inquiries: www.smcworld.com