

# Process Valve

## VNB Series

### 2 Port Valve For Flow Control

#### A wide variety of applicable fluids

Proper selection with body and sealing materials permits application with a wide variety of fluids such as air, water, oil, gas and vacuum.

#### Cylinder actuation by external pilot air

#### Wide variations

N.C., N.O., C.O., types are available. Screw-in type (6A to 50A) and the flange (32F to 50F) are standardized.

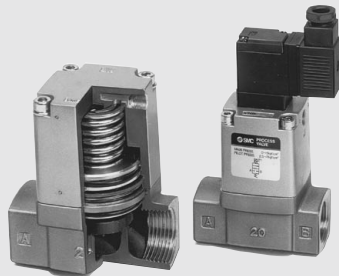

#### Selection Procedure

### 1 Applicable fluids

- Refer to "Table (1)" to check that the desired fluid is applicable.
- Select the body and sealing materials, depending on the fluid.

### 2 Flow rate characteristics (Air, Water)

- To find the flow rate of air or water, refer to the table of flow rate characteristics on page 10 to 16. Use the flow rate calculation equation to find the exact answer. Although the flow rate is the same, the operating pressure differs according to the valve size. Therefore, select the proper valve size from applicable valves.
- Refer to "Table (2)" to select the port size of the threaded type (6A to 50A) and flanges (32F to 50F).

### 3 Construction

- Select the air operated or external pilot solenoid types. Valves come in N.C. (normally closed), N.O. (normally open), C.O. (double acting), and N.C. 1 MPa (normally closed) types. Select the proper one according to the operating conditions.

### 4 Power voltage and electrical entry (External pilot solenoid)

- Select the AC/DC power source and choose the electrical entry according to "Table (3)".

**Table (1) Applicable Fluids Check List**

Wetted part Wetted part Seal material	Copper alloy: Standard			Aluminum: L			Stainless steel: S		
	NBR : A	FKM : B	EPR : C	NBR : A	FKM : B	EPR : C	NBR : A	FKM : B	EPR : C
Fluid									
Air (Standard, Dry)	●	●	●	●	●	●	●	●	●
Low vacuum (Up to -101 kPa)	●	●	●	●	●	●	●	●	●
Carbon dioxide (CO <sub>2</sub> , 0.7 MPa or less)	●	●	●	●	●	●	●	●	●
Carbon dioxide (CO <sub>2</sub> , 0.7 to 1 MPa)	●	●	●	●	●	●	●	●	●
Nitrogen gas (N <sub>2</sub> )	●	●	●	●	●	●	●	●	●
Argon	●	●	●	●	●	●	●	●	●
Helium	●	●	●	●	●	●	●	●	●
Water (standard, up to 60°C)	●	●	●	●	●	●	●	●	●
Water (up to 99°C air operated type only)	●	●	●	●	●	●	●	●	●
Turbine oil	●	●	●	●	●	●	●	●	●
Spindle oil	●	●	●	●	●	●	●	●	●
Fuel oil Class 3 (C fuel oil)	●	●	●	●	●	●	●	●	●
Silicone oil	●	●	●	●	●	●	●	●	●
Naphtha	●	●	●	●	●	●	●	●	●
Ethylene glycol (up to 80°C)	●	●	●	●	●	●	●	●	●
Boiler water	●	●	●	●	●	●	●	●	●

#### ⚠ Caution

Note 1) When fluid permits application of multiple body and sealing materials, select the most suitable one according to the ambient environment (FKM or EPR seal material for high temperature) and other conditions (corrosion resistance and viscosity), etc.

Note 2) Test fluids to see if it will wash out cleaning liquid such as grease.

**Table (2) Combinations between Valve Size and Port Size**

Valve size	Port size											
	6A	8A	10A	15A	20A	25A	32A	32F	40A	40F	50A	50F
1	●	●	●									
2			●									
3				●								
4					●							
5						●						
6							●					
7											●	

**Table (3) Combinations between Electrical Entry and Light/Surge Voltage Suppressor**

Valve size	Electrical entry				Light/Surge voltage suppressor		Manual override
	G	E	T	D	S	Z	
1, 2, 3, 4	●	●	●	●	●	●	●
5, 6, 7	●	●	●	●	(Only "G")	(Except "G")	●
					(Only "G")	(Only "D")	

VNA  
VNB  
SGC  
SGH  
VNC  
VNH  
VND  
VCC  
TQ



# Process Valve: 2 Port Valve For Flow Control **VNB Series**

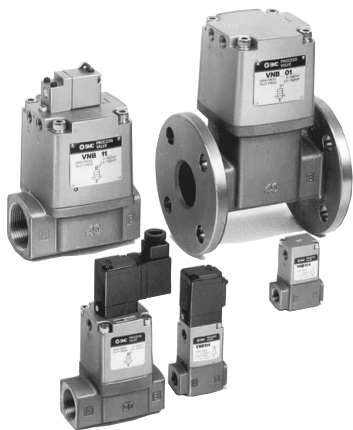

## Model

Model	Port size Rc	Orifice dia. ø (mm)	Flow rate characteristics						Weight (kg)	
			Measured by air			Measured by water			Air operated	External pilot solenoid
			C [dm <sup>3</sup> /(bar·sec)]	b	Cv	Kv	Conversion Cv			
VNB1□□□-6A	1/8	7	3.3	0.29	0.80	0.9	1.0	0.3	0.4	
VNB1□□□-8A	1/4		4.6	0.17	1.0	1.0	1.2			
VNB1□□□-10A	3/8		4.7	0.18	1.1	1.1	1.3			
VNB2□□□-10A	1/2	11	9.6	0.40	2.6	2.5	2.9	0.6	0.7	
VNB2□□□-15A		15	17	0.32	4.0	3.9	4.5			
VNB2□□□-20A		11	9.6	0.40	2.6	2.7	3.1			
VNB3□□□-20A	3/4	15	19	0.24	4.8	5.0	5.8	0.9	1.0	
VNB3□□□-20A	14	18	0.42	5.4	5.0	5.8				
VNB3□□□-20A	20	35	0.13	7.4	9.6	11				

Model	Port size Rc	Flange <sup>Note 1</sup>	Orifice dia. ø (mm)	Flow rate characteristics				Weight (kg)	
				Measured by air		Measured by water		Air operated	External pilot solenoid
				Effective area (mm <sup>2</sup> )	Kv	Conversion Cv			
VNB4□□□-25A	1	—	16	130	6.1	7.0	1.4	1.5	
VNB4□□□-25A			25	220	10.4	12			
VNB5□□□-32A			22	210	9.8	11			
VNB5□□□-32A	1 1/4	—	32	320	15.6	18	2.5	2.6	
VNB5□□□-32F			22	210	9.8	11			
VNB5□□□-32F			32	320	15.6	18			
VNB6□□□-40A	1 1/2	—	28	330	16.4	19	4.1	4.2	
VNB6□□□-40A			40	500	24.2	28			
VNB6□□□-40F			28	330	16.4	19			
VNB6□□□-40F	—	40	40	500	24.2	28	7.7	7.8	
VNB7□□□-50A			33	520	25.1	29			
VNB7□□□-50A			50	770	37.2	43			
VNB7□□□-50F	2	—	33	520	25.1	29	6.3	6.4	
VNB7□□□-50F			50	770	37.2	43			
VNB7□□□-50F	—	50	33	520	25.1	29	11.4	11.5	
VNB7□□□-50F			50	770	37.2	43			

Note) The flange should be JIS B 2210 10K (ordinary type) or its equivalent.

## Symbol

Type	Valve type	N.C.	N.O.	C.O.
		Normally closed	Normally open	Double acting
Air operated		VNB□0□	VNB□02	VNB□03
		VNB□1□	VNB□12	
External pilot solenoid		VNB□1□	VNB□12	

Note) Flow direction should be from port 1 (A) to port 2 (B) for vacuum applications.

## Option Specifications

### Vacuum pilot valve VNB□□□□V

(Valve size 2 to 7)

It is used when the valve is to be operated by the main vacuum in the absence of pressurized air.

## Specifications (Vacuum pilot type)

Fluid	Vacuum
Operating pressure range	-101 kPa to Atmospheric pressure
Pilot pressure range	-101 to -47.9 kPa

## Symbol (Vacuum pilot type)

Type	Valve type	N.C.	N.O.
		Normally closed	Normally open
Air operated		VNB□01□V	VNB□02□V
		VNB□11□V	VNB□12□V
External pilot solenoid		VNB□11□V	VNB□12□V

## Specifications

Fluid	Water/Oil/Air/Vacuum, etc.	
Fluid temperature	VNB□□□A, VNB□□□E	-5 to 60°C <sup>Note 1)</sup>
	VNB□□□E	-5 to 99°C <sup>Note 1)</sup>
Ambient temperature	-5 to 50°C <sup>Note 1)</sup> (Air operated type: 60°C)	
Proof pressure	1.5 MPa	
Applicable pressure range	VNB□□□1□	Low vacuum to 0.5 MPa
	VNB□□□3□	Low vacuum to 1 MPa
	VNB□□□4□	0.25 to 0.7 MPa
External pilot air	Pressure: VNB□□□3□	0.1 + 0.25 x (Operating pressure) to 0.25 + 0.25 x (Operating pressure) MPa <sup>Note 3)</sup> Refer to "Graph (1)" on page 568.
	Lubrication	Not required (Use turbine oil Class 1 ISO VG32, if lubricated. <sup>Note 2)</sup> )
	Temperature	-5 to 50°C (Air operated type: 60°C)
Mounting orientation	Unrestricted <sup>Note 5)</sup>	

Note 1) No freezing

Note 2) Lubrication is not allowed in the case of seal material EPDM.

Note 3) Set the operating pressure range from 0.125 MPa to 0.275 MPa for low vacuum.

Note 4) The pressure differential between Port 1 (A) and 2 (B) must not exceed the maximum operating pressure.

Note 5) For external pilot solenoid, it is recommended that the pilot solenoid valve be oriented either vertically upward or horizontally.

## Pilot Solenoid Valve Specifications

Port size	6A to 25A	32A to 50A
Pilot solenoid valve <sup>Note 1)</sup>	SF4-□□□-23 SF4-□□-23-Q	VO307-□□□□ VO307-□□-1-Q
Electrical entry	Grommet, Grommet terminal Conduit terminal DIN terminal	Grommet, DIN terminal
Coil rated voltage (V)	AC (50/60 Hz) DC	100 V, 200 V, Other voltage (Semi-standard) 24 V, Other voltage (Semi-standard)
Allowable voltage fluctuation	-15% to +10% of rated voltage	
Temperature rise	35°C or less (When rated voltage is applied.) 50°C or less (When rated voltage is applied.)	
Apparent power	AC	Inrush Holding
	DC	5.6 VA (50 Hz), 5.0 VA (60 Hz) 3.4 VA (50 Hz), 2.3 VA (60 Hz)
Power consumption	DC	12.7 VA (50 Hz), 10.7 VA (60 Hz) 7.6 VA (50 Hz), 5.4 VA (60 Hz)
Manual override	Non-locking push type Other (Semi-standard)	
	Non-locking push type	

Note 1) For "How to Order" pilot solenoid valves, refer to page 570.

Note 2) Vacuum pilot type pilot solenoid valves will become VO301V-□□□□.

Note 3) Vacuum pilot type CE-compliant pilot solenoid valve will become VO307V-□□□□.

# VNB Series

## How to Order Pilot Solenoid Valves

### Valve size 1/2/3/4

SF4 - **5** **D** - 23 - **Q**

**Coil rated voltage**

1	100 VAC 50/60 Hz
2	200 VAC 50/60 Hz
3 <small>Note 1)</small>	110 VAC 50/60 Hz
4 <small>Note 1)</small>	220 VAC 50/60 Hz
5	24 VDC
6 <small>Note 1)</small>	12 VDC
7 <small>Note 1)</small>	240 VAC 50/60 Hz

Note 1) Semi-standard  
Note 2) For other rated voltages, please consult with SMC.

**CE-compliant**

Nil	—
Q	CE-compliant

\* Electrical entry: D or DZ only

**Manual override**

Nil	Non-locking push type
A*	Non-locking push type A (projecting)
B*	Slotted locking type B (tool required)

\* Semi-standard

**Electrical entry/With indicator light/surge voltage suppressor**

	CE-compliant	
G	Grommet	—
GS	Grommet with surge voltage suppressor	—
E	Grommet terminal	—
EZ	Grommet terminal with light/surge voltage suppressor	—
T	Conduit terminal	—
TZ	Conduit terminal with light/surge voltage suppressor	—
D	DIN terminal	●
DZ	DIN terminal with light/surge voltage suppressor	●

### Valve size 5/6/7 and vacuum pilot type

VO307 - **5** **D** 1 - **Q**

**Body option**

Nil	Standard
V	Vacuum pilot

**Coil rated voltage**

1	100 VAC 50/60 Hz
2	200 VAC 50/60 Hz
3 <small>Note 1)</small>	110 VAC 50/60 Hz
4 <small>Note 1)</small>	220 VAC 50/60 Hz
5	24 VDC
6 <small>Note 1)</small>	12 VDC
7 <small>Note 1)</small>	240 VAC 50/60 Hz

Note 1) Semi-standard  
Note 2) For other rated voltages, please consult with SMC.

**CE-compliant**

Nil	—
Q	CE-compliant

\* Electrical entry: D or DZ only

**Electrical entry**

	CE-compliant	
G	Grommet	—
GS	Grommet with surge voltage suppressor	—
D	DIN terminal	●
DZ	DIN terminal with light/surge voltage suppressor	●

### Accessory

Function plate for VO307 (D sealing, with thread): DXT152-14-5A

## Construction

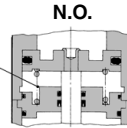
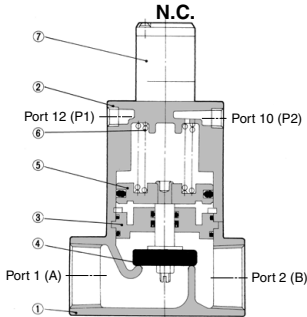

\* C.O. type does not have a return spring ⑥.

## Working Principle (Vacuum pilot type is excluded)

### VNB□0□□, □1□ (N.C.)

When the pilot solenoid valve ⑦ is not energized (or when air is exhausted from the port P1 of the air operated type), the valve element ④ linked to the piston ⑤ is closed by the return spring ⑥.

### • When valve opens

When the pilot solenoid valve is energized (or when pressurized air enters through the port P1 of the air operated type), the pilot air that has entered under the piston moves upward to open the valve element.

### • When valve closes:

When the power to the pilot solenoid valve is turned off (or when fluid is exhausted from the port P1 of the air operated type), the pilot air under the piston is exhausted, and the return spring closes the valve element.

### VNB□02□, □12□ (N.O.)

In contrast with the N.C., when the power to the pilot solenoid valve is turned off (or when air is exhausted from the port P2 of the air operated type), the valve is held open by the return spring. When the pilot solenoid valve is energized (or when pressurized air enters through the port P2 of the air operated type), the valve element closes.

### VNB□03□ (C.O.)

The valve element for the C.O. type, which has no return spring, is in an arbitrary position when air is exhausted through the ports P1 and P2. When pressurized air enters the port P1 (exhaust from the port P2), the valve element opens, and it closes when pressurized air enters the port P2 (exhaust from the port P1).

## Component Parts

No.	Description	Material	Note
1	Body	Bronze <small>Note 2)</small>	Clear coated
2	Cover assembly	Aluminum alloy	Platinum silver painted
3 <small>Note 1)</small>	Plate assembly	Brass <small>Note 2)</small>	Seal material (NBR, FKM, EPR)
4 <small>Note 1)</small>	Valve element	Stainless steel or brass <small>Note 2)</small>	Seal material (NBR, FKM, EPR)
5	Piston assembly	Aluminum alloy	—
6	Return spring	Piano wire	—
7	Pilot solenoid valve	—	—

Note 1) Parts ③ and ④ are for selection of valve composition.  
Note 2) The body option "S" is stainless steel, and "L" is aluminum.

## Replacement Parts

No.	Description	Part no.										
		VNB1□□□ -6A, 8A, 10A	VNB2□□□ -10A, 15A	VNB3□□□ -20A	VNB4□□□ -25A	VNB5□□□ -32A, 32F	VNB5□4□ -32A, 32F	VNB6□□□ -40A, 40F	VNB6□4□ -40A, -40F	VNB7□□□ -50A, 50F	VNB7□4□ -50A, 50F	
3 <small>Note 1)</small>	Plate assembly	Seal material	NBR	VN2-A3BA	VN3-A3BA	VN4-A3BA	VN5-A3BA	VN5-A3BA	VN6-A3BA	VN6-A3BA	VN7-A3BA	VN7-A3BA
			FKM	VN2-A3BB	VN3-A3BB	VN4-A3BB	VN5-A3BB	VN5-A3BB	VN6-A3BB	VN6-A3BB	VN7-A3BB	VN7-A3BB
4 <small>Note 1)</small>	Valve element <small>(S2 P to S9 P come in valve element assembly)</small>	Seal material	NBR	VN2-A3BC	VN3-A3BC	VN4-A3BC	VN5-A3BC	VN5-A3BC	VN6-A3BC	VN6-A3BC	VN7-A3BC	VN7-A3BC
			FKM	VN2-4BA	VN3-4BA	VN4-4BA	VN5-4BA	VN5-A4BA-3	VN6-4BA	VN6-A4BA-3	VN7-4BA	VN7-A4BA-3
7	Pilot solenoid valve	EPR	NBR	VN2-4BB	VN3-4BB	VN4-4BB	VN5-A4BB	VN5-A4BB-3	VN6-A4BB	VN6-A4BB-3	VN7-A4BB	VN7-A4BB-3
			FKM	VN2-4BC	VN3-4BC	VN4-4BC	VN5-A4BC	VN5-A4BC-3	VN6-A4BC	VN6-A4BC-3	VN7-A4BC	VN7-A4BC-3

Note 1) In the case of body options "S" and "L", the materials of the part nos. ③ and ④ are as follows: (Example): VN1-A3B□

However all brackets of valve element VN1 to 4 are made of stainless steel. (No need to add options "S" and "L"). L: Aluminum, S: Stainless steel

Note 2) Please request a factory repair.

**Port size: 6A, 8A, 10A**

**Standard**

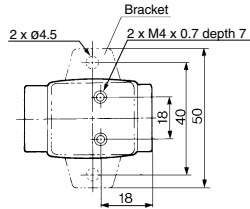
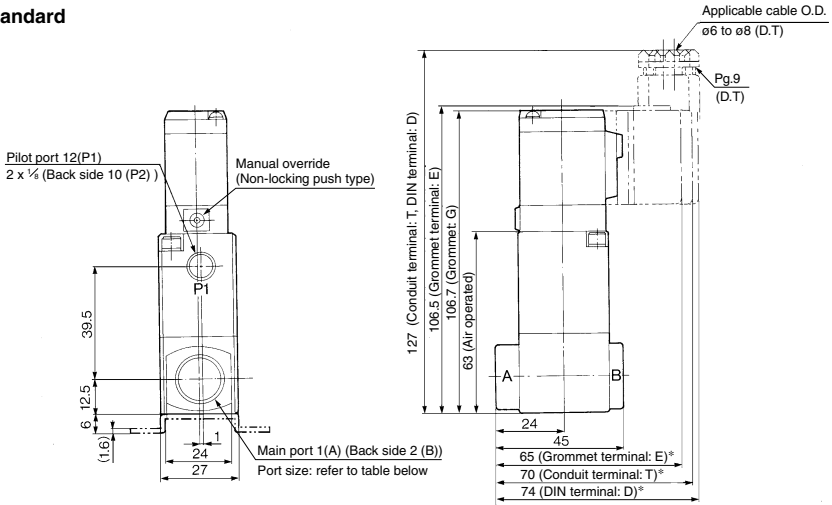

\* In the case of "EZ" or "TZ", the length is longer by 10 mm.  
For "DZ", the length is longer by 17 mm.

Model	Main port 1(A), 2(B)
VNB1□□□-6A	1/8
VNB1□□□-8A	1/4
VNB1□□□-10A	3/8

VNA

VNB

SGC

SGH

VNC

VNH

VND

VCC

TQ

# VNB Series

## Port size: 10A, 15A, 20A, 25A

### Standard

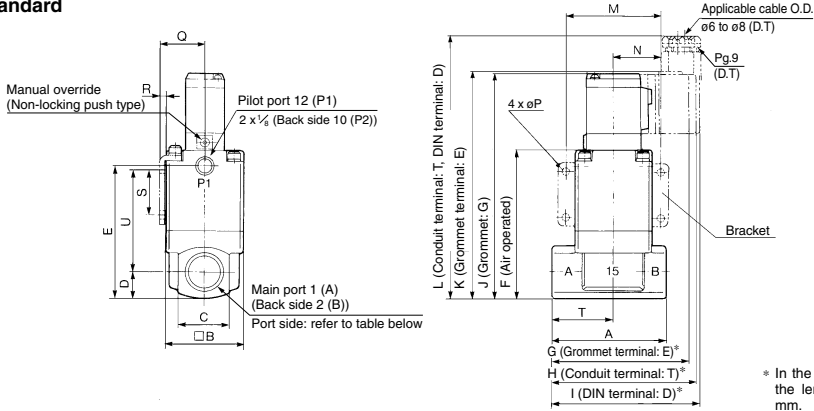

\* In the case of "EZ" or "TZ", the length is longer by 10 mm.  
For "DZ", the length is longer by 17 mm.

Model	Main port 1(A), 2(B)	A	B	C	D	E	F	G	H	I	J	K	L	M	N	P	Q	R	S	T	U
VNB2□□□-10A	3/8	63	42	28	14	72.5	80.5	75	80	84.5	124	125.5	144.5	52	26	4.5	24.3	2.3	25	34	55
VNB2□□□-15A	1/2	80	50	35	17.5	84	92	84	89	93.5	135.5	137	156	62	31	5.5	28.3	2.3	30	43	60.5
VNB3□□□-20A	3/4	80	50	35	17.5	84	92	84	89	93.5	135.5	137	156	62	31	5.5	28.3	2.3	30	43	60.5
VNB4□□□-25A	1	90	60	44	22	100	108	90	95	99.5	151.5	153	172	72	36	6.5	33.3	2.3	35	49	73

## Port size: 10A, 15A, 20A, 25A

### Vacuum pilot

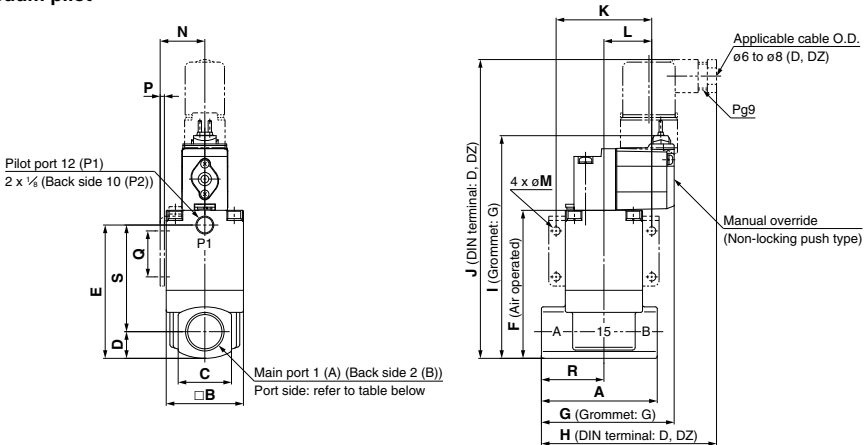

Model	Main port 1(A), 2(B)	A	B	C	D	E	F	G	H	I	J	K	L	M	N	P	Q	R	S
VNB2□□□V-10A	3/8	63	42	28	14	72.5	80.5	72.2	95.3	121.1	162.5	52	26	4.5	24.3	2.3	25	34	55
VNB2□□□V-15A	1/2	80	50	35	17.5	84	92	77.2	100.3	132.6	174	62	31	5.5	28.3	2.3	30	43	60.5
VNB3□□□V-20A	3/4	80	50	35	17.5	84	92	77.2	100.3	132.6	174	62	31	5.5	28.3	2.3	30	43	60.5
VNB4□□□V-25A	1	90	60	44	22	100	108	78.2	101.3	148.6	190	72	36	6.5	33.3	2.3	35	49	73

**Port size: 32A, 40A, 50A**

**Standard/Vacuum pilot**

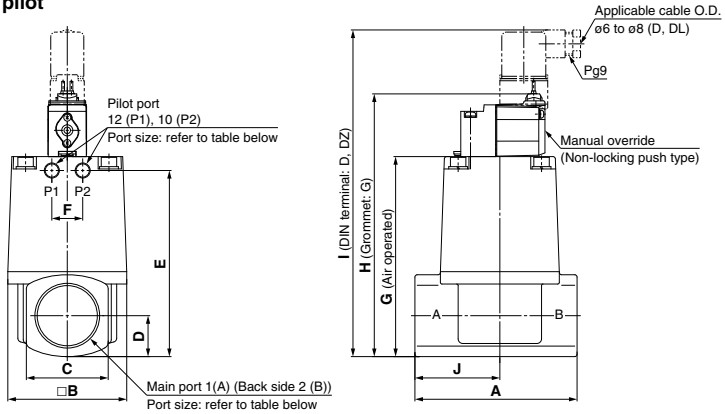

Model	Main port 1(A), 2(B)	Pilot port 12(P1), 10(P2)	A	B	C	D	E	F	G	H	I	J
VNB5□□□□-32A	1 1/4	1/8	105	77	53	26.5	120.5	20	129.5	170.1	211.5	55
VNB6□□□□-40A	1 1/2	1/4	120	96	60	30	137	24	147	187.6	229	63
VNB7□□□□-50A	2	1/4	140	113	74	37	160	24	170	210.6	252	74

**Port size: Flange: 32F, 40F, 50F**

**Standard/Vacuum pilot**

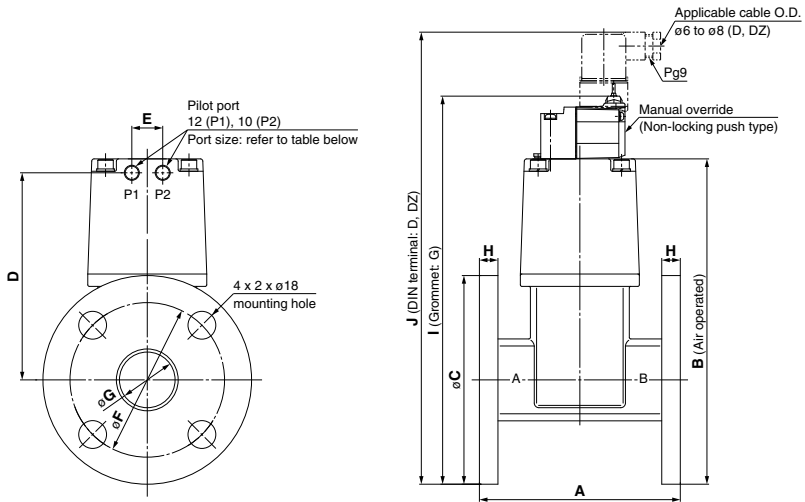

Model	Applicable flange 1(A), 2(B)	Pilot port 12(P1), 10(P2)	A	B	C	D	E	F	G	H	I	J
VNB5□□□□-32F	32	1/8	130	210.5	135	134	20	100	36	12	251.1	292.5
VNB6□□□□-40F	40	1/4	150	226	140	146	24	105	42	12	266.6	308
VNB7□□□□-50F	50	1/4	180	250	155	162.5	24	120	54	14	290.6	332

- VNA
- VNB
- SGC
- SGH
- VNC
- VNH
- VND
- VCC
- TQ



## VNB Series

# Specific Product Precautions

Be sure to read this before handling the products.

Refer to back page 50 for Safety Instructions and pages 17 to 19 for 2 Port Solenoid Valve for Fluid Control Precautions.

### Design

#### Warning

##### Extended periods of continuous energization

If a valve is continuously energized for long periods, heat generation of the coil may result in reduced performance and shorter service life. This may also have an adverse effect on the peripheral equipment in proximity. Should a valve be continuously energized for long periods, or its daily energized state exceeds its non energized state, please use an energy saving type valve with DC specifications. Additionally, when using with AC, energizing for long periods of time continuously, select the air-operated valve and use the continuous duty type of the VT307 for a pilot valve.

### Fluid Quality

#### Warning

If a fluid that contains foreign matter is used, foreign matter may enter the rod sliding part, causing malfunction or seal failure. If seal failure occurs in the rod sliding part, the fluid backflows in the pilot air piping and may enter units in the circuit connected to the pilot air piping, causing adverse effect. So, perform the maintenance work periodically or take preventive measures appropriately.

### Mounting

#### Warning

- Do not apply external force to the coil section.**  
When tightening is performed, apply a wrench or other tool to the outside of the piping connection parts.
- Do not warm the coil assembly with a heat insulator, etc.**  
Use tape, heaters, etc., for freeze prevention on the piping and body only. They can cause the coil to burn out.
- Avoid sources of vibration, or adjust the arm from the body to the minimum length so that resonance will not occur.**

### Piping

#### Caution

When high temperature fluids are used, use fittings and tubing with heat resistant features. (Self-align fittings, PTFE tubing, Copper tubing, etc.)

### Wiring

#### Caution

- Applied voltage**  
When electric power is connected to a solenoid valve, be careful to apply the proper voltage. Improper voltage may cause malfunction or coil damage.
- Confirm the connections.**  
After completing the wiring, confirm that the connections are correct.

### External Pilot

#### Warning

##### Pilot port piping

12 (P1) and 10 (P2) piping should be as follows according to the model.

##### Standard

Port	VNB□0 $\frac{1}{4}$ □	VNB□02□	VNB□03□	VNB□1 $\frac{1}{4}$ □
12 (P1)	External pilot	Bleed port	External pilot (*)	External pilot
10 (P2)	Bleed port	External pilot	External pilot (*)	Pilot exhaust

(\*) If the pilot air is not supplied, the valve position will not be held. Pressurize Port 12 (P1) or Port 10 (P2) when using the product.

##### Vacuum pilot

Port	VNB□01V□	VNB□02V□	VNB□1 $\frac{1}{2}$ V□
12 (P1)	Bleed port	External pilot	External pilot
10 (P2)	External pilot	Bleed port	Pilot exhaust

Installing a silencer to the exhaust port and the bleed port is recommended for noise reduction and for dust entry prevention.

### Mounting Direction of Pilot Solenoid Valve

#### Warning

With external pilot solenoids, the pilot solenoid valves are not splash proof specifications, and so care must be taken not to get fluid on oneself such as when performing maintenance.

#### Caution

##### Direction of mounting

When replacing a valve, if an external pilot solenoid valve is mounted in the wrong direction, it may malfunction or leak air.

### Vacuum Pilot

#### Caution

When using the VNB□□V. vacuum pilot, maintain the specified pilot pressure by providing a tank with an appropriate capacity or by acquiring the pilot pressure from an area near the vacuum pump.

