

Stainless Steel High Vacuum Angle/In-line Valve

XM, XY Series



Angle type/
XM Series

In-line type
XY Series

- **Body material: SCS13**
(conforms to Stainless steel 304)
 - A precision casting, unified composition prevents accumulation of gas.
 - The XM series is interchangeable with the XL series, aluminum high vacuum angle valve.
- Lightweight & compact**

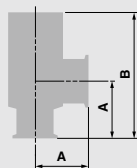

XMA series with KF (NW) flange

Model	A* (mm)	B (mm)	Weight (kg)	Conductance (L/s)
XMA-16	40	103	0.33	5
XMA-25	50	113	0.61	14
XMA-40	65	158	1.40	45
XMA-50	70	170	2.00	80
XMA-63	88	196	3.60	160
XMA-80	90	235	6.20	200

*: Common to all series.

Piping example

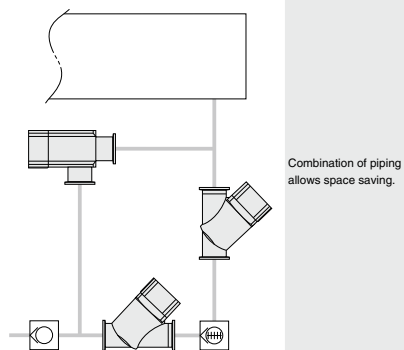

XLA

XL□

XL□Q

XM□

XY□

D-□









XSA

XVD

XGT

CYV

Series Variations

Application	Shaft seal system	Models		Valve type	Operating pressure Pa	Flange size						Options				
		Angle type	In-line type			16	25	40	50	63	80	Switch	Indicator	high temp. specification		
Air operated																
Particulate free	Bellows seal	XMA 	XYA 	Single acting (N.C.)	Atmospheric pressure to 1 x 10 ⁶	Note										
		XMC 	XYC 	Double acting		Note										
Reduces particulates Eliminates pump overload	Bellows, O-ring seal	XMD 	XYD 	Single acting (N.C.)									Standard			
Manual																
Particulate free	Bellows seal	XMH 	XYH 	Manual	Atmospheric pressure to 1 x 10 ⁶	Note							Standard	Standard		

Please contact SMC for with solenoid valve.

Note) The in-line valve is not available in flange size 16.

Bellows seal, Single acting: XMA, XYA
Bellows seal, Double acting: XMC, XYC

- Bellows type is particulate free and completely cleaned.
- Pressure balancing mechanism.

2 stage control, Single acting: XMD, XYD

- Initial stage exhaust valve and main exhaust valve are combined. (flow rate 2-step control valve)
- Designed with a compact system and reduced piping.
- Prevents particulate turbulence inside the chamber during exhaustion.
- Prevents pumps from running while overloaded.
- Initial exhaust valve flow is adjustable and adjustment can be locked.

Bellows seal, Manual operation: XMH, XYH

- Bellows type is particulate free and completely cleaned.
- Pressure balance mechanism allows unrestricted exhaust direction.
- Low actuation torque (0.5 N-m or less).
- Spring provides standard sealing load.
- Handle height is the same when valve is open or closed.
- Indicator to confirm opening and closing of valve is standard equipment.

Stainless steel High Vacuum Angle/In-line Valve Normally Closed/Bellows Seal **XMA, XYA Series**



How to Order

Angle type

XMA - 16 - [] - M9N A - []

In-line type

XYA - 25 - [] - M9N A - []

Note) The XMAV and XYAV series with solenoid valve are also available. Please contact SMC for details.



① Flange size

Size	XMA	XYA
16	●	—
25	●	●
40	●	●
50	●	●
63	●	●
80	●	●

② Flange type

XMA

Symbol	Type	Applicable flange size
NII	KF (NW)	16, 25, 40, 50, 63, 80
D	K (DN)	63, 80
C	CF	16 (034), 40 (070), 63 (114)

XYA

NII	KF (NW)	25, 40, 50, 63, 80
D	K (DN)	63, 80

③ Indicator/Pilot port direction

XMA

Symbol	Indicator	Pilot port direction
NII	Without indicator	Flange side
A		Flange side
F	With indicator	Left flange surface
G		Rear flange surface
J		Right flange surface
K		Left flange surface
L	Without indicator	Rear flange surface
M		Right flange surface

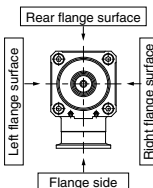

XYA

Symbol	Indicator	Pilot port direction
NII	Without indicator	Rear flange side
A		Rear flange side
F	With indicator	Left flange surface
J		Right flange surface
K		Left flange surface
M	Without indicator	Right flange surface

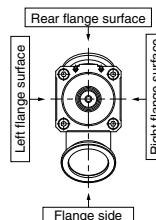

④ Temperature specifications

Symbol	Temperature range
NII	5 to 60°C
H0	5 to 150°C

⑥ Number of auto switches/Detecting position

Symbol	Quantity	Detecting position
NII	Without auto switch	—
A	2 pcs.	Valve open/closed
B	1 pc.	Valve open
C	1 pc.	Valve closed

⑤ Auto switch type

Symbol	Auto switch	Remarks
NII	—	Without auto switch (without built-in magnet)
M9N(M)(L)(Z)	D-M9N(M)(L)(Z)	Solid state auto switch
M9P(M)(L)(Z)	D-M9P(M)(L)(Z)	
M9B(M)(L)(Z)	D-M9B(M)(L)(Z)	
A90(L)	D-A90(L)	Reed auto switch
A93(M)(L)(Z)	D-A93(M)(L)(Z)	(Flange size 16 is not available.)
M9//	—	Without auto switch (with built-in magnet)

Auto switches are not applicable for high-temperature specifications (Temperature specification H0). Standard lead wire length is 0.5 m. Add "L" to the end of the part number when 3 m is desired, "M" when 1 m, and "Z" when 5 m.
Ex.) -M9NL

⑦ Seal material and its changed part

• Seal material

Symbol	Seal material	Compound No.
NII	FKM	1349-80*
N1	EPDM	2101-80*
P1	Barrel Perfluoro®	70W
Q1	Kalrez®	4079
R1	Chemraz®	SS592
R2		SS630
R3		SSE38
S1		VMQ
T1	FKM for Plasma	3310-75*
U1	ULTIC ARMOR®	UA4640

* Produced by Mitsubishi Cable Industries, Ltd.

Barrel Perfluoro® is a registered trademark of Matsumura Oil Co., Ltd.
Kalrez® is a registered trademark of E. I. du Pont de Nemours and Company or its affiliates.
Chemraz® is a registered trademark of Greene, Tweed & Co.
ULTIC ARMOR® is a registered trademark of Nippon Valqua Industries, Ltd.

• Part numbers indicating changed seal material and leakage

Symbol	Changed part (Note 2)	Leakage (Pa·m³/s or less) (Note 1)	
		Internal	External
NII	—	1.3×10^{-10} (FKM)	1.3×10^{-11} (FKM)
A	②, ③	1.3×10^{-8}	1.3×10^{-9}
B	②	1.3×10^{-8}	1.3×10^{-11} (FKM)
C	③	1.3×10^{-10} (FKM)	1.3×10^{-9}

Note 1) Values at ambient temperatures, excluding gas permeation.

Note 2) Refer to parts number of "Construction" on the page 482 for changed part. Number indicates parts number of "Construction" accordingly.

To order something else "NII" (standard), list the symbols starting with "X," followed by each symbol for "seal material" and then "changed parts" at last.

Ex.) XMA-16-M9NA-XN1A

XLA

XL□

XL□Q

XM□

XY□

D-□

XSA

XVD

XGT

CVV

XMA, XYA Series

Specifications

Model	XMA-16		XMA-25 XYA-25	XMA-40 XYA-40	XMA-50 XYA-50	XMA-63 XYA-63	XMA-80 XYA-80
Flange (valve) size	16, CF034		25	40, CF070	50	63, CF114	80
Valve type	Normally closed (Pressurize to open, spring seal)						
Fluid	Inactive gas under vacuum						
Operating temperature (°C)	5 to 60 (High temperature type: 5 to 150)						
Operating pressure (Pa)(abs)	1 x 10 ⁻⁶ up to atmospheric pressure						
Conductance (L/s) ^{Note 1)}	5		14	45	80	160	200
Leakage (Pa·m ³ /s)	Internal	1.3 x 10 ⁻¹⁰ {1 x 10 ⁻¹⁰ } at ambient temperature, excluding gas permeation (Standard material: FKM)					
	External	1.3 x 10 ⁻¹¹ {1 x 10 ⁻¹¹ } at ambient temperature, excluding gas permeation (Standard material: FKM)					
Operating time (s)	0.05		0.1	0.21	0.24	0.26	0.28
Flange type	KF (NW), CF		KF (NW)	KF (NW), CF	KF (NW)	KF (NW), K (DN), CF	KF (NW), K (DN)
Principle materials	Body: SCS13 (Conforms to Stainless steel 304) Bellows: Stainless steel 316L Bellows holder: Stainless steel 304. FKM (Standard seal material)						
Pilot pressure (MPa)(G)	0.4 to 0.7						
Pilot port size	M5			Rc 1/8			
Weight (kg) ^{Note 2)}	XMA	0.33 (0.37)	0.61	1.40 (1.76)	2.00	3.60 (4.96)	6.20
	XYA	—	0.66	1.42	2.40	4.30	7.70

Note 1) Conductance is the value for the molecular flow of an elbow having the same dimensions.

Note 2) Figures in () indicates the weight of CF (conflate) fittings.

Construction

XMA/Angle type

XYA/In-line type

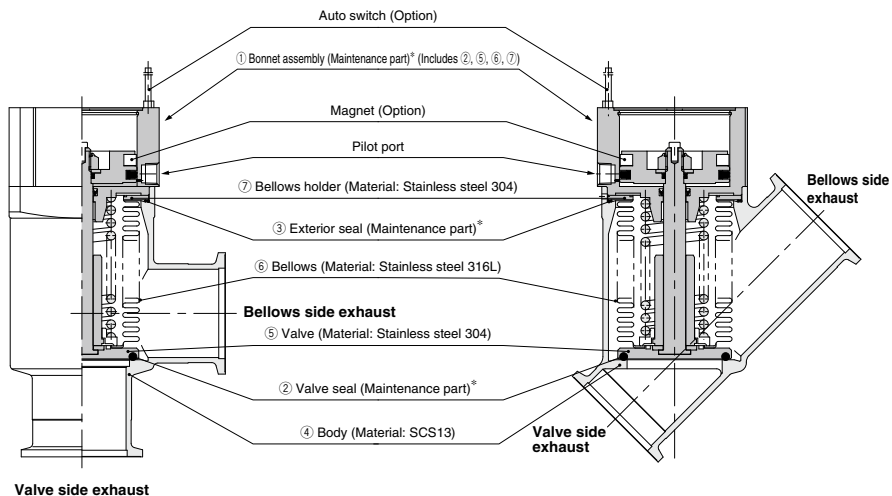

* Refer to page 497 for maintenance parts.

Stainless steel **XMA, XYA Series**

High Vacuum Angle/In-line Valve

Dimensions

XMA/Angle type

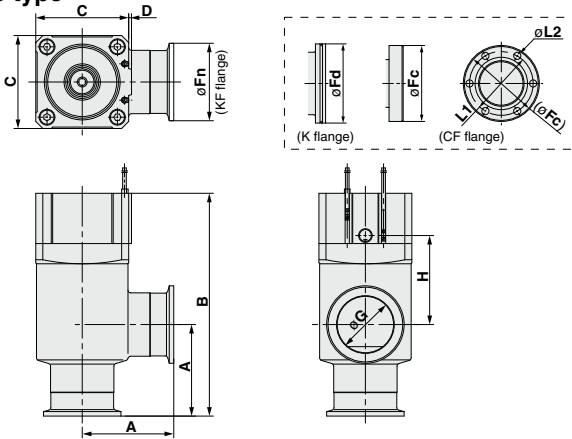

Model	A	B	C	D	Fn	Fd	Fc	G	H	P.C.D	L1	L2
XMA-16	40	103	38	1	30	—	34	17	40	P.C.D 27	6 x $\phi 4.4$	—
XMA-25	50	113	48	1	40	—	—	26	39	—	—	—
XMA-40	65	158	66	2	55	—	70	41	63	P.C.D 58.7	6 x $\phi 6.6$	—
XMA-50	70	170	79	2	75	—	—	52	68	—	—	—
XMA-63	88	196	100	3	87	95	114	70	69	P.C.D 92.1	8 x $\phi 8.4$	—
XMA-80	90	235	117	3	114	110	—	83	96	—	—	—

(mm)

XYA/In-line type

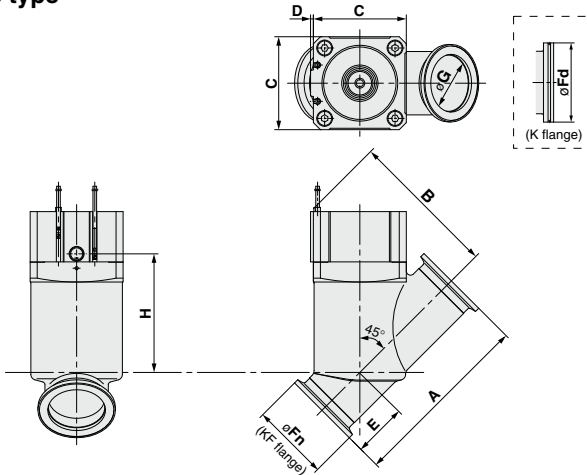

Model	A	B	C	D	E	Fn	Fd	G	H
XYA-25	100.2	79.5	48	1	23.5	40	—	26	64
XYA-40	130	106	66	2	38	55	—	41	84
XYA-50	178	119	79	2	53	75	—	52	95
XYA-63	209	149	100	3	61	87	95	70	118
XYA-80	268	178	117	3	80	114	110	83	142

(mm)

- XLA
- XL□
- XL□Q
- XMA□
- XY□
- D-□
- XSA
- XVD
- XGT
- CYV

Stainless steel High Vacuum Angle/In-line Valve Double Acting/Bellows Seal **XMC, XYC Series**

How to Order



Angle type

Flange size
16, 25, 40

XMC - 16 - M9N A

Flange size
50, 63, 80

XMC - 50 - 1 M9N A



In-line type

Flange size
25, 40

XYC - 25 - M9N A

Flange size
50, 63, 80

XYC - 50 - 1 M9N A

Note) The XMC and XYC series with solenoid valve are also available. Please contact SMC for details.

① Flange size

Size	XMC	XYC
16	●	—
25	●	●
40	●	●
50	●	●
63	●	●
80	●	●

③ Pilot port direction

XMC

Symbol	Pilot port direction
Nil	Flange side
K	Left flange surface
L	Rear flange surface
M	Right flange surface

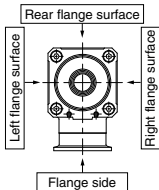

② Flange type

XMC

Symbol	Type	Applicable flange size
Nil	KF (NW)	16, 25, 40, 50, 63, 80
D	K (DN)	63, 80
C	CF	16 (034), 40 (070), 63 (114)

XYC

Nil	KF (NW)	25, 40, 50, 63, 80
D	K (DN)	63, 80

XYC

Symbol	Pilot port direction
Nil	Rear flange surface
K	Left flange surface
M	Right flange surface

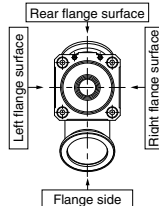

④ Temperature specifications

Symbol	Temperature range
Nil	5 to 60°C
H0	5 to 150°C

⑥ Number of auto switches/Detecting position

Symbol	Quantity	Detecting position
Nil	Without auto switch	—
A	2 pcs.	Valve open/closed
B	1 pc.	Valve open
C	1 pc.	Valve closed

⑤ Auto switch type

Symbol	Auto switch	Remarks
Nil	—	Without auto switch (without built-in magnet)
M9N(M)(L)(Z)	D-M9N(M)(L)(Z)	Solid state auto switch
M9P(M)(L)(Z)	D-M9P(M)(L)(Z)	
M9B(M)(L)(Z)	D-M9B(M)(L)(Z)	
A90(L)	D-A90(L)	Reed auto switch
A93(M)(L)(Z)	D-A93(M)(L)(Z)	(Flange size 16 is not available.)
M9//	—	Without auto switch (with built-in magnet)

Auto switches are not applicable for high-temperature specifications (Temperature specification H0). Standard lead wire length is 0.5 m. Add "L" to the end of the part number when 3 m is desired, "M" when 1 m, and "Z" when 5 m.
Ex.) -M9NL

⑦ Seal material and its changed part

• Seal material

Symbol	Seal material	Compound No.
Nil	FKM	1349-80*
N1	EPDM	2101-80*
P1	Barrel Perfluoro®	70W
Q1	Kalrez®	4079
R1	Chemraz®	SS592
R2		SS630
R3		SSE38
S1	VMQ	1232-70*
T1	FKM for Plasma	3310-75*
U1	ULTIC ARMOR®	UA4640

• Part numbers indicating changed seal material and leakage

Symbol	Changed part (Note 2)	Leakage (Pa·m ³ /s or less) (Note 1)	
		Internal	External
Nil	—	1.3 x 10 ⁻¹⁰ (FKM)	1.3 x 10 ⁻¹¹ (FKM)
A	②, ③	1.3 x 10 ⁻⁸	1.3 x 10 ⁻⁹
B	②	1.3 x 10 ⁻⁸	1.3 x 10 ⁻¹¹ (FKM)
C	③	1.3 x 10 ⁻¹⁰ (FKM)	1.3 x 10 ⁻⁹

Note 1) Values at ambient temperatures, excluding gas permeation.

Note 2) Refer to parts number of "Construction" on the page 485 for changed part. Number indicates parts number of "Construction" accordingly.

To order something else "Nil" (standard), list the symbols starting with "X," followed by each symbol for "seal material" and then "changed parts" at last.

Ex.) XMC-16-M9NA-XN1A

* Produced by Mitsubishi Cable Industries, Ltd.

Stainless steel High Vacuum Angle/In-line Valve **XMC, XYC Series**

Specifications

Model	XMC-16		XMC-25 XYC-25	XMC-40 XYC-40	XMC-50 XYC-50	XMC-63 XYC-63	XMC-80 XYC-80
Flange (Valve) size	16, CF034		25	40, CF070	50	63, CF114	80
Valve type	Double acting (Dual operation), pressurize to open/close						
Fluid	Inactive gas under vacuum						
Operating temperature (°C)	5 to 60 (High temperature type: 5 to 150)						
Operating pressure (Pa)(abs)	1 x 10 ⁻⁶ up to atmospheric pressure						
Conductance (L/s) ^{Note 1)}	5		14	45	80	160	200
Leakage (Pa·m ³ /s)	Internal	1.3 x 10 ⁻¹⁰ {1 x 10 ⁻¹⁰ } at ambient temperatures, excluding gas permeation (Standard material: FKM)					
	External	1.3 x 10 ⁻¹¹ {1 x 10 ⁻¹¹ } at ambient temperatures, excluding gas permeation (Standard material: FKM)					
Operating time (s)	0.08		0.15	0.35	0.4	0.54	0.7
Flange type	KF (NW), CF		KF (NW)	KF (NW), CF	KF (NW)	KF (NW), K (DN), CF	KF (NW), K (DN)
Principle materials	Body: SCS13 (Conforms to Stainless steel 304) Bellows: Stainless steel 316L Bellows holder: Stainless steel 304. FKM (Standard seal material)						
Pilot pressure (MPa)(G)	0.3 to 0.6				0.4 to 0.6		
Pilot port size	M5			Rc 1/8			
Weight (kg) ^{Note 2)}	XMC	0.36 (0.40)	0.62	1.40 (1.76)	2.10	3.80 (5.16)	6.30
	XYC	—	0.67	1.42	2.50	4.50	7.80

Note 1) Conductance is the value for the molecular flow of an elbow having the same dimensions.

Note 2) Figures in () indicates the weight of CF (conflate) fittings.

Construction

XMC/Angle type

XYC/In-line type

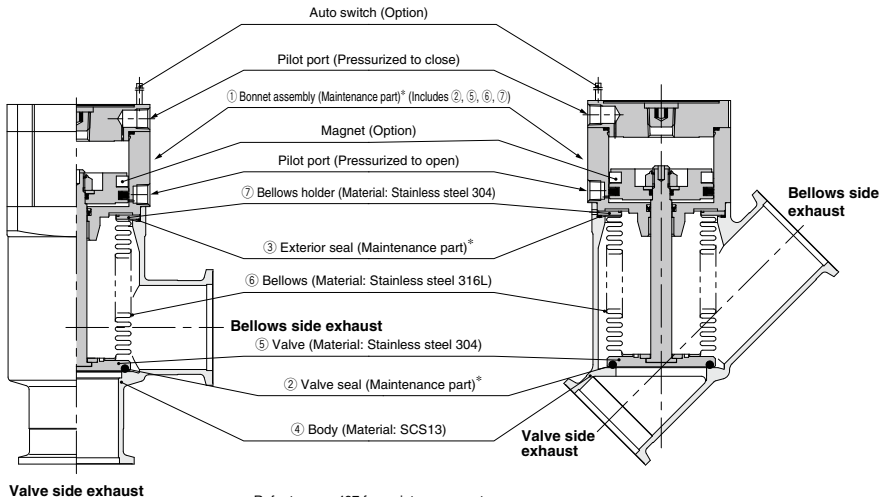

* Refer to page 497 for maintenance parts.

XL

XL□

XL□Q

XM□

XY□

D-□

XSA

XVD

XGT

CVV

XMC, XYC Series

Dimensions

XMC-16 to 40/Angle type

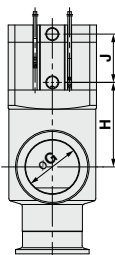
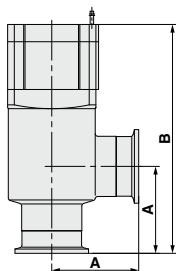
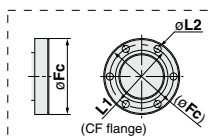
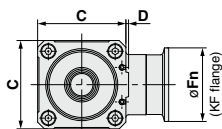

Model	A	B	C	D	F _n	F _c	G	H	J	P.C.D L1	L2
XMC-16	40	110	38	1	30	34	17	40	26	P.C.D 27	6 x $\phi 4.4$
XMC-25	50	120	48	1	40	—	26	39	28	—	—
XMC-40	65	171	66	2	55	70	41	63	36	P.C.D 58.7	6 x $\phi 6.6$

(mm)

XMC-50 to 80/Angle type

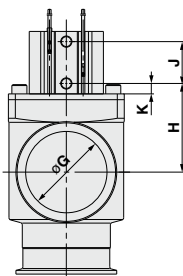
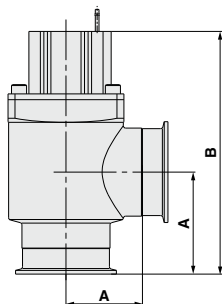
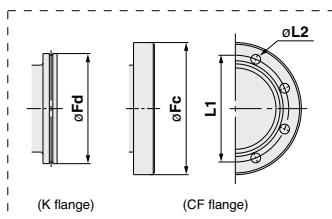
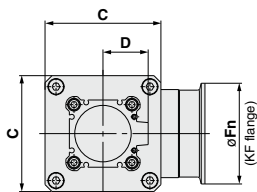

Model	A	B	C	D	F _n	F _d	F _c	G	H	J	P.C.D L1	L2	K
XMC-50	70	183	80	31	75	—	—	52	77	29	—	—	10.5
XMC-63	88	209	100	39	87	95	114	70	76.5	36	P.C.D 92.1	8 x $\phi 8.4$	9
XMC-80	90	250	117	45.5	114	110	—	83	105	44	—	—	9

(mm)

Dimensions

XYC-25, 40/In-line type

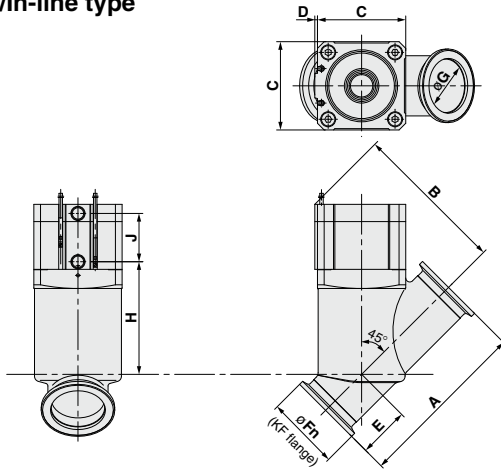

(mm)

Model	A	B	C	D	E	F _n	G	H	J
XYC-25	100.2	85	48	1	23.5	40	26	64	28
XYC-40	130	115	66	2	38	55	41	84	36

XYC-50 to 80/In-line type

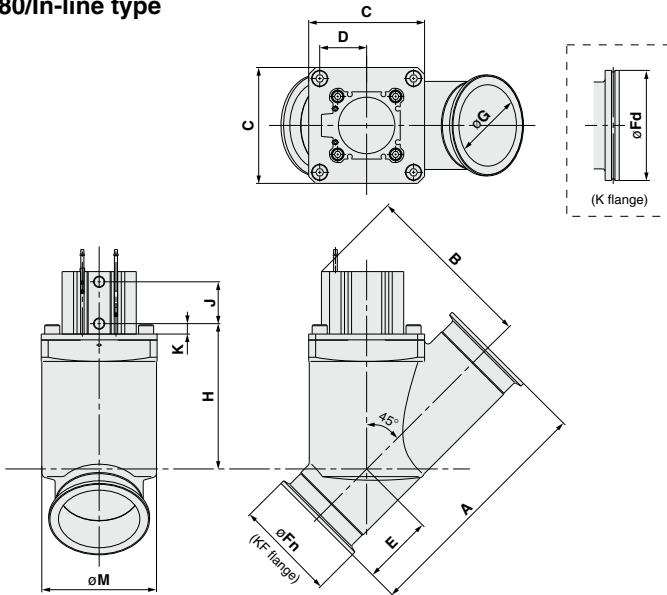

(mm)

Model	A	B	C	D	E	F _n	F _d	G	H	J	K	M
XYC-50	178	121	80	31	53	75	—	52	104	29	10.5	78
XYC-63	209	148	100	39	61	87	95	70	126	36	9	99
XYC-80	268	177	117	45.5	80	114	110	83	150	44	9	116

- XLA
- XL□
- XL□Q
- XLM□
- XY□
- D-□
- XSA
- XVD
- XGT
- CYV

Stainless steel High Vacuum Angle/In-line Valve 2 Stage Control, Single Acting/Bellows, O-ring Seal

PAT.

XMD, XYD Series



How to Order

Angle type

XMD - 25 [] [] [] - M9N A - []

In-line type

XYD - 25 [] [] [] - M9N A - []

Note) The XMDV and XYDV series with solenoid valve are also available. Please contact SMC for details.

① ② ③ ④ ⑤ ⑥ ⑦



① Flange size

Size	XMD	XYD
25	●	●
40	●	●
50	●	●
63	●	●
80	●	●

② Flange type XMD

Symbol	Type	Applicable flange size
Nil	KF (NW)	25, 40, 50, 63, 80
D	K (DN)	63, 80
C	CF	40 (070), 63 (114)

XYD

Nil	KF (NW)	25, 40, 50, 63, 80
D	K (DN)	63, 80

③ Pilot port direction XMD

Symbol	Pilot port direction
Nil	Flange side
K	Left flange surface
L	Rear flange surface
M	Right flange surface

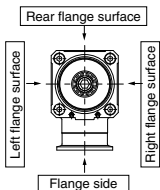

XYD

Symbol	Pilot port direction
Nil	Rear flange surface
K	Left flange surface
M	Right flange surface

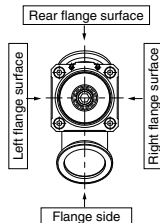

④ Temperature specifications

Symbol	Temperature range
Nil	5 to 60°C
H0	5 to 150°C

⑥ Number of auto switches/Detecting position

Symbol	Quantity	Detecting position
Nil	Without auto switch	—
A	2 pcs.	Valve open/closed
B	1 pc.	Valve open
C	1 pc.	Valve closed

⑤ Auto switch type

Symbol	Auto switch	Remarks
Nil	—	Without auto switch (without built-in magnet)
M9N(M)(L)(Z)	D-M9N(M)(L)(Z)	Solid state auto switch
M9P(M)(L)(Z)	D-M9P(M)(L)(Z)	
M9B(M)(L)(Z)	D-M9B(M)(L)(Z)	
A90(L)	D-A90(L)	Reed auto switch
A93(M)(L)(Z)	D-A93(M)(L)(Z)	(Flange size 16 is not available.)
M9//	—	Without auto switch (with built-in magnet)

Auto switches are not applicable for high-temperature specifications (Temperature specification H0). Standard lead wire length is 0.5 m. Add "L" to the end of the part number when 3 m is desired, "M" when 1 m, and "Z" when 5 m.
Ex.) -M9NL

⑦ Seal material and its changed part

• Seal material

Symbol	Seal material	Compound No.
Nil	FKM	1349-80*
N1	EPDM	2101-80*
P1	Barrel Perfluoro [®]	70W
Q1	Kalrez [®]	4079
R1	Chemraz [®]	SS592
R2		SS630
R3		SSE38
S1	VMQ	1232-70*
T1	FKM for Plasma	3310-75*
U1	ULTIC ARMOR [®]	UA4640

• Part numbers indicating changed seal material and leakage

Symbol	Changed part (Note 2)	Leakage (Pa·m ³ /s or less) (Note 1)	
		Internal	External
Nil	—	1.3 x 10 ⁻¹⁰ (FKM)	1.3 x 10 ⁻¹¹ (FKM)
A	②, ③, ④, ⑤	1.3 x 10 ⁻⁸	1.3 x 10 ⁻⁹
B	②, ④, ⑤	1.3 x 10 ⁻⁸	1.3 x 10 ⁻¹¹ (FKM)
C	③	1.3 x 10 ⁻¹⁰ (FKM)	1.3 x 10 ⁻⁹

Note 1) Values at ambient temperatures, excluding gas permeation.

Note 2) Refer to parts number of "Construction" on the page 490 for changed part. Number indicates parts number of "Construction" accordingly.

To order something else "Nil" (standard), list the symbols starting with "X," followed by each symbol for "seal material" and then "changed parts" at last.

Ex.) XMD-25-M9NA-XN1A

The material used in the sliding part of the S-valve is: FKM * Produced by Mitsubishi Cable Industries, Ltd.

Stainless steel **XMD, XYD Series**

High Vacuum Angle/In-line Valve

Specifications

Model		XMD-25 XYD-25	XMD-40 XYD-40	XMD-50 XYD-50	XMD-63 XYD-63	XMD-80 XYD-80
Flange (Valve) size		25	40, CF070	50	63, CF114	80
Valve type		Normally closed (Pressurize to open, spring seal) [both main & initial exhaust valves]				
Fluid		Inactive gas under vacuum				
Operating temperature (°C)		5 to 60 (High temperature type: 5 to 150)				
Operating pressure (Pa)(abs)		1 x 10 ⁻⁶ up to atmospheric pressure				
Conductance (L/s) <small>Note 1)</small>	Main exhaust valve	14	45	80	160	200
	Initial exhaust valve	0.5 to 3	2 to 8	2.5 to 11	4 to 18	4 to 18
Leakage (Pa·m³/s)	Internal	1.3 x 10 ⁻¹⁰ {1 x 10 ⁻¹⁰ } at ambient temperatures, excluding gas permeation (Standard material: FKM)				
	External	1.3 x 10 ⁻¹¹ {1 x 10 ⁻¹¹ } at ambient temperatures, excluding gas permeation (Standard material: FKM)				
Operating time (s)	Main exhaust valve	0.10	0.21	0.24	0.26	0.28
	Initial exhaust valve	0.07	0.08	0.09	0.23	0.27
Flange type		KF (NW)	KF (NW), CF	KF (NW)	KF (NW), K (DN), CF	KF (NW), K (DN)
Principle materials <small>Note 3)</small>		Body: SCS13 (Conforms to Stainless steel 304) Bellows: Stainless steel 316L Bellows holder: Stainless steel 304. FKM (Standard seal material)				
Pilot pressure (MPa)(G)		0.4 to 0.7 [both main and initial exhaust valves]				
Pilot port size		M5	Rc 1/8			
Weight (kg) <small>Note 2)</small>	XMD	0.65	1.50 (1.86)	2.20	4.10 (5.46)	6.80
	XYD	0.71	1.52	2.60	4.80	8.30

Note 1) Main exhaust valve conductance is the valve for the molecular flow of an elbow having the same dimensions. The initial exhaust valve is the value for the viscous flow.

Note 2) Figures in () indicates the weight of CF (conflate) fittings.

Note 3) A coating of vacuum grease [Y-VAC2] is applied to the seal-material sliding portion (initial exhaust valves sliding parts) of the vacuum part.

XLA

XL□

XL□Q

XMD□

XY□

D-□

XSA

XVD

XGT

CVV

XMD, XYD Series

Construction

XMD/Angle type

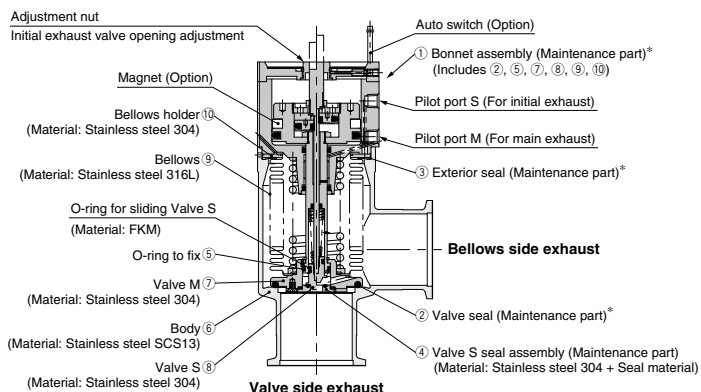

XYD/In-line type

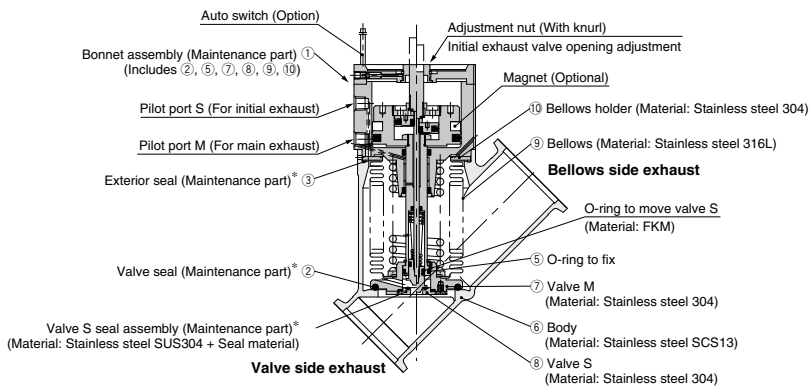

* Refer to page 497 for maintenance parts.

<Operating principle> XMD, XYD Series

1 Initial exhaust valve opening adjustment

The initial exhaust rate should be adjusted without applying the pilot pressure to the pilot port S before operation. The initial exhaust rate is set to zero by gently turning the adjustment nut clockwise until it stops. (Do not use any tools.) The initial exhaust rate is adjusted by turning the adjustment nut counterclockwise. The number of adjustment nut (its pitch is 1 mm) rotations and initial exhaust conductance should be confirmed referring to the figure on the right.

2 Opening of the initial exhaust valve (valve S)

When the pilot pressure is applied to the pilot port S, the valve S is removed from the valve S seal assembly, and the valve opens the adjusted amount.

3 Opening of the main exhaust valve (valve M)

When the pilot pressure is applied to the pilot port M, the valve M is removed from the body seat portion, and the valve fully opens.

4 Closing of the initial exhaust valve, the main exhaust valve

By removing the pilot pressure from the pilot port S and pilot port M, both S and M valves return to their previous positions and they are sealed.

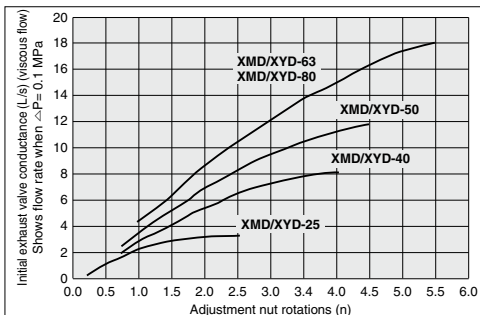

Dimensions

XMD/Angle type

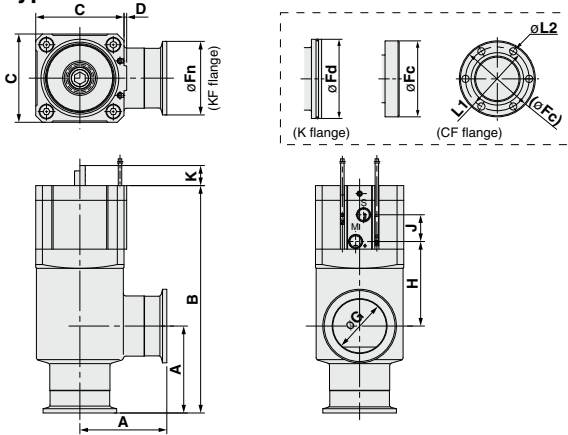

Model	A	B	C	D	F _n	F _d	F _c	G	H	J	K	P.C.D L1	L2
XMD-25	50	123	48	1	40	—	—	26	41	16	7.5	—	—
XMD-40	65	170	66	2	55	—	70	41	63	20	15	P.C.D 58.7	6 x $\phi 6.6$
XMD-50	70	183	79	2	75	—	—	52	68	20	17.5	—	—
XMD-63	88	217	100	3	87	95	114	70	72	20	19.5	P.C.D 92.1	8 x $\phi 8.4$
XMD-80	90	256	117	3	114	110	—	83	98	20	26.5	—	—

XYD/In-line type

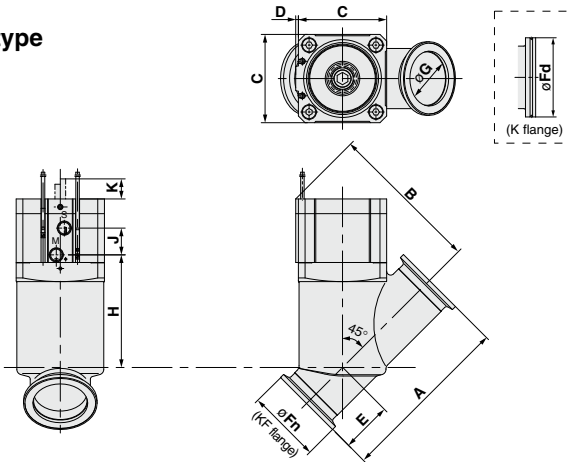

Model	A	B	C	D	E	F _n	F _d	G	H	J	K
XYD-25	100.2	86.7	48	1	23.5	40	—	26	66	16	7.5
XYD-40	130	114	66	2	38	55	—	41	84	20	15
XYD-50	178	128	79	2	53	75	—	52	95	20	17.5
XYD-63	209	163	100	3	61	87	95	70	121	20	19.5
XYD-80	268	193	117	3	80	114	110	83	144	20	26.5

- XLA**
- XL**
- XLQ**
- XMD**
- XY**
- D-**
- XSA**
- XVD**
- XGT**
- CVV**

Stainless steel High Vacuum Angle/In-line Valve Manual Valve/Bellows Seal ***XMH, XYH Series***

RoHS



How to Order

Angle type

XMH - 16 - [] - []

In-line type

XYH - 25 - [] - []

① ② ③



① Flange size

Size	XMH	XYH
16	●	—
25	●	●
40	●	●
50	●	●

② Flange type

XMH

Symbol	Type	Applicable flange size
Nll	KF (NW)	16, 25, 40, 50
C	CF	16 (034), 40 (070)

XYH

Nll	KF (NW)	25, 40, 50
-----	---------	------------

③ Seal material and its changed part

• Seal material

Symbol	Seal material	Compound No.
Nll	FKM	1349-80*
N1	EPDM	2101-80*
P1	Barrel Perfluoro®	70W
Q1	Kalrez®	4079
R1	Chemraz®	SS592
R2		SS630
R3		SSE38
S1	VMQ	1232-70*
T1	FKM for Plasma	3310-75*
U1	ULTIC ARMOR®	UA4640

*: Produced by Mitsubishi Cable Industries, Ltd.

• Part numbers indicating changed seal material and leakage

Symbol	Changed part <small>Note 2)</small>	Leakage (Pa·m ³ /s or less) <small>Note 1)</small>	
		Internal	External
Nll	—	1.3 x 10 ⁻¹⁰ (FKM)	1.3 x 10 ⁻¹¹ (FKM)
A	②, ③	1.3 x 10 ⁻⁸	1.3 x 10 ⁻⁹
B	②	1.3 x 10 ⁻⁸	1.3 x 10 ⁻¹¹ (FKM)
C	③	1.3 x 10 ⁻¹⁰ (FKM)	1.3 x 10 ⁻⁹

Note 1) Values at ambient temperatures, excluding gas permeation.

Note 2) Refer to parts number of "Construction" on the page 493 for changed part. Number indicates parts number of "Construction" accordingly.

To order something else "Nil" (standard), list the symbols starting with "X", followed by each symbol for "seal material" and then "changed parts" at last.

Ex.) XMH-16-XN1A

Stainless steel High Vacuum Angle/In-line Valve **XMH, XYH Series**

Specifications

Model	XMH-16	XMH-25 XYH-25	XMH-40 XYH-40	XMH-50 XYH-50
Flange (valve) size	16, CF034	25	40, CF070	50
Valve type	Manual type			
Fluid	Inactive gas under vacuum			
Operating temperature (°C)	5 to 150			
Operating pressure (Pa)(abs)	1 x 10 ⁻⁶ up to atmospheric pressure			
Conductance (L/s) ^{Note 1)}	5	14	45	80
Leakage (Pa·m ³ /s)	Internal	1.3 x 10 ⁻¹⁰ {1 x 10 ⁻¹⁰ } at ambient temperature, excluding gas permeation (Standard material: FKM)		
	External	1.3 x 10 ⁻¹¹ {1 x 10 ⁻¹¹ } at ambient temperature, excluding gas permeation (Standard material: FKM)		
Flange type	KF (NW), CF	KF (NW)	KF (NW), CF	KF (NW)
Principle materials	Body: SCS13 (Conforms to Stainless steel SUS304), Bellows: Stainless steel SUS316L, Bellows holder: Stainless steel SUS304. FKM (Standard seal material)			
Pilot torque (N·m)	0.1 ≤	0.15 ≤	0.35 ≤	0.5 ≤
Handle revolutions	5	7	10	13
Weight (kg) ^{Note 2)}	XMH	0.31 (0.35)	0.57	1.35 (1.71)
	XYH	—	0.62	1.37

Note 1) Conductance is the value for the molecular flow of an elbow having the same dimensions.

Note 2) Figures in () indicates the weight of CF (conflate) fittings.

Construction

XMH/Angle type

XYH/In-line type

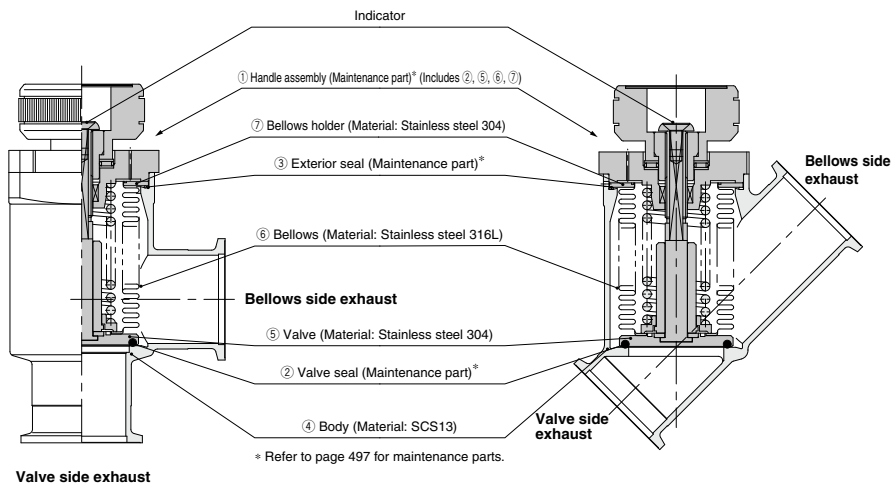

XLA
XL□
XL□Q
XM□
XY□
D-□
XSA
XVD
XGT
CVV

XMH, XYH Series

Dimensions

XMH/Angle type

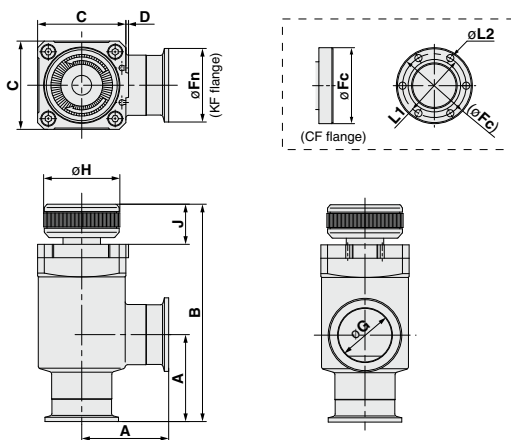

Model	A	B	C	D	F _n	F _c	G	H	J	P.C.D L1	L2
XMH-16	40	100.5	38	1	30	34	17	35	18	P.C.D 27	6 x ϕ 4.4
XMH-25	50	114	48	1	40	—	26	40.5	21.5	—	—
XMH-40	65	162.5	66	2	55	70	41	57	30	P.C.D 58.7	6 x ϕ 6.6
XMH-50	70	179.5	79	2	75	—	52	70	35	—	—

XYH/In-line type

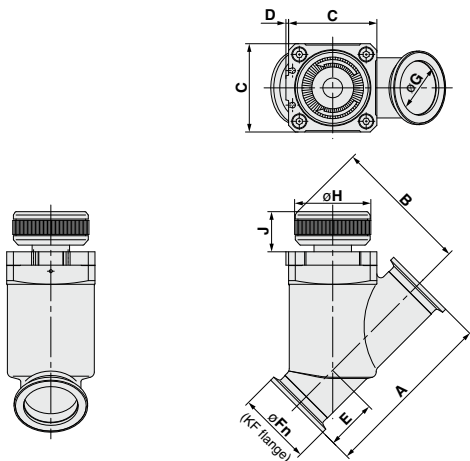

Model	A	B	C	D	E	F _n	G	H	J
XYH-25	100.2	75.8	48	1	23.5	40	26	40.5	21.5
XYH-40	130	102.5	66	2	38	55	41	57	30
XYH-50	178	119	79	2	53	75	52	70	35

XMH, XYH Series Glossary

1 Seal Materials

Please note that the following are general features and subject to change depending on processing conditions. For details, please contact sealing component manufacturers.

FKM (Fluororubber)

With low outgassing, low permanent-setting and low gas permeation rates, this is the most popular seal material for high vacuums. Standard material used by SMC's high vacuum angle valve is Mitsubishi Cable Industries, Ltd. (Compound No. 1349-80). It is advisable to choose a model depending on its application, because an improved material compound (3310-75) which reduces the weight reduction ratio with O₂ plasma is also available.

Kalrez[®] * Kalrez[®] is a registered trademark of E. I. du Pont de Nemours and Company or its affiliates. This material, perfluoroelastomer (FFKM), has excellent heat and chemical resistance, but its permanent-setting is large, and special caution is required. Variations are available with improved plasma (O₂, CF₄) and particulate resistance; therefore it is advisable to select types based upon the application. Compound No. 4079: Standard Kalrez[®], excellent in gas and heat resistance.

Chemraz[®] * Chemraz[®] is a registered trademark of Greene, Tweed & Co. This material, perfluoroelastomer (FFKM), has excellent chemical and plasma resistance and has slightly higher heat resistance than FKM. Several variations of Chemraz[®] are available and it is advisable to choose based upon the particular plasma being used and other conditions, etc.

Compound No. SS592: Excellent physical properties and especially effective for moving parts.

Compound No. SS630: Applicable to both fixed and moving parts and compatible with a wide variety of applications.

Compound No. SSE38: The cleanest material among Chemraz[®], developed for high-density plasma instruments.

Barrel Perfluoro[®] * Barrel Perfluoro[®] is a registered trademark of Matsumura Oil Co., Ltd. Compound No. 70W: Perfluoroelastomer (FFKM) which does not contain a metal filler. Resistant against NF₃, NH₃. Low particle generation under dry process conditions.

ULTIC ARMOR[®] * ULTIC ARMOR[®] is a registered trademark of Nippon Valqua Industries, Ltd. Fluoro-based rubber which does not contain a metal filler. Seal material which is plasma-resistant and has low gas emittance and heat resistance.

Silicone (Silicone rubber, VMQ)

This material is relatively inexpensive, has good plasma resistance, but its gas permeation rate is high. Optional seal material used by SMC's high vacuum angle valve is Mitsubishi Cable Industries, Ltd. (Compound No. 1232-70, White) It has a low weight-reduction ratio and low particle generation within O₂ plasma and NH₃ gas environments.

EPDM (Ethylenepropylene rubber)

Relatively lower priced and excellent in weatherability, chemical and heat resistance, but with no resistance at all to general mineral oil. Optional seal material used by SMC's high vacuum angle valve is Mitsubishi Cable Industries, Ltd. (Compound No. 2101-80) Resistant to NH₃ gas, etc.

2 Shaft Sealing Method

Bellows

Bellows offer cleaner sealing with reduced particle generation and less outgassing. The two major bellows types are: Formed-bellows and Welded-bellows. Formed-bellows produce less dusts and offer higher dust resistance. Welded-bellows allow longer strokes, but generate more dust particles and offer less dust resistance. Please note, the endurance depends on length and speed of the strokes.

3 Response time/Operation time

Valve opening

The time from the application of voltage to the actuation solenoid valve until 90% of the valve stroke has been completed is the valve opening response time. Valve opening operation time indicates the time from the start of the stroke until 90% of movement has been completed. Both of these become faster as the operating pressure is increased.

Valve closing

The time from the cut off of power to the actuation solenoid valve until 90% of the valve return stroke has been completed is the valve closing response time. Valve closing operation time indicates the time from valve opening until 90% of return movement has been completed. Both of these become slower as the operating pressure is increased.

XLA

XL□

XL□Q

XM□
XY□

D-□

XSA

XVD

XGT

CYV



XM, XY Series

Specific Product Precautions 1

Be sure to read this before handling the products.

Precautions on Design

⚠ Warning

• All models

1. The body material is SCS13 (conforms to Stainless steel 304), the bellows is Stainless steel 316L, and other metal seal material is Stainless steel 304. Standard seal material in the vacuum section is FKM that can be changed to the other materials (please refer "How to Order"). Use fluids those are compatible with using materials after confirming.
2. Select materials for the actuation pressure piping, and heat resistance for fittings that are suitable for the applicable operating temperatures.

• Model with auto switch

1. The switch section should be kept at a temperature no greater than 60°C.

Selection

⚠ Caution

• All models

1. When controlling valve responsiveness, take note of the size and length of piping, as well as the flow rate characteristics of the actuating solenoid valve.
2. Actuating pressure should be kept within the specified range. 0.4 to 0.5 MPa is recommended.
3. Use within the limits of the operating pressure range.
4. The actuating piston chamber and the bellows chamber are directly connected to the atmosphere. Please use in an environment in which dust emissions will not cause problems.

• High temperature types

1. In the case of gases which cause a large amount of deposits, heat the valve body to prevent deposits in the valve.

Mounting

⚠ Caution

• All models

1. In high humidity environments keep valves packaged until the time of installation.
2. In case with switches, secure the lead wires so that they have sufficient slack, without any unreasonable force applied to them.
3. Perform piping so that excessive force is not applied to the flange sections. In case there is vibration of heavy objects or attachments, etc., secure them so that torque is not applied directly to the flanges.
4. Vibration resistance allows for normal operation up to 30 m/s² (45 to 250 Hz), but continuous vibration may cause a decline in durability. Arrange piping to avoid excessive vibrations or shocks.

• High temperature types (Models/XMH, XYH; Temperature specifications/H0)

1. When a valve is to be heated, only the body section should be heated, excluding the bonnet (handle) section.

Piping

⚠ Caution

1. Before mounting, clean the surface of the flange seal and the O-ring with ethanol, etc.
2. There is an indentation of 0.1 to 0.2 mm in order to protect the flange seal surface, and it should be handled so that the seal surface is not damaged in any way.
3. Exhaust direction
During operation, the direction of the exhaust may be determined freely, but in cases where a flow is generated by the exhaust, a decline in durability may result. The exhaust direction shown in the figure below (bellows side exhaust) is recommended.
Please take all available precautions, as the life of the equipment is affected by conditions of usage.

Recommended exhaust direction [Vacuum pump connected on bellows side]

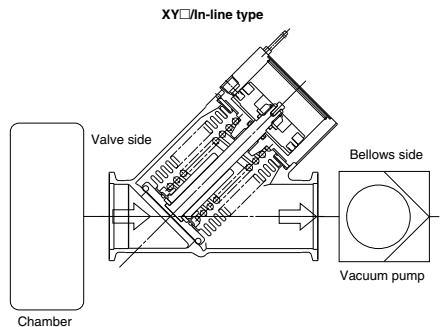
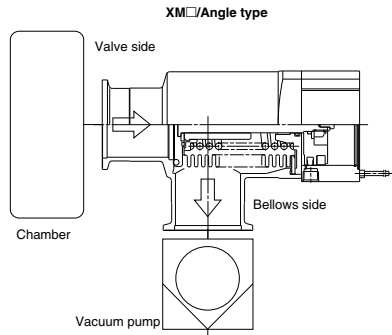



XM, XY Series

Specific Product Precautions 2

Be sure to read this before handling the products.

Maintenance

⚠ Caution

- When removing deposits from a valve, take care not to damage any of its parts.
- Replace the bonnet assembly and the O-ring when the end of its service life is approached.
- If damage is suspected prior to the end of the service life, perform early maintenance.
- SMC specified parts should be used for service. Refer to the Construction/Maintenance parts table.
- When removing seal material (such as valve, exterior seals), take care not to damage the sealing surfaces. When installing the valve and exterior seals, be sure that the O-ring is not twisted.

Maintenance Parts

⚠ Caution

- The bonnet or handle assembly should also be replaced when changing the seal material.
Due to the different materials used, changing only the seal may prove inadequate.

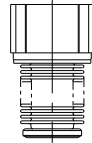

Bonnet assembly

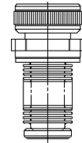

Handle assembly

Bonnet & Handle assembly/Construction part number: 1

Model	Temperature specifications	Indicator	Valve size					
			16	25	40	50	63	80
XMA XYA	General use	—	XLA16-30-1	XLA25-30-1	XLA40-30-1	XLA50-30-1	XLA63-30-1	XLA80-30-1
	High temperature	○	XLA16A-30-1	XLA25A-30-1	XLA40A-30-1	XLA50A-30-1	XLA63A-30-1	XLA80A-30-1
XMC XYC	General use	—	XLC16-30-1	XLC25-30-1	XLC40-30-1	XLC50-30-1	XLC63-30-1	XLC80-30-1
	High temperature	—	XLC16-30-1H	XLC25-30-1H	XLC40-30-1H	XLC50-30-1H	XLC63-30-1H	XLC80-30-1H
XMD XYD	General use	○	—	XLD25-30-1	XLD40-30-1	XLD50-30-1	XLD63-30-1	XLD80-30-1
	High temperature	Standard	—	XLD25-30-1H	XLD40-30-1H	XLD50-30-1H	XLD63-30-1H	XLD80-30-1H
XMH XYH	High temperature as standard	○	Standard	Standard	Standard	Standard	Standard	Standard
	Standard	Standard	XLH16-30-1	XLH25-30-1	XLH40-30-1	XLH50-30-1	—	—

Note 1) List the optional seal material symbol (refer to Table 1 below) after the model number, except for the standard seal material (FKM: compound no. 1349-80, produced by Mitsubishi Cable Industries, Ltd.)

Note 2) An auto switch magnet is not attached. In cases where an auto switch magnet is attached, please add "M9/" at the end of the part number. (Not available for high temperature models)

Note 3) Auto switch and solenoid valve are not attached. When a set including auto switch and solenoid valve is required, please add the symbols after the auto switch in "How to Order" at the end of the part number.

Exterior seal, (M) Valve seal, S Valve seal assemblies

Model	Description Construction no.	Material	Valve size					
			16	25	40	50	63	80
XMA XYA XMC XYC XMH XYH XMD XYD	Exterior seal ③	Standard	AS568-025V	AS568-030V	AS568-035V	AS568-039V	AS568-043V	AS568-045V
		Special	AS568-025□	AS568-030□	AS568-035□	AS568-039□	AS568-043□	AS568-045□
XMH XYH XMD XYD	Valve seal ②	Standard	B2401-V15V	B2401-V24V	B2401-P42V	AS568-227V	AS568-233V	B2401-V85V
		Special	B2401-V15□	B2401-V24□	B2401-P42□	AS568-227□	AS568-233□	B2401-V85□
XMD XYD	S Valve seal assembly ④	Standard	—	AS568-009V	XLD40-2-9-1A AS568-016V	XLD50-2-9-1A AS568-016V	XLD63-2-9-1A	XLD80-2-9-1A
		Special	—	AS568-009□	XLD40-2-9-1A□ AS568-016□	XLD50-2-9-1A□ AS568-016□	XLD63-2-9-1A□	XLD80-2-9-1A□

Note 1) List the optional seal material symbol (refer to Table 1 below) after the model number, except for the standard seal material (FKM: compound no. 1349-80, produced by Mitsubishi Cable Industries, Ltd.)

Note 2) Refer to the Construction of each series for the construction numbers.

Table 1

Optional seal material

Symbol	-XN1	-XP1	-XQ1	-XR1	-XR2	-XR3	-XS1	XT1	-XU1
Seal material	EPDM	Barrel® Perfluoro	Kalrez®		Chemraz®		VMQ	FKM for Plasma	ULTIC ARMOR®
Compound No.	2101-80*	70W	4079	SS592	SS630	SSE38	1232-70*	3310-75*	UA4640

Note) Due to the different materials used, changing only the seal may prove inadequate.

*: Produced by Mitsubishi Cable Industries, Ltd.

XLA

XL□

XL□Q

XMI□

XY□

D-□

XSA

XVD

XGT

CVY