

# Body Ported Type Vacuum Ejector

## ZH Series

RoHS

### Compact and Lightweight

Overall length **Max. 11% reduction**  
(6.7 mm shorter)

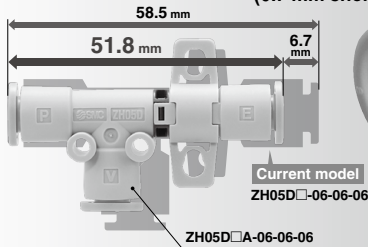

- ZK2
- ZQ
- ZR
- ZB
- ZA
- ZX
- ZM
- ZL
- ZH**
- ZH-X267
- ZHP
- ZU
- VQD-V

Port height **Max. 25% reduction** (9.1 mm shorter)

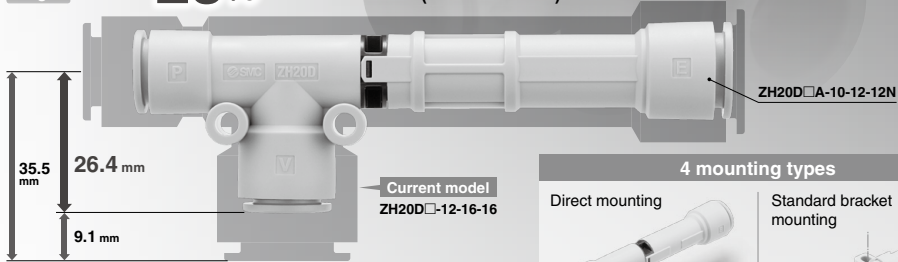

Weight **Max. 74% reduction** (65.1 g lighter)



#### 4 mounting types

**Direct mounting**

**Standard bracket mounting**

**L-bracket mounting**

**DIN rail mounting**

#### Variations

Model	Nozzle nominal size [mm]	Vacuum pressure reached* [kPa]		Maximum suction flow rate [L/min (ANR)]		Air consumption [L/min (ANR)]
		Type S	Type L	Type S	Type L	
ZH05D□A	0.5	-90	-48	6	13	13
ZH07D□A	0.7			12	28	27
ZH10D□A	1.0			26	52	52
ZH13D□A	1.3			40	78	84
ZH15D□A	1.5	-66	-66	58	78	113
ZH18D□A	1.8			76	128	162
ZH20D□A	2.0			90	155	196

\* Supply pressure: 0.45 MPa

## Piping Variations

### One-touch connection

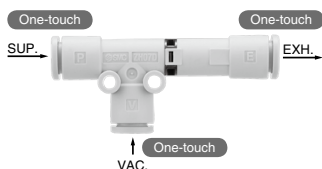

Metric			
SUP.	VAC.	EXH.	Model
ø6*	ø6*	ø6*	ZH05D□A ZH07D□A
ø6*	ø6*	ø8	ZH10D□A
ø8	ø10	ø10	ZH13D□A ZH15D□A
ø10	ø12	ø12	ZH18D□A ZH20D□A

Inch			
SUP.	VAC.	EXH.	Model
ø1/4"	ø1/4"	ø1/4"	ZH05D□A ZH07D□A
ø1/4"	ø1/4"	ø5/16"	ZH10D□A
ø5/16"	ø3/8"	ø3/8"	ZH13D□A ZH15D□A
ø3/8"	ø1/2"	ø1/2"	ZH18D□A ZH20D□A

\* Oval release button is only available with ø6.

### One-touch and screw-in connection

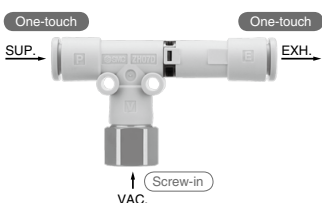

SUP.	VAC.	EXH.	Model
ø6*	Rc1/8	ø6*	ZH05D□A ZH07D□A
ø8	Rc1/8	ø8	ZH10D□A
ø8	Rc1/4	ø10	ZH13D□A
ø8	Rc3/8	ø10	ZH15D□A
ø10	Rc3/8	ø12	ZH18D□A
ø10	Rc1/2	ø12	ZH20D□A

SUP.	VAC.	EXH.	Model
ø1/4"	NPT1/8	ø1/4"	ZH05D□A ZH07D□A
ø1/4"	NPT1/8	ø5/16"	ZH10D□A
ø5/16"	NPT1/4	ø3/8"	ZH13D□A
ø5/16"	NPT3/8	ø3/8"	ZH15D□A
ø3/8"	NPT3/8	ø1/2"	ZH18D□A
ø3/8"	NPT1/2	ø1/2"	ZH20D□A

\* Oval release button is only available with ø6.

### Screw-in connection

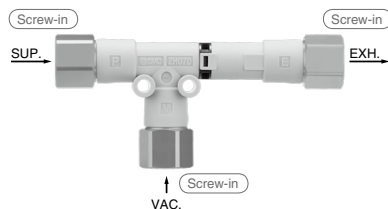

SUP.	VAC.	EXH.	Model
Rc1/8	Rc1/8	Rc1/8	ZH05D□A ZH07D□A ZH10D□A
Rc1/8	Rc1/4	Rc1/4	ZH13D□A
Rc1/4	Rc3/8	Rc3/8	ZH15D□A
Rc3/8	Rc3/8	Rc3/8	ZH18D□A
Rc3/8	Rc1/2	Rc1/2	ZH20D□A

SUP.	VAC.	EXH.	Model
NPT1/8	NPT1/8	NPT1/8	ZH05D□A ZH07D□A ZH10D□A
NPT1/8	NPT1/4	NPT1/4	ZH13D□A
NPT1/4	NPT3/8	NPT3/8	ZH15D□A
NPT3/8	NPT3/8	NPT3/8	ZH18D□A
NPT3/8	NPT1/2	NPT1/2	ZH20D□A

## Easy identification of product type

	Release button color	
Metric		Light gray
Inch		Orange

## Silencer and standard bracket are available.

\* Shipped together with the product.

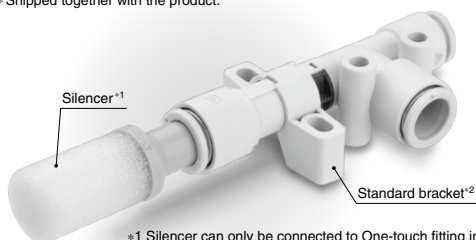

\*1 Silencer can only be connected to One-touch fitting in EXH. port.

\*2 Mounting is interchangeable with the current model. Refer to page 233 for mounting.

### Box Type Vacuum Ejector (Built-in Silencer)

Nozzle size: ø0.5, ø0.7, ø1.0, ø1.3

For details, refer to page 237.

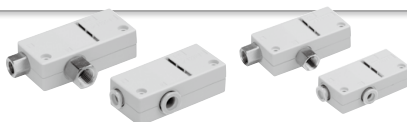

# Body Ported Type Vacuum Ejector

## ZH Series



### How to Order

**Note** Refer to "Table 1" and "Table 2" for the combination available for SUP., VAC. and EXH. port connection.

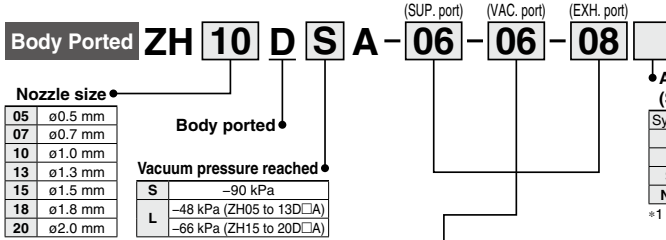

\*1 Options S and NS are not available for EXH. port with a screw-in connection.  
 \*2 Each accessory is not assembled with the product, but shipped together.

**Port (SUP./VAC./EXH.) size<sup>(Note)</sup>**

**One-touch fittings**

Metric size	Inch size
06 ø6	07 ø1/4"
08 ø8	09 ø5/16"
10 ø10	11 ø3/8"
12 ø12	13 ø1/2"

**Female threads**

Metric size	Inch size
01 Rc1/8	N01 NPT1/8
02 Rc1/4	N02 NPT1/4
03 Rc3/8	N03 NPT3/8
04 Rc1/2	N04 NPT1/2

Silencer can only be selected for EXH. port with One-touch fitting.  
 The silencer part number depends on the size of the EXH. port.

EXH. port	Silencer part no.
06	AN10-C06
07	AN10-C07
08	AN15-C08
09	AN15-C08
10	AN20-C10
11	AN20-C11
12	AN30-C12

\* No silencer available for ZH18/20D□A in inch size for EXH. port size '13'.  
 In that case, select the screw-in connection, and order silencer AN30-N03 and AN40-N04 separately.  
 For details about silencers, refer to the AN series in the Best Pneumatics No. 7.

**Note** Refer to "Table 1" and "Table 2" for the combination available for SUP., VAC. and EXH. port connection.

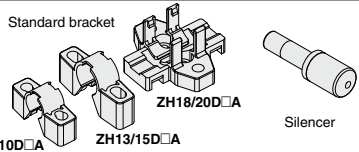

**Table 1 Metric Size**

Model	SUP. VAC. EXH.			SUP. VAC. EXH.		
	One-touch	One-touch	One-touch	One-touch	One-touch	One-touch
ZH05D□A	06 — 06 — 06	One-touch	One-touch	One-touch	One-touch	One-touch
	06 — 01 — 06	One-touch	Screw-in	One-touch	Screw-in	One-touch
	01 — 01 — 01	Screw-in	Screw-in	Screw-in	Screw-in	Screw-in
ZH07D□A	06 — 06 — 06	One-touch	One-touch	One-touch	One-touch	One-touch
	06 — 01 — 06	One-touch	Screw-in	One-touch	Screw-in	One-touch
	01 — 01 — 01	Screw-in	Screw-in	Screw-in	Screw-in	Screw-in
ZH10D□A	06 — 06 — 08	One-touch	One-touch	One-touch	One-touch	One-touch
	06 — 01 — 08	One-touch	Screw-in	One-touch	Screw-in	One-touch
	01 — 01 — 01	Screw-in	Screw-in	Screw-in	Screw-in	Screw-in
ZH13D□A	08 — 10 — 10	One-touch	One-touch	One-touch	One-touch	One-touch
	08 — 02 — 10	One-touch	Screw-in	One-touch	Screw-in	One-touch
	01 — 02 — 02	Screw-in	Screw-in	Screw-in	Screw-in	Screw-in
ZH15D□A	08 — 10 — 10	One-touch	One-touch	One-touch	One-touch	One-touch
	08 — 03 — 10	One-touch	Screw-in	One-touch	Screw-in	One-touch
	02 — 03 — 03	Screw-in	Screw-in	Screw-in	Screw-in	Screw-in
ZH18D□A	10 — 12 — 12	One-touch	One-touch	One-touch	One-touch	One-touch
	10 — 03 — 12	One-touch	Screw-in	One-touch	Screw-in	One-touch
	03 — 03 — 03	Screw-in	Screw-in	Screw-in	Screw-in	Screw-in
ZH20D□A	10 — 12 — 12	One-touch	One-touch	One-touch	One-touch	One-touch
	10 — 04 — 12	One-touch	Screw-in	One-touch	Screw-in	One-touch
	03 — 04 — 04	Screw-in	Screw-in	Screw-in	Screw-in	Screw-in

\*3 Screw-in: Rc female threads

**Table 2 Inch Size**

Model	SUP. VAC. EXH.			SUP. VAC. EXH.		
	One-touch	One-touch	One-touch	One-touch	One-touch	One-touch
ZH05D□A	07 — 07 — 07	One-touch	One-touch	One-touch	One-touch	One-touch
	07 — N01 — 07	One-touch	Screw-in	One-touch	Screw-in	One-touch
	N01 — N01 — N01	Screw-in	Screw-in	Screw-in	Screw-in	Screw-in
ZH07D□A	07 — 07 — 07	One-touch	One-touch	One-touch	One-touch	One-touch
	07 — N01 — 07	One-touch	Screw-in	One-touch	Screw-in	One-touch
	N01 — N01 — N01	Screw-in	Screw-in	Screw-in	Screw-in	Screw-in
ZH10D□A	07 — 07 — 09	One-touch	One-touch	One-touch	One-touch	One-touch
	07 — N01 — 09	One-touch	Screw-in	One-touch	Screw-in	One-touch
	N01 — N01 — N01	Screw-in	Screw-in	Screw-in	Screw-in	Screw-in
ZH13D□A	09 — 11 — 11	One-touch	One-touch	One-touch	One-touch	One-touch
	09 — N02 — 11	One-touch	Screw-in	One-touch	Screw-in	One-touch
	N01 — N02 — N02	Screw-in	Screw-in	Screw-in	Screw-in	Screw-in
ZH15D□A	09 — 11 — 11	One-touch	One-touch	One-touch	One-touch	One-touch
	09 — N03 — 11	One-touch	Screw-in	One-touch	Screw-in	One-touch
	N02 — N03 — N03	Screw-in	Screw-in	Screw-in	Screw-in	Screw-in
ZH18D□A	11 — 13 — 13	One-touch	One-touch	One-touch	One-touch	One-touch
	11 — N03 — 13	One-touch	Screw-in	One-touch	Screw-in	One-touch
	N03 — N03 — N03	Screw-in	Screw-in	Screw-in	Screw-in	Screw-in
ZH20D□A	11 — 13 — 13	One-touch	One-touch	One-touch	One-touch	One-touch
	11 — N04 — 13	One-touch	Screw-in	One-touch	Screw-in	One-touch
	N03 — N04 — N04	Screw-in	Screw-in	Screw-in	Screw-in	Screw-in

\*4 Screw-in: NPT female threads



ZK2  
 ZQ  
 ZR  
 ZB  
 ZA  
 ZX  
 ZM  
 ZL  
 ZH  
 ZH  
 ZH-X267  
 ZHP  
 ZU  
 VQD-V

## L-Bracket / DIN Rail Mounting Bracket

When using the ejectors with a clamp mount, order parts ①, ② and ③ below separately.

### ① L-Bracket

Part no.	Applicable model	Note	Quantity
<b>AS-10L</b>	ZH05/07/10D□A	Applicable thread size: M3	1 pc.
<b>AS-25L</b>	ZH13/15D□A	Applicable thread size: M4	
<b>AS-30L</b>	ZH18/20D□A	Applicable thread size: M4	

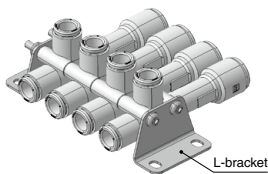

### ② DIN Rail Mounting Bracket<sup>\*1</sup>

Part no.	Applicable model	Note	Quantity
<b>AS-10D</b>	ZH05/07/10D□A	Applicable thread size: M3	1 pc.
<b>AS-25D</b>	ZH13/15D□A	Applicable thread size: M4	
<b>AS-30D</b>	ZH18/20D□A	Applicable thread size: M4	

\*1 DIN rail is not included. It should be provided by the customer.

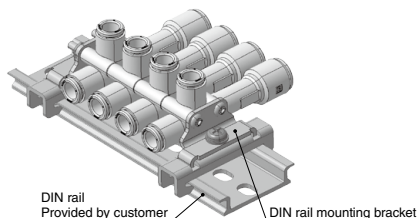

### ③ Set of Long Clamping Screws<sup>\*1</sup>

Part no.	Applicable model	Stations	Contents <sup>*2</sup>			
			Screw	Accessories		
<b>ZH2-TB101-A</b>	ZH05D□A ZH07D□A ZH10D□A	1	M3 x 20 2 pcs.	· Hexagon nut (M3) 2 pcs.  · Flat washer (for M3) 2 pcs.		
<b>ZH2-TB102-A</b>		2	M3 x 35 2 pcs.			
<b>ZH2-TB103-A</b>		3	M3 x 50 2 pcs.			
<b>ZH2-TB104-A</b>		4	M3 x 65 2 pcs.			
<b>ZH2-TB106-A</b>		6	M3 x 95 2 pcs.			
<b>ZH2-TB108-A</b>		8	M3 x 125 2 pcs.			
<b>ZH2-TB201-A</b>		ZH13D□A ZH15D□A	1		M4 x 30 2 pcs.	· Hexagon nut (M4) 2 pcs.  · Flat washer (for M4) 2 pcs.
<b>ZH2-TB202-A</b>			2		M4 x 50 2 pcs.	
<b>ZH2-TB203-A</b>	3		M4 x 70 2 pcs.			
<b>ZH2-TB204-A</b>	4		M4 x 90 2 pcs.			
<b>ZH2-TB206-A</b>	6		M4 x 130 2 pcs.			
<b>ZH2-TB208-A</b>	8		M4 x 170 2 pcs.			
<b>(ZH2-TB201-A)<sup>*3</sup></b>	ZH18D□A ZH20D□A		1	M4 x 30 2 pcs.		
<b>ZH2-TB302-A</b>			2	M4 x 55 2 pcs.		
<b>ZH2-TB303-A</b>		3	M4 x 80 2 pcs.			
<b>ZH2-TB304-A</b>		4	M4 x 100 2 pcs.			
<b>ZH2-TB306-A</b>		6	M4 x 145 2 pcs.			
<b>ZH2-TB308-A</b>		8	M4 x 185 2 pcs.			

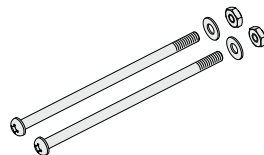

Set of long clamping screws

\*1 Select only One-touch fitting if ZH ejectors are to be clamped. The screw-in connectors cannot be used as they will interfere with each other when clamped together. Refer to page 230 and 231 to find the models for which clamp mounting is not available.

\*2 The material of the nut and bolt is carbon steel with a trivalent chromate surface treatment.

\*3 The same screw set is used for 1 station of ZH13/15D□A and ZH18/20D□A.

### Ordering Example<sup>\*</sup>

ZH10DSA 4 products are clamped with L bracket.

① ZH10DSA-06-06-08N ..... 4 pcs.

② AS-10L ..... 2 pcs.

③ ZH2-TB104-A ..... 1 set (2 pcs. included)

\* The products are not assembled. M3: Assemble the products with 0.315 ± 0.03 N·m, M4: 0.76 ± 0.08 N·m.

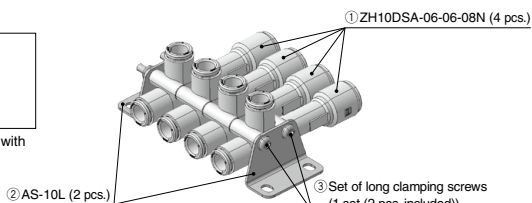

## Specifications



Body Ported

Operating temperature range	-5 to 50°C <sup>*1</sup>
Fluid	Air
Applicable tubing material	FEP, PFA, Nylon, Soft nylon, Polyurethane
Operating pressure range	0.1 to 0.6 MPa <sup>*2</sup>

\*1 No freezing

\*2 This is a supply pressure to supply (P) port. Vacuum (V) and exhaust (E) port should not be sealed simultaneously.

## Ejector Specifications<sup>\*1</sup>

Model	Nozzle nominal size [mm]	Vacuum pressure reached <sup>*2</sup> [kPa]		Maximum suction flow rate [L/min(ANR)]		Air consumption [L/min(ANR)]	Weight <sup>*3</sup> [g]
		Type S	Type L	Type S	Type L		
ZH05D□A	0.5	-90	-48	6	13	13	5.0
ZH07D□A	0.7			12	28	27	5.2
ZH10D□A	1.0			26	52	52	6.1
ZH13D□A	1.3		40	78	84	12.4	
ZH15D□A	1.5		58	78	113	13.4	
ZH18D□A	1.8		76	128	162	22.2	
ZH20D□A	2.0	-66		90	155	196	23.3

\*1 The values indicating characteristics are representative values, and may vary depending on the atmospheric pressure (weather, altitude, etc.).

\*2 Supply pressure: 0.45 MPa

\*3 Weight for the One-touch fitting type (Except standard bracket)

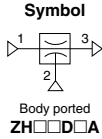

## Construction

### Body Ported

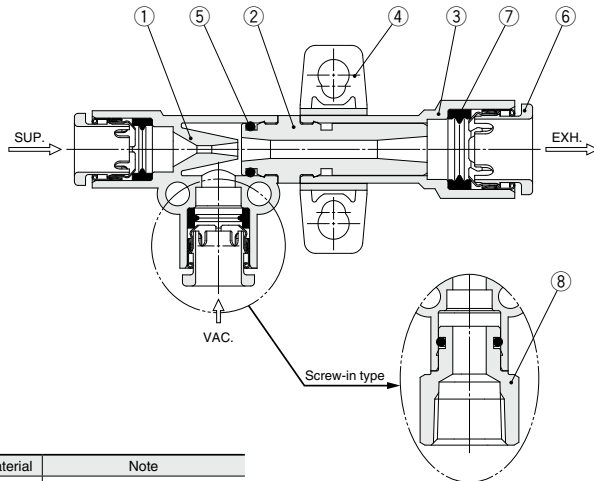

### Component Parts

No.	Description	Material	Note
1	Body	PBT	
2	Diffuser	PPS	Type S: Brown, Type L: Black
3	Adapter	PBT	
4	Standard bracket	PBT	Detachable (Accessory)
5	O-ring	NBR	Grease applied
6	Cassette	—	
7	Seal	NBR	Grease applied
8	Screw-in stud	Brass	Electroless nickel plating

ZK2  
ZQ  
ZR  
ZB  
ZA  
ZX  
ZM  
ZL  
ZH  
ZH  
ZH  
ZH  
ZHP  
ZU  
VQD-V

## Exhaust Characteristics / Flow Rate Characteristics (Representative value)

(Flow rate characteristics: Supply pressure: 0.45 MPa)

### ZH05□SA

#### Exhaust Characteristics

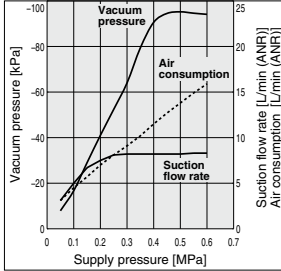

#### Flow Rate Characteristics

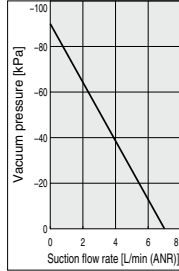

### ZH05□LA

#### Exhaust Characteristics

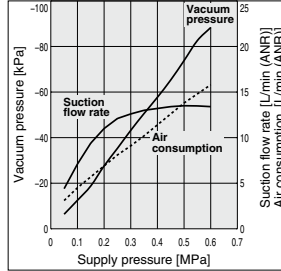

#### Flow Rate Characteristics

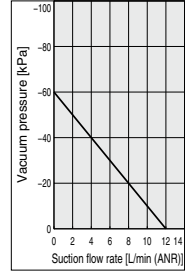

### ZH07□SA

#### Exhaust Characteristics

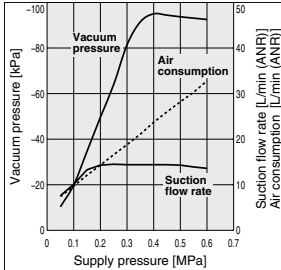

#### Flow Rate Characteristics

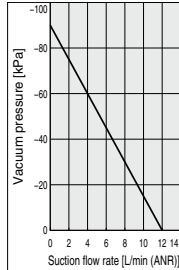

### ZH07□LA

#### Exhaust Characteristics

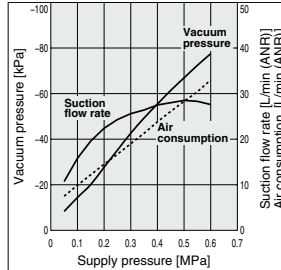

#### Flow Rate Characteristics

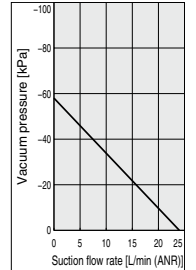

### ZH10□SA

#### Exhaust Characteristics

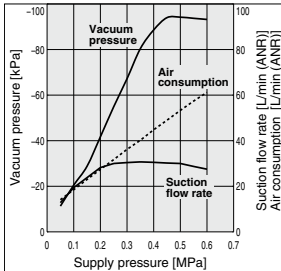

#### Flow Rate Characteristics

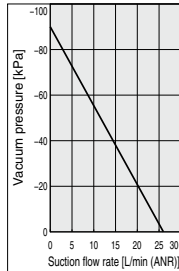

### ZH10□LA

#### Exhaust Characteristics

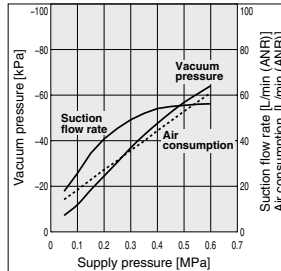

#### Flow Rate Characteristics

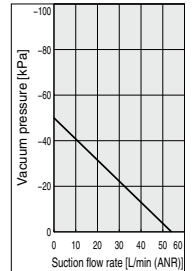

### ZH13□SA

#### Exhaust Characteristics

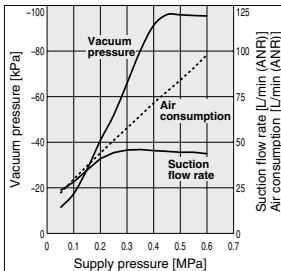

#### Flow Rate Characteristics

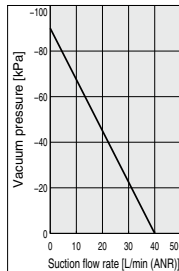

### ZH13□LA

#### Exhaust Characteristics

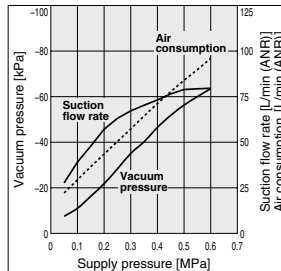

#### Flow Rate Characteristics

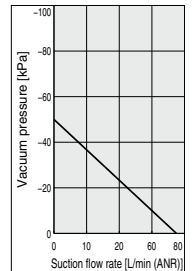

**Exhaust Characteristics / Flow Rate Characteristics (Representative value)**

(Flow rate characteristics: Supply pressure: 0.45 MPa)

**ZH15□SA**

**Exhaust Characteristics**

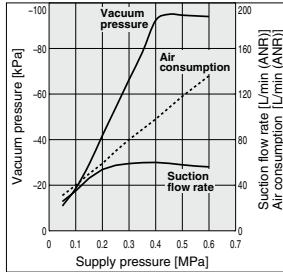

**Flow Rate Characteristics**

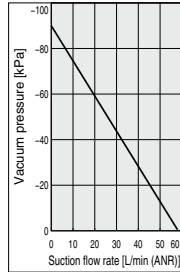

**ZH15□LA**

**Exhaust Characteristics**

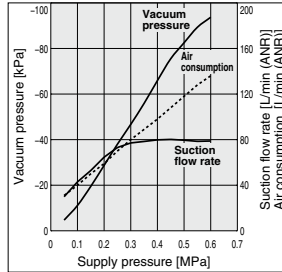

**Flow Rate Characteristics**

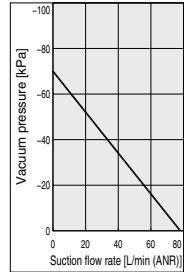

**ZH18□SA**

**Exhaust Characteristics**

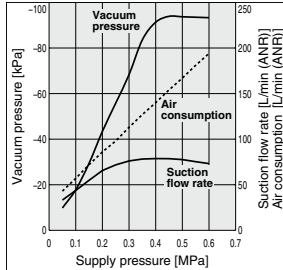

**Flow Rate Characteristics**

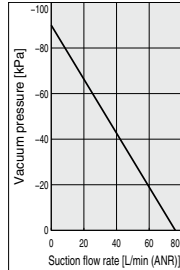

**ZH18□LA**

**Exhaust Characteristics**

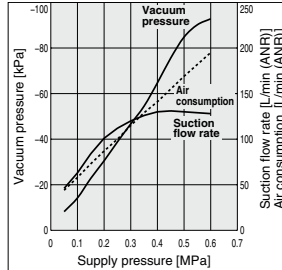

**Flow Rate Characteristics**

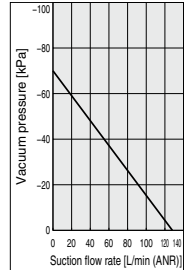

**ZH20□SA**

**Exhaust Characteristics**

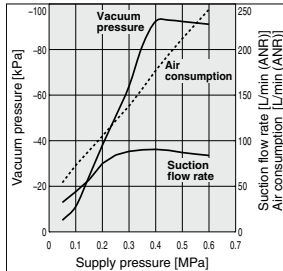

**Flow Rate Characteristics**

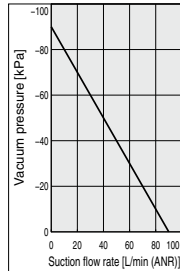

**ZH20□LA**

**Exhaust Characteristics**

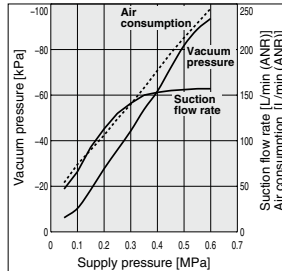

**Flow Rate Characteristics**

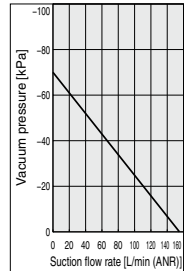

**How to Read Flow Rate Characteristics Graph**

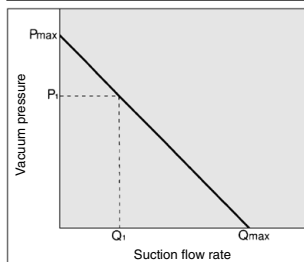

Flow rate characteristics are expressed in ejector vacuum pressure and suction flow. If suction flow changes, the vacuum pressure will also be changed. Normally this relationship is expressed in ejector standard operating pressure use. In graph, Pmax is maximum vacuum pressure and Qmax is maximum suction flow. The values are specified according to catalog use. Changes in vacuum pressure are expressed in the below order.

1. When ejector suction port is covered and made airtight, suction flow becomes zero and vacuum pressure is at maximum value (Pmax).
2. When suction port is opened gradually, air can flow through, (air leakage), suction flow increases, but vacuum pressure decreases. (condition P1 and Q1)

3. When suction port is opened further and fully opened, suction flow moves to maximum value (Qmax), but vacuum pressure is near zero (atmospheric pressure).

As described above, the vacuum pressure changes when the suction flow changes. In other words, when there is no leakage from the vacuum port, the vacuum pressure can reach its maximum, but as the amount of leakage increases, the vacuum pressure decreases. When the amount of leakage and the maximum suction flow become equal, the vacuum pressure becomes almost zero.

In the case when ventilative or leaky workpiece should be adsorbed, take note that vacuum pressure will not rise.

- ZK2
- ZQ
- ZR
- ZB
- ZA
- ZX
- ZM
- ZL
- ZH**
- ZH-X267
- ZHP
- ZU
- VQD-V

# ZH Series

## Body Ported: ZH05D<sup>S</sup>A-□-□-□ to ZH20D<sup>S</sup>A-□-□-□



### One-touch connection

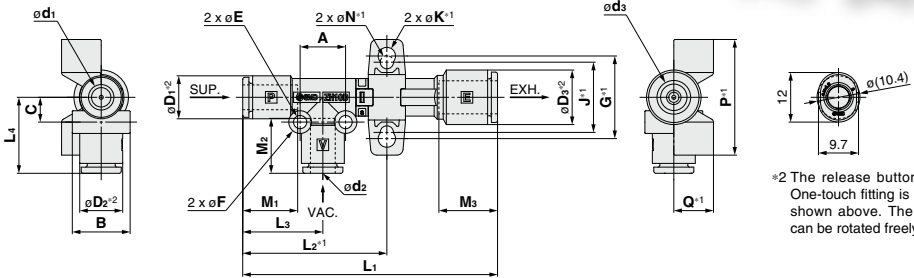

### All Ports: One-touch Fitting

	Model	D1	D2	D3	d1	d2	d3	M1	M2	M3	L1	L2 <sup>1</sup>	L3	L4	A	B	C	E	F	G <sup>1</sup>	J <sup>1</sup>	K <sup>1</sup>	N <sup>1</sup>	P <sup>1</sup>	Q <sup>1</sup>	
Metric	ZH05D <sup>S</sup> A-06-06-06										51.8															
	ZH07D <sup>S</sup> A-06-06-06	10.4	10.4	10.4	6	6	6	13.3	13.3	13.3	55	34.9	19.4	18.4	11	14	6	3.2	5.5	20	17			3.2	28	9.6
	ZH10D <sup>S</sup> A-06-06-08			13.2							8		14.2	61.7									4.2			
	ZH13D <sup>S</sup> A-08-10-10	13.2	15.9	15.9	8	10	10	14.2	15.6	15.6		71.8	43.9	22.4	24.4	17	20	9		7.8	27	22		4.2	35	12
	ZH15D <sup>S</sup> A-08-10-10											83.6	61.4													
Inch	ZH18D <sup>S</sup> A-10-12-12	15.9	18.5	18.5	10	12	12	15.6	17	17	105.7	60.9	28.4	26.4	22	22	10		8							
	ZH20D <sup>S</sup> A-10-12-12										112.2	62.2														
	ZH05D <sup>S</sup> A-07-07-07										51.8															
	ZH07D <sup>S</sup> A-07-07-07	11.15	11.15	11.15	1/4"	1/4"	1/4"	13.3	13.3	13.3	55	34.9	19.4	18.4	11	14	6	3.2	5.5	20	17			3.2	28	9.6
	ZH10D <sup>S</sup> A-07-07-09			13.2							5/16"		14.2	61.7									4.2			
	ZH13D <sup>S</sup> A-09-11-11	13.2	15.45	15.45	5/16"	3/8"	3/8"	14.2	15.6	15.6		71.8	43.9	22.4	24.4	17	20	9		7.8	27	22		4.2	35	12
	ZH15D <sup>S</sup> A-09-11-11											83.6	51.4													
ZH18D <sup>S</sup> A-11-13-13	15.45	19.3	19.3	3/8"	1/2"	1/2"	15.6	17	17	105.7	60.9	28.4	26.4	22	22	10		8								
ZH20D <sup>S</sup> A-11-13-13											112.2	62.2														

\*1 Dimensions when the standard bracket is mounted

## Body Ported: ZH20D<sup>S</sup>LA-□-□-□

### Standard bracket

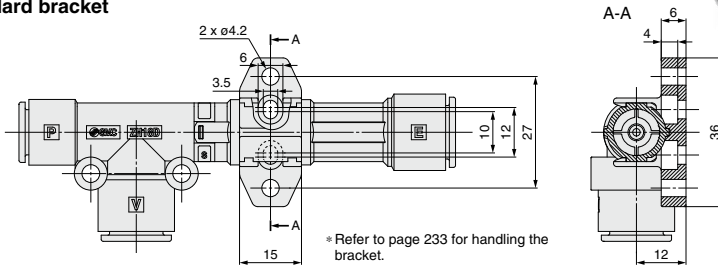

### Silencer

#### ZH05 to 15D<sup>S</sup>A

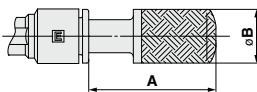

#### ZH18/20D<sup>S</sup>A-□-□-□-12

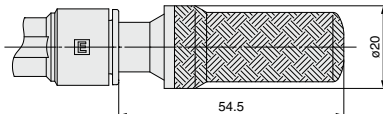

Model	A	øB
ZH05D <sup>S</sup> A-□-□-□-06/07	23.2	11
ZH07D <sup>S</sup> A-□-□-□-06/07		
ZH10D <sup>S</sup> A-□-□-□-08/09	30.8	13
ZH13D <sup>S</sup> A-□-□-□-10/11		
ZH15D <sup>S</sup> A-□-□-□-10/11	41.9	16.5

\* Directly mounted silencer not available for 1/2" EXH. port of ZH18/20D<sup>S</sup>A.

\* The standard bracket and silencer are not assembled with the product, but shipped together.



Body Ported: ZH05D<sup>S</sup>A-□-□-□ to ZH20D<sup>S</sup>A-□-□-□

One-touch and screw-in connection

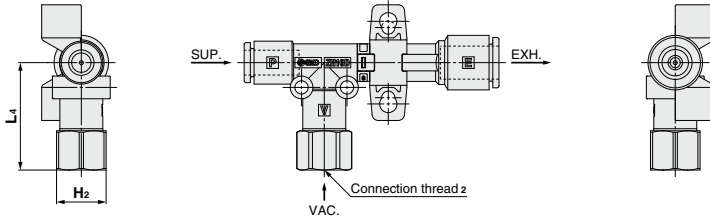

V Port: Screw-in  
P/E Port: One-touch Fitting

	Model	H <sub>2</sub>	L <sub>4</sub>	Connection thread 2
Metric	ZH05D□A-06-01-06	12	26	Rc1/8
	ZH07D□A-06-01-06			
	ZH10D□A-06-01-08			
	ZH13D□A-08-02-10	17	36.3	Rc1/4
	ZH15D□A-08-03-10			
	ZH18D□A-10-03-12	19	39.1	Rc3/8
ZH20D□A-10-04-12	24	44.1	Rc1/2	
Inch	ZH05D□A-07-N01-07	12.7	26	NPT1/8
	ZH07D□A-07-N01-07			
	ZH10D□A-07-N01-09			
	ZH13D□A-09-N02-11	17.46	36.3	NPT1/4
	ZH15D□A-09-N03-11			
	ZH18D□A-11-N03-13	22.23	39	NPT3/8
	ZH20D□A-11-N04-13	23.81	44.1	NPT1/2

Screw-in connection

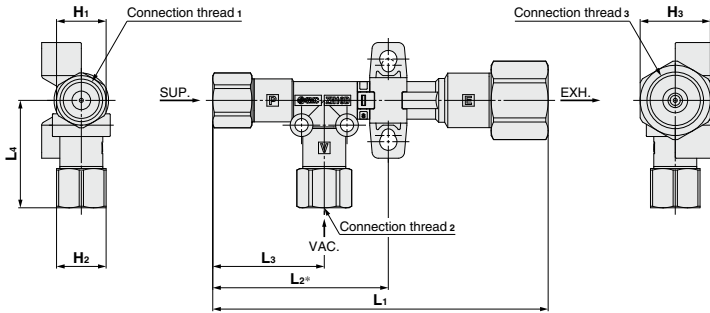

All Ports: Screw-in

	Model	H <sub>1</sub>	H <sub>2</sub>	H <sub>3</sub>	L <sub>1</sub>	L <sub>2</sub> *	L <sub>3</sub>	L <sub>4</sub>	Connection thread 1	Connection thread 2	Connection thread 3
Metric	ZH05D□A-01-01-01	12	12	12	67	42.5	27	26	Rc1/8	Rc1/8	Rc1/8
	ZH07D□A-01-01-01				70.2						
	ZH10D□A-01-01-01				76.4						
	ZH13D□A-01-02-02	17	17	17	90.8	51	29.5	36.3	Rc1/4	Rc1/4	Rc1/4
	ZH15D□A-02-03-03	17	19	19	108.2	63.3	34.3	37.1	Rc1/4	Rc3/8	Rc3/8
	ZH18D□A-03-03-03				131.1	73.6	41.1	39.1	Rc3/8	Rc1/2	Rc1/2
ZH20D□A-03-04-04	19	24	24	142.6	74.9	41.1	44.1	Rc3/8	Rc1/2	Rc1/2	
Inch	ZH05D□A-N01-N01-N01	12.7	12.7	12.7	67	42.5	27	26	NPT1/8	NPT1/8	NPT1/8
	ZH07D□A-N01-N01-N01				70.2						
	ZH10D□A-N01-N01-N01				76.4						
	ZH13D□A-N01-N02-N02	17.46	17.46	17.46	90.8	51	29.5	36.3	NPT1/4	NPT1/4	NPT1/4
	ZH15D□A-N02-N03-N03	17.46	22.23	22.23	108.2	63.3	34.3	37.1	NPT1/4	NPT3/8	NPT3/8
	ZH18D□A-N03-N03-N03				131	73.6	41.1	39	NPT3/8	NPT3/8	NPT3/8
	ZH20D□A-N03-N04-N04	22.23	23.81	23.81	142.6	74.9	41.1	44.1	NPT3/8	NPT1/2	NPT1/2

\* Dimensions when the standard bracket is mounted

- ZK2
- ZQ
- ZR
- ZB
- ZA
- ZX
- ZM
- ZL
- ZH**
- ZH
- ZH-X267
- ZHP
- ZU
- VQD-V

# ZH Series

## Body Ported: ZH05D□A-□-□-□ to ZH20D□A-□-□-□

### L-bracket (Bracket on a single side)\*

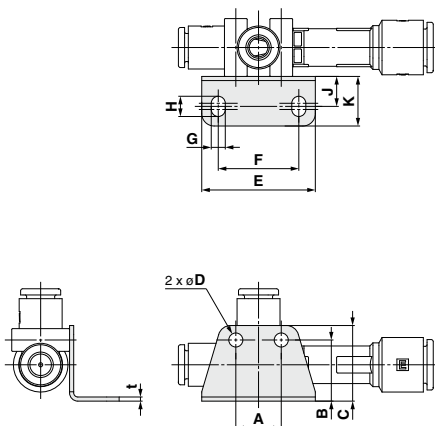

\* Long clamping screw set for 1 station required for assembly needs to be ordered separately. Refer to page 224.

### L-bracket (Brackets on both sides)\*

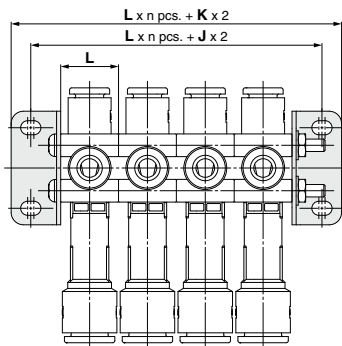

\* Long clamping screw set which is required for assembly needs to be ordered separately. Refer to page 224.

\* ZH15D□A-09-N03-11  
 ZH15D□A-N02-N03-N03  
 ZH18D□A-11-N03-13  
 ZH18D□A-N03-N03-N03  
 ZH20D□A-10-04-12  
 ZH20D□A-03-04-04  
 ZH20D□A-11-N04-13  
 ZH20D□A-N03-N04-N04

The above shown products cannot be mounted closely together, as width across flats of the screw-in connection will interfere with each other.

### L-Bracket (Brackets on Both Sides)

Part no.	Applicable model	A	B	C	D	E	F	G	H	J	K	L	t
AS-10L	ZH05/07/10D□A	11	14.8	18.3	3.4	27.5	19.5	3.4	4.9	7.3	12	14	1
AS-25L	ZH13/15D□A	17	19.6	24.6	4.5	38	28	4.5	6.5	9.5	15.5	20	1.2
AS-30L	ZH18/20D□A	22	24.8	29.8		43	33					22	1.4

**Body Ported: ZH05D<sup>S</sup>A-□-□-□ to ZH20D<sup>S</sup>A-□-□-□**

**DIN rail mounting bracket (Bracket on a single side)\***

ZH05 to 10D□A

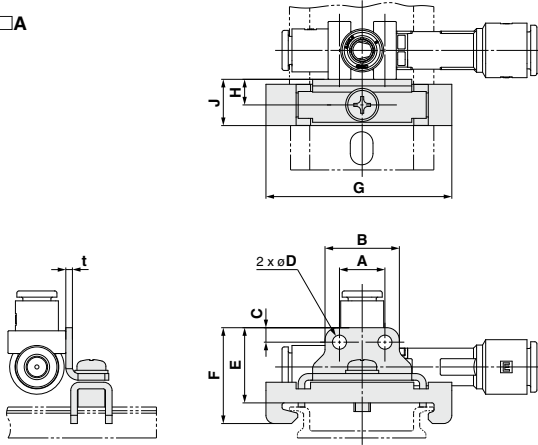

ZH13 to 20D□A

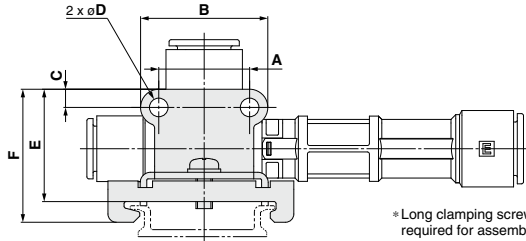

\*Long clamping screw set for 1 station required for assembly needs to be ordered separately. Refer to page 224.

**DIN rail mounting bracket (Brackets on both sides)\***

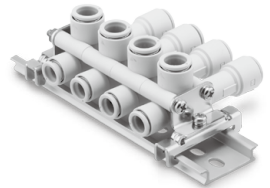
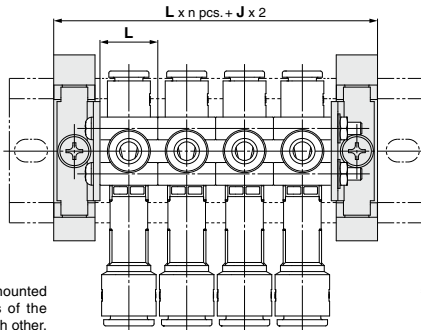

- \*ZH15D□A-09-N03-11
- ZH15D□A-N02-N03-N03
- ZH18D□A-11-N03-13
- ZH18D□A-N03-N03-N03
- ZH20D□A-10-04-12
- ZH20D□A-03-04-04
- ZH20D□A-11-N04-13
- ZH20D□A-N03-N04-N04

The above shown products cannot be mounted closely together, as width across flats of the screw-in connection will interfere with each other.

\*Long clamping screw set which is required for assembly needs to be ordered separately. Refer to page 224.

**DIN Rail Mounting Bracket (Brackets on Both Sides)**

Part no.	Applicable model	A	B	C	D	E	F	G	H	J	L	t
AS-10D	ZH05/07/10D□A	11	18	3.5	3.4	18.2	23.2	45	6.2	11.2	14	1.6
AS-25D	ZH13/15D□A	17	25.8	4.4	4.5	22	27				20	
AS-30D	ZH18/20D□A	22	30.8			27.2	32.2				22	

# ZH Series Circuit Examples

## ⚠ Caution

### Handling of Circuits

Select the related air preparation equipment with applicable size in reference to the circuit example below.

#### Ex. 1 Supply valve (2 port valve) + Suction filter

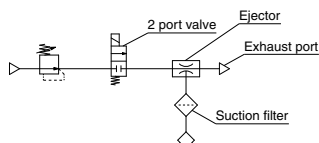

2 port valve is used to generate and stop the vacuum. Vacuum is released to the atmosphere. A suction filter is installed to protect the ejector.

#### Ex. 2 Supply valve (3 port valve) + Variable throttle + Suction filter

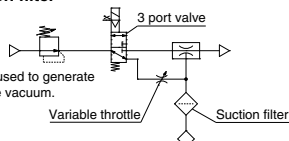

· 3 port valve is used to generate and release the vacuum.

3 port valve is used to generate and stop the vacuum (vacuum release is performed simultaneously). Variable throttle is installed for break flow adjustment. A suction filter is protecting the ejector.

#### Ex. 3 Supply valve (3 port valve) + Variable throttle + Suction filter + Silencer

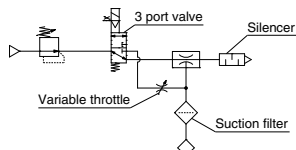

Power failure is prevented by changing the valve piping of Ex.2 and applying vacuum generation N.O. specification. Variable throttle and suction filters are installed. A silencer is mounted to the exhaust port (to reduce exhaust noise).

#### Ex. 4 Supply valve (2 port valve) + Release valve (2 port valve) + Variable throttle + Silencer + Suction filter + Pressure gauge

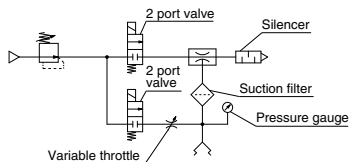

Vacuum generation and vacuum release are controlled by supply valve and release valve. A pressure gauge is installed to visually check the vacuum pressure during adsorption. The suction filter should be mounted to the location where the collected dust should not flow back due to release of air. (When using the 3 port valve, seal the R port of the release valve.)

#### Ex. 5 Supply/Release valve (5 port valve with 3-position) + Variable throttle

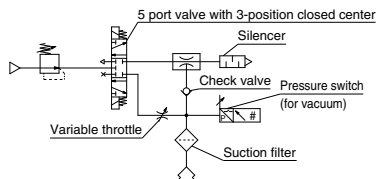

5 port valve with 3-position closed center is used to control the vacuum generation and release. A check valve is installed to the vacuum port to prevent vacuum pressure from being reduced when the supply valve is OFF. A pressure switch is installed in the vacuum circuit to detect pressure. A suction filter should be mounted to the position where the duct collected by release air can be flushed by released air.

\*The vacuum may leak depending on the check valve used. If a breathable workpiece is used, vacuum pressure is reduced rapidly. Sufficient verification is required before use.



# ZH Series Specific Product Precautions 1

Be sure to read this before handling the products.

Refer to back page 50 for Safety Instructions and pages 49 to 51 for Vacuum Equipment Precautions.

## Mounting

### ⚠ Caution

#### 1. Load to the ejector body

The body material is resin, therefore do not apply load to the port after mounting. Prevent the operation which generates moment, as it may cause performance reduction or damage to the body.

#### 2. Standard bracket

It is possible to mount and remove the standard bracket, which is included with this product (option without bracket can be selected). Do not excessively expand or bend the bracket as it may break. The appropriate tightening torque for the standard bracket is shown below.

For M3:  $0.315 \pm 0.03$  N·m

For M4:  $0.76 \pm 0.08$  N·m

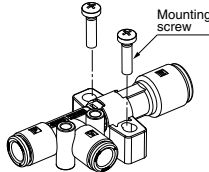

#### ● Mounting of standard bracket (ZH05 to 10D□A) and adjustment of vacuum (V) port

- 1) Align the recess of the bracket and protrusion of the adapter. Push the bracket from the top onto adapter (Fig.1).
- 2) Adjust the adapter to rotate the vacuum (V) port (Fig.2).

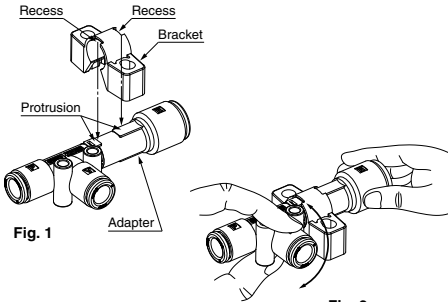
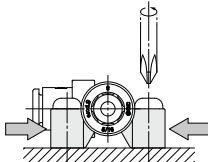

Fig. 1

Fig. 2

- 3) When mounting the product with a standard bracket, tighten the screw while holding both sides of the bracket. If the fit of the bracket is loose, the ejector may move after tightening the screws.



### ⚠ Caution

#### ● Mounting of standard bracket (ZH18/20D□A) and adjustment of vacuum (V) port

- 1) The standard bracket of ZH18/20D□A can be mounted either by using mounting holes 1 or 2 (Fig.3).
- 2) When mounting the product through mounting hole 1, mount the bracket to the installation position first (Fig.3).
- 3) To mount the product to the bracket, push it down while directing the narrow rib and E mark on the adapter upward and the wider rib to the side (Fig.4). Hold the adapter when rotating the vacuum (V) port for adjustment.
- 4) To remove the body from the bracket, unclip the fingers (2 pcs.) on one side outside and pull the ejector up while rotating the adapter. If the ejector is pulled up without unclipping the fingers, it may damage the bracket (Fig.5, 6). If an increased holding force is required, please contact your SMC sales representative.

#### Bracket for ZH18/20D□A

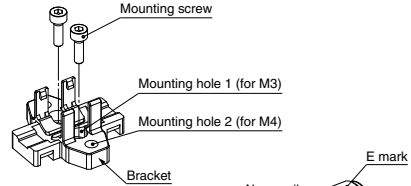

Fig. 3

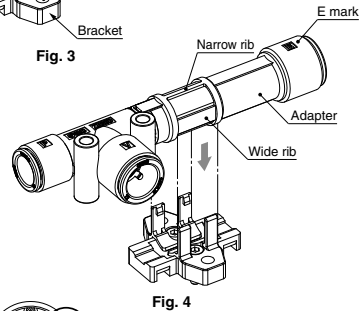

Fig. 4

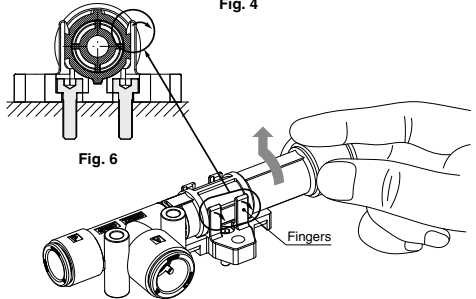

Fig. 5

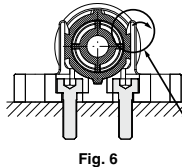

Fig. 6

ZK2

ZQ

ZR

ZB

ZA

ZX

ZM

ZL

ZH

ZH

ZH

-X267

ZHP

ZU

VQD-V



# ZH Series Specific Product Precautions 2

Be sure to read this before handling the products.

Refer to back page 50 for Safety Instructions and pages 49 to 51 for Vacuum Equipment Precautions.

## Mounting

### ⚠ Caution

#### ● Precautions for mounting with body mounting holes

If models listed below are intended to be mounted on a plane surface through the body mounting holes, the outside diameter of the screw-in stud will interfere with the mounting surface. Therefore, use a spacer with a thickness 1 or above.

Applicable model	t
ZH15D□A-09-N03-11 ZH15D□A-N02-N03-N03	2
ZH18D□A-11-N03-13 ZH18D□A-N03-N03-N03	1
ZH20D□A-10-04-12	
ZH20D□A-03-04-04	
ZH20D□A-11-N04-13 ZH20D□A-N03-N04-N04	

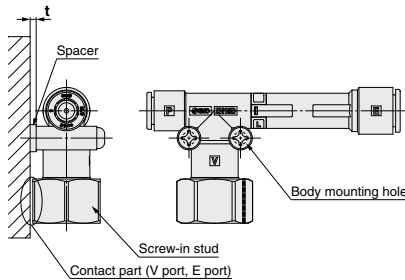

## Piping

### ⚠ Caution

#### 1. Piping diameter

The piping diameter for each port should be the standard size of One-touch fitting. If the piping diameter is reduced, it may lead to insufficient flow of supply air, reduction of suction flow and reduction in the vacuum pressure.

#### 2. Exhaust port piping

If there is any piping or silencer connected to the exhaust port, keep the back pressure at 5 kPa or less. Increased back pressure may lead to reduction of suction flow and delay in the transport cycle time. If a silencer is connected, the specified vacuum performance is reduced by 10% or less.

#### 3. One-touch fittings

Refer to the Fittings & Tubing Precautions in the Best Pneumatics No. 7 catalog for handling One-touch fittings.

#### 4. Piping to the female thread type

When mounting a fitting to the screw-in stud (female thread), hold the width across flats with an appropriate size wrench. If the load is applied to the resin body directly, it may damage the body.

## Model Selection

### ⚠ Caution

#### 1. Supply valve

Select the supply valve which can supply sufficient flow rate compared with the ejector air consumption. If the flow rate of the supply valve is insufficient, it may lead to vacuum failure. The selected supply valve should at least have the C factor below shown in the table blow.

#### Minimum C Factor of a Supply Valve

Model	C[dm <sup>3</sup> /(s·bar)]
ZH05□A	0.12
ZH07□A	0.23
ZH10□A	0.47
ZH13□A	0.80
ZH15□A	1.06
ZH18□A	1.53
ZH20□A	1.88

#### 2. Mounting of air equipment

If particles are sucked through the vacuum (V) port during workpiece adsorption, the vacuum performance might be reduced due to adhesion of particles to air passage of the product or clogging of the exhaust passage (silencer). It is recommended to install an air suction filter (ZFA, ZFB, ZFC series) in the middle of the piping on the vacuum side to prevent performance reduction. If air containing moisture is sucked, vacuum performance might also be reduced due to the same reason. In this case, install a drain separator for vacuum (AMJ series).

## Air Supply

### ⚠ Caution

#### 1. Quality of supply air

The recommendation for cleanliness of the compressed air supplied to the product is as specified in System No. C [Dry air] of Model Selection Guide of Air Preparation Equipment in the Best Pneumatics No. 6 catalog. This describes the impurity content in the compressed air based on the grade of compressed air quality 2.4.3, 2.5.3 and 2.6.3 of ISO8573-1: 2010 (JIS B8392-1: 2012)

If impurity enters the product, vacuum performance might be reduced due to deterioration of air passage and clogging of exhaust system.



# ZH Series Specific Product Precautions 3

Be sure to read this before handling the products.

Refer to back page 50 for Safety Instructions and pages 49 to 51 for Vacuum Equipment Precautions.

## Ejector Characteristics

### Caution

#### 1. Intermittent noise during vacuum generation

When the ejector standard supply pressure is close to the pressure that generates peak vacuum pressure, vacuum pressure may become unstable due to fluid vibration. If there is any operation failure or the intermittent noise needs to be reduced, increase or decrease the supply pressure. Avoid the supply pressure range where the vacuum pressure becomes unstable.

#### 2. Temperature reduction and vapor condensation during vacuum generation

When the ejector generates vacuum, compressed air expands adiabatically after passing through the nozzle. The temperature around the nozzle is reduced, so condensation might be generated on the product surface (the condensation dew point may vary depending on the temperature and relative humidity of the operating environment).

## When Ejector Operates

### Caution

#### 1. Exhaust air

If solid substances are sucked in through the vacuum (V) port, they will be discharged from the exhaust port with high speed, if the exhaust (EXH.) port is opened. Therefore, do not look into the exhaust port and direct the exhaust port toward a person when the ejector is operating. Therefore, do not look in at the exhaust port and direct the exhaust port to a person when the ejector is operating.

#### 2. Exhaust noise

Models with large nozzle diameter generate a large exhaust noise if the exhaust (EXH.) port is opened. Install a piping or silencer to the exhaust port to reduce the exhaust noise.

ZK2
ZQ
ZR
ZB
ZA
ZX
ZM
ZL
ZH
ZH
ZH -X267
ZHP
ZU
VQD-V