

Conforming to OSHA Standard Pressure Relief 3 Port Valve With Locking Holes

Series VHS20/30/40/50



Manually operated valve can be used to prevent accidents caused by residual pressure in pneumatic lines.



The supply/exhaust status of the air flow can be verified at a glance in the indicating window.

SUP: Supply
EXH: Exhaust

Can prevent accidents due to inadvertent air supply.

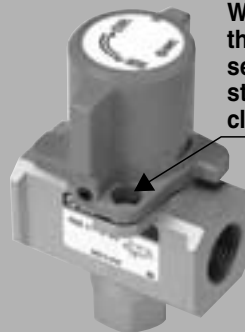

When in the exhaust position, the valve may be padlock secured. Prevents accidental start-ups while personnel are cleaning or servicing equipment.

OSHA standard (Occupational Safety and Health Administration Department of Labor)
For safety control, OSHA rule requires energy sources for certain equipment be turned off or disconnected and that the device either be locked or labelled with a warning tag.

- VM
- VMG
- VR
- VH

Combination with a modular style FRL is possible.

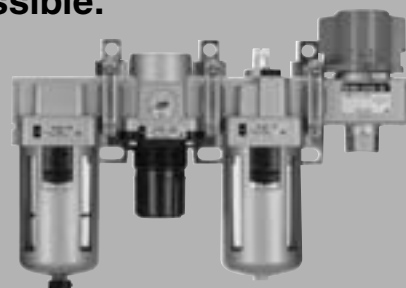
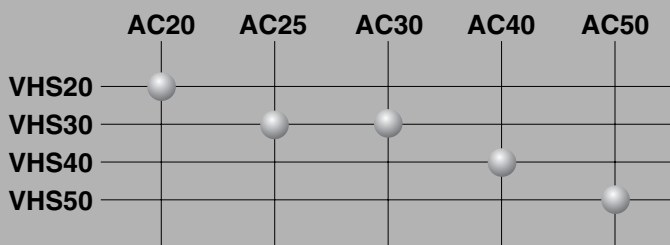

Conforming to OSHA Standard Pressure Relief 3 Port Valve With Locking Holes

Series VHS20/30/40/50

How to Order

VHS 30 - [] 03 - RZ - []

Pressure relief 3 port valve

Body size

Symbol	Standard port size
20	1/8
30	3/8
40	1/2
50	3/4

Thread type

Nil	Rc
N	NPT
F	G

Made to Order

Nil	Standard
X1	Body: Red
X502	Built-in silencer (EXH port)

Optional specifications

Symbol	Description
B	Knob color: Black
R	Flow direction: Right to left
Z ^{Note)}	PSI as unit displayed on label

Note) Only for the NPT thread.
Under the New Measurement Law,
products for overseas use only
(SI unit type for use in Japan).

Port size

Symbol	Port size	Body size			
		20	30	40	50
01	1/8	●	—	—	—
02	1/4	●	●	●	—
03	3/8	—	●	●	—
04	1/2	—	—	●	—
06	3/4	—	—	●	●
10	1	—	—	—	●

A spacer or spacer with bracket is required if the valve is combined with modular FRL.

Pressure relief 3 port valve	Spacer part no.	Spacer with bracket part no.	Applicable air preparation equipment
VHS20	Y200	Y200T	AC20
VHS30	Y300	Y300T	AC25, AC30
VHS40	Y400	Y400T	AC40
VHS40-06	Y500	Y500T	AC40-06
VHS50	Y600	Y600T	AC50, AC60 ^{Note)}

Note) Although connection to AC60 is possible, the flow rate may decrease due to the mounting position.

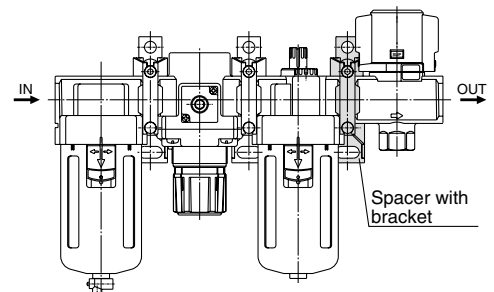



JIS Symbol

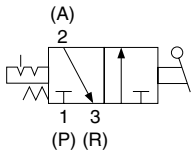

Specifications

Model		VHS20		VHS30		VHS40			VHS40-06	VHS50	
Piping port	IN, OUT	1/8	1/4	1/4	3/8	1/4	3/8	1/2	3/4	3/4	1
	EXH	1/8		1/4		3/8			1/2	1/2	
Cv	IN → OUT	0.54	0.76	0.87	1.68	1.46	2.06	2.98	4.17	4.44	6.78
	OUT → EXH	0.60	0.87	0.76	1.57	1.75	2.08	2.12	2.12	2.85	2.93
Fluid	Air										
Proof pressure	1.5 MPa										
Operating pressure range	0.1 to 1.0 MPa										
Ambient and fluid temperature	-5 to 60°C (No freezing)										
Handle switching angle	90°										
Paint color (Standard)	Handle ^{Note)} : Red, Body: Platinum silver										
Mass (kg)		0.19		0.25		0.35			0.42		0.77

Note) Knob color of black and body color of platinum silver are available as option (for the model number VHS□-□-B).

OSHA standard (Occupational Safety and Health Administration Department of Labor)

For safety control, OSHA rule requires energy sources for certain equipment be turned off or disconnected and that the device either be locked or labelled with a warning tag.

Construction

VHS20/30

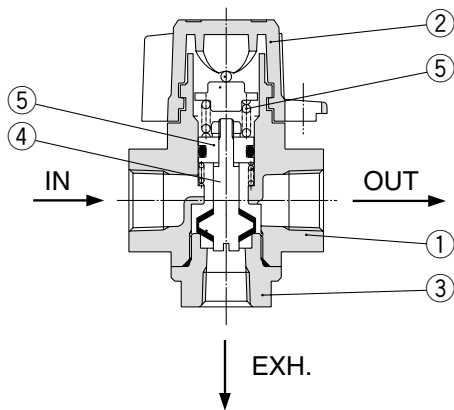

VHS40/40-06/50

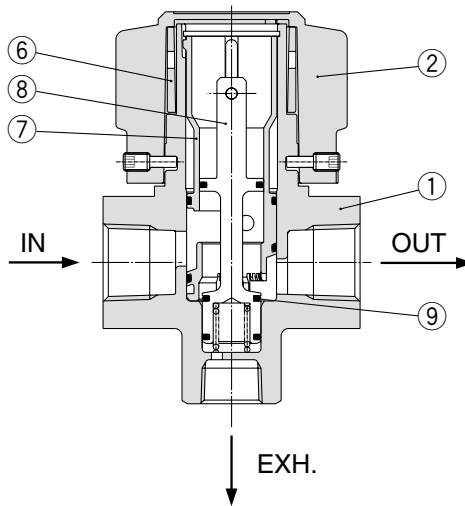

Component Parts

No.	Description	Material			Note
		VHS20	VHS30	VHS40(-06), 50	
①	Body	Zinc die-casted	Aluminum die-casted	Aluminum die-casted	Platinum silver coated
②	Handle	Zinc die-casted		Aluminum die-casted	Red coated
③	Valve guide	Zinc die-casted			—
④	Valve	Aluminum alloy + HNBR			—
⑤	Piston	Brass			—
⑥	Cam ring	—	—	Zinc die-casted	—
⑦	Ferrule	—	—	POM	—
⑧	Spool	—	—	Brass	Electroless nickel plated
⑨	Seal	—	—	HNBR	—

The VHS series cannot be disassembled. Parts cannot be shipped separately.

- VM□
- VMG
- VR□
- VH□

Series VHS20/30/40/50

Dimensions

VHS20/30

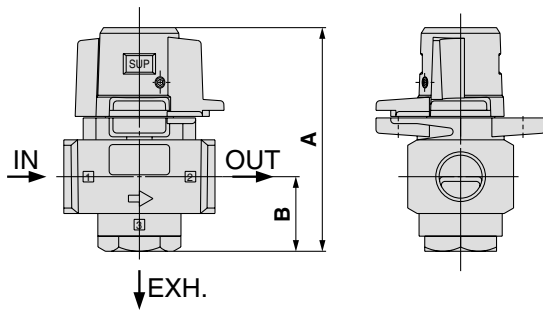
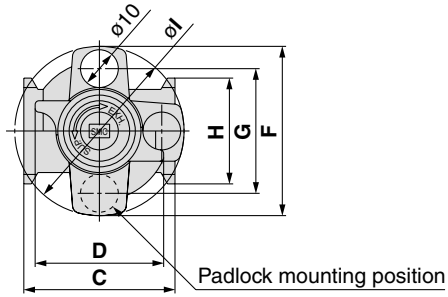

VHS40/40-06/50

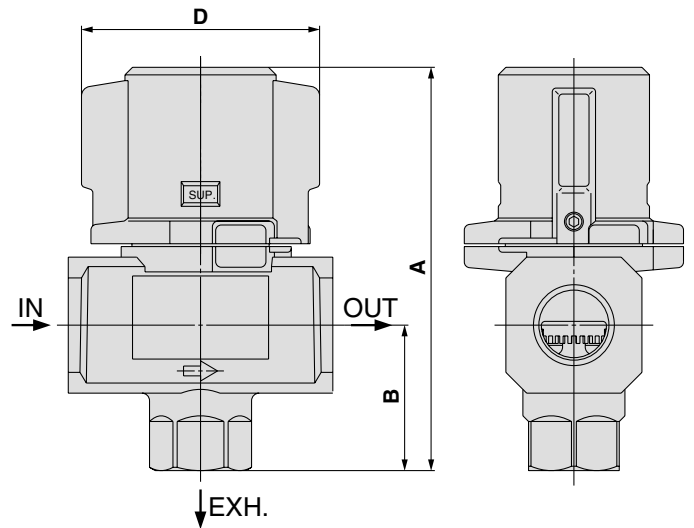
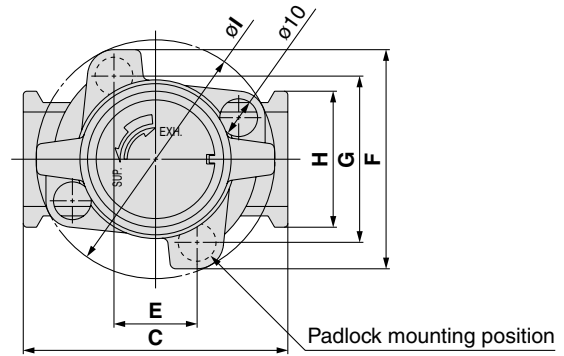

Model	Piping port	A	B	C	D	E	F	G	H	I
VHS20	1/8, 1/4	59	20	40	34	—	45	33	28	45
VHS30	1/4, 3/8	78	29	53	46	—	55	42	30	55
VHS40	1/4, 3/8, 1/2	107	39	70	63	22	58	44	36	63
VHS40-06	3/4	110	42	75	67	21	65	50	44	69
VHS50	3/4, 1	134	53	90	78	26	76	61	54	81



Series VHS20/30/40/50

Specific Product Precautions

Be sure to read before handling.

Refer to front matters 58 and 59 for Safety Instructions and pages 3 to 7 for 3/4/5 Port Solenoid Valve Precautions.

Precautions on Design

Warning

1. Please consult with SMC in cases where the ambient environment does not permit leakage or if fluid other than air is used.
2. When exhaust piping is connected to the exhaust port (3), select a model with an effective sectional area not smaller than that in the table below.

Model	Effective sectional area (mm ²) (Cv)
VHS20	5 (0.27)
VHS30	5 (0.27)

3. Do not apply negative pressure. It may result in malfunction.

Selection

Warning

1. In some cases, mineral oil grease used for internal parts and sealant may be carried to the output side. Please contact SMC if this causes any inconvenience in use.

Installation and Adjustment

Warning

1. Confirm the symbols "1" and "2" before the valve is connected. The port marked "1" is the air inlet and the port marked "2" is the outlet. Pressurization is only possible via the inlet port (1). Reverse connection may cause malfunction. The port symbols and corresponding piping types are shown in the table below:

Port symbol	Piping type
1	Inlet
2	Outlet
3	Exhaust

Caution

1. The valve must be switched to each position instantly and securely. Stopping the knob between the extreme positions may cause malfunction.
2. Do not remove the mounting screws from the knob. As this may cause malfunction.

Piping

Warning

1. Before piping is connected, the pipes should be thoroughly blown through with air (flushing) or washed to remove chips, cutting oil and other debris from inside. Should they remain, they could cause malfunction.
2. When connecting pipes and fittings, etc., be sure that neither chips from the pipe threads nor sealing material get inside the valve. When using sealant tape, leave 1.5 to 2 thread ridges exposed at the end of the pipe/fitting.
3. When screwing a piping component into the valve, secure the female threaded side and apply the recommended tightening torque. Under tightening may result in loosening or sealing failure while over tightening may cause damage to threads and other problems.

Recommended tightening torque

Unit: N·m

Connection thread	1/8	1/4	3/8	1/2	3/4	1
Torque	7 to 9	12 to 14	22 to 24	28 to 30	28 to 30	36 to 38

Air Supply

Warning

1. Use clean air. Do not use compressed air which contains chemicals, synthetic oils containing organic solvents, salts or corrosive gases, etc., as this can cause damage or malfunction.
2. Install an air dryer or after cooler on the upstream side of the pressure release 3 port valve because air containing excessive drainage may cause malfunction.

Caution

1. Install an air filter of 5 μm filtration on the inlet side.
2. Install a mist separator on the inlet side to remove carbon powder from the compressor or other equipment. An excessive amount of carbon dust ingress via the inlet may cause the valve to malfunction.

Refer to SMC's "Air Cleaning Equipment" catalog for further details on compressed air quality.

Operating Environment

Warning

1. Do not use valves where there is direct contact with, or in atmospheres of, corrosive gases, chemicals, salt water, water or steam.
2. Do not use in an explosive atmosphere.
3. Do not use in locations subject to vibration or impact. Confirm the specifications for each series.
4. A protective cover should be used to shield valves from direct sunlight.
5. Shield valves from radiated heat generated by nearby heat sources.
6. Employ suitable protective measures in locations where there is contact with water droplets, oil, or welding spatter.
7. Install a silencer into port (3) to prevent the ingress of dust if there is a lot of dust in the atmosphere. If dust enters the valve via port (3), it may cause air leakage.

Maintenance

Warning

1. Perform maintenance procedures as shown in the instruction manual. If handled improperly, malfunction or damage of machinery or equipment may occur.
2. Do not disassemble the product. Improper handling will cause malfunction or breakage of the machinery or equipment.
3. When equipment is to be removed, first confirm that measures are in place to prevent dropping of driven objects and run-away of equipment, etc. Then cut the supply air pressure and electric power, and exhaust all compressed air from the system using its residual pressure release function. When the equipment is to be started again after remounting or replacement, first confirm that measures are in place to prevent lurching of actuators and then confirm that equipment operates normally.

Caution

1. Once a lubricant is introduced, be sure to continue lubrication. If it is discontinued, malfunction may result due to loss of the initial lubricant. Apply class 1 turbine oil (ISO VG32) as a lubricant. Use of other lubricants may cause malfunction.

VM□

VMG

VR□

VH□