

ORDER  
ONLINE

AUTOMATION – CONTROL VALVES – COMPONENTS  
FOR PROCESS CONTROL

# WERSA<sup>®</sup>

BULLETIN  
B316-2004

ISO 9001



CERTIFIED

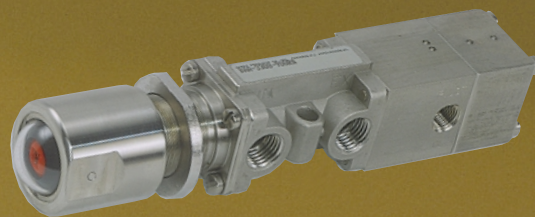
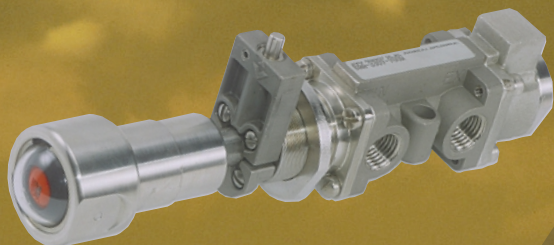

ORDER  
ONLINE

Versa exercises diligence to assure that information contained in this catalog is correct, but does not accept responsibility for any errors or omissions. Versa also reserves the right to change or delete data or products at any time without prior notification. To be sure the data you require is correct, consult factory.

**THIS CATALOG SERIES B 316 (Three-way Valves)  
COVERS . . . 550 (Indicating Relay Valves)  
and 900 (Main Supply Reset & Indicating Relay Valves)  
Manual Shut-Off Valves**

**CONTENTS GUIDE**

**Series B316 Three-Way Valves (3/2) . . . . .Page 4-14**

**General Description**

The B316 Series is a complete line of compact, rugged Three-Way (3/2), side-ported valves, constructed of 316 stainless steel (conforms to NACE standard MR-01-75). They are designed for use particularly in corrosive environments and to control a variety of aggressive media as well as air. O ring packed poppets provide bubbletight sealing throughout the operating pressure range and when used to operate small volume appliances this feature conserves valuable instrument air.

Actuations include solenoid/pilot (including those suitable for Ordinary, Hazardous or LOW-WATT service ), remote pressure pilot, manual, and mechanical. Many combination actuators and special function types can also be provided. Consult the factory for these items.

Solenoid actuated valves can be 2-position, single or double solenoid. A manual override option is available for most types.

Remote pressure pilot models can be 2-position, single or double pilot.

Manually actuated valves are 2-position, push button panel mounting types and are offered with or without guarded pushbuttons. An optional lid knob operated type is also available.

Mechanically actuated valves are 2-position and are supplied with a roller for cam interface.

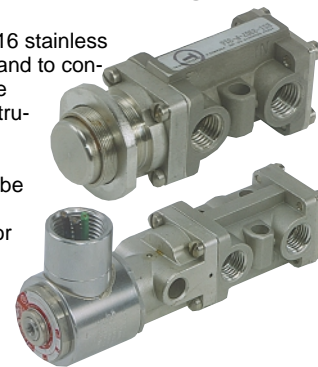

**Series B900 Main Supply Reset & Indicating Relay Valves . . . . .Page 16-21**

**General Description**

The B900 Series is comprised of Three-Way (3/2) Manual/Pilot Operated Main Supply Reset valves and Three-Way (3/2) Indicating Relay valves. All are constructed of 316 stainless steel (meets NACE standard MR-01-75). They are designed for use particularly in corrosive environments and to control aggressive media as well as air. O ring packed poppets provide bubbletight sealing throughout the operating range and when used to operate small volume appliances this feature saves valuable instrument air.

Main Supply Reset valves can function as master relay valves and are generally pilot operated-spring return, 2-position valves that are provided additionally with a means of manual operation. The function of the Main Supply Reset valve is to control the supply of pressure to a system or portion of a system. If a problem is sensed at some point in the system, the Main Supply Reset valve will shift to dump system pressure from that portion of the circuit controlled by that Main Supply Reset valve. The shifting of the Main Supply Reset valve is accomplished by a pilot device which is an integral part of the valve. The pilot is pressurized when the system is running normally, but when a problem is sensed, the pilot is depressurized and the valve shuts off the pressure to the main system or that portion of the main system that the valve controls. Several variations of reset are available. One example is a "latching pilot" whereby when pilot pressure returns, the valve will not shift to open the supply to the main system until the valve is manually reset. The manual portion of the reset can also be latching or non-latching. Most Main Supply Reset valves can also be equipped with an integral visual indicator that indicates when pressure is present in the pilot chamber. Complete functional descriptions of each valve can be found on the pages within this valve series.

Indicating Relay valves are of the First Out-Receiving or First Out-Transmitting type. They have two functions generally. First, to indicate visually on a panel that a circuit malfunction has occurred and secondly, to quickly exhaust operating pressure from the system through the Main Supply Reset valve.

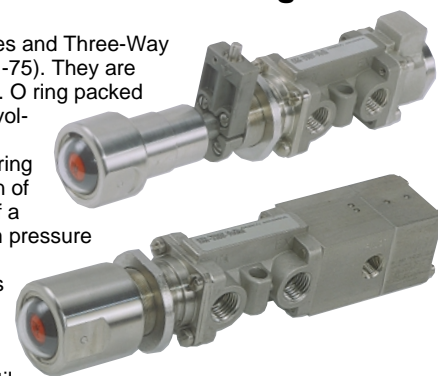

**Series B550 Indicating Relay Valves . . . . .Page 21-22**

**General Description**

The B550 Series Indicating Relay valves are Three-Way (3/2) First Out Indicating valves. They are of the First Out-Receiving type, First Out-Transmitting type or First Out-Bypass type. All are constructed of hard coated aluminum (MIL-A-8625E, Type III, Class 1) to provide reasonable resistance to extreme environmental conditions. Bubbletight sealing, accomplished by employing wafer seals, conserves valuable instrument air throughout the operating pressure range.

First out Indicating Relay valves have two functions. First, to indicate visually on a panel that a circuit malfunction has occurred and secondly, to quickly exhaust operating pressure from the system through the Main Supply Reset valve. The Indicating Relay valve with the Bypass function additionally provides the means to bypass the specific malfunctioning circuit without shutting down associated circuits.

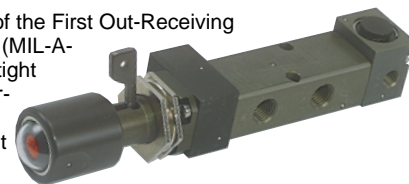

**Manual Shut-Off Valves . . . . .Page 15**

**General Description**

For emergency shut down systems a Two-Way Manual Bleed valve and a Three-Way Manual Block & Bleed valve are available. Both valves are constructed of 316 stainless steel (meets NACE standard MR-01-75), and may be used as panic valves to quickly depressurize the system in order to get immediate shut down.

The Two-Way Manual Bleed valve is closed during normal operation, but manual actuation or backpressure to the outlet port will dump system pressure to atmosphere.

The Three-Way Manual Block & Bleed valve connects the inlet to the outlet during normal operation. Manual actuation or backpressure to the exhaust port causes the inlet to be blocked while the outlet dumps system pressure to atmosphere.





# SERIES B316 VALVES

STAINLESS STEEL CONSTRUCTION

## 3-WAY VALVES

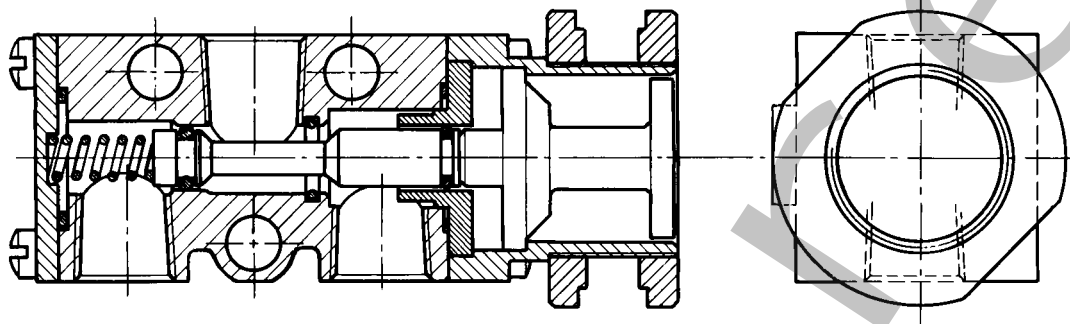

### Construction

Versa B316 Valves are spool poppet valves except for double pilot and double solenoid valves which have balanced spools. Standard size O ring seals, placed in accordance with Versa's Anti-Extrusion principle provides long trouble free service with little and easy maintenance.

### Materials

- Valve body and actuating caps: 316 stainless steel
- All internal wetted metal parts: 316 stainless steel NACE approved materials (solenoid parts not NACE approved)
- Valve Seals: FKM (fluorocarbon) O ring seals used as standard
- Screws: stainless steel

### Porting and Flow

- Valve ports are 1/4 NPT; Pilot and solenoid ports are 1/8 NPT
- Flow area (orifice) is 0.196" (5mm)
- $C_v$  ( $K_v$ ) normally closed = 1.6 (23.2); normally open = 1.1 (16.0)

### Pressure and Media

- 0 to 200 psig (14 bar); Air or Hydrocarbon gases or other gases compatible with materials used.
- Pressures for Pilot, or Solenoid/Pilot, or Manual & Pilot Combination operated valves - see pages pertaining to specific valve.

### Electrical

See pages 8 to 14

### Temperature Range

Solenoid Valves: The table below lists suggested suffix options for various temperature ranges and/or types of service. For temperatures or conditions not listed, consult factory.

Manual, Mechanical, Pilot Valves: -10°F (-23°C) to 200°F (95°C).

| Temperature Range<br>(Medium/Ambient<br>Temperature) | TYPE OF SERVICE           |  |                         |  |               |   |
|--|---------------------------|--|-------------------------|--|---------------|---|
|  | Intermittent Duty Service |  | Continuous Duty Service |  |               |   |
|  | AC or DC                  |  | AC                      |  | DC            |   |
|  | Coil                      | Solenoid Plunger*  | Coil                    | Solenoid Plunger*  | Coil          | Solenoid Plunger*   |
| 150°F to 200°F<br>(65°C) (95°C)                      | Suffix<br>-HT             | Suffix-3 (may be<br>inclusive in other<br>suffix options as it is<br>in -HT) | Suffix<br>-HT           | Suffix-3 (may be<br>inclusive in other<br>suffix options as it is<br>in -HT) | Suffix<br>-HT | Suffix-3 (may be<br>inclusive in other<br>suffix options as it is<br>in -HT)  |
| 120°F to 150°F<br>(50°C) (65°C)                      | Standard                  | Suffix-3 (may be<br>inclusive in other<br>suffix options)                    | Standard                | Suffix -3 (may be<br>inclusive in other<br>suffix options)                   | Suffix<br>-HT | Suffix -3 (may be<br>inclusive in other<br>suffix options as it is<br>in -HT) |
| -10°F to 120°F<br>(-23°C) (50°C)                     | Standard                  | Standard   | Standard                | Suffix -3 (may be<br>inclusive in other<br>suffix options)                   | Standard      | Suffix -3 (may be<br>inclusive in other<br>suffix options)                    |

\* All solenoids for hazardous locations include suffix -3 as standard.

### Installation, Filtration & Lubrication

Valves have no limitations on mounting orientation.

40-50 micron filtration recommended.

General purpose lubricating oil ISO, ASTM viscosity grade 32 recommended.

# Manually Operated Valves

For palm, finger, knee or straight-line mechanical operation. Can also be cam actuated if cam rise is gradual. Unguarded type has button exposed above valve body approximately 1/8", which is distance required for full actuation. Guarded type has

button flush with the button guard to protect against accidental actuation. Nominal operating force is 3.75 lbs. + .05 times line pressure (or 3.25N x bar line pressure + 17N).

Dimensions:  $\frac{\text{Inch}}{\text{mm}}$

## 3/2 (Three-Way) Valve

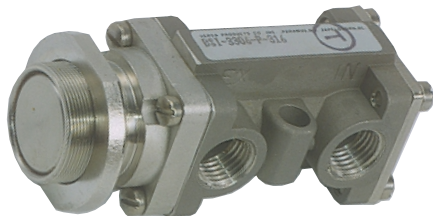

### Button Operated (Guarded)/ Spring Return

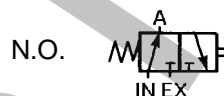
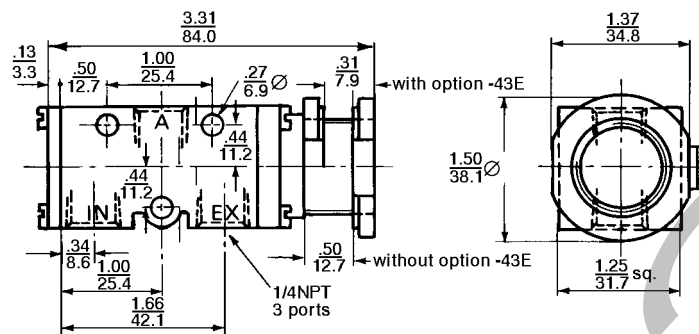

BSI-3306-P-316



BSI-3303-P-316 (closed crossover)  
BSI-3308-P-316

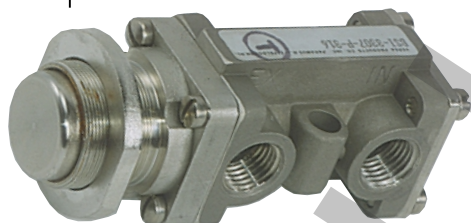

### Button Operated (Unguarded)/ Spring Return

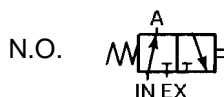
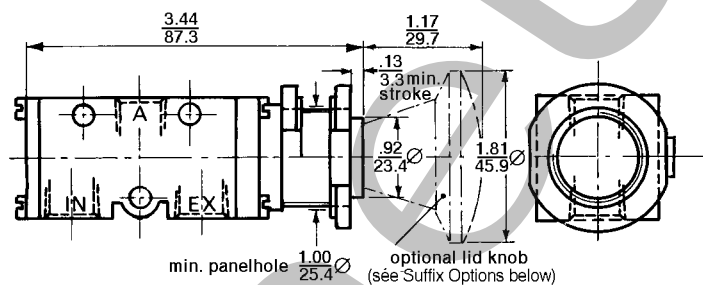

BSI-3307-P-316

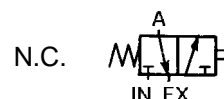

BSI-3309-P-316

#### Suffix Options:

- 43E Additional panel mount nut for flush front mounting
- S Strong spring for applications with marginal lubrication; use requires 45% additional force to operate.

- S-25B Black plastic lid knob
- S-25G Green plastic lid knob
- S-25R Red plastic lid knob

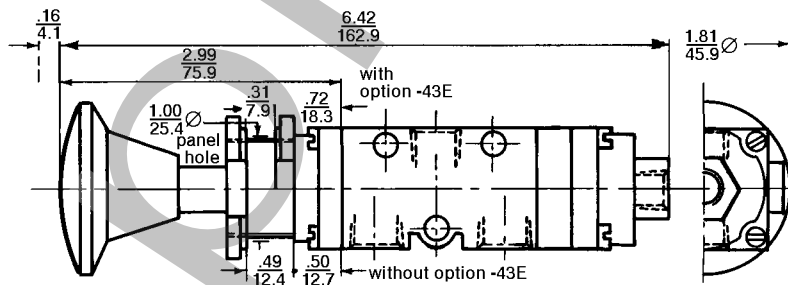

### Palm Button Operated/ Pilot Return\*



BIP-3303-316 (closed crossover)  
BIP-3309-316

\*Pilot pressure req. 15-200 psi (1-14 bar)

#### Suffix Options:

- 43E Additional panel mount nut for flush front mounting

- S-25B Black plastic lid knob
- S-25G Green plastic lid knob
- S-25R Red plastic lid knob

# SERIES B316 VALVES

STAINLESS STEEL CONSTRUCTION

## Pilot Operated Valves

Controlled by a pressure signal applied to a small integral pilot piston that actuates the valve.

Pilot medium can be other than medium being controlled.

### 3/2 (Three-Way) Valve

Dimensions:  $\frac{\text{Inch}}{\text{mm}}$

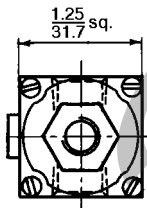
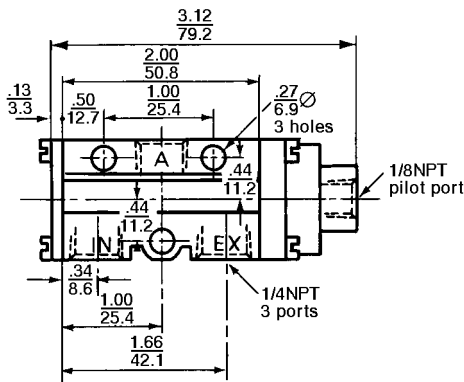
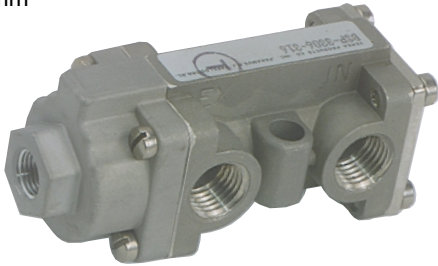

Pilot Operated/Spring Return

BSP-3306-316

BSP-3303-316 (closed crossover)

BSP-3308-316



**Pilot Operated Spring Return**

**Controlled (inlet) Pressure**

|  | psi  | bar   | psi | bar | psi | bar | psi | bar | psi | bar | psi | bar | psi | bar  | psi | bar | psi | bar  | psi | bar |
|--|------|-------|-----|-----|-----|-----|-----|-----|-----|-----|-----|-----|-----|------|-----|-----|-----|------|-----|-----|
|  | 0-20 | 0-1.5 | 40  | 3   | 60  | 4.1 | 80  | 5.5 | 100 | 6.8 | 120 | 8.2 | 140 | 10   | 160 | 11  | 180 | 12.5 | 200 | 14  |
| <b>Minimum pilot pressure required</b> | 18   | 1.25  | 20  | 1.4 | 22  | 1.5 | 24  | 1.7 | 26  | 1.8 | 28  | 2.0 | 30  | 2.15 | 32  | 2.3 | 34  | 2.5  | 36  | 2.5 |

Pilot Operated/Pilot Return; (detented)

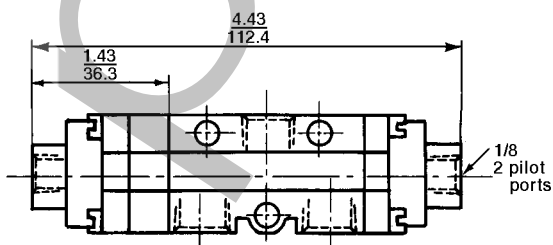
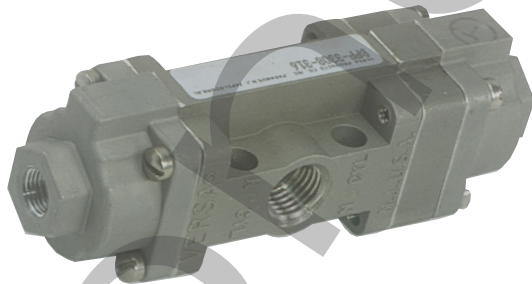

**Pilot Operated Pilot Return (detented)**

**Controlled (Inlet) Pressure**

| <b>Pilot Pressure Required</b> | psi    | bar  |
|--------------------------------|--------|------|
|                                | 0-200  | 0-14 |
|                                | 15-200 | 1-14 |

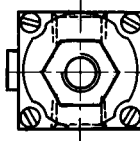

BPP-3308-316

# Mechanically Operated Valves

## 3/2 (Three-Way) Valves



Can be operated by a cam or machine member from any angle, but pressure angle should not exceed 15° from vertical center line.

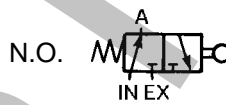
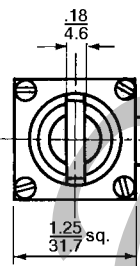
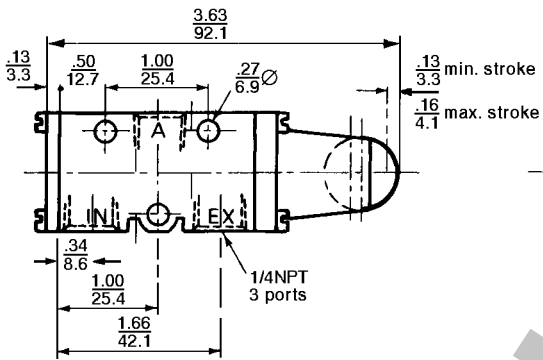

Cam operated/  
Spring Return

BSC-3306-316



BSC-3303-316 (closed crossover)  
BSC-3308-316

# SERIES B316 VALVES

STAINLESS STEEL CONSTRUCTION

## Solenoid/Pilot Operated Valves– 3/2 (Three-Way) Valves

Solenoid-Pilot actuated Series B316 valves are available with a variety of different solenoids for both nonhazardous and hazardous locations. Basic details of actuators are listed below. For additional data consult factory.

### Nonhazardous Location Solenoids

| Solenoid Identification Detail | Protection Classification | Area Classification and (Gas Grouping) | Certification (Conformance) | Ingress Protection |
|--------------------------------|---------------------------|--|-----------------------------|--------------------|
| None<br>(page 10 & 11)         | General Purpose           | Indoor & Outdoor                       | CSA                         | NEMA 1, 2, 3       |

### Hazardous Location Solenoids

| Solenoid Identification Detail                                  | Protection Classification                 | Area Classification and (Gas Grouping)  | Certification (Conformance) | Ingress Protection |
|---|---|---|-----------------------------|--------------------|
| -XX<br>(page 12)  | Hazardous Locations                       | Class I, Division 2 (A&B)<br>Class I, Division 1 (C&D)<br>Class II, Division 1 (E, F, &G) | UL<br>CSA                   | NEMA 7 & 9         |
| -LB-XX<br>(page 12)   | Hazardous Locations                       | Class I, Division 2 (A&B)<br>Class I, Division 1 (C&D)<br>Class II, Division 1 (E, F, &G) | UL<br>CSA                   | NEMA 7 & 9         |
| -XN<br>(page 12)  | (d) Flameproof                            | Zones 1 & 2<br>(IIB+H2) Category 2G<br>T4   | ATEX                        | IP66               |
| -LB-XN<br>(page 12)   | (d) Flameproof                            | Zones 1 & 2<br>(IIB+H2) Category 2G<br>T6   | ATEX                        | IP66               |
| -XDAS<br>or<br>-XDAT<br>(page 13)                               | (d) Flameproof                            | Zones 1 & 2<br>(IIC) Category 2G  | ATEX                        | IP66 & IP67        |
| -XMAA<br>or<br>-XMAE<br>or<br>-XMAF<br>or<br>-XMAG<br>(page 13) | (m) Encapsulation<br>(e) Increased Safety | Zones 1 & 2<br>(II) Category 2G   | ATEX                        | IP66 & IP67        |
| -XMFA<br>or<br>-XMFE<br>or<br>-XMFF<br>or<br>-XMFG<br>(page 13) | (m) Encapsulation<br>(e) Increased Safety | Zones 1 & 2<br>(II) Category 2G   | ATEX                        | IP66 & IP67        |
| -HC-XISC<br>-HCC-XISC<br>(page 14)                              | Hazardous Locations                       | Class I, Groups (A, B, C & D)<br>Class II, Groups (E, F, &G)<br>Class III, Division 1     | Factory Mutual<br>CSA       | NEMA 4             |
| -HC-XISX6<br>-HCC-XISX6<br>(page 14)                            | (ia) Intrinsic Safe                       | Zones 0, 1 and 2<br>(IIC) Category 1G<br><br>T6   | ATEX                        | IP65               |
| -XIFA<br>or<br>-XIFE<br>or<br>-XIFF<br>(page 14)                | (ib) Intrinsic Safe                       | Zones 1 & 2<br>(IIB) Category 1G  | ATEX                        | IP66 & IP67        |

**PRODUCT NUMBER COIL CODES:** Complete product numbers require, when applicable, a coil code that represents the desired coil current, frequency and voltage. The coil code takes the form shown below, with ratings and voltage substituted as required:

**Rating Code**  **###** **Voltage**

A= 60Hz frequency (indicated by three digits;  
D= Direct Current (DC) as example, 24 volts = 024,  
E= 50 Hz frequency 120 volts = 120.)

| Voltage (Power)  | Electrical Characteristics  | Miscellaneous  |
|--|---|--|
| 24V50, 110V50, 230V50, 240V50 (6W)<br>24V60, 120V60, 240V60, 480V60 (6W)<br>6VDC, 12VDC, 24VDC, 48VDC, 125VDC (7W) | Class F epoxy molded coil (155°C).<br>Continuous duty. 3 leads 24" (61 cm). | Steel cover with 1/2 NPT conduit entry.<br>DIN style coil & connector: (-HC) |

| Voltage (Power)  | Electrical Characteristics   | Miscellaneous  |
|--|--|--|
| 24V50, 110V50, 230V50, 240V50 (5.6W)<br>24V60, 120V60, 240V60, 480V60 (5.6W)<br>6VDC, 12VDC, 24VDC, 48VDC, 125VDC (7.2W) | Class F epoxy molded coil (155°C)<br>Continuous duty.<br>3 leads 24" (60 cm).                | Steel chromate coated coil housing<br>with 1/2 NPT conduit entry.<br>For stainless steel (182 FM) coil housing add: (-ST.)   |
| 12V60, 24V60, 48V60, 120V60, 240V60 (1.8W)<br>6VDC, 12VDC, 24VDC, 48VDC (1.8W)   | Class F epoxy molded coil (155°C)<br>Continuous duty.<br>3 leads 24" (60 cm).                | Steel chromate coated coil housing with 1/2 NPT<br>conduit entry. For stainless steel (182 FM) coil<br>housing add: (-ST.) Maximum pilot pressure 120 psi<br>(8 bar). 1.8W nominal power.  |
| 24V50, 110V50, 230V50, 240V50 (5.6W)<br>24V60, 120V60, 240V60, 480V60 (5.6W)<br>6VDC, 12VDC, 24VDC, 48VDC, 125VDC (7.2W) | Class F epoxy molded coil (155°C)<br>Continuous duty.<br>3 leads 24" (60 cm).                | Steel chromate coated coil housing with M20 x 1.5<br>conduit entry. Ground terminal on cover.<br>For stainless steel (182 FM) coil housing add: (-ST.)   |
| 12V60, 24V60, 48V60, 120V60, 240V60 (1.8W)<br>6VDC, 12VDC, 24VDC, 48VDC (1.8W)   | Class F epoxy molded coil (155°C)<br>Continuous duty.<br>3 leads 24" (60 cm).                | Steel chromate coated coil housing with M20 x 1.5<br>conduit entry. Ground terminal on cover.<br>For stainless steel (182 FM) coil housing add: (-ST.)<br>Maximum pilot pressure 120 psi (8bar).<br>1.8W nominal power   |
| 24V50, 230V50 (6W); 127V50 (10W)<br>24V60, 120V60, 240V60 (10W)<br>12VDC, 24VDC, 28VDC, 48VDC, 110VDC, 125VDC (10W)      | Class F epoxy molded coil (155°C)<br>Continuous duty.  | Stainless Steel coil housing with internal Junction<br>Box. Internal and external ground screw.<br>M20 x 1.5 conduit entry: (-XDAS)<br>1/2 NPT conduit entry: (-XDAT)  |
| 24VDC (4W)<br>(Consult factory for other<br>voltage options)   | Continuous duty. Coil & Rectifier,<br>including surge suppression,<br>potted within housing. | Thick wall epoxy coil housing with integral<br>junction box. Internal ground terminal.<br>M20 x 1.5 conduit entry: (-XMAA)<br>Cable gland for 6-12 mm ø cable: (-XMAE)<br>1/2 NPT conduit entry with adapter: (-XMAF)<br>Cable gland for 9-16 mm ø cable: (-XMAG)                      |
| 24VDC (10W inrush, 2.6W holding)<br>(Consult factory for other<br>voltages)  | Continuous duty. Coil & power controller<br>potted within housing.                           | Thick wall epoxy coil housing with integral junction<br>box. Internal ground terminal.<br>M20 x 1.5 conduit entry: (-XMFA)<br>Cable gland for 6-12 mm ø cable: (-XMFE)<br>1/2 NPT conduit entry with adapter: (-XMFF)<br>Cable gland for 9-16 mm ø cable: (-XMFG)                      |
| 24VDC<br>system voltage prior to barrier<br>(1.6 watt max.)  | Class F epoxy molded coil (155°C)<br>Continuous duty.  | Requires the use of an approved barrier or isolator.<br>Maximum operating system voltage before barrier<br>28VDC.<br>Maximum pilot pressure 115 psi (8 bar)<br>3 spade terminals & DIN connector with PG9<br>cable gland; (-HC)<br>1/2 NPT conduit entry: (-HCC)                       |
| 24VDC<br>system voltage prior to barrier<br>(1.6 watt max.)  | Class F epoxy molded coil (155°C)<br>Continuous duty.  | Requires the use of an approved barrier or isolator.<br>Maximum operating system voltage before barrier<br>28VDC<br>Maximum pilot pressure 115 psi (8 bar)<br>3 spade terminals & DIN connector with PG9<br>cable gland: (-HC)<br>1/2 NPT conduit entry: (-HCC)                        |
| 24VDC (0.8W)<br>(Consult factory for other<br>voltages)  | Continuous duty..<br>Coil and power controller potted.<br>within housing.                    | Requires the use of an approved safety<br>barrier or isolator.<br>Thick wall epoxy coil housing and integral<br>junction box. Internal ground terminal.<br>M20 x 1.5 conduit entry: (-XIFA)<br>Cable gland for 6-12 mm ø cable: (-XIFE)<br>1/2 NPT conduit entry with adapter: (-XIFF) |



# SERIES B316 VALVES

STAINLESS STEEL CONSTRUCTION

## Solenoid/Pilot Operated Valves

A low power solenoid controls a built-in pilot which provides the positive force for shifting the valve spool. When used with a spring return the valve will be actuated when the solenoid is energized and will return when the solenoid is de-energized. When used in pairs for 2-position valves, the solenoid need only be energized momentarily in order to shift the valve. The valve will then remain in the shifted position until signalled to return by the opposite solenoid.

**INPilot** — utilizes the pressure from the inlet of the valve,

through internal passages, to the solenoid-pilot. In this type valve, only one pressure connection, the inlet, is necessary.

**EXPilot** — requires a separate auxiliary pressure line to the solenoid-pilot. Should be used when valve is controlling vacuum, when pressure will be below the minimum recommended for INPILOT operation or when viscosity of controlled medium is such that it will impede the speed of actuation. In any case, the pressure source may be either air or liquid and is independent of the medium which is being controlled by the valve.

### Valves For Nonhazardous Locations - 3/2 (Three-Way) Valves

Dimensions:  $\frac{\text{Inch}}{\text{mm}}$

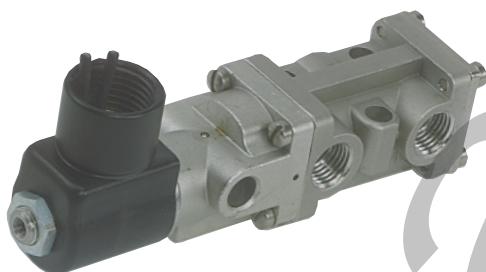

Solenoid-pilot operated/  
Spring Return

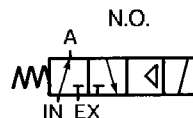
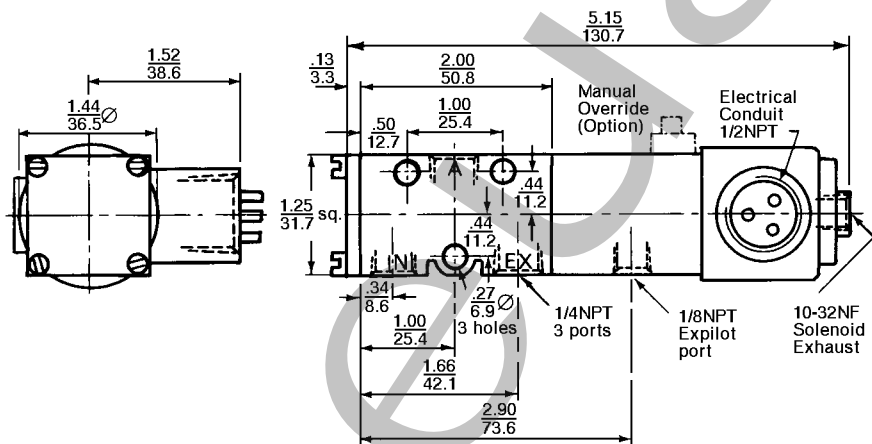

**EXPilot type**  
BSG-3306-316-(\*)

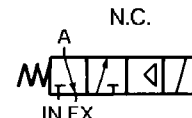

**EXPilot type**  
BSG-3308-316-(\*)

**INPilot type**  
BSG-3326-316-(\*)

**INPilot type**  
BSG-3328-316-(\*)

(\* ) Specify Options (page 11) & coil code (page 9).

**Single Solenoid Valves EXPilot**

| Controlled (inlet) Pressure                   |       |     |     |     |     |     |     |     |     |     |     |     |      |     |     |     |     |     |     |
|---|-------|-----|-----|-----|-----|-----|-----|-----|-----|-----|-----|-----|------|-----|-----|-----|-----|-----|-----|
| psi   | bar   | psi | bar | psi | bar | psi | bar | psi | bar | psi | bar | psi | bar  | psi | bar | psi | bar | psi | bar |
| 0-20  | 0-1.5 | 40  | 3   | 60  | 4.1 | 80  | 5.5 | 100 | 6.8 | 120 | 8.2 | 140 | 10   | 160 | 11  | 175 | 12  | 200 | 14  |
| <b>Auxiliary Min. pilot pressure required</b> |       |     |     |     |     |     |     |     |     |     |     |     |      |     |     |     |     |     |     |
| 18  | 1.25  | 20  | 1.4 | 22  | 1.5 | 24  | 1.7 | 26  | 1.8 | 28  | 2.0 | 30  | 2.15 | 32  | 2.3 | 34  | 2.4 | 36  | 2.5 |

**Single Solenoid Valves INPilot**

| Controlled (Inlet) Pressure              |            |
|--|------------|
| psi                                      | bar        |
| 18-175                                   | 1.25 to 12 |
| <b>Auxiliary pilot pressure required</b> |            |
| None                                     | None       |

Dimensions:  $\frac{\text{Inch}}{\text{mm}}$

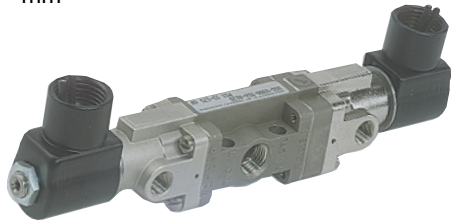

Solenoid-pilot operated/  
Solenoid-pilot return; (detented)

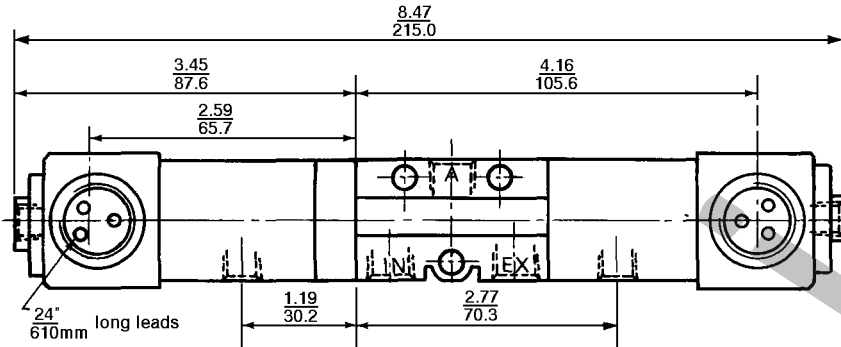

EXPilot type  
BGG-3308-316-(\* )

INPilot type  
BGG-3328-316-(\* )

(\* ) Specify Options (below) & coil code (page 9).

| Solenoid-pilot operated<br>Solenoid-Pilot return<br>(detented) | Controlled (Inlet) Pressure |      |         |      |
|--|-----------------------------|------|---------|------|
|  | EXPilot                     |      | INPilot |      |
|  | psi                         | bar  | psi     | bar  |
|  | 0-200                       | 0-14 | 15-175  | 1-12 |
| Auxiliary pilot<br>Pressure required                           | 15-175                      | 1-12 | none    | none |

Suffix Option:

**-3** CONTINUOUS DUTY SOLENOID and/or HIGH AMBIENT OR MEDIA TEMPERATURE: Recommended when coil may be energized for long periods and/or when ambient or media temperature will exceed 120°F (50°C). Standard on all solenoids for hazardous locations.

**-HT** CLASS H COIL: Recommended for applications above 150°F (65°C) and for DC continuous duty above 120°F (50°C). Not available with DIN style coil and connector.

**HC** DIN STYLE COIL & CONNECTOR: DIN type coil with 3 spade terminals and mini-DIN connector with PG9 cord grip. NEMA 4/IP65.

**-H2** THREADED SOLENOID-PILOT EXHAUST: Adapter attaches to solenoid to provide 1/8 NPT threaded port for piping of solenoid exhaust.

**-ME** MANUAL OVERRIDE: Manually pressurized pilot of solenoid-pilot actuator. Unguarded type-push and hold to operate. Use for set-up or when power to solenoid is absent.

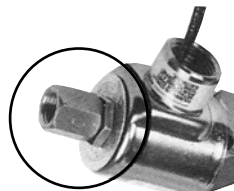

# SERIES B316 VALVES

STAINLESS STEEL CONSTRUCTION

## Valves For Hazardous Locations - 3/2 (Three-Way) Valves

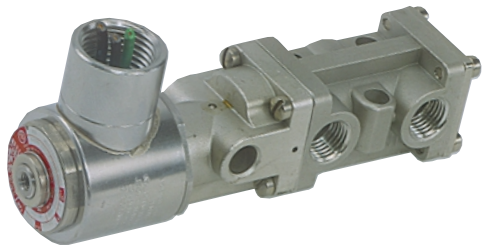

### HAZARDOUS LOCATIONS

Valves with -XX or -LB-XX type solenoids are UL listed and CSA approved.

### (d) FLAMEPROOF

Valves with -XN or -LB-XN type solenoids are ATEX certified.

See page 8/9 for additional solenoid details.

Dimensions:  $\frac{\text{Inch}}{\text{mm}}$

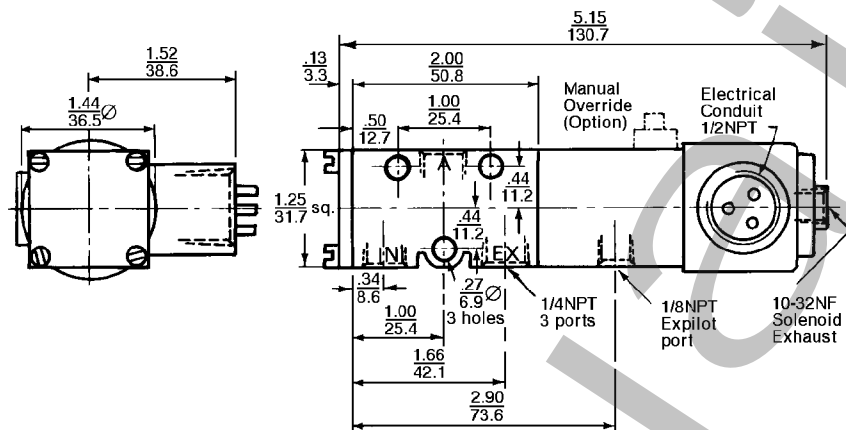

### Solenoid-pilot operated/ Spring return

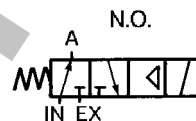

EXPilot type  
BSG-3306-316-†(\*)

INPilot type  
BSG-3326-316-†(\*)

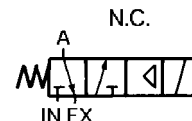

EXPilot type  
BSG-3308-316-†(\*)

INPilot type  
BSG-3328-316-†(\*)

### PRESSURES

Controlled (inlet) pressure & auxiliary pilot pressure (when required) are the same as those shown for the corresponding solenoid valve for non-hazardous locations, Pages 10 & 11.

### Solenoid-pilot operated/ Solenoid-pilot return; detented

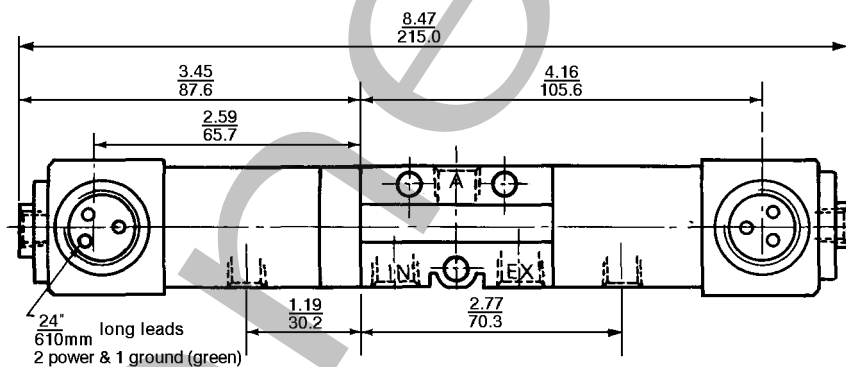

EXPilot type  
BGG-3308-316-†(\*)

INPilot type  
BGG-3328-316-†(\*)

### † Specify solenoid identification detail.

- LB-XN: (d) Flameproof; ATEX certified; low-watt; M20 x 1.5 conduit entry.
- LB-XX: Hazardous Locations; UL listed & CSA approved; low-watt, 1/2 NPT conduit entry.
- XN: (d) Flameproof; ATEX certified; M20 x 1.5 conduit entry.
- XX: Hazardous Locations; UL listed & CSA approved; 1/2 NPT conduit entry.

### (\*) Specify options (below) & coil code (page 9):

- H2: Threaded pilot exhaust adapter, 1/8 NPT
- ME: Manual override
- PC: Coil potted within housing
- ST: Stainless steel (182 FM) coil housing



**(d) FLAMEPROOF**

Valves with -XDAS or -XDAT type solenoids are ATEX certified.

See page 8/9 for additional solenoid details.

Dimensions:  $\frac{\text{Inch}}{\text{mm}}$

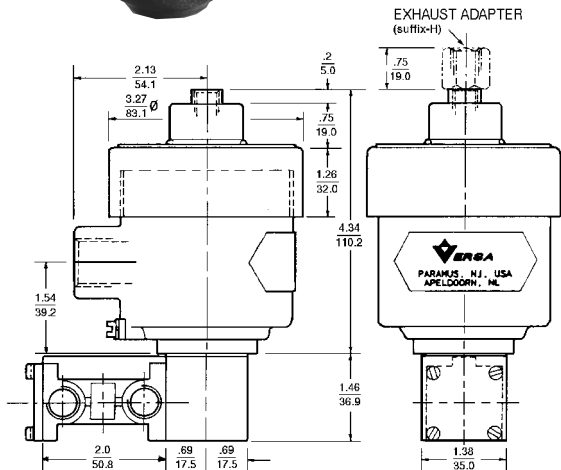

**Solenoid-pilot operated/ Spring Return**

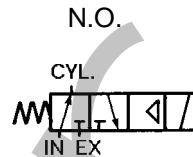

**EXPilot type**  
BSG-3306-316-XDA†(\*)

**INPilot type**  
BSG-3326-316-XDA†(\*)

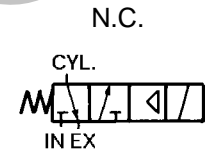

**EXPilot type**  
BSG-3308-316-XDA†(\*)

**INPilot type**  
BSG-3328-316-XDA†(\*)

**Solenoid-pilot operated/  
Solenoid-pilot return; detented (not shown)**



**EXPilot type:** BGG-3308-316-XDA†(\*)  
**INPilot type:** BGG-3328-316-XDA†(\*)

† Specify solenoid identification detail. S: M20 x 1.5 conduit entry  
T: 1/2 NPT conduit entry  
(\*) Specify options (at left) & coil code (page 9).

**PRESSURES**

Controlled (inlet) pressure & auxiliary pilot pressure (when required) are the same as those shown for the corresponding solenoid valve for nonhazardous locations, Pages 10 & 11.

**Suffix Options:**

- H2 Threaded solenoid-pilot exhaust adapter, with 1/8NPT thread
- H Threaded solenoid-pilot exhaust adapter, with 1/4NPT thread

**(m) ENCAPSULATION**

**(e) INCREASED SAFETY**

Valves with -XMA† or -XMF† type solenoids are ATEX certified.

See page 8/9 for additional solenoid details.

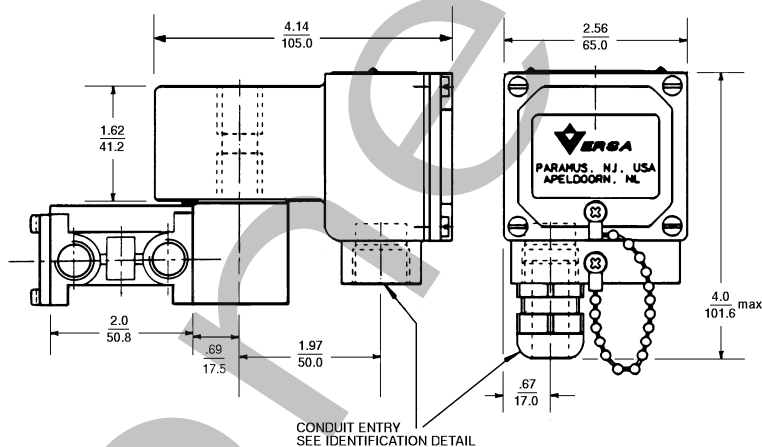

**Solenoid-pilot operated/ Spring return**



**EXPilot type:** BSG-3306-316-XMA†(\*)  
BSG-3306-316-XMF†(\*)

**INPilot type:** BSG-3326-316-XMA†(\*)  
BSG-3326-316-XMF†(\*)

†Specify solenoid identification detail.

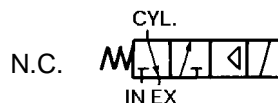

**EXPilot type:** BSG-3308-316-XMA†(\*)  
BSG-3308-316-XMF†(\*)

**INPilot type:** BSG-3328-316-XMA†(\*)  
BSG-3328-316-XMF†(\*)

A: M20 x 1.5 conduit entry;  
E: Cable gland for 6-12 mm ø cable;



TOP VIEW

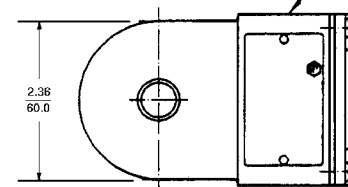

**PRESSURES**

Controlled (inlet) pressure & auxiliary pilot pressure (when required) are the same as those shown for the corresponding solenoid valve for nonhazardous locations, Pages 10 & 11.

**Solenoid-pilot operated/  
Solenoid-pilot return; detented (not shown)**

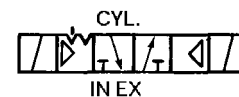

**EXPilot type:** BGG-3308-316-XMA†(\*)  
BGG-3308-316-XMF†(\*)

**INPilot type:** BGG-3328-316-XMA†(\*)  
BGG-3328-316-XMF†(\*)

F: 1/2 NPT conduit entry;  
G: Cable gland for 9-16 mm ø cable

(\*) Specify coil code (page 9).



# SERIES B316 VALVES

STAINLESS STEEL CONSTRUCTION

## Valves For Hazardous Locations - 3/2 (Three-Way) Valves

Dimensions:  $\frac{\text{Inch}}{\text{mm}}$



### HAZARDOUS LOCATIONS

Valves with -HC-XISC or HCC-XISC are CSA and Factory Mutual approved.

#### (ia) INTRINSIC SAFE

Valves with -HC-XISX6 or HCC-XISX6 are ATEX certified.

See page 8/9 for additional solenoid details.

#### PRESSURES

Controlled (inlet) pressure & auxiliary pilot pressure (when required) are the same as those shown for the corresponding solenoid valve for nonhazardous locations, Pages 10 & 11, EXCEPT maximum auxiliary pilot pressure for EXPilot valves & maximum controlled (inlet) pressure for INPilot valves is 115 psi (8 bar).

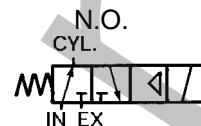
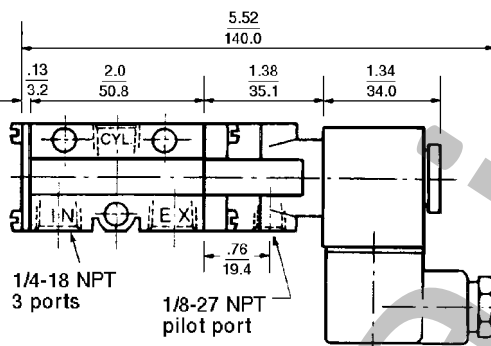

**EXPilot**  
BSG-3306-316-HC-XIS†-D024  
BSG-3306-316-HCC-XIS†-D024

**INPilot**  
BSG-3326-316-HC-XIS†-D024  
BSG-3326-316-HCC-XIS†-D024

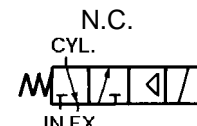

**EXPilot**  
BSG-3308-316-HC-XIS†-D024  
BSG-3308-316-HCC-XIS†-D024

**INPilot**  
BSG-3328-316-HC-XIS†-D024  
BSG-3328-316-HCC-XIS†-D024

#### Solenoid-pilot operated/ Solenoid-pilot return; detented



**EXPilot**  
BGG-3308-316-HC-XIS†-D024  
BGG-3308-316-HCC-XIS†-D024

**INPilot**  
BGG-3328-316-HC-XIS†-D024  
BGG-3328-316-HCC-XIS†-D024

† Specify solenoid identification detail. C or X6 (See page 8/9 for solenoid details).

#### (ib) INTRINSIC SAFE

Valves with -XIF† type solenoids are ATEX approved.

See page 8/9 for additional solenoid details.

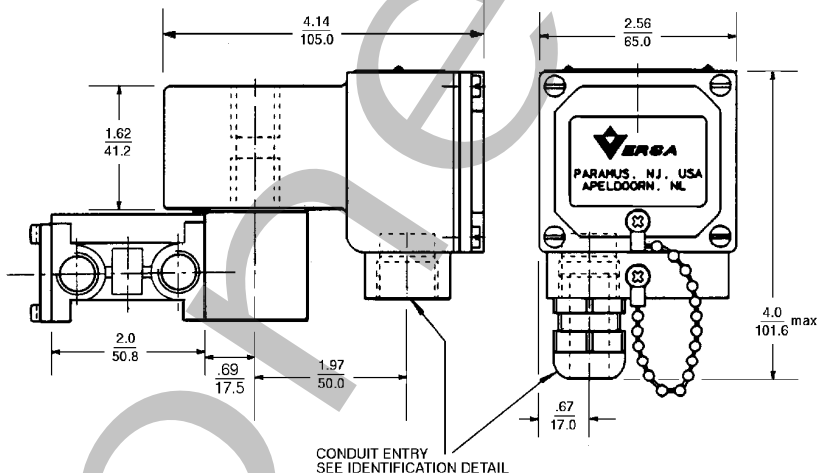

#### Solenoid-pilot operated/ Spring return

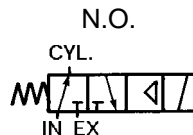

**EXPilot**  
BSG-3306-316-XIF†-(\*).

**INPilot**  
BSG-3326-316-XIF†-(\*).

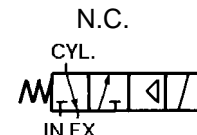

**EXPilot**  
BSG-3308-316-XIF†-(\*).

**INPilot**  
BSG-3328-316-XIF†-(\*).

#### Solenoid-pilot operated/ Solenoid-pilot return; detented (not shown)



**EXPilot** BGG-3308-316-XIF†-(\*)  
**INPilot** BGG-3328-316-XIF†-(\*).

#### PRESSURES

Controlled (inlet) pressure & auxiliary pilot pressure (when required) are the same as those shown for the corresponding solenoid valve for nonhazardous locations, Pages 10 & 11.

†Specify solenoid identification detail. A: M20 x 1.5 conduit entry; E: Cable gland for 6-12 mm ø cable; F: 1/2 NPT conduit entry.

(\*) Specify coil code (page 9).

# MANUAL SHUT-OFF VALVES



**STAINLESS STEEL CONSTRUCTION**

## General Description

Designed for use in emergency shut down systems, Manual Shut-Off valves are available in two types.

The Two-Way (2/2) valve is designated as a Block & Bleed valve. When the panel knob is pulled out, supply pressure is dumped to atmosphere.

The Three-Way (3/2) valve is designated as a Charge & Bleed valve. In the normal operating mode of this valve the inlet port

is connected to the outlet port and the exhaust port is blocked. When the panel knob is pulled out, supply pressure to the outlet port is blocked and the downstream pressure is dumped to atmosphere.

Any backpressure to the outlet port of either valve while functioning in the normal mode, will cause the valve to shift as if the panel knob were pulled out.

| OPERATING PRESSURE AND WEIGHT                   | Weight               | SYSTEM PRESSURE         | ALLOWABLE BACKPRESSURE at Outlet Port (Two-Way) or Exhaust Port (Three-Way) |
|---|----------------------|-------------------------|---|
| Two-Way (2/2)<br>Block & Bleed<br>MSO2-3-316    | 0.77 lbs.<br>(.35kg) | 0-150 psi<br>(0-10 bar) | 0   |
| Three-Way (3/2)<br>Charge & Bleed<br>MSO3-3-316 | 1.0 lbs.<br>(.45 kg) | 0-150 psi<br>(0-10 bar) | 0   |

## Materials

- Valve body and caps: 316 stainless steel (meets NACE Standard MR-01-75)
- Valve Seals: FKM (Fluorocarbon) O rings
- Screws: stainless steel
- Lid Knob: synthetic resin

## Porting Size and Flow

Inlet, outlet & exhaust ports: 1/4" NPT  
Internal orifice: 3/8" (9.5 mm)  $\varnothing$

## Installation

Valves have no limitations on mounting orientation. Valves can be panel mounted. Panel hole required: 1" (25.4 mm)  $\varnothing$

### TWO-WAY (2/2) BLOCK & BLEED

Product Number  
MSO2-3-316  
MSO2-3-316-125B

Button Color  
Red  
Black

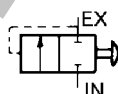
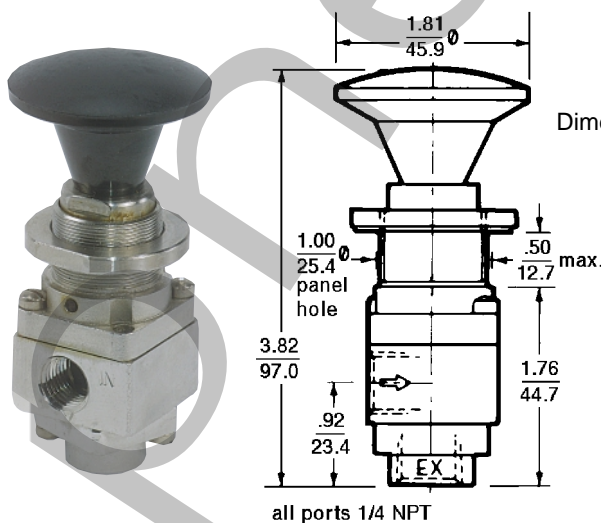

### THREE-WAY (3/2) CHARGE & BLEED

Product Number  
MSO3-3-316  
MSO3-3-316-125R

Button Color  
Black  
Red

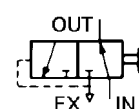
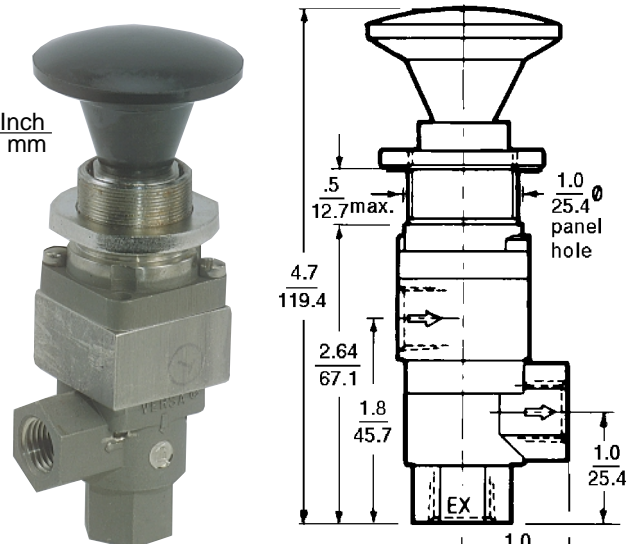

# Series B900 VALVES

STAINLESS STEEL CONSTRUCTION

## Main Supply Reset Valves

### General Description

Main Supply Reset Valves are Manual/Pilot operated, Spring Return, Three-Way (3/2), normally closed valves that are generally used to control and monitor the air pressure supply to an instrument control system. Monitoring is accomplished through the use of a monitor pilot, which is an integral part of the valve and which reacts to pressure signals from sensors within the system in order to shut down that specific portion of the system, should a malfunction occur.

The action of the valve for shut down and the method by which the control system pressure is restored differentiates the various Main Supply Reset valves available.

#### Knob Actuator —

The manual portion of the valve provides a lid knob which can be pulled out to actuate the valve, in order to start up or reset the control system pressure. A latch can be provided such that, once actuated, the valve can be manually latched in the actuated position. Unlatching might be accomplished by pulling on the knob or by applying pressure to the pilot.

An optional visual indicator, which is an integral part of the knob, can also be provided in order to indicate when pressure in the pilot chamber is actuating the valve.

All knob actuators are equipped for panel mounting utilizing a panel mounting nut which is included.

#### Air Pilot Actuator —

The air pilot portion of the valve is a small cylinder which is an integral part of the valve. The types available are:

**Air Pilot** - when pressurized will actuate the valve, and will unlatch the knob actuator if the latching feature is included.

**Air Latch Pilot** - when pressurized will not actuate the valve until knob is pulled out. Pressure in the pilot chamber can then hold the valve in the actuated position, and will unlatch the knob actuator if the latching feature is included.

### Construction

Versa B900 Valves are spool poppet valves. Standard size O ring seals, placed in accordance with Versa's Anti-Extrusion principle provides long trouble free service with little and easy maintenance.

### Materials

- Valve body and actuating caps: 316 stainless steel
- All internal wetted metal parts: 316 stainless steel or NACE approved materials
- Valve Seals: FKM (Fluorocarbon) O ring seals
- Screws: stainless steel

### Porting

- Valve ports are 1/4 NPT; Pilot ports are 1/8 NPT
- Flow area/C<sub>v</sub>; consult factory

### Pressure and Media

- 0 to 200 psig (14 bar); Air or Hydrocarbon gases or other gases compatible with materials used.
- Pressures for Pilot: see pages pertaining to specific valve.

### Temperature Range

Medium/Ambient temperature: -10°F (-23°C) to 200°F (95°C)

### Installation, Filtration & Lubrication

Valves have no limitations on mounting orientation. 40-50 micron filtration recommended. General purpose lubricating oil ISO, ASTM viscosity grade 32 recommended.

## MAIN SUPPLY RESET VALVES SELECTOR

| Knob Actuator |   |                |            | Pilot Actuator |  | Valve<br>Suffix     |
|---------------|---|----------------|------------|----------------|--|---------------------|
| Non-latching  | Manual Pin Latch  | Non-indicating | Indicating | Air Pilot      | Air Latch Pilot  |                     |
| X             |   | X              |            | X              |  | -159E<br>(page 17)  |
| X             |   | X              |            |                | X  | -301ES<br>(page 18) |
| X             |   |                | X          |                | X  | -900N<br>(page 18)  |
|               | X   | X              |            | X              |  | -900A<br>(page 17)  |
|               | X   | X              |            |                | X  | -900<br>(page 18)   |
|               | X   |                | X          | X              |  | -900P<br>(page 17)  |
|               | X   |                | X          |                | X  | -900W<br>(page 18)  |
|               | X<br>Manually resets valve plus, a built-in pilot (separate from Air Latch Pilot) enables valve to be reset from a remote location utilizing a pilot pressure signal. | X              |            |                | X  | -900PR<br>(page 19) |
|               | X   | X              |            |                | X<br>Functions same as Air Latch Pilot, but pilot signal is controlled by built-in solenoid. | -900G<br>(page 19)  |
| X             |   |                | X          |                | X  | -900NF<br>(page 19) |

Functions same as Air Latch Pilot plus, will trip if outlet port (which is connected to indicator valve loop) loses pressure, as in the case of a leak.

# Main Supply Reset Valves - 3/2 (Three-Way) Normally Closed Type: Air Pilot\*

These valves can be actuated (open to flow) by a pilot signal or manually by pulling the knob when there is no pilot signal. When the pilot signal is removed or drops below 7 psi (0.5 bar), or the knob is released when there is no pilot pressure, the valve will spring return to close the flow.

Valves provided with the manual pin latch feature can be latched in the actuated position (open to flow) when there is no pilot pressure, by pushing the manual latchpin and holding it in while the knob is pulled out and released. To release the

manual pin latch, pull the knob or apply a pilot signal.

Valves provided with a pressure indicator will appear **red** (black character "R" is also visible) when there is no pressure in the pilot chamber or the pilot pressure drops below 7 psi (0.5 bar), at which point the spring will return the valve to close the flow. The pressure indicator will appear **green** (black character "G" is also visible) when there is pilot pressure present in the pilot chamber.

Dimensions:  $\frac{\text{Inch}}{\text{mm}}$

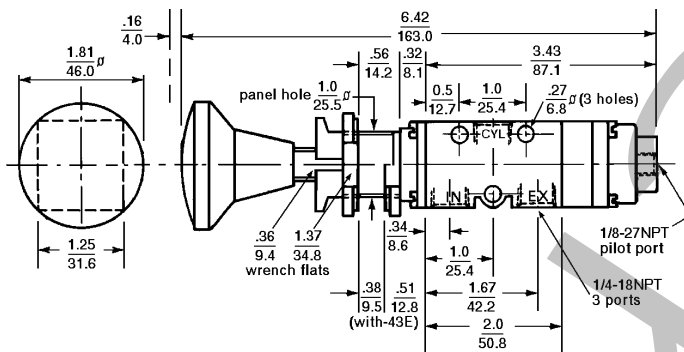

### Knob: Non-Latching, Non-Indicating

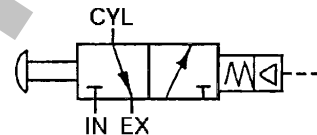

**BIA-3309-316-159E**

\* **Pilot signal required:** 25-200 psi (1.7-14 bar)  
When available pilot signal will not be less than 40 psi, Suffix Option -S is recommended.

**Maximum allowable exhaust backpressure:** 5 psi (0.3 bar)

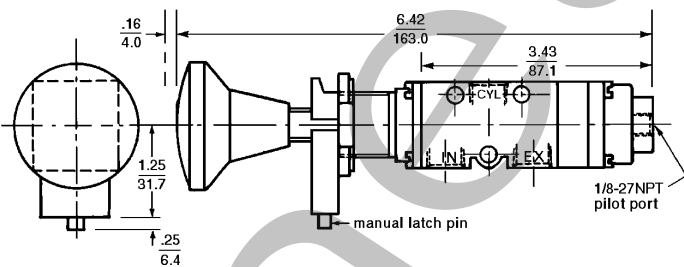

### Knob: Latching, Non-Indicating

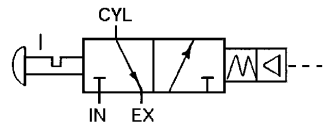

**BAA-3309-900A**

\* **Pilot signal required:** 25-200 psi (1.7-14 bar)  
When available pilot signal will not be less than 40 psi, Suffix Option -S is recommended.

**Maximum allowable exhaust backpressure:** 5 psi (0.3 bar)

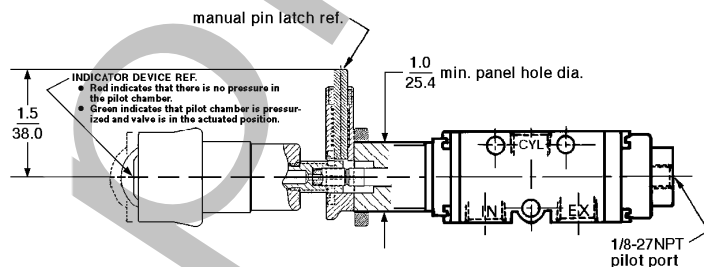

### Knob: Latching, Indicating

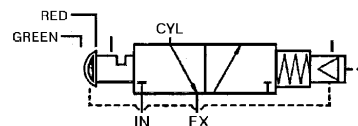

**BAA-3309-900P**

\* **Pilot signal required:** 25-200 psi (1.7-14 bar)  
When available pilot signal will not be less than 40 psi, Suffix Option -S is recommended.

**Maximum allowable exhaust backpressure:** 5 psi (0.3 bar)



# Series B900 VALVES

STAINLESS STEEL CONSTRUCTION

## Main Supply Reset Valves - 3/2 (Three-Way) Normally Closed Type: Air Latch Pilot\*

Pressure applied to the pilot latch port will not cause the pilot chamber to be pressurized until the knob is manually pulled out. Pilot pressure will then hold the valve open to flow against the spring. If the pilot pressure drops below 7 psi (0.5 bar) the spring will shift the valve to close the flow, and even if the pilot signal is restored, the valve will remain closed until the knob is manually pulled out.

Valves provided with the manual latch feature can be latched in the actuated position (open to flow) when there is no pilot pressure, by pushing the manual latchpin and holding it in

while the knob is pulled out and released. To release the manual latch, pull the knob or apply a pilot signal.

Valves provided with a pressure indicator will appear **red** (black character "R" is also visible) when the pilot chamber is not pressurized. The pilot chamber cannot be pressurized until the knob is pulled out at which point the indicator will appear **green** (black character "G" is also visible). If the pilot signal is then lost the spring will return the valve to close the flow and the indicator will appear **red** (R).

Dimensions: Inch  
mm

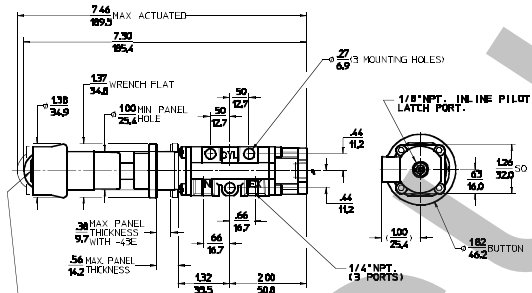
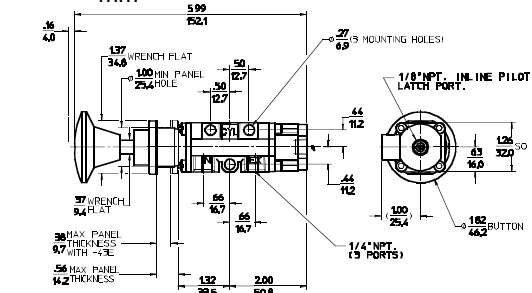

INDICATOR DEVICE REF  
 ● RED INDICATES THAT THERE IS NO PRESSURE IN THE PILOT LATCH CHAMBER.  
 ● GREEN INDICATES THAT THE PILOT CHAMBER IS PRESSURIZED AND THE VALVE IS IN THE ACTUATED POSITION.

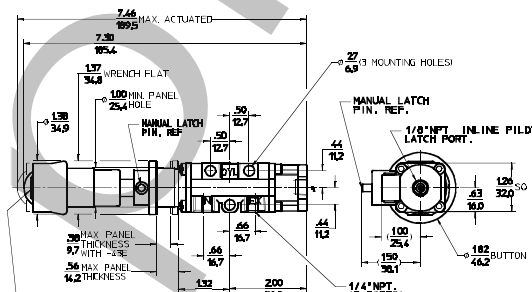
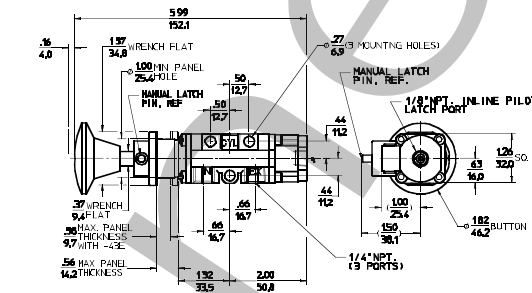

INDICATOR DEVICE REF  
 ● RED INDICATES THAT THERE IS NO PRESSURE IN THE PILOT LATCH CHAMBER.  
 ● GREEN INDICATES THAT THE PILOT CHAMBER IS PRESSURIZED AND THE VALVE IS IN THE ACTUATED POSITION.

### Knob: Non-Latching, Non-Indicating

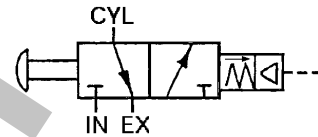

**BIA-3309-316-301ES**

\* Pilot signal required: 25-200 psi (1.7-14 bar)  
 When available pilot signal will not be less than 40 psi, Suffix Option -S is recommended.

Maximum allowable exhaust backpressure: 5 psi (0.3 bar)

### Knob: Non-Latching, Indicating

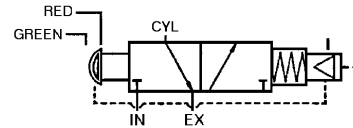

**BAA-3309-900N**

\* Pilot signal required: 25-200 psi (1.7-14 bar)  
 When available pilot signal will not be less than 40 psi, Suffix Option -S is recommended.

Maximum allowable exhaust backpressure: 5 psi (0.3 bar)

### Knob: Latching, Non-Indicating

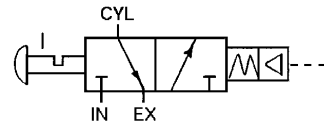

**BAA-3309-900**

\* Pilot signal required: 25-200 psi (1.7-14 bar)  
 When available pilot signal will not be less than 40 psi, Suffix Option -S is recommended.

Maximum allowable exhaust backpressure: 5 psi (0.3 bar)

### Knob: Latching, Indicating

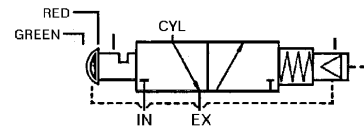

**BAA-3309-900W**

\* Pilot signal required: 25-200 psi (1.7-14 bar)  
 When available pilot signal will not be less than 40 psi, Suffix Option -S is recommended.

Maximum allowable exhaust backpressure: 5 psi (0.3 bar)

# Main Supply Reset Valves - 3/2 (Three-Way) Normally Closed

## Type: Specialized Application

Dimensions: Inch  
mm

**Description** Function is the same as Air Latch Pilot types on page 18 except that internal connection from CYL port to pilot provides the valve with a means to trip the valve closed to flow should a leak or other loss of pressure occur in the indicator loop line that connects "Indicator valves" to the pilot port. This feature eliminates need for separate connection from CYL port to "Indicator valves".

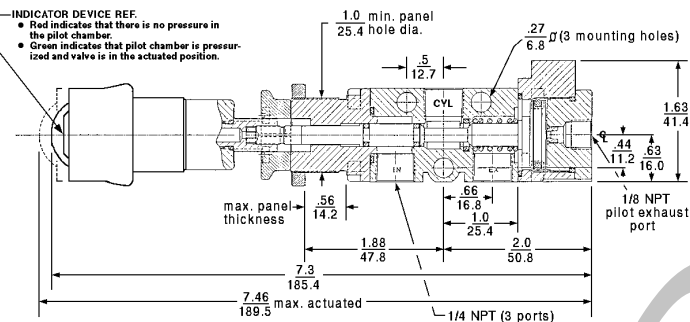

### Knob: Non-latching, Indicating

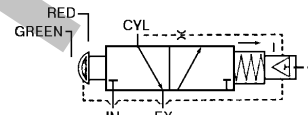

**BAA-3309-900NF**

**Controlled Pressure:** 0-75 psi (0-5.1 bar)  
**Pilot pressure required:** 25-75 psi (1.7-5.1 bar) to maintain air latch  
 When available pilot signal will not be less than 40 psi, Suffix Option -S is recommended.  
**Maximum allowable exhaust backpressure:** 5 psi (0.3 bar)

**Description** Function is the same as Air Latch Pilot types on page 18, but valve is additionally equipped with a Remote Pilot so that the valve can be reset with a remote pilot signal as well as manually. However, the manual pin latch is not activated by the remote pilot signal, so the valve will remain reset only as long as the remote pilot signal remains intact. Generally, this feature is useful where the Main Supply Reset valve is somewhat inaccessible and allows the operator to reset the valve from a separate location, until he is able to get to the station and activate the pin latch.

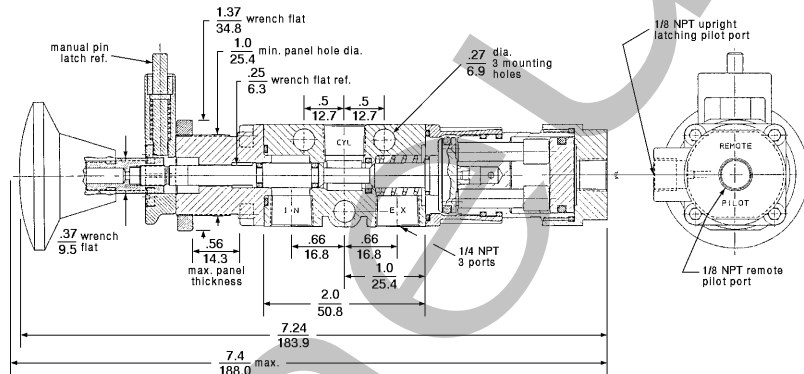

### Knob: Latching, Non-Indicating

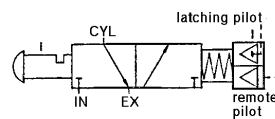

**BAA-3309-900PR**

**Controlled Pressure:** 0-200 psi (0-14 bar)  
**\* Pilot pressure required:** 50-200 psi (3.4-14 bar) to unlatch manual pin and to maintain air latch or actuate remotely  
**Maximum allowable exhaust backpressure:** 5 psi (0.3 bar)

**Description** Function is the same as Air Latch Pilot types on page 18, except Air Latch Pilot is solenoid controlled. Electrical signal causes pressure to be admitted to the pilot chamber from valve inlet through an internal passage to pilot, but Air Latch Pilot is not activated until knob is manually pulled out. The manual pin latch can be activated once the solenoid is de-energized.

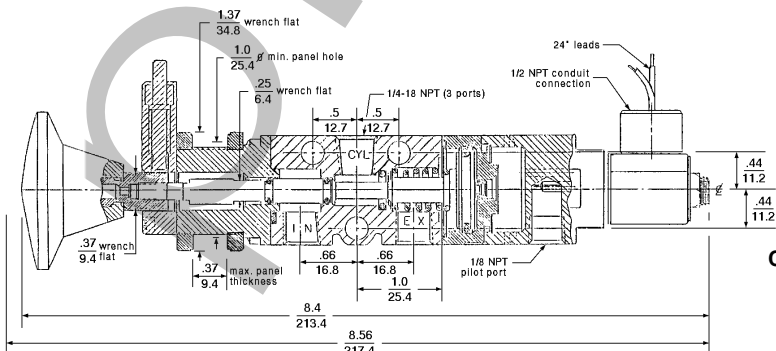

### Knob: Latching, Non-Indicating

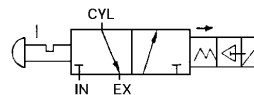

**BAA-3309-900G(\*)**

\*Specify coil code (Page 9).

**Controlled Pressure:** 25-120 psi (1.7-8.2 bar)  
 25 psi (1.7 bar) minimum to unlatch manual pin or to maintain air latch  
 When available inlet pressure will not be less than 40 psi, Suffix Option -S is recommended.  
**Maximum allowable exhaust backpressure:** 5 psi (0.3 bar)

# Series B900 & B550 VALVES

STAINLESS STEEL

HARDCOATED ALUMINUM

CONSTRUCTION

## Indicating Relay – Pilot Monitoring Valves

Indicating Relay valves are used to monitor the pilot actuators of the Main Supply Relay valves listed on pages 16-19. The Indicating Relays have two functions. First, to indicate visually on a panel that a circuit malfunction has occurred and secondly, to quickly cause operating pressure to exhaust from the system through the Main Supply Relay valve, allowing a valve operator or pneumatic system to shut-down. When placed in

series with other Indicating Relays, only the relay indicator of the relay controlling the circuit for which a malfunction is sensed will show **red** (R).

**Three types of Indicating Relays are available:**

- First Out Indicator-Transmitting type (page 20)
- First Out Indicator-Receiving type (page 21)
- First Out Indicator-Bypass type (page 22)

### FIRST OUT INDICATOR/INDICATING RELAY-TRANSMITTING TYPE

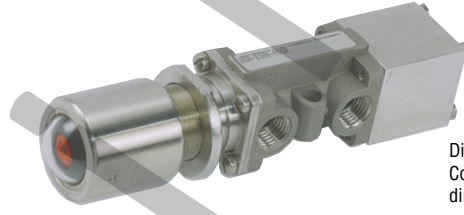
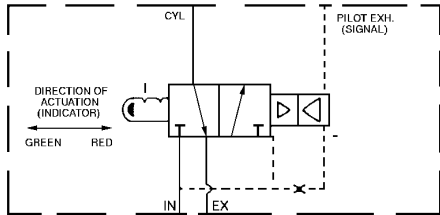

Dimensions are approximate. Consult factory for actual dimensions of specific valves.

| BAA-3308-900R  |   | BAA-3308-550R  |  |
|--|---|--|--|
| 316 stainless steel (NACE MR-01-75)                                    | <b>Construction:</b><br>Body, Internals, Caps   | Hardcoated Aluminum (MIL-A-8625E, Type III, Class1)                    |  |
| Stainless steel  | Fasteners-Seals-  | Stainless steel  |  |
| FKM (fluorocarbon) O rings   |   | FKM (fluorocarbon)   |  |
| 25-130 psi (1.7-8.8 bar)   | <b>Pressures:</b><br>Working (Controlled) pressure range-                             | 15-120 psi (1-8.2 bar)   |  |
| 5 psi (0.3 bar)  | Maximum allowable exhaust backpressure-   | 5 psi (0.3 bar)  |  |
| See Charts A & B below   | Pilot trip/reset-   | See Charts A & B below   |  |
| Consult Factory  | <b>Flow:</b>  | Consult Factory  |  |
| Air - 40 to 50 micron filtration recommended                           | <b>Media:</b>   | Air - 40 to 50 micron filtration recommended                           |  |
| 1/4" NPT<br>1/8" NPT   | <b>Porting:</b><br>Valve Ports-<br>Pilot Ports-                                       | 1/4" NPT<br>1/8" NPT   |  |
| Panel Mount (1" hole)  | <b>Mounting &amp; Installation:</b>   | Panel Mount (1" hole)  |  |
| <b>Red</b> (black character "R")<br><b>Green</b> (black character "G") | <b>Indicator colors:</b><br>Trip mode (depressurized)-<br>Working mode (pressurized)- | <b>Red</b> (black character "R")<br><b>Green</b> (black character "G") |  |
| (Consult factory for other color availability)                         |   |  |  |

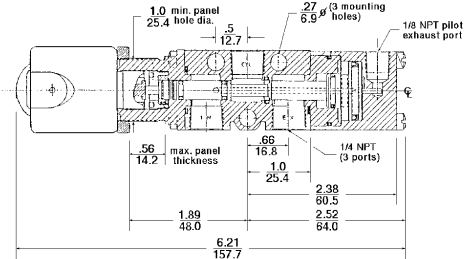
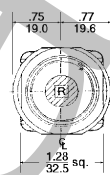

### Transmitting Relay Circuit (system in mode A - working range)

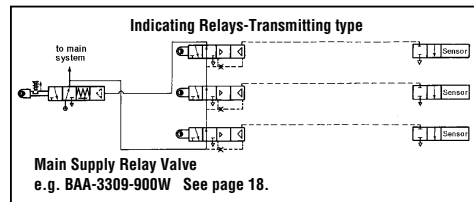

#### Operation Mode A

Flow path is open between the Relay inlet and "CYL" port whenever both the Relay inlet and pilot pressure are within the working pressure range in Chart A. In this condition the Relay indicator is **green** (G). If the Relay inlet pressure is lost while in this mode, the Relay flow position and indicator color will remain unchanged.

| Pressure Chart "A" (working range): Indicating Relay-Transmitting type |               |       |      |     |     |     |     |     |     |     |     |     |     |     |     |     |
|--|---------------|-------|------|-----|-----|-----|-----|-----|-----|-----|-----|-----|-----|-----|-----|-----|
| Indicating Relay Valve Inlet Pressure                                  | BAA-3308-900R | psig: | -    | -   | 25  | 30  | 40  | 50  | 60  | 70  | 80  | 90  | 100 | 110 | 120 | 130 |
|  | BAA-3308-550R | psig: | 15   | 20  | -   | 30  | 40  | 50  | 60  | 70  | 80  | 90  | 100 | 110 | 120 | -   |
| Minimum Reset-Pilot Pressure   | BAA-3308-900R | bar:  | -    | -   | 1.7 | 2.0 | 2.7 | 3.4 | 4.1 | 4.8 | 5.4 | 6.1 | 6.8 | 7.5 | 8.2 | 8.8 |
|  | BAA-3308-550R | bar:  | 1.0  | 1.4 | -   | 2.0 | 2.7 | 3.4 | 4.1 | 4.8 | 5.4 | 6.1 | 6.8 | 7.5 | 8.2 | -   |
| Maximum Trip Pilot Pressure  | BAA-3308-900R | psig: | -    | -   | 10  | 16  | 22  | 28  | 35  | 42  | 50  | 57  | 63  | 70  | 77  | 85  |
|  | BAA-3308-550R | psig: | 1    | 4   | -   | 10  | 15  | 21  | 26  | 32  | 37  | 44  | 47  | 53  | 59  | -   |
|  | BAA-3308-900R | bar:  | -    | -   | 0.7 | 1.1 | 1.5 | 1.9 | 2.4 | 2.9 | 3.4 | 3.9 | 4.3 | 4.8 | 5.2 | 5.8 |
|  | BAA-3308-550R | bar:  | 0.07 | 0.3 | -   | 0.7 | 1.0 | 1.4 | 1.8 | 2.2 | 2.5 | 3.0 | 3.2 | 3.6 | 4.0 | -   |

#### Operation Mode B

Flow path is open between the Relay "CYL" port and exhaust port whenever the Relay pilot chamber backpressure does not exceed the specifications in Chart B. In this condition the Relay indicator is **red** (R). The relay will automatically reset to operation mode A when both the Relay inlet and pilot pressure return to the working range, as indicated in Chart A.

| Pressure Chart "B" (shut-down range): Indicating Relay-Transmitting type |               |       |      |     |     |     |     |     |     |     |     |     |     |     |     |     |
|--|---------------|-------|------|-----|-----|-----|-----|-----|-----|-----|-----|-----|-----|-----|-----|-----|
| Indicating Relay Valve Inlet Pressure                                    | BAA-3308-900R | psig: | -    | -   | 25  | 30  | 40  | 50  | 60  | 70  | 80  | 90  | 100 | 110 | 120 | 130 |
|  | BAA-3308-550R | psig: | 15   | 20  | -   | 30  | 40  | 50  | 60  | 70  | 80  | 90  | 100 | 110 | 120 | -   |
| Maximum Trip Pilot Pressure  | BAA-3308-900R | bar:  | -    | -   | 1.7 | 2.0 | 2.7 | 3.4 | 4.1 | 4.8 | 5.4 | 6.1 | 6.8 | 7.5 | 8.2 | 8.8 |
|  | BAA-3308-550R | bar:  | 1.0  | 1.4 | -   | 2.0 | 2.7 | 3.4 | 4.1 | 4.8 | 5.4 | 6.1 | 6.8 | 7.5 | 8.2 | -   |
|  | BAA-3308-900R | psig: | -    | -   | 10  | 16  | 22  | 28  | 35  | 42  | 50  | 57  | 63  | 70  | 77  | 85  |
|  | BAA-3308-550R | psig: | 1    | 4   | -   | 10  | 15  | 21  | 26  | 32  | 37  | 44  | 47  | 53  | 59  | -   |
|  | BAA-3308-900R | bar:  | -    | -   | 0.7 | 1.1 | 1.5 | 1.9 | 2.4 | 2.9 | 3.4 | 3.9 | 4.3 | 4.8 | 5.2 | 5.8 |
|  | BAA-3308-550R | bar:  | 0.07 | 0.3 | -   | 0.7 | 1.0 | 1.4 | 1.8 | 2.2 | 2.5 | 3.0 | 3.2 | 3.6 | 4.0 | -   |

**FIRST OUT INDICATOR/INDICATING RELAY-RECEIVING TYPE**



Dimensions are approximate. Consult factory for actual dimensions of specific valves.

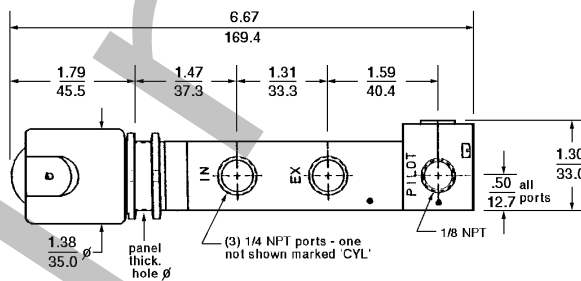
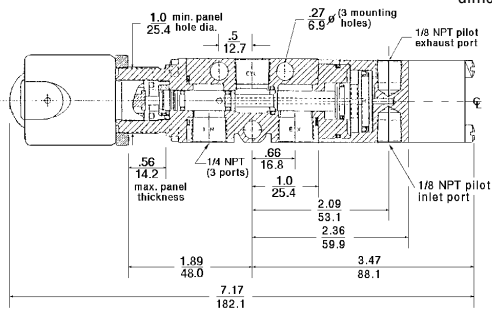
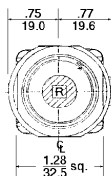
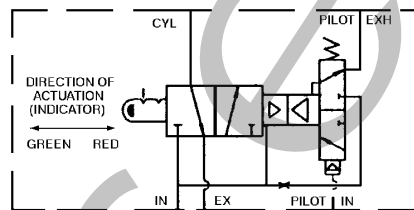

**BAA-3308-900RA**

**BAA-3308-550RA**

| 316 Stainless Steel (NACE MR-01-75)                                    | <b>Construction:</b><br>Body, Internals, Caps  | Hardcoated Aluminum (MIL-A-8625E, Type III, Class 1)  |                |                           |                          |          |         |         |          |          |         |          |          |          |          |          |          |          |          |          |           |          |          |           |          |          |
|--|--|---|----------------|---------------------------|--------------------------|----------|---------|---------|----------|----------|---------|----------|----------|----------|----------|----------|----------|----------|----------|----------|-----------|----------|----------|-----------|----------|----------|
| Stainless steel  | Fasteners  | Stainless steel   |                |                           |                          |          |         |         |          |          |         |          |          |          |          |          |          |          |          |          |           |          |          |           |          |          |
| FKM (ASTM D-1418) (ISO-1629)- (fluorocarbon) O rings                   | Seals  | FKM (fluorocarbon)  |                |                           |                          |          |         |         |          |          |         |          |          |          |          |          |          |          |          |          |           |          |          |           |          |          |
| 25-130 psi (1.7-8.8 bar)   | <b>Pressures:</b><br>Working (Controlled) Pressure Range   | 15-120 psi (1-8.2 bar)  |                |                           |                          |          |         |         |          |          |         |          |          |          |          |          |          |          |          |          |           |          |          |           |          |          |
| 5 psi (0.3 bar)  | Maximum allowable Exhaust Backpressure   | 5 psi (0.3 bar)   |                |                           |                          |          |         |         |          |          |         |          |          |          |          |          |          |          |          |          |           |          |          |           |          |          |
| 25-130 psi (1.7-8.8 bar)   | Pilot trip/reset   | <table border="1"> <thead> <tr> <th>Inlet Pressure</th> <th>Min. Reset Pilot Pressure</th> <th>Max. Trip Pilot Pressure</th> </tr> </thead> <tbody> <tr><td>15 (1.0)</td><td>9 (0.6)</td><td>3 (0.2)</td></tr> <tr><td>30 (2.0)</td><td>14 (1.0)</td><td>6 (0.4)</td></tr> <tr><td>50 (3.4)</td><td>23 (1.6)</td><td>12 (0.8)</td></tr> <tr><td>70 (4.8)</td><td>31 (2.1)</td><td>20 (1.4)</td></tr> <tr><td>90 (6.1)</td><td>38 (2.6)</td><td>27 (1.8)</td></tr> <tr><td>110 (7.5)</td><td>46 (3.1)</td><td>33 (2.2)</td></tr> <tr><td>120 (8.2)</td><td>50 (3.4)</td><td>37 (2.5)</td></tr> </tbody> </table> | Inlet Pressure | Min. Reset Pilot Pressure | Max. Trip Pilot Pressure | 15 (1.0) | 9 (0.6) | 3 (0.2) | 30 (2.0) | 14 (1.0) | 6 (0.4) | 50 (3.4) | 23 (1.6) | 12 (0.8) | 70 (4.8) | 31 (2.1) | 20 (1.4) | 90 (6.1) | 38 (2.6) | 27 (1.8) | 110 (7.5) | 46 (3.1) | 33 (2.2) | 120 (8.2) | 50 (3.4) | 37 (2.5) |
| Inlet Pressure   | Min. Reset Pilot Pressure  | Max. Trip Pilot Pressure  |                |                           |                          |          |         |         |          |          |         |          |          |          |          |          |          |          |          |          |           |          |          |           |          |          |
| 15 (1.0)   | 9 (0.6)  | 3 (0.2)   |                |                           |                          |          |         |         |          |          |         |          |          |          |          |          |          |          |          |          |           |          |          |           |          |          |
| 30 (2.0)   | 14 (1.0)   | 6 (0.4)   |                |                           |                          |          |         |         |          |          |         |          |          |          |          |          |          |          |          |          |           |          |          |           |          |          |
| 50 (3.4)   | 23 (1.6)   | 12 (0.8)  |                |                           |                          |          |         |         |          |          |         |          |          |          |          |          |          |          |          |          |           |          |          |           |          |          |
| 70 (4.8)   | 31 (2.1)   | 20 (1.4)  |                |                           |                          |          |         |         |          |          |         |          |          |          |          |          |          |          |          |          |           |          |          |           |          |          |
| 90 (6.1)   | 38 (2.6)   | 27 (1.8)  |                |                           |                          |          |         |         |          |          |         |          |          |          |          |          |          |          |          |          |           |          |          |           |          |          |
| 110 (7.5)  | 46 (3.1)   | 33 (2.2)  |                |                           |                          |          |         |         |          |          |         |          |          |          |          |          |          |          |          |          |           |          |          |           |          |          |
| 120 (8.2)  | 50 (3.4)   | 37 (2.5)  |                |                           |                          |          |         |         |          |          |         |          |          |          |          |          |          |          |          |          |           |          |          |           |          |          |
| Consult factory  | <b>Flow:</b> Controlled flow   | Consult factory   |                |                           |                          |          |         |         |          |          |         |          |          |          |          |          |          |          |          |          |           |          |          |           |          |          |
| Air  | <b>Media:</b> (40 to 50 micron filtration recommended)   | Air   |                |                           |                          |          |         |         |          |          |         |          |          |          |          |          |          |          |          |          |           |          |          |           |          |          |
| 1/4" NPT<br>1/8" NPT   | <b>Porting:</b> Valve Ports<br>Pilot Ports   | 1/4" NPT<br>1/8" NPT  |                |                           |                          |          |         |         |          |          |         |          |          |          |          |          |          |          |          |          |           |          |          |           |          |          |
| Panel mount (1" Ø hole)  | <b>Mounting &amp; Installation:</b>  | Panel mount (1" Ø hole)   |                |                           |                          |          |         |         |          |          |         |          |          |          |          |          |          |          |          |          |           |          |          |           |          |          |
| <b>Red</b> (black character "R")<br><b>Green</b> (black character "G") | <b>Indicator Colors:</b> Trip mode (depressurized)<br>Working mode (pressurized)<br>(Consult factory for other color availability) | <b>Red</b> (black character "R")<br><b>Green</b> (black character "G")  |                |                           |                          |          |         |         |          |          |         |          |          |          |          |          |          |          |          |          |           |          |          |           |          |          |

**Operation Mode A**

Flow path is open between the Relay inlet and "CYL" port whenever the pilot pressure from the process monitor and the Relay inlet pressure is in the working pressure range. In this condition the Relay indicator is **green (G)**. If the loss of inlet pressure occurs while in this mode, the relay flow position and indicator color will remain unchanged.

**Operation Mode B**

Upon loss of the pilot signal or decrease to the minimum trip pressure, the Relay will shift to block the inlet and to open the exhaust to the "CYL" port. In this condition the indicator shows **red (R)**. The Relay will not reset to **green (G)** until both sufficient pilot and inlet pressure are restored into the Relay.

**Receiving Relay Circuit**  
(system in mode A - working range)

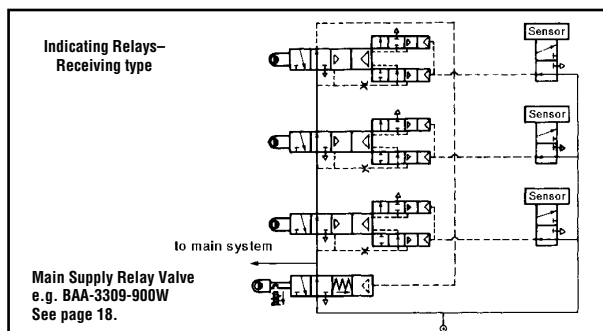



# Series B900 & B550 VALVES

ORDER  
ONLINE

STAINLESS STEEL

HARDCOATED ALUMINUM

CONSTRUCTION

## Indicating Relay – Pilot Monitoring Valves

### FIRST OUT INDICATOR/INDICATING RELAY-RECEIVING TYPE WITH INTEGRAL BYPASS

The First Out Indicator with an integral bypass combines the functions of two valves into one. Its primary function is that of the First Out Indicator/Indicating Relay-Receiving type (BAA-3308-550RA or BAA-3308-900RA) as shown on page 21. Additionally, an integral bypass valve enables specific circuits to be bypassed in the event of a malfunction, without shut-

down of the entire system. The additional piping, fittings and labor usually required to accomplish this feature are thus eliminated through the use of the Bypass type Indicating Relay valve. The bypass is accomplished by manually rotating (90°) a detented lever as part of the valve.

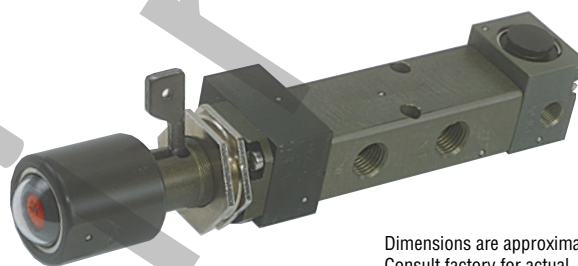
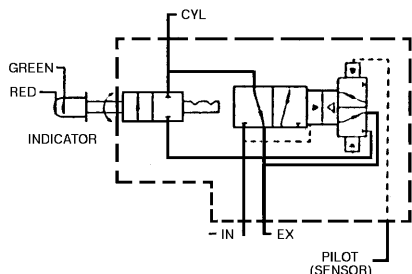

Dimensions are approximate. Consult factory for actual dimensions of specific valves.

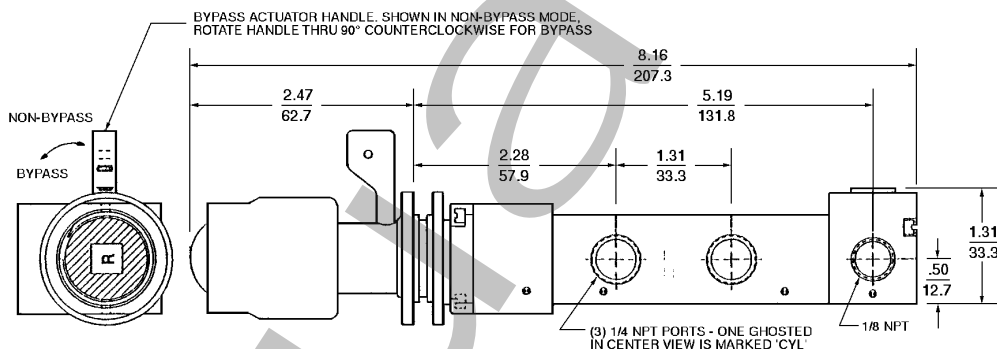

### BAA-3308-550AB

| <b>Construction:</b>                          |  |                           |                          |                           |                          |          |         |         |          |          |         |          |          |          |          |          |          |          |          |          |           |          |          |           |          |          |
|---|--|---------------------------|--------------------------|---------------------------|--------------------------|----------|---------|---------|----------|----------|---------|----------|----------|----------|----------|----------|----------|----------|----------|----------|-----------|----------|----------|-----------|----------|----------|
| Body, Internals, Caps -                       | Hardcoated Aluminum (MIL-A-8625E, Type III, Class 1)   |                           |                          |                           |                          |          |         |         |          |          |         |          |          |          |          |          |          |          |          |          |           |          |          |           |          |          |
| Seals -                                       | FKM (fluorocarbon)   |                           |                          |                           |                          |          |         |         |          |          |         |          |          |          |          |          |          |          |          |          |           |          |          |           |          |          |
| Fasteners & Bypass lever -                    | stainless steel  |                           |                          |                           |                          |          |         |         |          |          |         |          |          |          |          |          |          |          |          |          |           |          |          |           |          |          |
| <b>Pressures:</b>                             |  |                           |                          |                           |                          |          |         |         |          |          |         |          |          |          |          |          |          |          |          |          |           |          |          |           |          |          |
| Working (Controlled) pressure range -         | 15-120 psi (1-8.2 bar)   |                           |                          |                           |                          |          |         |         |          |          |         |          |          |          |          |          |          |          |          |          |           |          |          |           |          |          |
| Maximum allowable exhaust backpressure -      | 5 psi (0.3 bar)  |                           |                          |                           |                          |          |         |         |          |          |         |          |          |          |          |          |          |          |          |          |           |          |          |           |          |          |
| Pilot trip/reset -                            | <table border="1"> <thead> <tr> <th>psi (bar)</th> <th>Inlet Pressure</th> <th>Min. Reset Pilot Pressure</th> <th>Max. Trip Pilot Pressure</th> </tr> </thead> <tbody> <tr> <td>15 (1.0)</td> <td>9 (0.6)</td> <td>3 (0.2)</td> </tr> <tr> <td>30 (2.0)</td> <td>14 (1.0)</td> <td>6 (0.4)</td> </tr> <tr> <td>50 (3.4)</td> <td>23 (1.6)</td> <td>12 (0.8)</td> </tr> <tr> <td>70 (4.8)</td> <td>31 (2.1)</td> <td>20 (1.4)</td> </tr> <tr> <td>90 (6.1)</td> <td>38 (2.6)</td> <td>27 (1.8)</td> </tr> <tr> <td>110 (7.5)</td> <td>46 (3.1)</td> <td>33 (2.2)</td> </tr> <tr> <td>120 (8.2)</td> <td>50 (3.4)</td> <td>37 (2.5)</td> </tr> </tbody> </table> | psi (bar)                 | Inlet Pressure           | Min. Reset Pilot Pressure | Max. Trip Pilot Pressure | 15 (1.0) | 9 (0.6) | 3 (0.2) | 30 (2.0) | 14 (1.0) | 6 (0.4) | 50 (3.4) | 23 (1.6) | 12 (0.8) | 70 (4.8) | 31 (2.1) | 20 (1.4) | 90 (6.1) | 38 (2.6) | 27 (1.8) | 110 (7.5) | 46 (3.1) | 33 (2.2) | 120 (8.2) | 50 (3.4) | 37 (2.5) |
| psi (bar)                                     | Inlet Pressure   | Min. Reset Pilot Pressure | Max. Trip Pilot Pressure |                           |                          |          |         |         |          |          |         |          |          |          |          |          |          |          |          |          |           |          |          |           |          |          |
| 15 (1.0)                                      | 9 (0.6)  | 3 (0.2)                   |                          |                           |                          |          |         |         |          |          |         |          |          |          |          |          |          |          |          |          |           |          |          |           |          |          |
| 30 (2.0)                                      | 14 (1.0)   | 6 (0.4)                   |                          |                           |                          |          |         |         |          |          |         |          |          |          |          |          |          |          |          |          |           |          |          |           |          |          |
| 50 (3.4)                                      | 23 (1.6)   | 12 (0.8)                  |                          |                           |                          |          |         |         |          |          |         |          |          |          |          |          |          |          |          |          |           |          |          |           |          |          |
| 70 (4.8)                                      | 31 (2.1)   | 20 (1.4)                  |                          |                           |                          |          |         |         |          |          |         |          |          |          |          |          |          |          |          |          |           |          |          |           |          |          |
| 90 (6.1)                                      | 38 (2.6)   | 27 (1.8)                  |                          |                           |                          |          |         |         |          |          |         |          |          |          |          |          |          |          |          |          |           |          |          |           |          |          |
| 110 (7.5)                                     | 46 (3.1)   | 33 (2.2)                  |                          |                           |                          |          |         |         |          |          |         |          |          |          |          |          |          |          |          |          |           |          |          |           |          |          |
| 120 (8.2)                                     | 50 (3.4)   | 37 (2.5)                  |                          |                           |                          |          |         |         |          |          |         |          |          |          |          |          |          |          |          |          |           |          |          |           |          |          |
| <b>Flow:</b>                                  | Consult factory  |                           |                          |                           |                          |          |         |         |          |          |         |          |          |          |          |          |          |          |          |          |           |          |          |           |          |          |
| <b>Media:</b>                                 | Air<br>40 to 50 micron filtration recommended  |                           |                          |                           |                          |          |         |         |          |          |         |          |          |          |          |          |          |          |          |          |           |          |          |           |          |          |
| <b>Porting:</b>                               | Valve ports - 1/4" NPT<br>Pilot ports - 1/8" NPT   |                           |                          |                           |                          |          |         |         |          |          |         |          |          |          |          |          |          |          |          |          |           |          |          |           |          |          |
| <b>Mounting &amp; Installation:</b>           | Panel mount (1" ø hole)  |                           |                          |                           |                          |          |         |         |          |          |         |          |          |          |          |          |          |          |          |          |           |          |          |           |          |          |
| <b>Indicator Colors:</b>                      | Trip mode (depressurized) - <b>Red</b> (black character "R")<br>Working mode (pressurized) - <b>Green</b> (black character "G")  |                           |                          |                           |                          |          |         |         |          |          |         |          |          |          |          |          |          |          |          |          |           |          |          |           |          |          |
| Consult factory for other color availability. |  |                           |                          |                           |                          |          |         |         |          |          |         |          |          |          |          |          |          |          |          |          |           |          |          |           |          |          |



## Repair Kits & Information

VERSA Valves are designed and built to provide millions of troublefree cycles. However, in the event that a valve should require repair, most likely due to wear or some kind of abuse, in most cases the valve can be restored to “new” condition by the replacement of the valve seals. Kits containing the necessary items are available and are listed below, for specific valve types.

**CAUTION:** Before attempting to repair any VERSA Valve, always be certain that all pressure in the system including the valve to be repaired, has been turned off and the system and valve has been depressurized before proceeding with the repair. Serious injury or death may occur if this procedure is neglected.

| <b>SERIES B316<br/>VALVES</b>   | <b>Valve<br/>Product Number</b>               | <b>Repair<br/>Kit Number</b>  |
|---|---|---|
| ALL<br>Manual-<br>Cam-<br>Pilot-<br>Solenoid-<br>(nonhazardous &<br>hazardous location)<br>VALVES | BSI or BIA<br>BSC<br>BSP or BPP<br>BSG or BGG | *B-3308-316<br><br>*Additional nonhazardous<br>solenoid parts not included<br>in kit:<br><br>P-1005-08 Solenoid Plunger<br>P-1005-02-(Coil Code) Coil |

For valves with Suffix Option -EP add -EP to product number listed above.

| <b>MAIN SUPPLY<br/>RELAY VALVES</b> | <b>Valve<br/>Product Number</b>   | <b>Repair<br/>Kit Number</b>  |
|-------------------------------------|---|---|
| Air Pilot<br>type                   | BIA-3309-316-159E<br>BAA-3309-900A<br>BAA-3309-900P   | *B-3308-316   |
| Air Latch Pilot<br>type             | **BIA-3309-316-301ES<br>**BAA-3309-900<br>**BAA-3309-900N<br>**BAA-3309-900W<br><br>**BAA-3309-900NF<br>**BAA-3309-900PR<br>BAA-3309-900G | *B-3308-316-900<br><br>*Additional solenoid parts not<br>included in kit:<br><br>P-1005-08 Solenoid Plunger<br>P-1005-02-(Coil Code) Coil |

\*\*These valves are equipped with easy access pilot cap assemblies which can be removed with a crescent or open-end type wrench in order to remove the valve plunger assembly while the valve is still mounted in the panel.

For valves with Suffix Option -EP add -EP to product number listed above.

| <b>INDICATING RELAY<br/>VALVES</b> | <b>Valve<br/>Product Number</b> | <b>Repair<br/>Kit Number</b> |
|------------------------------------|---------------------------------|------------------------------|
| -900 type                          | BAA-3308-900R<br>BAA-3308-900RA | B-3308-316-900               |
| -550 type                          | BAA-3308-550R<br>BAA-3308-550RA | B-3308-550RA                 |
|                                    | BAA-3308-550RAB                 | B-3308-550RAB                |

For valves with Suffix Option -EP add -EP to product number listed above.